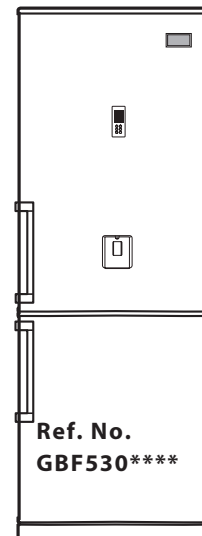
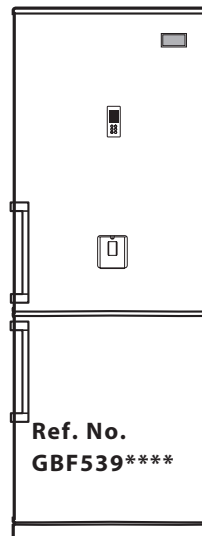
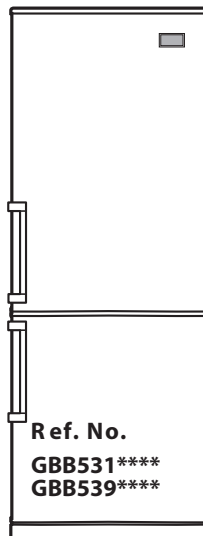
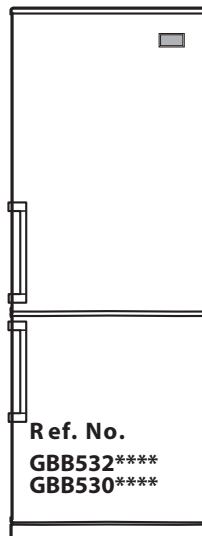

# REFRIGERATOR

# SERVICE MANUAL

**CAUTION**

BEFORE SERVICING THE UNIT, READ THE "SAFETY PRECAUTIONS" IN THIS MANUAL.

**MODEL :****COLOR :**

# CONTENTS

---

SAFETY PRECAUTIONS .....	2
SERVICING PRECAUTIONS .....	3
SPECIFICATIONS .....	4-7
PARTS IDENTIFICATION .....	8-12
INSTRUCTIONS FOR REVERSING DOOR SWING .....	13-15
DISASSEMBLY .....	16-17
DOOR .....	16
DOOR SWITCH .....	16
FAN AND FAN MOTOR .....	16
DEFROST CONTROL ASSEMBLY .....	17
FREEZER HEATER, SHEATH .....	17
ADJUSTMENT .....	18-19
COMPRESSOR (A++ and A+ Models) .....	18
PTC-STARTER (A++ and A+ Models) .....	18
OLP (OVER LOAD PROTECTOR) (A++ and A+Models) .....	19
COMPRESSOR .....	20-28
INVERTER LINEAR COMPRESSOR .....	20-28
HEAVY REPAIR METHOD OF REFRIGERATOR BY APPLICATION OF REFRIGERANT .....	29-34
OUTLINE .....	29
HEAVY REPAIR SVC METHOD .....	30-34
CIRCUIT DIAGRAM .....	35-4%
TROUBLESHOOTING (MECHANICAL PART) .....	4&-49
COMPRESSOR AND ELECTRIC COMPONENTS .....	4&
PTC AND OLP .....	4'
ANOTHER ELECTRIC COMPONENTS .....	4(
SERVICE DIAGNOSIS CHART .....	4)
REFRIGERATING CYCLE .....	4*-' "
MICOM FUNCTION & PCB CIRCUIT EXPLANATION .....	5#-5&
MICOM ERROR CODE .....	5' -5)
PCB PICTURE .....	5*-6&
TROUBLESHOOTING WITH ERROR DISPLAY .....	6' -7(
TROUBLESHOOTING WITHOUT ERROR DISPLAY .....	7) -8%
REFERENCE .....	8&-8*
EXPLODED VIEW &REPLACEMENT PARTS LIST .....	8+--+#

## SAFETY PRECAUTIONS

---

Please read the following instructions before servicing your refrigerator.

1. Check the set for electric losses.
2. Unplug prior to servicing to prevent electric shock.
3. Whenever testing with power on, wear rubber gloves to prevent electric shock.
4. If you use any kind of appliance, check regular current, voltage and capacity.
5. Don't touch metal products in the freezer with wet hands. This may cause frostbite.
6. Prevent water from following onto electric elements in the mechanical parts.
7. When standing up after having checked the lower section of the refrigerator with the upper door open, move with care to avoid hitting the upper door.
8. When tilting the set, remove any materials on the set, especially the thin plates(ex. Glass shelf or books.)
9. When servicing the evaporator, wear cotton gloves. This is to prevent injuries from the sharp evaporator fins.
10. Leave the disassembly of the refrigerating cycle to a specialized service center. The gas inside the circuit may pollute the environment.
11. When you discharge the refrigerant, wear the protective safety glasses or goggle for eye safety.
12. When you repair the cycle system in refrigerator, the work area is well ventilated. Especially if the refrigerant is R600a, there are no fire or heat sources. (No smoking)

# SERVICING PRECAUTIONS

## Features of refrigerant (R600a)

- Achromatic and odorless gas.
- Flammable gas and the ignition (explosion) at 494°C.
- Upper/lower explosion limit: 1.8%~8.4%/Vol.

## Features of the R600a refrigerator

- Charging of 60% refrigerant compared with a R134a model.
- The suction pressure is below 1bar (abs) during the operation.
- Because of its low suction pressure, the external air may flow in the cycle system when the refrigerant leak, and it causes malfunction in the compressor.
- The displacement of compressor using R600a must be at least 1.7 times larger than that of R134a.
- Any type of dryer is applicable (XH-5, 7, 9).
- The EVAPORATOR or any other cycle part that has welding joint is hidden in the foam. (If not hidden inside, the whole electric parts must be tested with the LEAKAGE TEST according to the IEC Standard.)
- The compressor has label of the refrigerant R600a.
- Only the SVC man must have an access to the system.

## Installation place

- Must be well ventilated.
- Must be 20 m<sup>3</sup> or larger.
- Must be no-smoking area.
- No ignitable factors must be present.

## Utilities

- Refrigerant cylinder (MAX NET 300g)
- Manometer
- Vacuum pump (600ℓ /min)
- Piercing Clamp
- Quick coupler
- Hoses (5m-1EA, 1m-3EA)
- LOKRING
- Portable Leakage detector (3g/year )
- Nitrogen cylinder (for leakage test)
- Concentration gauge

## Make sure before Servicing

- Refrigerant  
Confirm the refrigerant by checking Name Plate and the label on the compressor, after opening the COVER ASSEMBLY, BACK-M/C.
- If the refrigerant is R600a, you must not weld or apply a heat source.

## Air Recharging in Compressor

Before refilling the refrigerant, you must perform the test according to Chapter 5 (TROUBLESHOOTING CHART). When the defects are found, you must discharge the residual refrigerant (R600a) in the outdoor. For discharging the refrigerant R600a, break the narrow portion of tube extension by hand or with a pipe cutter as shown in Figure 1. Leave it for 30min in outside to stabilize the pressure with ambient. Then, check the pressure by piercing the dryer part with piercing pliers. If the refrigerant is not completely discharged, let the refrigerator alone for more 30min in outside.

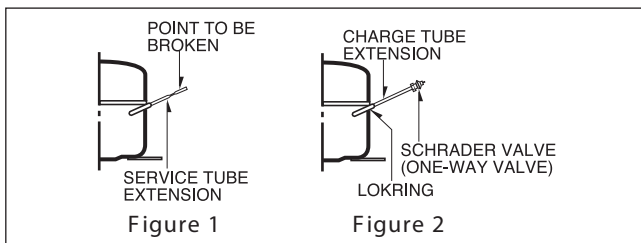

Attach the service tube installed with a Schrader valve (one-way valve) by using the LOKRING (Figure 2). Then, connect the Schrader valve (one-way valve) to the pump that is connected to the discharging hose leading to the outside. When discharging the residual refrigerant, repeat 3 cycle that includes 3min of the pump running->pump off->30sec of the compressor running.

After the refrigerant (R600a) is completely discharged, repair any defective parts and replace the dryer. At any case you must use the LOKRING for connecting or replacing any part in the cycle (No Fire, No Welding). Charge the N2 gas in order to check for leakage from welding points and the LOKRING. If leakages are found, repair the defects again. Connect the Schrader valve to pump with the coupler. And then turn the pump on for vacuum state (Figure 3). Let the pump run until the low pressure gauge indicates the vacuum (gauge pressure -1atm or -760mmHg, absolute pressure 0). Recommended vacuum time is 30 min.

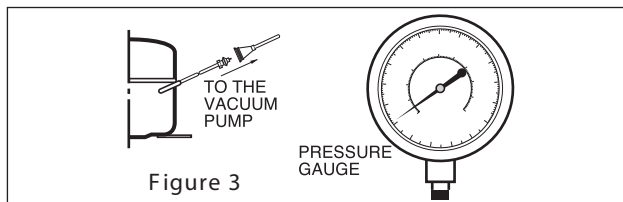

After the system is completely vacuumed, fill it with the refrigerant R600a up to what has been specified at your refrigerator Name Plate. The amount of refrigerant (R600a) must be precisely measured within the error of ±2g by an electron scale (Figure 4).

If you use the manifold connected with both the refrigerant (R600a) cylinder and the vacuum pump simultaneously, make sure the pump valve is closed (Figure 5).

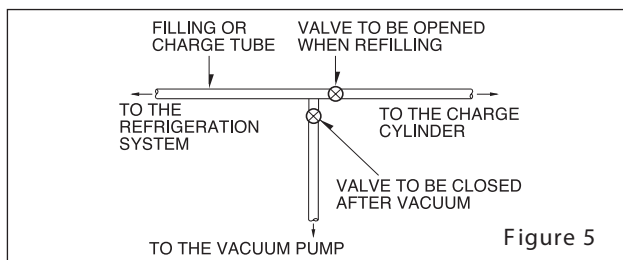
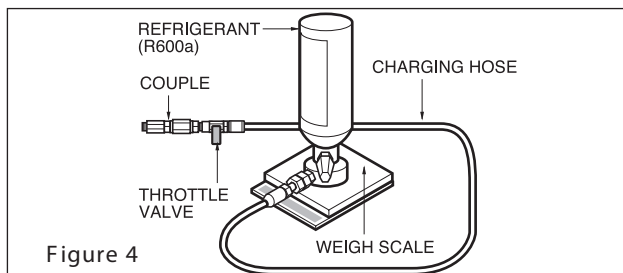

Connect the charging hose (that is connected to the refrigerant (R600a) cylinder) to the Schrader valve installed on the service tube. Then, charge the refrigerant (R600a) by controlling the Throttle valve. When you do so, do not fully open the Throttle valve because it may make damage to the compressor. Gradually charge the refrigerant (R600a) by changing open and close the Throttle Valve (5g at each time). The charging hose must use a one-way valve to prevent the refrigerant reflux. Close the Schrader valve cap after the refrigerant (R600a) is completely recharged.

After you completely recharge the refrigerant (R600a), perform the leakage test by using a portable leakage detector or soapy water. Test the low pressure (suction) parts in compressor off time and high pressure parts in compressor on time. If the leakages are found, restart from the refrigerant (R600a) discharging process and repairs defects of leaks.

After the leakage test, check the temperature of each parts of the cycle. Check with hands if the CONDENSER and the case (HOT-LINE pipe) that is contacted to the door gasket are warm. Confirm that frost is uniform distributed on the surface of the EVAPORATOR.

# SPECIFICATIONS

1. Ref. No: GBB530\*\*\*\*\*, GBF530\*\*\*\*\*, GBB530\*\*\*\*Q\*

ITEMS		GBB 530*** F*	GBB 530*** P*	GBB 530*** W*	GBF 530*** D*	GBB530***X*	GBB530***Z*	GB F530***Z*	GBB530***Q*
DIMENSIONS (mm)	595(W) X 2010(H) X 650(D)	●	●	●	●	●	●	●	●
	595(W) X 1900(H) X 650(D)	-	-	-	-	-	-	-	-
NET WEIGHT		-	-	-	-	-	-	-	-
COOLING SYSTEM	Fan Cooling	●	●	●	●	●	●	●	●
TEMPERATURE CONTROL	Micom Control	●	●	●	●	●	●	●	●
DEFROSTING SYSTEM	Full Automatic	●	●	●	●	●	●	●	●
	Heater Defrost	●	●	●	●	●	●	●	●
DEFROSTING DEVICE	Heater, S heath	●	●	●	●	●	●	●	●
REFRIGERANT WEIGHT	R600a	67g (FLB124) 65g (FMA102)	63g (CMA089) 67g (FLA102) 61g (BMG089)	57g (BMG089) 61g (CMA089)	63g (CMA089) 67g (FLA102) 61g (BMG089)	67g 67g	67g (FLA102) 61g (BMG089)	67g (FLA102) 61g (BMG089)	67g
LUBRICATION OIL	HTS55MT	-	180cc(FLA102)	-	180cc(FLA102)	-	180cc(FLA102)	180cc(FLA102)	-
	S5 HFP	175cc(FLB124) 120cc(FMA102)	150cc(CMA089) 170cc(BMG089)	170cc(BMG089)	150cc(CMA089) 170cc(BMG089)	175cc(FLB124)	170cc(BMG089)	170cc(BMG089)	175cc(FLB124)
COMPRESSOR	5HFP	-	-	150ccCMA089	-	-	-	-	-
EVAPORATOR	PTC Starting Type	-	Yes(CMA089) No (FLA102/BMG089)	●	●	-	-	-	-
CONDENSER	P in Tube Type	●	●	●	●	●	●	●	●
	Spiral Condenser	●	-	-	-	●	-	-	●
	Wire Condenser	-	●	●	●	-	-	-	-
REFRIGERATOR COMPARTMENT	Removable Glass Shelf	3EA(option 2)	3EA	3EA(option 2)	3EA	2EA	3EA	3EA	2EA
	Vita, LED(1EA)	-	-	-	-	-	-	-	-
	Cover, TV (L)	●	●	●	●	●	●	●	●
	Cover, TV (U)	●	●	●	●	●	●	●	●
	Fresh 0 Zone	●	●	●	●	●	●	●	●
	Magic Crisper (1EA)	●	●	●	●	●	●	●	●
	Vegetable Drawer (1EA)	●	●	●	●	●	●	●	●
	Folding Shelf	- (option ●)	-	-	-	●	-	-	●
	Bottle Rack	●	-	-	-	●	●	●	●
	Egg Tray	●	●	●	●	●	●	●	●
DOOR BASKET	Dairy Corner	●	●	- (option ●)	●	●	●	●	●
	Basket	3EA	3EA	4EA	3EA	3EA	3EA	3EA	3EA
	Water Tank	-	-	-	●	-	-	●	-
	Tray Drawer (3EA)	●	●	●	●	●	●	●	●
FREEZER COMPARTMENT	Tray Ice	●	●	●	●	●	●	●	●
	Ice Box	-	-	-	-	-	-	-	-
	Wire Shelf (2EA)	●	●	●	●	●	●	●	●

# SPECIFICATIONS

## 1. Ref. No: GBB539\*\*\*\*, GBF539\*\*\*\*

ITEMS		GBB539***F*	GBB539***P*	GBB539***W*	GBF 539***W*	GBB539***F*	GBB539***Z*
DIMENSIONS (mm)	595(W) X 2010(H) X 650(D)	-	-	-	-	-	-
	595(W) X 1900(H) X 650(D)	●	●	●	●	●	●
NET WEIGHT		-	-	-	-	-	-
COOLING SYSTEM	Fan Cooling	●	●	●	●	●	●
TEMPERATURE CONTROL	Micom Control	●	●	●	●	●	●
DEFROSTING SYSTEM	Full Automatic	●	●	●	●	●	●
	Heater Defrost	●	●	●	●	●	●
DEFROSTING DEVICE	Heater, Sheath	●	●	●	●	●	●
REFRIGERANT WEIGHT	R600a	67g (FLB124) 65g (FMA102)	63g (CMA089) 67g (FLA102) 61g (BMG089)	57g (BMG089) 61g (CMA089)	57g (BMG089) 61g (CMA089)	67g (FLB124) 65g (FMA102)	67g (FLA102) 61g (BMG089)
LUBRICATION OIL	HTS55 MT	-	180cc(FLA102)	-	-	-	180cc(FLA102)
	S5 HFP	175cc(FLB124) 120cc(FMA102)	150cc(CMA089) 170cc(BMG089) 170cc(BMG089)	170cc(BMG089)	170cc(BMG089)	175cc(FLB124) 120cc(FMA102)	170cc(BMG089)
	5HFP	-	-	150ccCMA089	150ccCMA089	-	-
COMPRESSOR	PTC Starting Type	-	Yes(CMA089) No (FLA102/BMG089)	●	●	-	-
EVAPORATOR	Pin Tube Type	●	●	●	●	●	●
CONDENSER	Spiral Condenser	●	-	-	-	●	-
	Wire Condenser	-	●	●	●	-	●
	Removable Glass Shelf	2EA (option 1)	2EA	2EA (option 1)	2EA (option 1)	2EA(option 1)	2EA (option 1)
REFRIGERATOR COMPARTMENT	Vita, LED(1EA)	-	-	-	-	-	-
	Cover, TV (L)	●	●	●	●	●	●
	Cover, TV (U)	●	●	-	-	●	● (option -)
	Fresh 0 Zone	●	●	-	-	●	● (option -)
	Magic Crisper (1EA)	●	●	-	-	●	● (option -)
	Vegetable Drawer (1EA)	●	●	●	●	●	●
	Folding Shelf	- (option ●)	-	-	-	- (option ●)	-
	Bottle Rack	●	-	-	-	●	- (option ●)
	Egg Tray	●	●	●	●	●	●
	Dairy Corner	●	●	- (option ●)	- (option ●)	●	●
Basket	2EA	2EA	3EA	3EA	2EA	2EA	
Water Tank	-	-	-	●	-	-	
Tray Drawer (3EA)	●	●	●	●	●	●	
Tray Ice	●	●	●	●	●	●	
Ice Box	-	-	-	-	-	-	
Wire Shelf (2EA)	●	●	●	●	●	●	

# SPECIFICATIONS

1. Ref. No: GBB539\*\*\*\*\*, GBF539\*\*\*\*\*

ITEMS		GB B539**HW*	GB B 539**HP*	GBB539**HZ*
DIMENSIONS (mm)	595(W) X 2010(H) X 650(D)	-	-	-
	595(W) X 1900(H) X 650(D)	⊙	⊙	⊙
NET WEIGHT		-	-	-
COOLING SYSTEM	Fan Cooling	⊙	⊙	⊙
TEMPERATURE CONTROL	Micom Control	⊙	⊙	⊙
DEFROSTING SYSTEM	Full Automatic	⊙	⊙	⊙
	Heater Defrost	⊙	⊙	⊙
DEFROSTING DEVICE	Heater, S heath	⊙	⊙	⊙
REFRIGERANT WEIGHT	R 600a	57g (BMG089) 61g (CMA089)	63g	67g
LUBRICATION OIL	5HFP	170cc(BMG089)	-	-
	S5 HFP	150cc(CMA089)	⊙	⊙
COMPRESSOR	PTC Starting Type	⊙	⊙	⊙
EVAPORATOR	Pin Tube Type	⊙	⊙	⊙
CONDENSER	Spiral Condenser	-	-	-
	Wire Condenser	⊙	⊙	⊙
REFRIGERATOR COMPARTMENT	Removable Glass Shelf	3EA	3EA	3EA
	Vita, LED(1EA)	-	-	-
	Cover, TV (L)	⊙	⊙	⊙
	Cover, TV (U)	-	-	-
	Fresh 0 Zone	-	-	-
	Magic Crisper (1EA)	-	-	-
	Vegetable Drawer (1EA)	⊙	⊙	⊙
DOOR BASKET	Egg Tray	⊙	⊙	⊙
	Dairy Corner	-	-	-
	Basket	3EA	3EA	3EA
	Water Tank	-	-	-
FREEZER COMPARTMENT	Tray Drawer (3EA)	⊙	⊙	⊙
	Tray Ice	⊙	⊙	⊙
	Ice Box	-	-	-
	Wire Shelf (2EA)	-	-	-

# SPECIFICATIONS

1. Ref. No: GBB530\*\*\*M\*, GBF539\*\*\*M\*

ITEMS		GBB530**QM*	GBB539**QM*
DIMENSIONS (mm)	595(W) X 2010(H) X 650(D)	⊙	-
	595(W) X 1900(H) X 650(D)	-	⊙
NET WEIGHT		-	-
COOLING SYSTEM	Fan Cooling	⊙	⊙
TEMPERATURE CONTROL	Micom Control	⊙	⊙
DEFROSTING SYSTEM	Full Automatic	⊙	⊙
	Heater Defrost	⊙	⊙
DEFROSTING DEVICE	Heater, S heath	⊙	⊙
REFRIGERANT WEIGHT	R 600a	61g	61g
LUBRICATION OIL	HTS55MT	-	-
	S5 HFP (5CST)	170cc	170cc
COMPRESSOR	PTC Starting Type	⊙	⊙
EVAPORATOR	Pin Tube Type	⊙	⊙
CONDENSER	Spiral Condenser	-	-
	Wire Condenser	⊙	⊙
REFRIGERATOR COMPARTMENT	Removable Glass Shelf	3EA	2EA
	Vita, LED(1EA)	-	-
	Cover, TV (L)	⊙	⊙
	Cover, TV (U)	⊙	⊙
	Fresh 0 Zone	⊙	⊙
	Magic Crisper (1EA)	⊙	⊙
	Vegetable Drawer (1EA)	⊙	⊙
	Folding Shelf	-	-
DOOR BASKET	Bottel Rack	⊙	⊙
	Egg Tray	⊙	⊙
	Dairy Corner	⊙	⊙
	Basket	3EA	2EA
FREEZER COMPARTMENT	Water Tank	-	-
	Tray Drawer (3EA)	⊙	⊙
	Tray Ice	⊙	⊙
	Ice Box	-	-
	Wire Shelf (2EA)	⊙	⊙

# PARTS IDENTIFICATION

GBB530\*\*\*\*

Model Name : GBB530\*\*Q\*\*, GBB530\*\*C\*\*

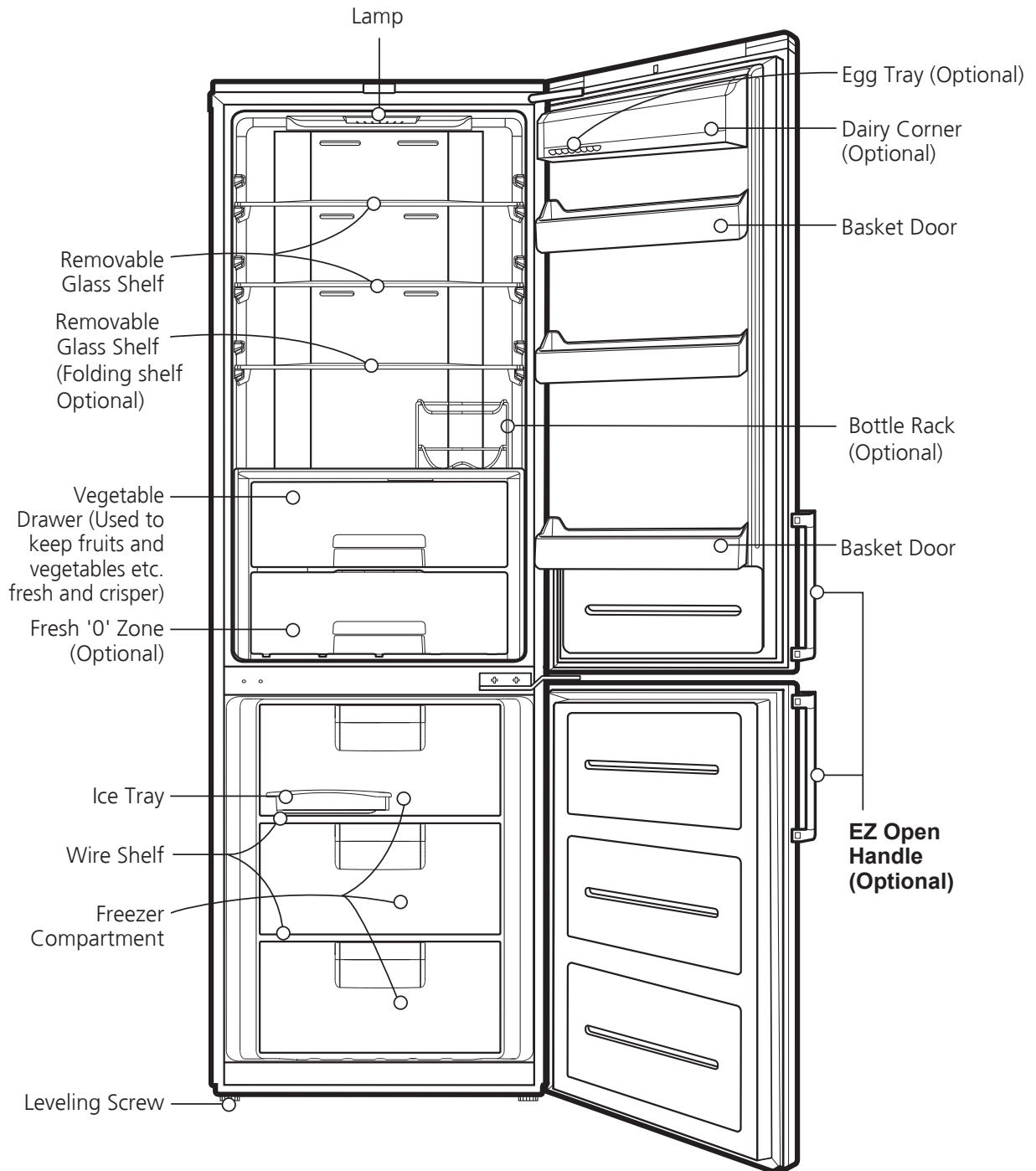



# PARTS IDENTIFICATION

GBB530\*\*\*\*\*

Model Name : GBF530\*\*Q\*\*

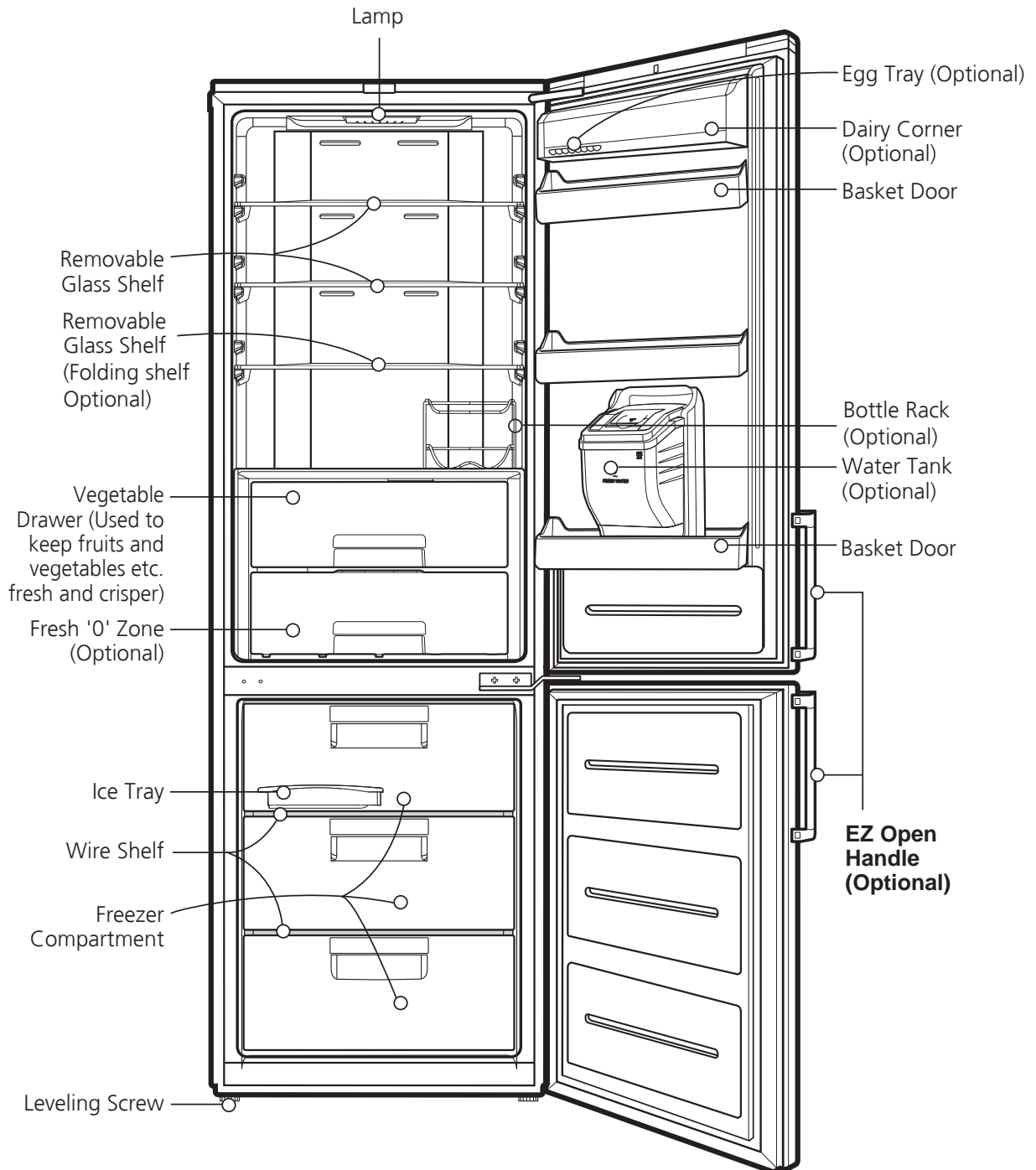

# PARTS IDENTIFICATION

GBB539\*\*\*\*\*

Model Name : GBB539\*\*QF\*, GBB539\*\*QP\*, GBB539\*\*CF\*, GBB539\*\*CP\*, GBB539\*\*CZ\*, GBB539\*\*QZ\*

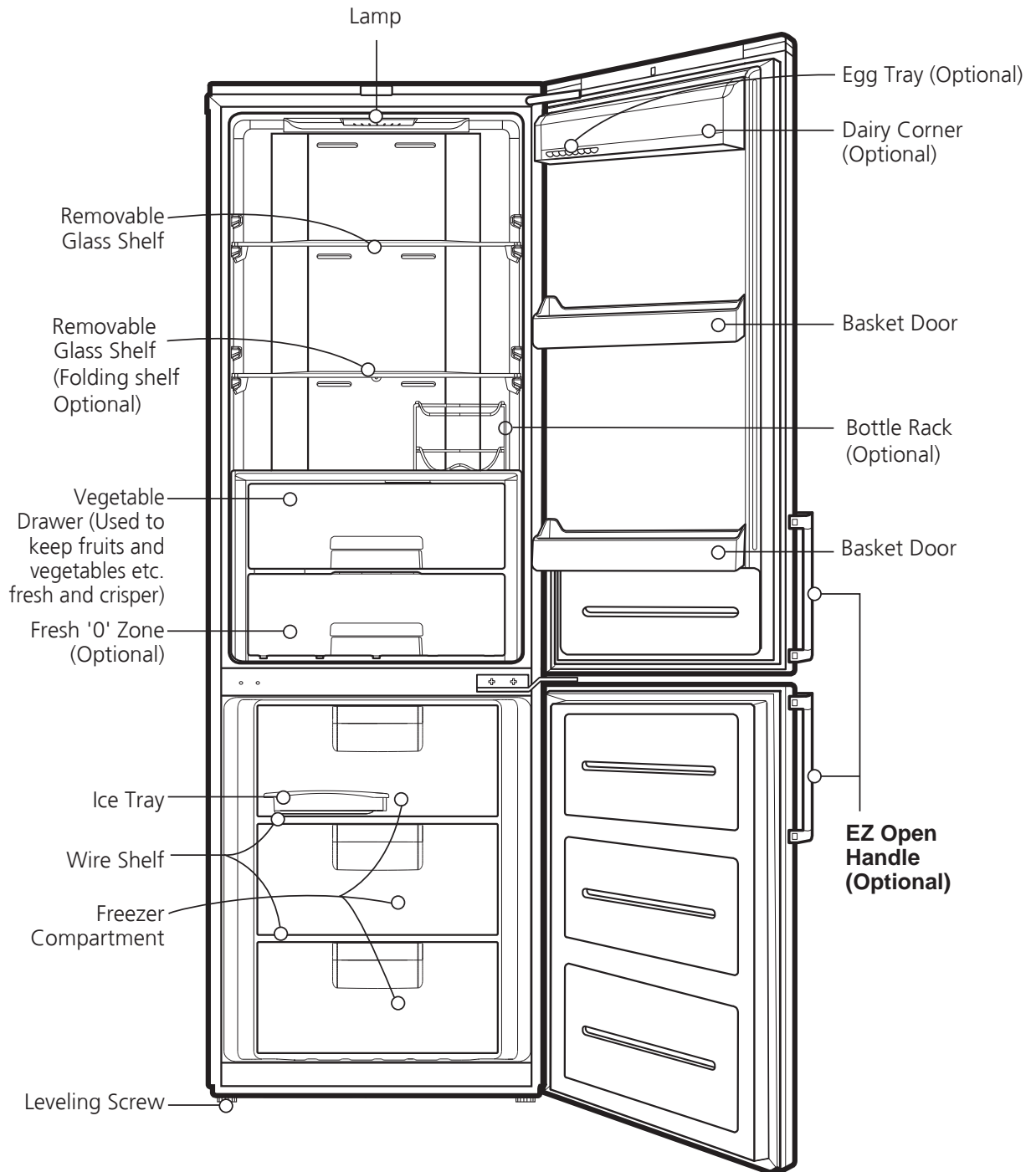

# PARTS IDENTIFICATION

GBB539\*\*\*\*

Model Name : GBB539\*\*QW\*, GBB539\*\*HW\*

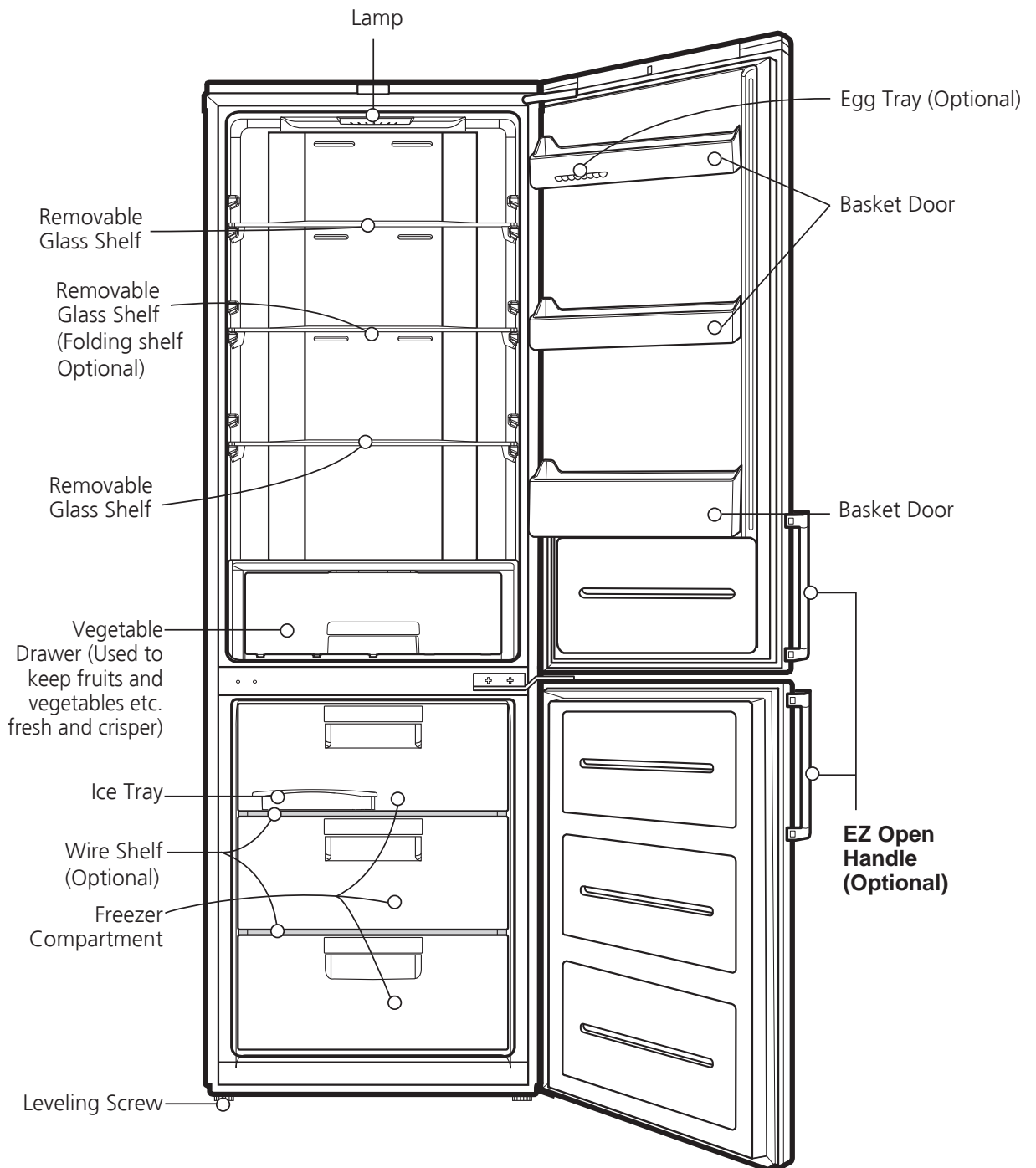

# PARTS IDENTIFICATION

GB B539\*\*\*\*

Model Name : GBF539\*\*\*W\*

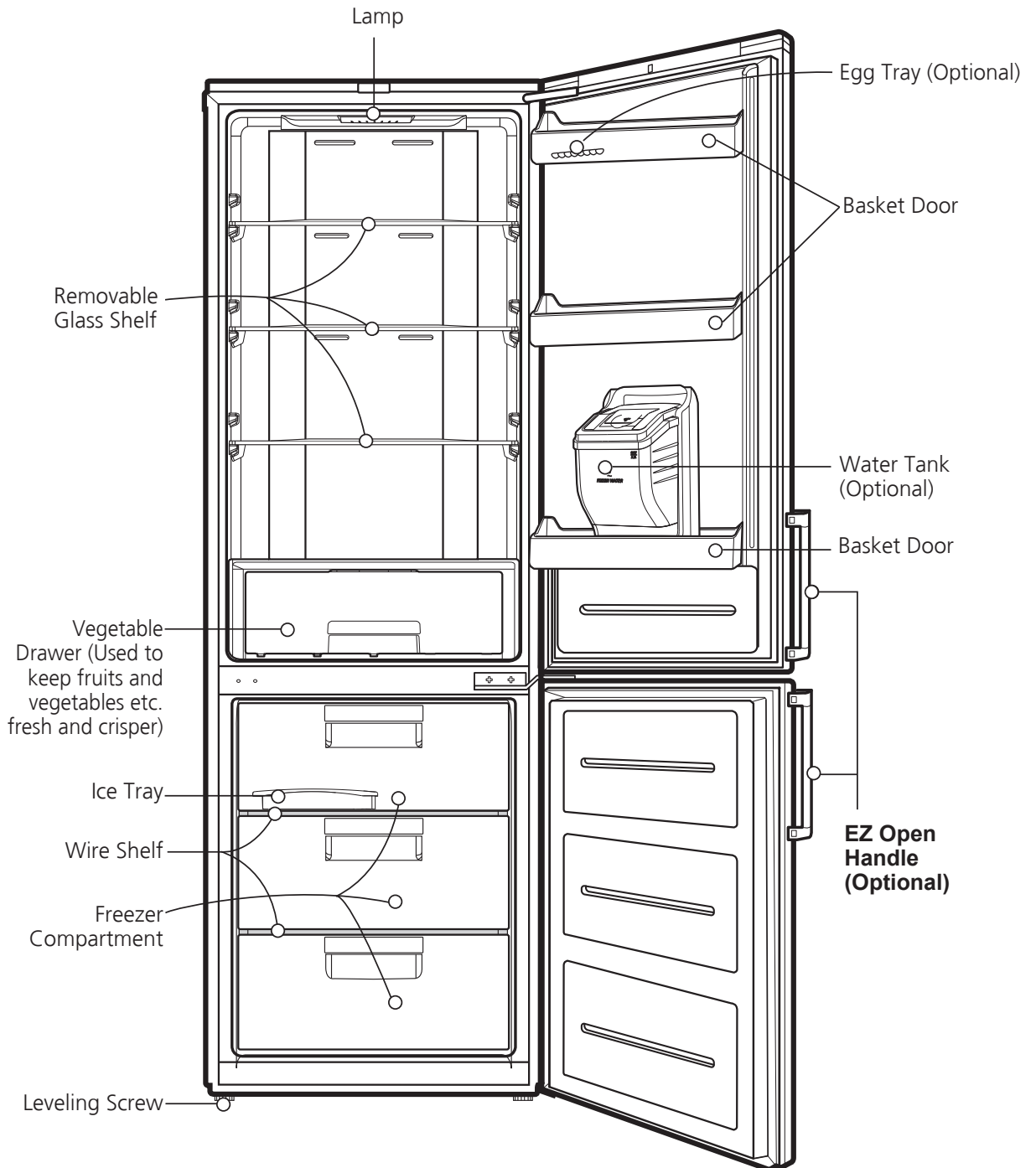

# INSTRUCTIONS FOR REVERSING DOOR SWING

This refrigerator allows the owner to change the door swing if desired. The hinging of the doors can be changed to the opposite side anytime you wish.

## When reversing the door swing :

Read the instructions all the way through before starting.

- Handle parts carefully to avoid scratching paint.
- Set screws down by their related parts to avoid using them in the wrong places.
- Provide a non-scratching work surface for the doors.

## IMPORTANT

Once you begin, do not move the cabinet until door-swing reversal is completed.

These instructions are for changing the hinges from the right side to the left side-if you ever want to change the hinges back to the right side, follow these same instructions and reverse all references to left and right.

Before Removing the Doors, empty and Remove all the Door Baskets of both Refrigerator/Freezer Doors, including the Bank Dairy. Close both doors before removing hinge pins.

## **▲ Warning      Electric Shock Hazard**

Disconnect electrical supply to refrigerator before installing. Failure to do so could result in death or serious injury.

## Caution :

Do not let either door drop to the floor. Doing so could damage the Door Stop.

# INSTRUCTIONS FOR REVERSING DOOR SWING

- 1) Remove screws(3) after removing a CAP(2) from the side of the refrigerator room HANDLE(1).  
The freezer room HANDLE(5) may be also disassembled in a same way as the refrigerator room HANDLE(1).

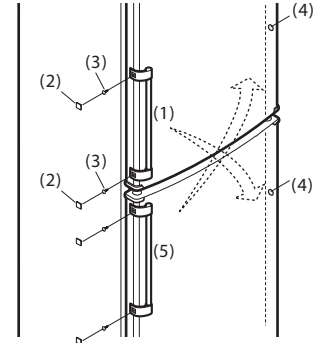

- 2) Remove the screws(6) in the DECO COVER(7).  
Remove the DECO COVER(7) and move the COVER HINGE(8) to side of DECO COVER(7). Disassemble the Housing Connector(9) inside of the DECO COVER(7).

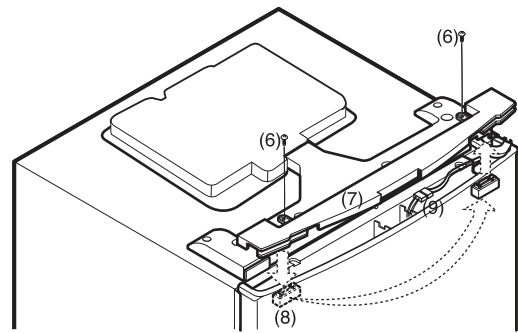

- 3) Remove the screws(10) in the COVER-PWB(11), and remove the COVER-PWB(11).

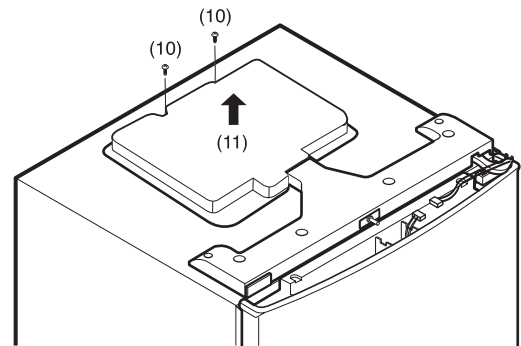

- 4) Remove the screws(12) in the TOP COVER FRONT(13) and remove the TOP COVER FRONT (13).

- 5) Remove the HOLDER CORD (14) placed in right and insert it to center. And then move COVER FRONT(16).  
Take out the HOLDER CORD(spare) (15) and to place in the center of TOP COVER FRONT(13), and insert to the left side.

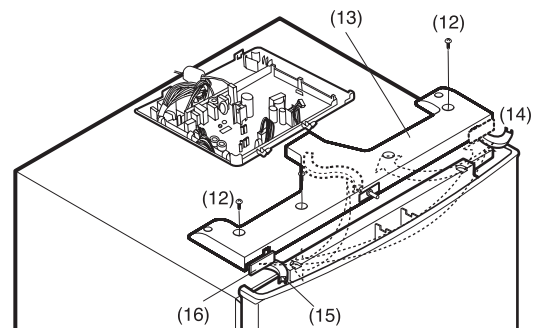

# INSTRUCTIONS FOR REVERSING DOOR SWING

6) Take out the LEAD WIRE(17) assembly from the TOP COVER FRONT(13) and assemble it on the left side.

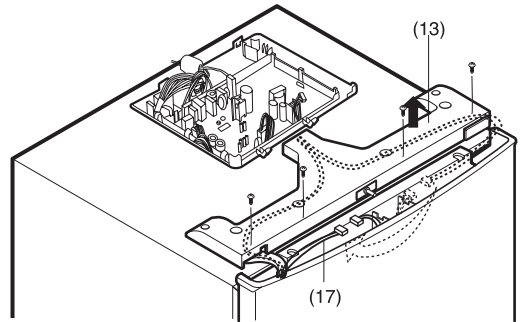

7) Remove bolts(18) securing HINGE-U(19).  
Unscrew of the hinge pin(20).  
Place HINGE-U and seat hinge upside down and apply them to left side of the refrigerator.

**NOTE:**

Seat hinge to be placed under the HINGEU(19).

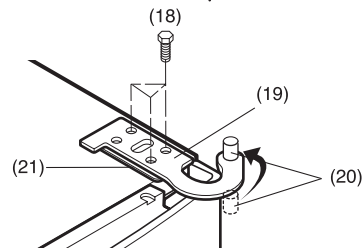

8) Remove bolts(22) securing HINGEC(23) and then remove HINGE-C(23).  
Remove the freezer door. Move in left side of the refrigerator CAP(24). Move to left side of the refrigerator door BRACKET DOOR (25) and screw (26).

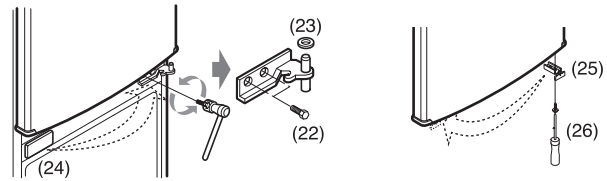

9) Remove Bolts(27), HINGE-L (28), STOPPER (29), (30) and Lavel(31).  
Use the new HINGE-L in Drawer and attach a label to a screw Hole.

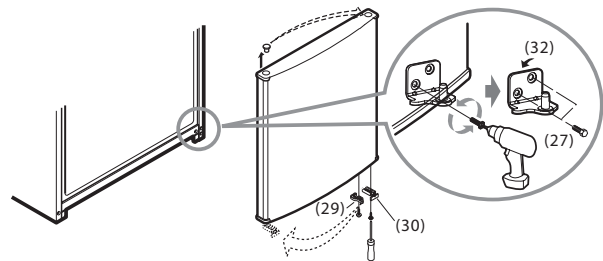

10) Assemble:

HINGE-L → Freezer Door → HINGE-C (23) → Refrigerator Door →  
HINGE-U(19) → TOP COVER FRONT(13) → COVER PWB(11) →  
Connect the Housing Connector(9) → DECO COVER(7) → HANDLE(1) (5)

11) Remove Freezer and Refrigerator Door Gaskets and turn them 180°. Assemble them again and put some lubricant onto their surface.

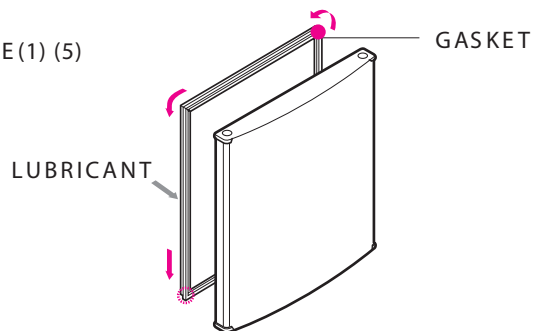

**NOTE:**

Reversing the doors is not covered by the warranty.

# DISASSEMBLY

## 1. DOOR

- Freezer Door
  - 1) Refer to previous chapter "Instruction for Reversing Door Swing".
  - 2) Pull out Door Gasket to remove from the Door Foam Assembly, F.

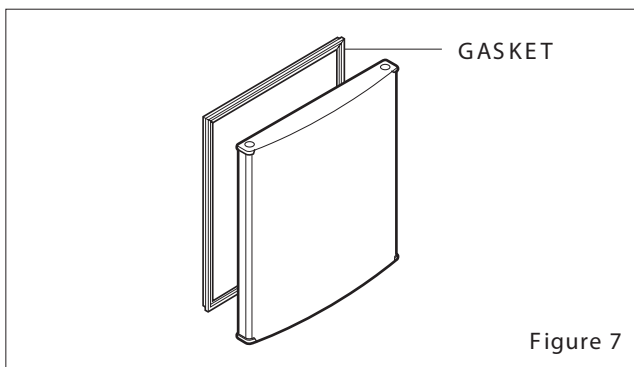

- Refrigerator Door
  - 1) Refer to previous chapter "Instruction for Reversing Door Swing".
  - 2) Pull out the Door Gasket to remove from the Door Foam Assembly, R.

## 2. DOOR SWITCH

- 1) Unplug the power cord from the outlet.
- 2) Loosen six screws in upper part and disconnect Top Cover Front.
- 3) Disconnect Lead Wire from switch.
- 4) Disengage hook behind the switch by pressing it with hands.

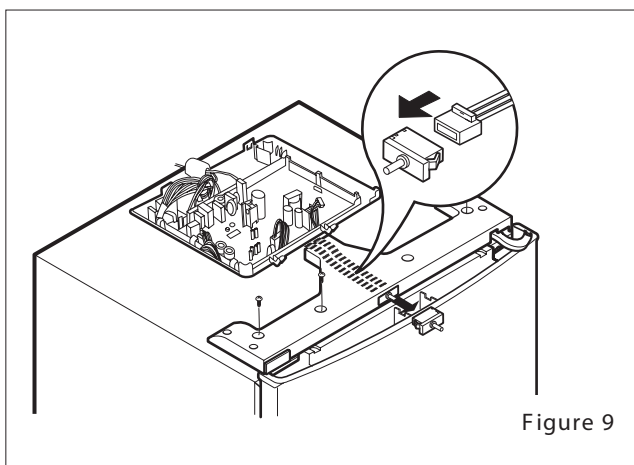

## 3. FAN AND FAN MOTOR

- 1) Remove all of the freezer compartment, (Involved wire shelf, ice maker)
  - 2) Pull out the Grille Fan and Shroud F.
  - 3) Disconnect the Housing of lead wire.
  - 4) Remove three screws in Grille Fan.
  - 5) Separate Shroud, F to the Grille Fan.
  - 6) Loose three screws fixed to the Bracket.
  - 7) Pull out Bracket and then remove the Fan Motor Assembly.
- \* Fan Motor Assembly can't separate.

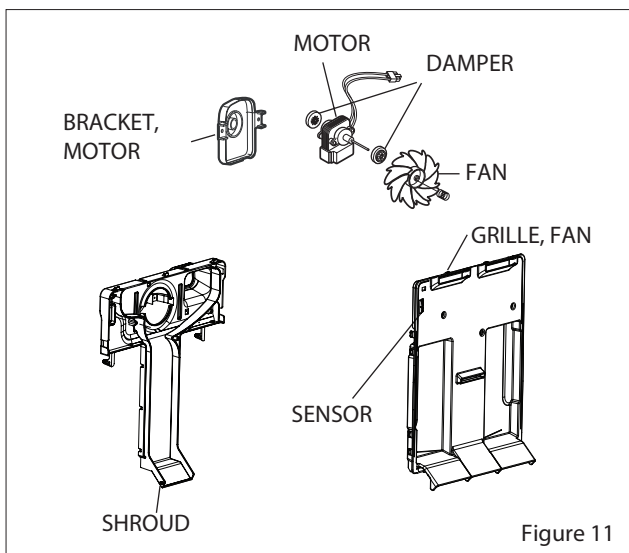



# DISASSEMBLY

---

## 4. DEFROST CONTROL ASSEMBLY

Defrost Control Assembly consists of Thermistor and Fuse, Melting. Thermistor functions to defrost automatically and it is attached to metal side of the Evaporator and senses temperature.

Fuse, Melting is a kind of safety device for preventing overheating of the Heater when defrosting.

At the temperature of 77°C, it stops the emission of heat from the Heater.

- 1) Pull out the Shroud, F after removing the Grille.  
- Freezer  
Pull out the Grille. - Fridge
- 2) Separate the connector connected with the Defrost Control Assembly and replace new one.

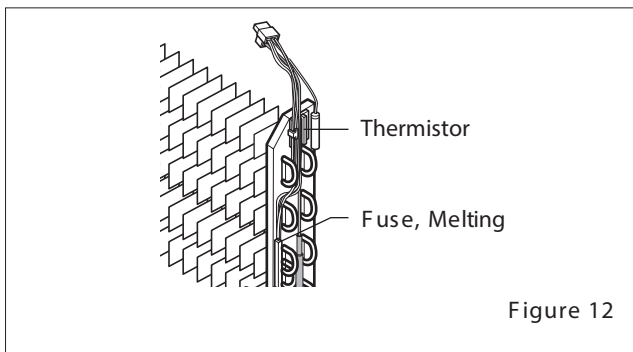

## 5. FREEZER HEATER, SHEATH

In this refrigerator, Heater, Sheath is used for defrosting heater. During heating, the temperature of heater rises about 300~350°C. Therefore, be careful not to burn while servicing.

- 1) After removing the Grille and Shroud, separate the Heater, Sheath by disconnecting the connectors.
- 2) Exchanged Heater, Sheath and connected the housing.

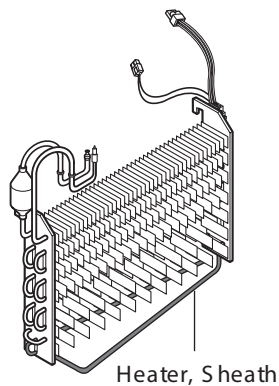

# ADJUSTMENT

## 1. COMPRESSOR (In A++ and A+ Models)

### 1) Role

The compressor intakes low temperature and low pressure gas evaporated from Evaporator of the Refrigerator, and condenses this gas to high temperature and high pressure gas, and then plays delivering role to Condenser.

### 2) Composition

The Compressor is Composed of Compressor Apparatus compressing gas, Compressor Motor moving Compressor Apparatus and Case protecting Compressor Apparatus and Motor. There is Relay Assembly (one set of PTCs starter and Over Load Protector (OLP)) in Compressor. On the other hand, because the Compressor consists of 1/1000mm processing precision components and is sealed after production in absence of dust or humidity, deal and repair with care.

### 3) Note for Usage

- (1) Be careful not to allow over-voltage and over-current.
- (2) No S strike  
If applying forcible power or strike (dropping or careless dealing), poor operation and noise may occur.
- (3) Use proper electric components appropriate to the Compressor.
- (4) Note to Keep Compressor.  
If Compressor gets wet in the rain and rust in the pin of Hermetic Terminal, the result may be poor operation and poor contact may cause.
- (5) Be careful that dust, humidity, and flux welding don't inflow in the Compressor inside in replacing the Compressor. Dust, humidity, and flux due to welding which inflows to Cylinder may cause lockage and noise.

## 2. PTC-STARTER (In A++ and A+ Models)

### 1) Composition of PTC-Starter

- (1) PTC (Positive Temperature Coefficient) is a no-contact semiconductor starting device which uses ceramic material and this material consists of  $BaTiO_3$ .
- (2) The higher the temperature is, the higher becomes the resistance value. These features are used as starting device for the Motor.

### 2) Role of PTC-Starter

- (1) PTC is attached to Hermetic Compressor used for Refrigerator, Show Case and starts Motor.
- (2) Compressor for household refrigerator applies to single-phase induction Motor.  
For normal operation of the single-phase induction motor, in the starting operation flows in both main coil and sub-coil. After the starting is over, the current in subcoil is cut off. The proper features of PTC play all the above roles. So, PTC is used as a motor starting device.

### 3) PTC-Applied Circuit Diagram

- According to S starting Method for the Motor

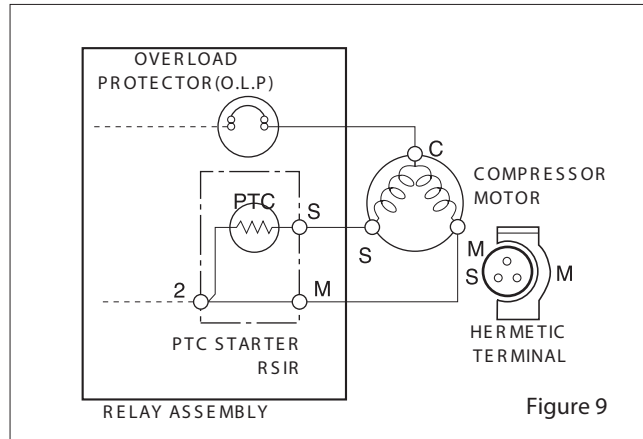

### 4) Motor Restarting and PTC Cooling

- (1) For restarting after power off during normal Compressor Motor operation, plug the power cord after 5 min. for pressure balance of Refrigerating Cycle and PTC cooling.
- (2) During normal operation of the Compressor Motor, PTC elements generate heat continuously. Therefore, if PTC isn't cooled for a while after the power has been shut off, Motor can't operate again.

### 5) Relation of PTC-Starter and OLP

- (1) If the power is off during operation of Compressor and the power is on before the PTC is cooled, (instant shutoff within 2 min. or reconnect a power plug due to misconnecting), the PTC isn't cooled and a resistance value grows. As a result, current can't flow to the subcoil and the Motor can't operate and the OLP operates by flowing over current in only in the main-coil.
- (2) While the OLP repeats on and off operation about 3-5 times, PTC is cooled and Compressor Motor performs normal operation.  
If OLP doesn't operate when PTC is not cooled, Compressor Motor is worn away and causes circuitshort and fire. Therefore, use a properly fixed OLP without fail.

### 6) Note to Use PTC-Starter

- (1) Be careful not to allow over-voltage and over-current.
- (2) No S strike  
Don't apply a forcible power or strike.
- (3) Keep apart from any liquid.  
If liquid such as oil or water away enter the PTC, PTC materials it may break due to insulation breakdown of the material itself.
- (4) Don't change PTC at your convenience.  
Don't disassemble PTC and mold. If the exterior to the PTC-starter is damaged, resistance value is altered and it may cause poor starting of the compressor motor may cause.
- (5) Use a properly fixed PTC.

# ADJUSTMENT

## 3. OLP (OVER LOAD PROTECTOR)

(In A++ and A+ Models)

### 1) Definition of OLP

- (1) OLP (OVER LOAD PROTECTOR) is attached to the Hermetic Compressor and protects the Motor by cutting off current in Compressor Motor in case of over-rising temperature by Bimetal in the OLP.
- (2) When over-voltage flows to Compressor motor, the Bimetal works by heating the heater inside the OLP, and the OLP protects Motor by cutting off current which flows to the Compressor Motor.

### 2) Role of the OLP

- (1) The OLP is attached to the Hermetic Compressor used for the Refrigerator and Show Case and prevents the Motor Coil from being started in the Compressor.
- (2) Do not turn the Adjust Screw of the OLP in any way for normal operation of the OLP.  
(Composition and connection Diagram of OLP)

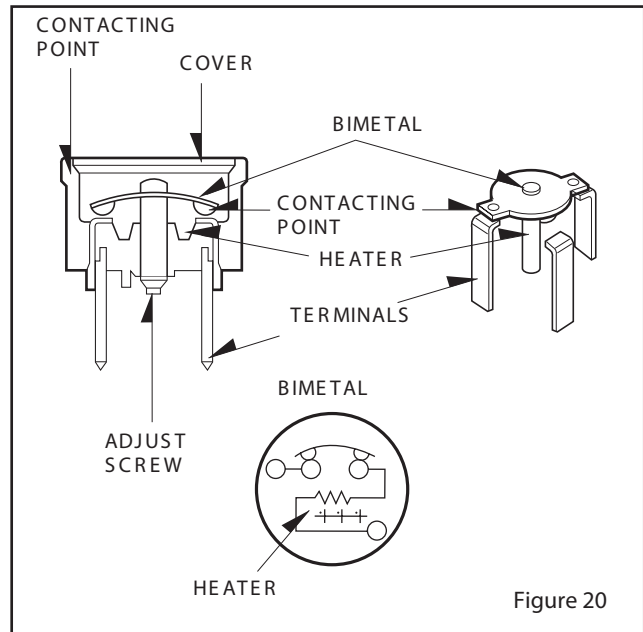

Figure 20

# COMPRESSOR

## 1. Inverter Linear Compressor

Check for defect of the inverter linear compressor in following orders:

### 1) Method to Measure Compressor Winding Resistance

Normal Determination Criteria.

The compressor winding resistance can be determined as normal if resistance values show the values as described in below figure when measuring resistance values of the harness (connected with compressor) to connect.

Connect201(CON201) of the main PWB as shown in below figure.

#### Defect Determination Criteria

- Check connection status of the Compressor Connection Harness-P(Lead Wire) which is located at the M/C room where resistance values measured at the CON201 Housing are shown as infinite or several hundred MΩ . Separate connecting wires of the M/C room (A-point in Figure) and then measure resistance values at the connecting wires again. The compressor can be determined as normal if resistance values are shown as standard resistance value. Check connection status of a harness.  
Defect at M/C room connection contact or CON201 Housing contact, short-circuit of harness)
- Where resistance values measured at A-point are also shown as infinite or several hundred MΩ , disassemble a cover PTC of the compressor terminal and check the terminal connecting status at the B-point in Figure.
- Where there is no failure in the wiring status and resistance values are shown as infinite or several hundred MΩ , it may be determined as defect of compressor.
- Since if there is no failure in resistance values of the compressor, it may be defective Main PWB, replace the Main PCB and check for normal operation of the compressor.
- When determining any defect through resistance measuring, it can be determined as normal if resistance values show as described in the below figure by measuring ① power and ③ common terminal or ② full power and ③ common terminal. However, resistance values are measured when measuring ① power and ② full but measuring is meaningless since they cannot become criteria for determining defect (measuring not required).

#### Caution

1. Be sure to powering off the refrigerator and measure after several minutes has passed.
2. If not accurately measuring resistance, wrong determination may be guided. (Difference of resistance value of several W or so may occur.)

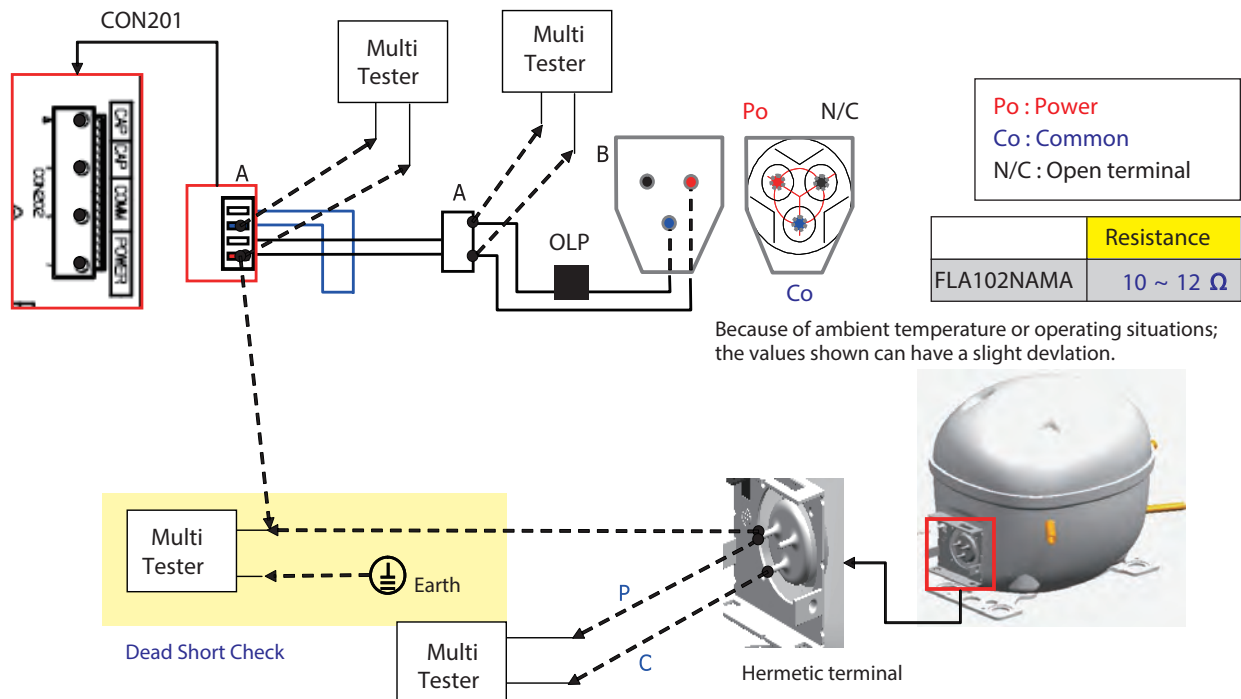

# COMPRESSOR

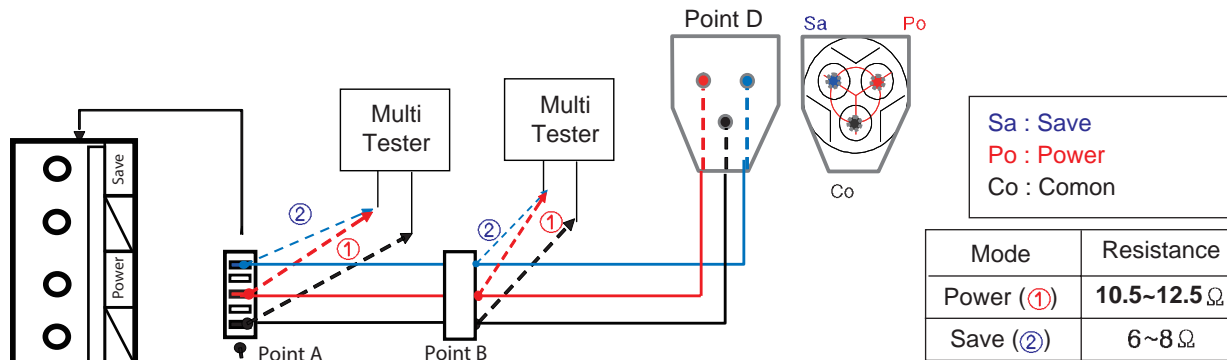

※ Because of ambient temperature or operating situations; the values shown can have a slight deviation.

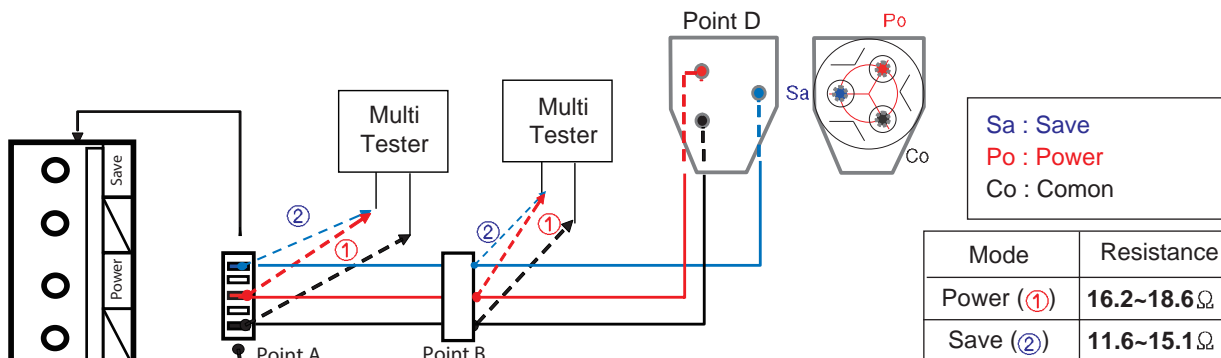
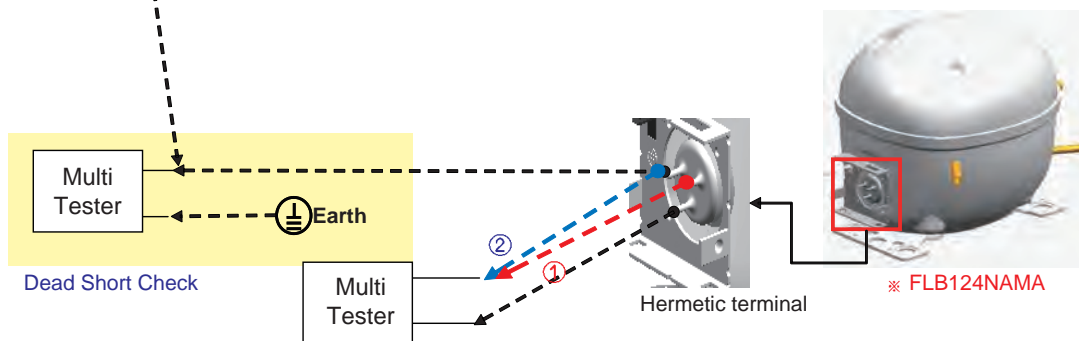

※ Because of ambient temperature or operating situations; the values shown can have a slight deviation.

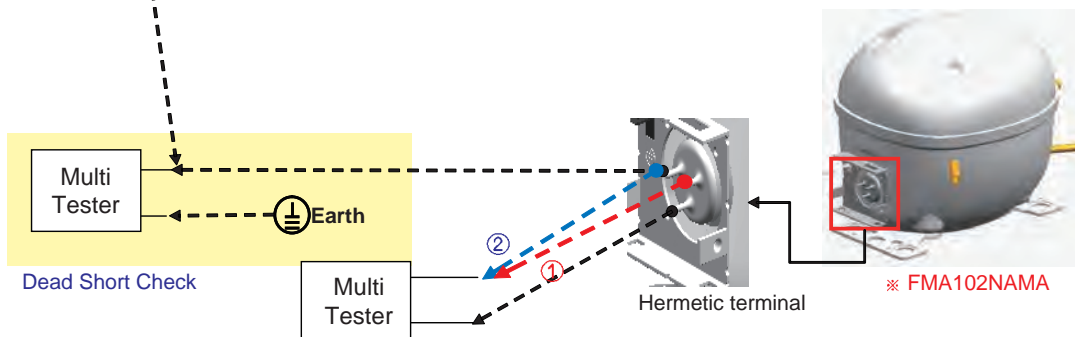

# COMPRESSOR

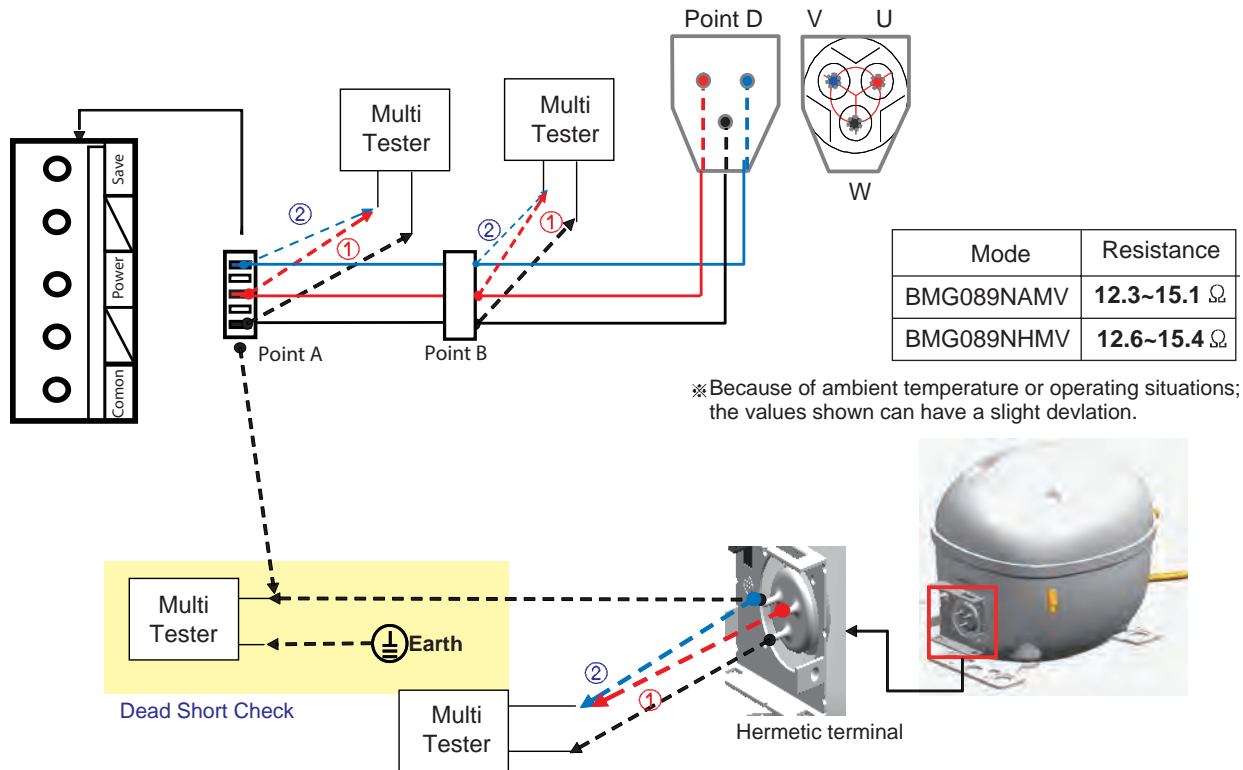

## 2) Method to Determine Defect of Inverter Linear Drive

### Determination of Comp Operation

Separate the back cover at the rear of refrigerator and determine for possible operation while touching the compressor with the hands with insulation gloves worn.

### Comp Operation

- Determine possible trip by checking operation status if cold air comes out after opening the doors of the R-Room.

### Protective Logic (Trip)

- To protect the compressor from abnormal operation, this logic is used to temporarily stop the refrigerator when abnormal operation occurs and to re-operate it after abnormal signal disappears.

### Compressor protection Logic Table

	App.	Requirement	Waiting Time	The number of LED blinking
FCT0 Trip	A-Inv.	Initial, Motor sensing Voltage > 2.5V+20%	30"	1
Stroke Trip	A-Inv.	Piston overruns the designed range.	1'00"	2
Locked Piston Trip	A-Inv.	Piston is locked.	2'30"	5
Current Trip	A-Inv.	Current overruns the designed range	6'00"	6
IPM Fault	A-Inv.	IPM pin 14 output voltage = low (IPM Short, High current input, or low voltage input)	20"	7
Communication Error	A-Inv.	Checksum error	-	8

\* If LED of PCB is blinking, Refer to next page.

# COMPRESSOR

---

3) LED blinks one time, then repeats (FCTO Trip)



- FCTO : When same trip occurs after power reset, change PCB.
- Because it is occurred by overvoltage (more than 2.5V) at voltage and current sensing parts, PCB has to be changed.

# COMPRESSOR

## 4) LED blinks two times, then repeats (Stroke Trip)



- Purpose: Prevent abnormally long piston strokes.
- Case 1. If compressor doesn't work and LED blinks
  - Cause: Possibly harness from compressor to PCB might be defective.
- Case 2. If compressor works intermittently and LED blinks
  - Cause: Condenser Fan or Freezer Fan is not running. Sealed system problem such as moisture restriction, restriction at capillary tube or refrigerant leak.
- Logic: Compressor is forced to off and then tries to restart after 1 minute.

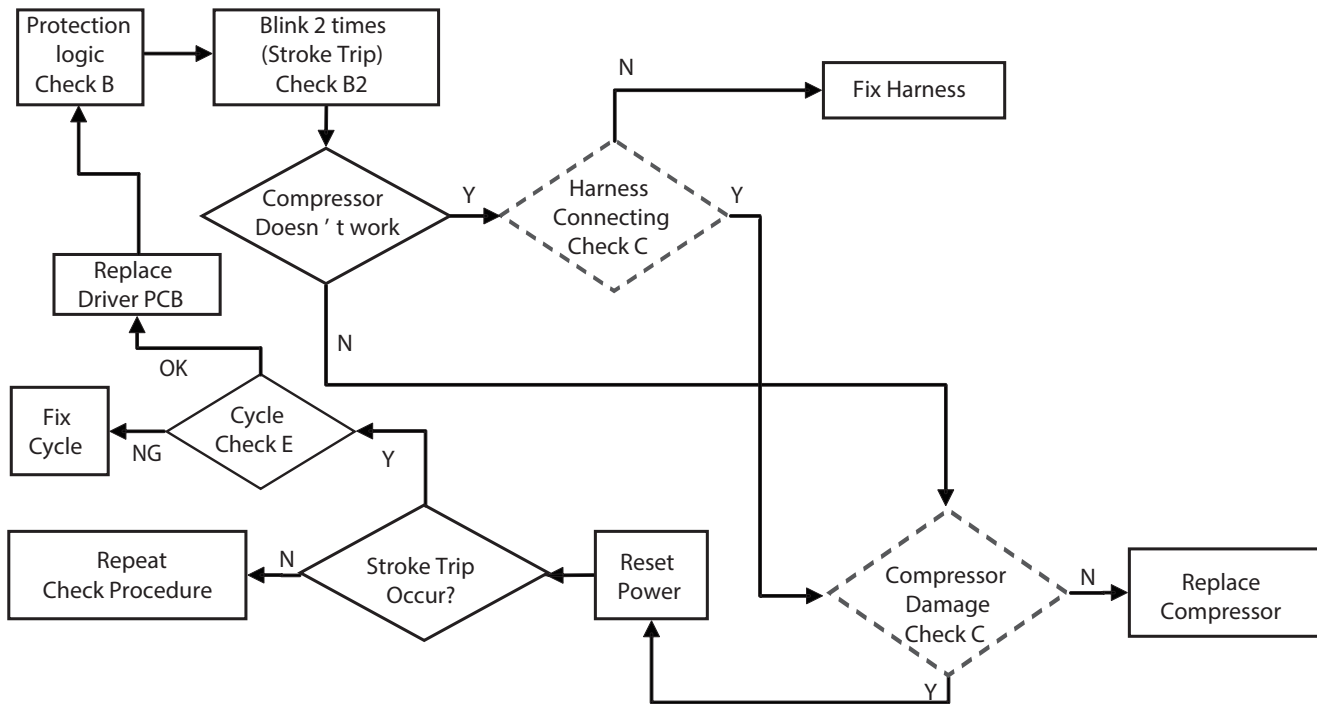



# COMPRESSOR

5) LED blinks five times, then repeats (Locked Piston)



Blink Blink Blink Blink Blink OFF

- Purpose: To detect locked piston
- Cause: Lack of oil to the cylinder, cylinder or piston damaged and or restricted discharge.  
A Locked Piston can also be caused by foreign materials inside the compressor.
- Logic: Compressor is forced off and tries to restart within 2.5 minutes.

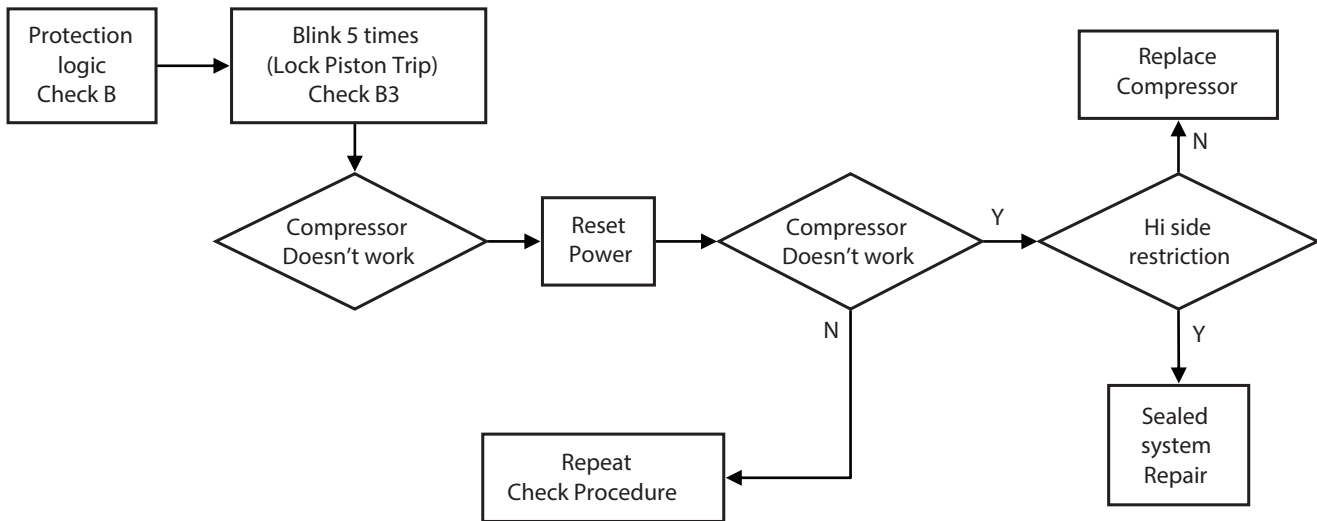

# COMPRESSOR

6) LED blinks six times, then repeats (Current Trip)



- Purpose: Prevent over-current (overload protect)
- Cause: Ambient temperature is high (over 43°C) and/or refrigerator's condenser air movement is restricted.
- Condenser Fan is stopped, restricted discharge line, compressor is damaged, or IPM device is defective.
- Logic: Compressor is forced off and tries to restart after 6 min.

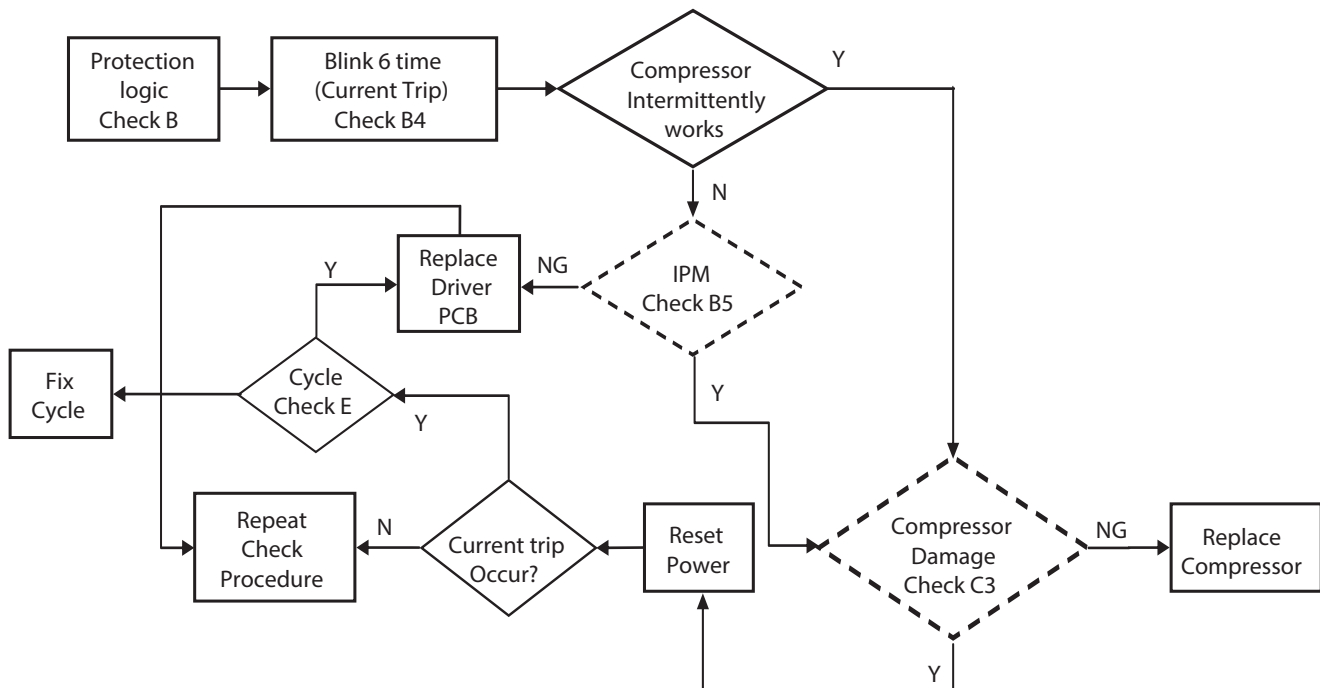

# COMPRESSOR

7) LED blinks seven times, then repeats (IPM Fault)



Blink Blink Blink Blink Blink Blink Blink OFF

- Purpose: Prevent high current due to IPM Short
- Cause: Damaged IPM (Dead Short)
- Test for a dead short at Point A with a VOM.
- Logic: Compressor is forced off and tries to restart after 20 sec.

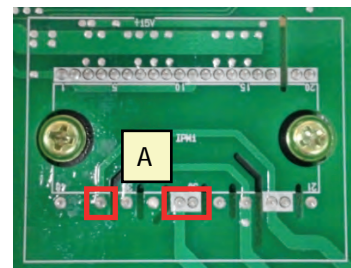
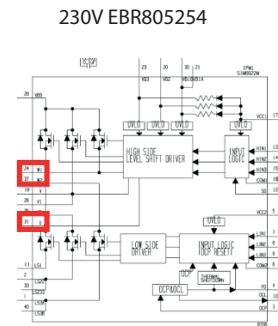
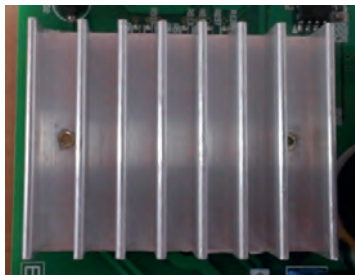
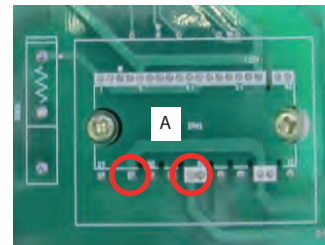
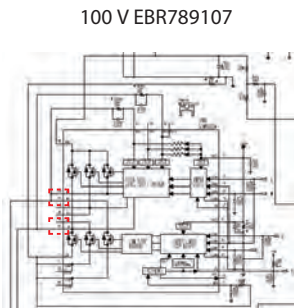
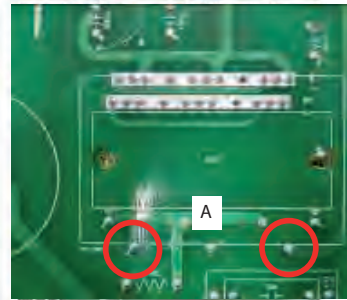
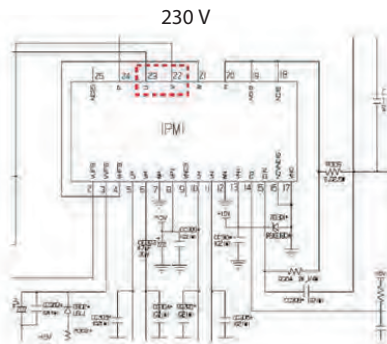

# COMPRESSOR

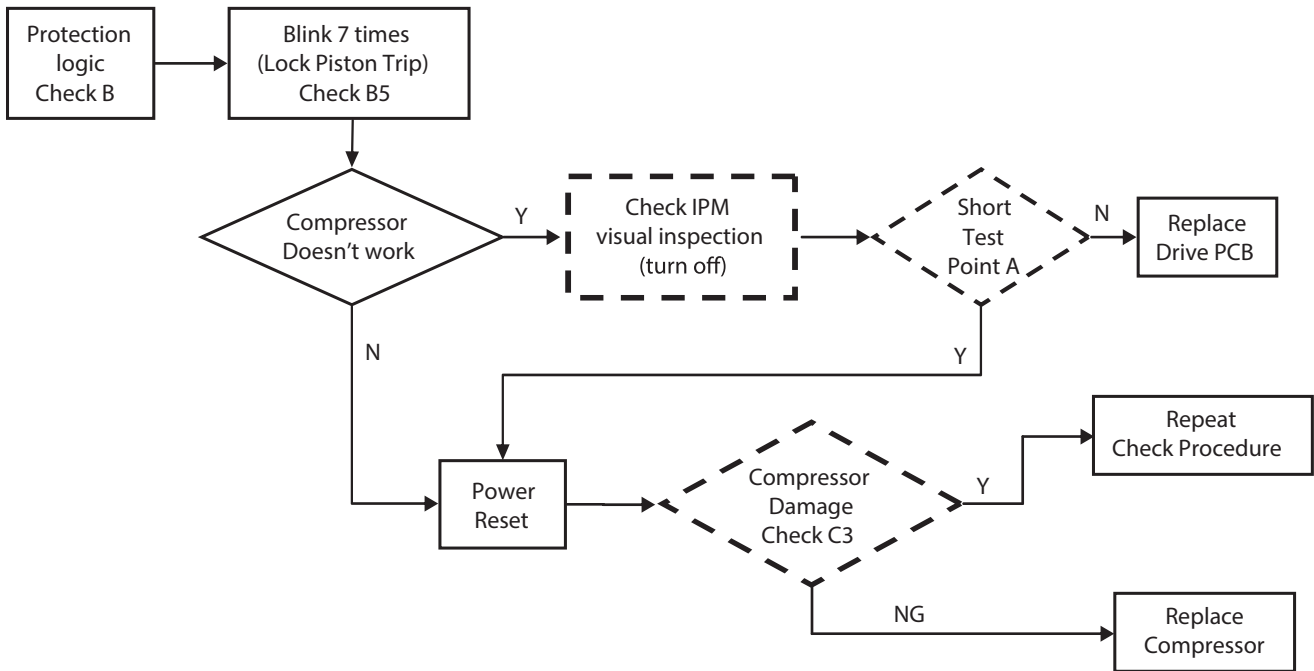

8) LED blinks eight times, then repeats (Communication Error)

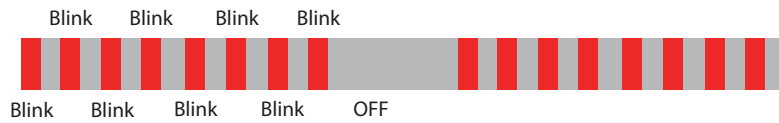

- Communication Error : When same trip occurs after power reset, change PCB.
- Because Program is not matching in MICOM, program has to be rewritten or PCB has to be changed.

# Heavy Repair Method of Refrigerator by Application of Refrigerant

## 1. Outline

### 1) Checkpoints before Heavy Repair

Open the Cover ASM, Back-M/C of refrigerator and check the type of refrigerant indicated on a compressor before starting work. A yellow label is adhered to the compressor for the refrigerator using R600a as refrigerant.

### 2) Features of R600a Refrigerant

- Non-polar natural gas refrigerant ( $\text{CH}(\text{CH}_3)_3$ )
- Since R600a is same series as butane gas, there is danger of fire when discharged into air at appropriate concentration (extreme handling is required for heavy repair of cycle).  
Explosion concentration: .8% ~ 8.4%/Vol.  
Burning temperature: 494°C

### 3) Features of R600a Refrigerant

- With refrigerant quantity of 60% or so for the refrigerator using R134a as refrigerant
- Large vacuum level at suction pressure (at low pressure side)
- COMP capacity of the refrigerator using R600a as refrigerant is large by 1.7 times than that of the refrigerator using R134a.
- Labels as in Figure are displayed at the compressor of a refrigerator for R600a and the back plate of refrigerator.

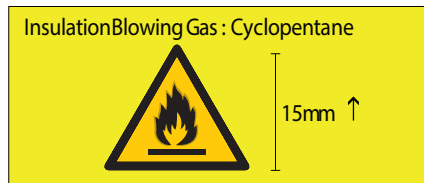

[Warning sign according to ISO 7010 021]



### 4) Location and Environment for Heavy Repair

- Check that drafting and air ventilation are well done at a working area and perform work after making drafting and air ventilation smooth (use refrigerant return bag indoors).
- Check that there are fire appliances or heating source around the working area and then remove them before work.
- Since R600a refrigerant is very inflammable, they should not be discharged indoors.
- Be sure to follow heavy repair SVC procedures during work.

### 5) Heave Repair Work Tool

- R600a refrigerant
- Bombe
- Pinch Pliers
- Refrigerant Discharge Hose
- Refrigerant Return Bag
- Vacuum Pump
- Handy Welding Machine
- Charging Tube
- Leakage Tester
- Drier

# Heavy Repair Method of Refrigerator by Application of Refrigerant

## 2. Heavy Repair SVC Method

For the heavier repair of R600a type of refrigerator, perform work according to following SVC method.

### 1) Return of Refrigerator Refrigerant

Required equipment: Pinch pliers, refrigerant discharging hose, refrigerant return bag

- Take power cords out and remove power between 6sec through 12sec after powering ON to open all both sides of 3way valve.
- Leave doors of a refrigerator so that they are not closed.
- Connect pinch pliers with a refrigerant discharging hose.
- Place the outlet of a refrigerant discharging hose outside.  
(Remove fire appliances or heating sources near a refrigerant discharging hose.)
- Always use a refrigerant return bag for working at the contained space.
- Bore the charging pipe of a compressor with pinch pliers.  
(Remove fire appliances or heating sources near a refrigerator.)
- Perform refrigerant discharge for more than 7 minutes.

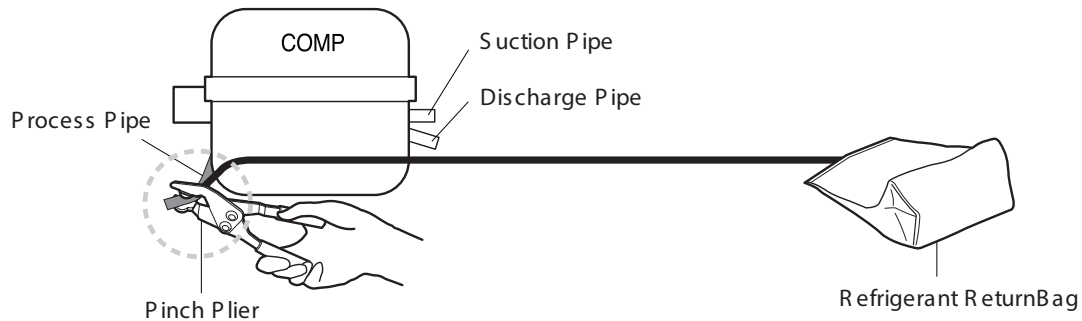

# Heavy Repair Method of Refrigerator by Application of Refrigerant

## 2) Return of Remained Refrigerant

Required equipment: Pinch pliers, hose for refrigerant recovery, vacuum pump

- If refrigerant return time of 7 minutes has passed, connect a vacuum pump at the ends of a refrigerant return hose outdoor. (Vacuum pump must operate outdoor.)
- Operate a vacuum pump in order to return refrigerant remained in the pipe.
- Vacuum working time should be for more than 10 minutes.

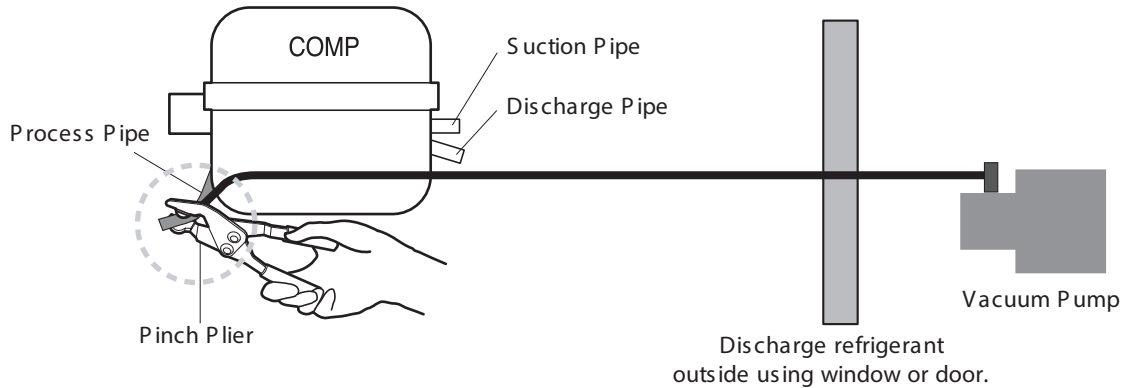

## 3) Welding Repair Step

Required equipment: Simple welding machine

- Remove pinch pliers if remaining refrigerant return is completed.
- Cut the front part of a process pipe with a cutter. (Check that remaining refrigerant comes out.)
- Perform welding work such as replacement of compressor and dryer, or repair of leakage part. (Be cautious of fire during welding work.)



# Heavy Repair Method of Refrigerator by Application of Refrigerant

---

## 4) Charging Tube Connection Step

Required equipment: Charging tube, simple welding machine

- Remove a charging pipe to recharge R600a refrigerant after completing work, and then connect a charging tube with welding

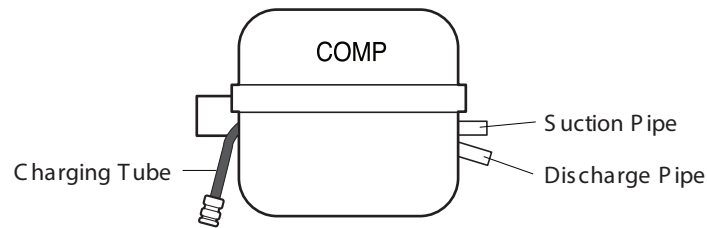

## 5) Vacuum Air Removal

Required equipment: Vacuum pump

- Connect a vacuum pump to a charging tube to perform vacuum cycle.
- Vacuum work should be performed for an hour. (If vacuum time is short, normal cooling performance may not be exerted due to failure of cooling cycle.)





# Heavy Repair Method of Refrigerator by Application of Refrigerant

---

## 6) Refrigerant Charging

Required equipment: Bombe, R600a refrigerant (67g)

- Firstly remove fire appliances and heating source for performing work when charging scaled refrigerant. (Do not spray refrigerant indoor.)
- Measure the accurate quantity (67g) of refrigerant to charge it into a Bombe.
- Make the Bombe as vacuum status to charge refrigerant.  
(If there is air or moisture in a Bombe, it may give effect on performance of a cooling cycle.)
- Please manage refrigerant quantity as  $67g \pm 1$ . Differently from R134a, R600a gives much effect on cooling performance depending on change of refrigerant quantity.

Refrigerant quantity = Weight after charging - Weight before charging (weight of vacuumed Bombe)

- Connect Bombe with a charging tube to charge refrigerant.
- Turn on power of refrigerator to operate a compressor.
- Measure Bombe weight after 5 through 10 minutes to check remained refrigerant quantity to complete charging of refrigerant.  
(After charging refrigerant, never perform welding work or work using fire appliances.)

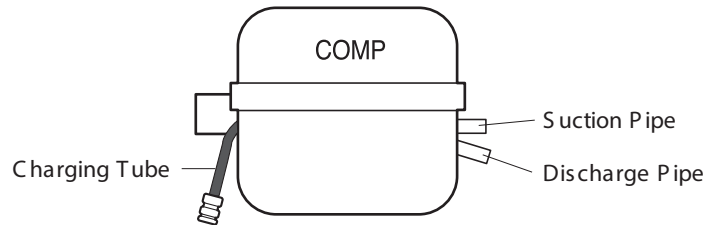

## 7) Leak Inspection and Cycle Check

Required equipment: Leakage checking machine (foam and leakage inspection machine)

- Check for leakage by using foam or a leakage inspection machine at the worked part if charging of refrigerant is completed.
- Check for leakage at the low pressure part with the compressor stopped, and check at the high pressure part with the compressor being operating.
- If leakage is detected, proceed to repair according to repair process again starting from "2-1. Return of Refrigerant".  
(Never perform welding work or work using fire appliances.)
- Check that heat remains at a discharge pipe or condenser with the hands if leakage check is completed. If heat remains, the cooling cycle is normal.  
(Take care since a discharge pipe may be hot.)

# Heavy Repair Method of Refrigerator by Application of Refrigerant

## 8) Failure Checking Procedures

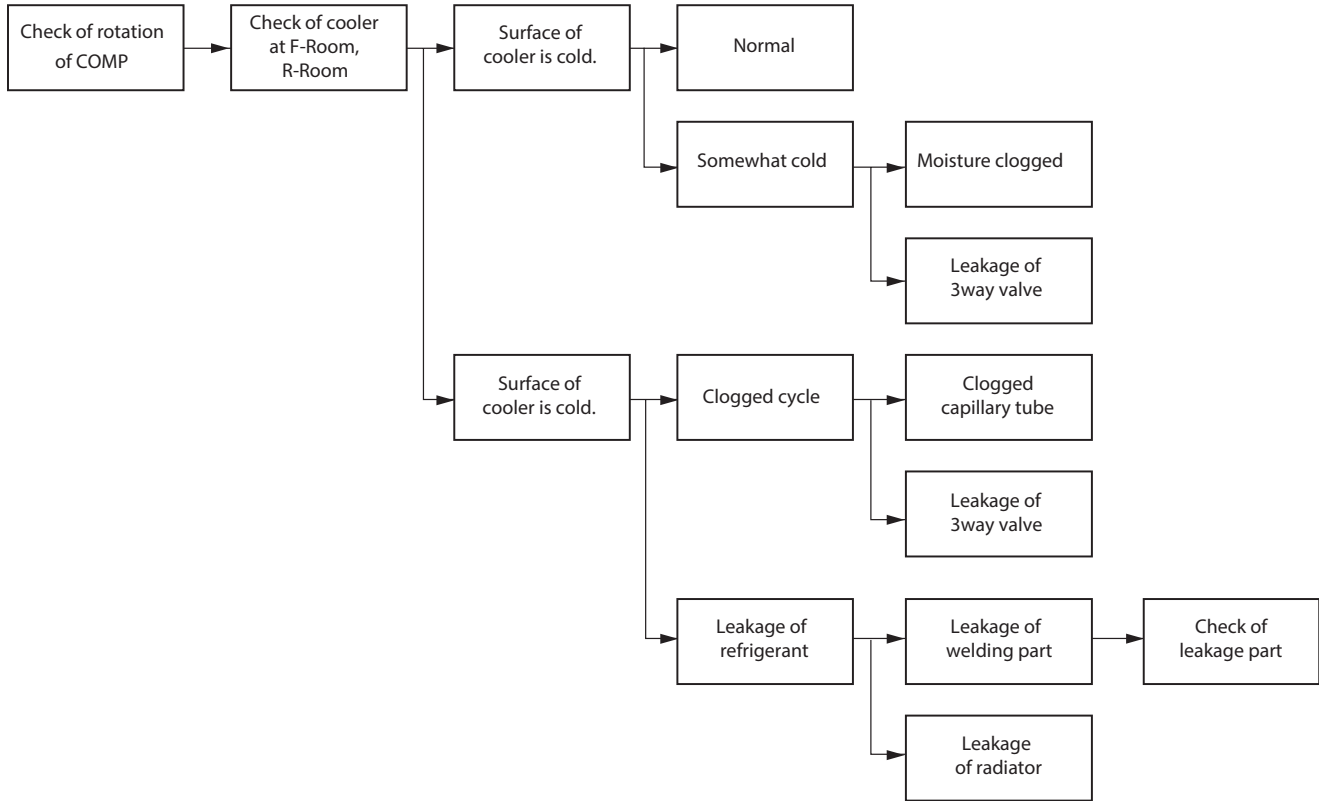

## 9) Cautions in Heavy Repair Service

Special caution should be taken since fire may occur for welding work since refrigerant may remain as it is at the high pressure side even after vacuum air-discharge in relation with cycle clogging. Take power cords out and remove power between 6sec - 12sec after powering on in order to open both sides of 3way valve in the step of refrigerant recovery. If both sides of 3way valve will not be opened, fire may occur during welding work since refrigerant may remain during the cycle. To prevent moisture clogging, always replace dryer together during heavy repair of refrigerator.

# CIRCUIT DIAGRAM

A+++

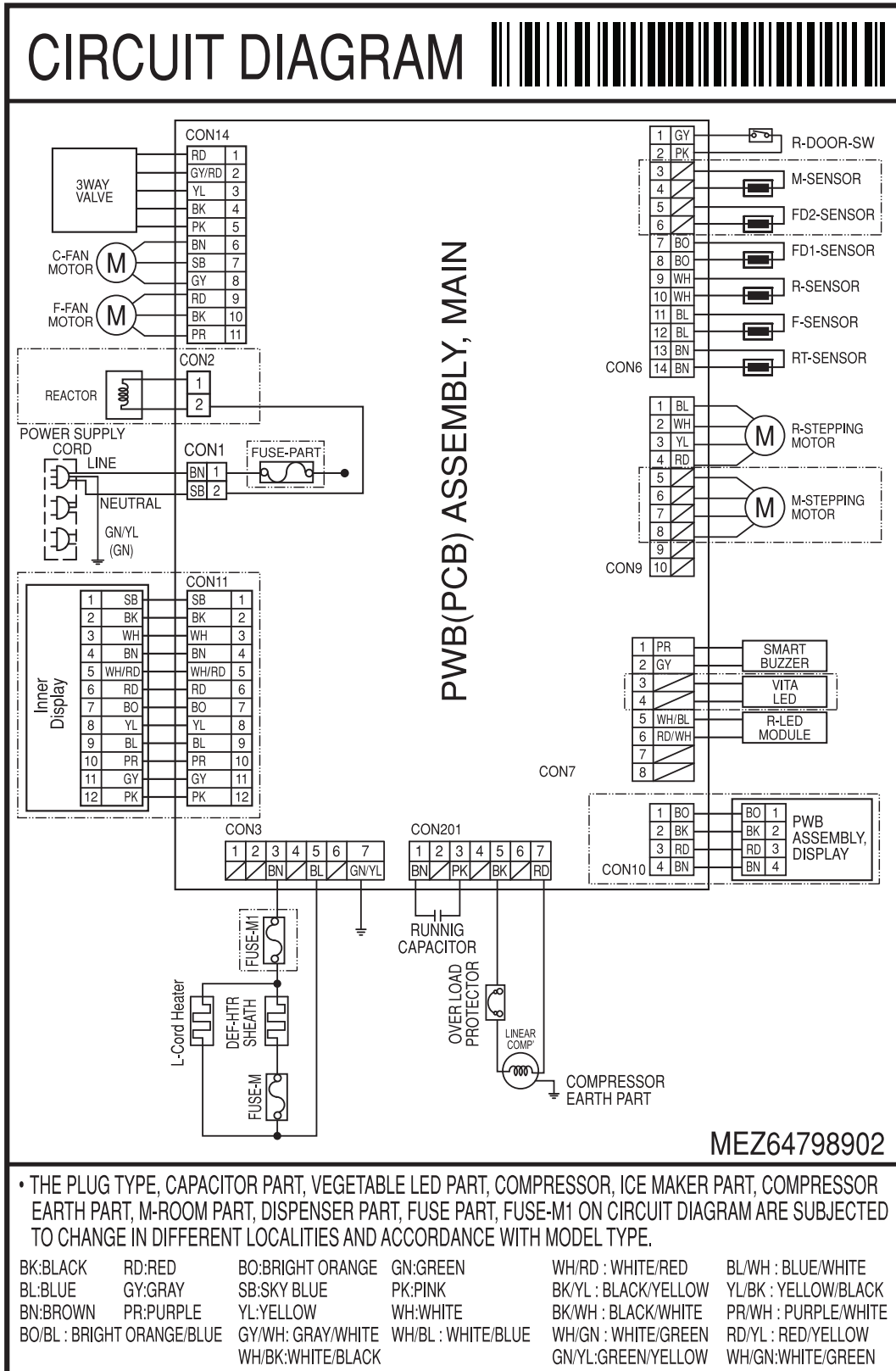

# CIRCUIT DIAGRAM

Linear A++

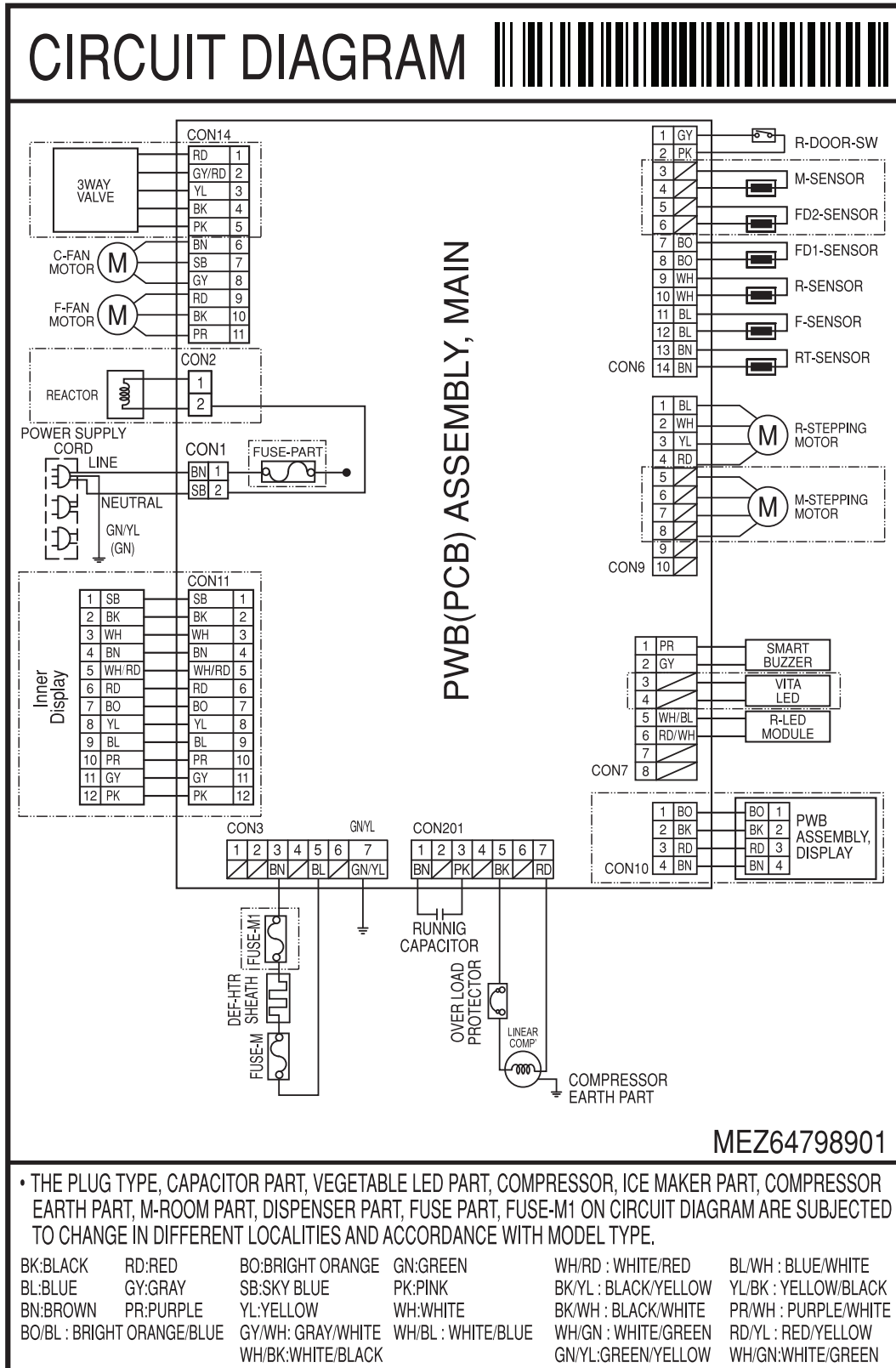

# CIRCUIT DIAGRAM

Linear A++ FLB compressor

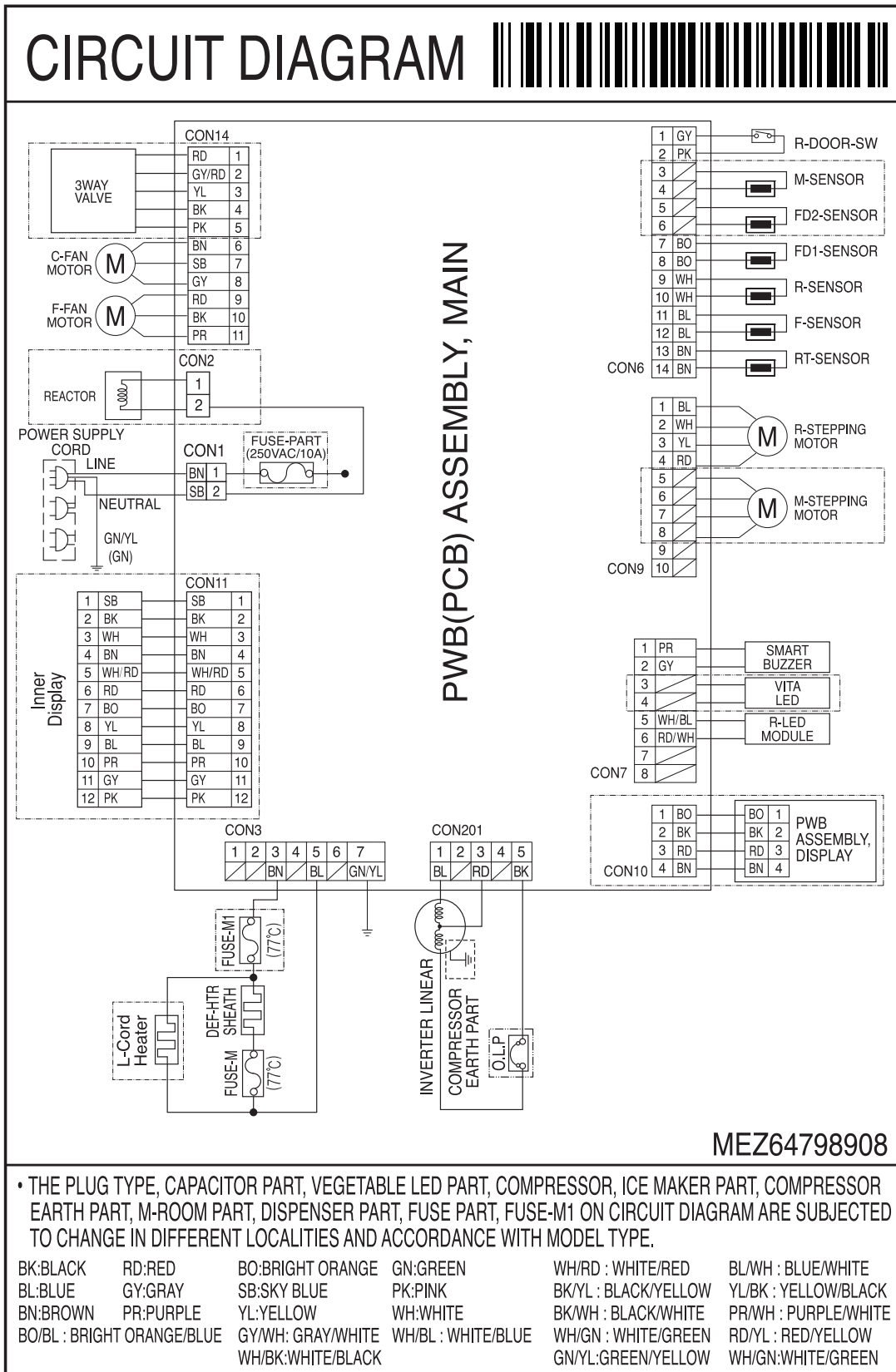

# CIRCUIT DIAGRAM

Linear A++ FLB compressor spanish

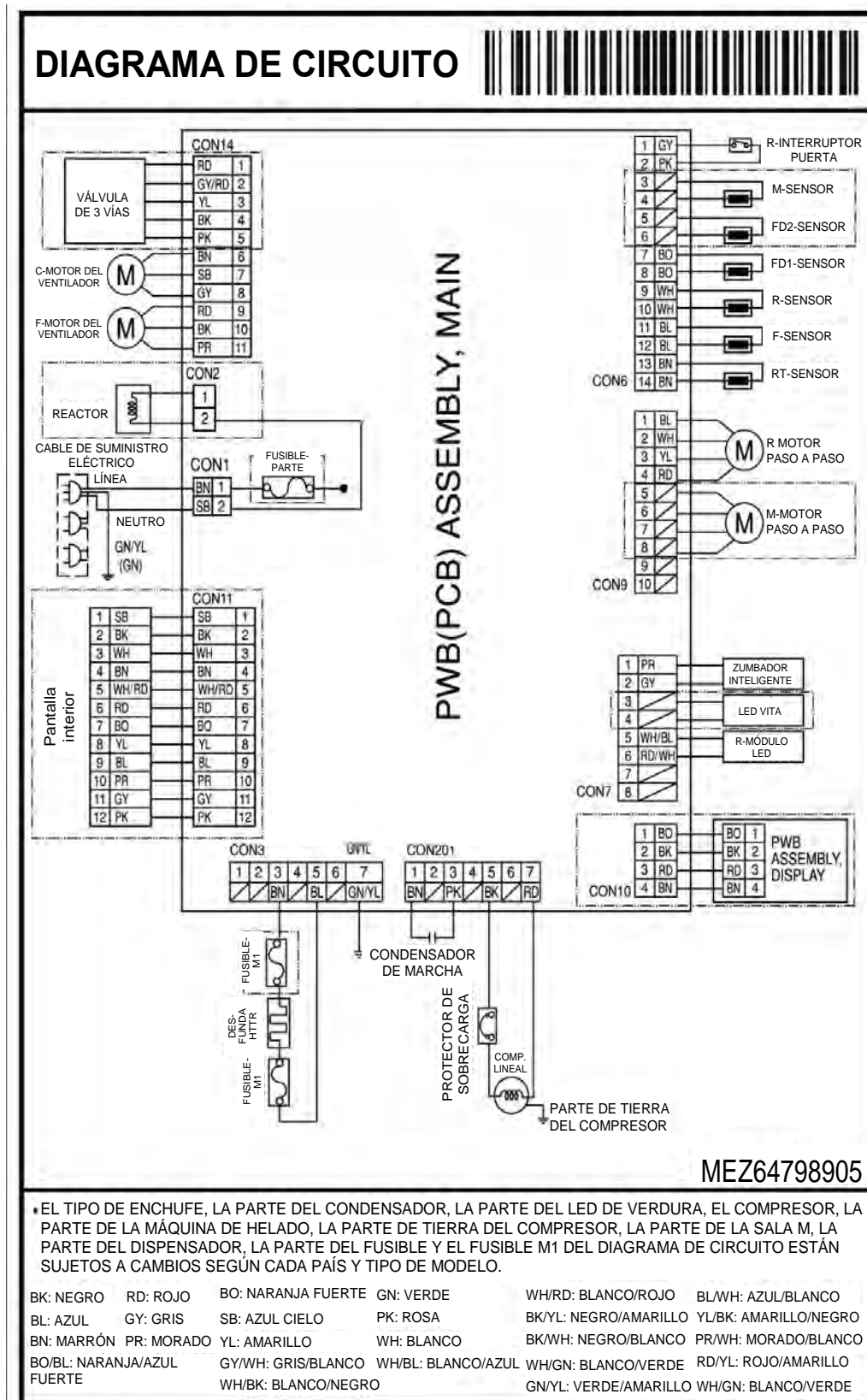

# CIRCUIT DIAGRAM

A++,A+

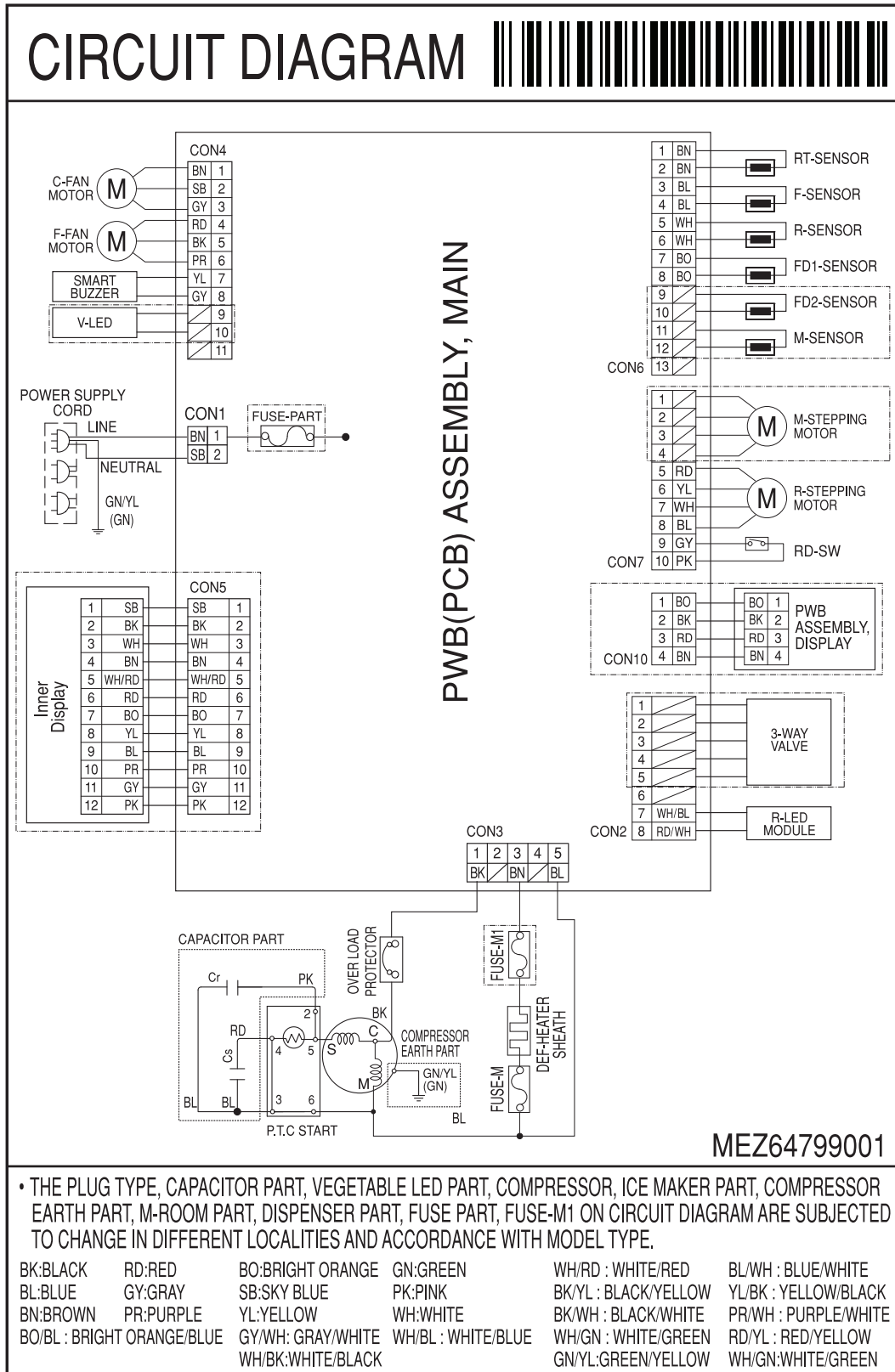

# CIRCUIT DIAGRAM

A+ HIT Model

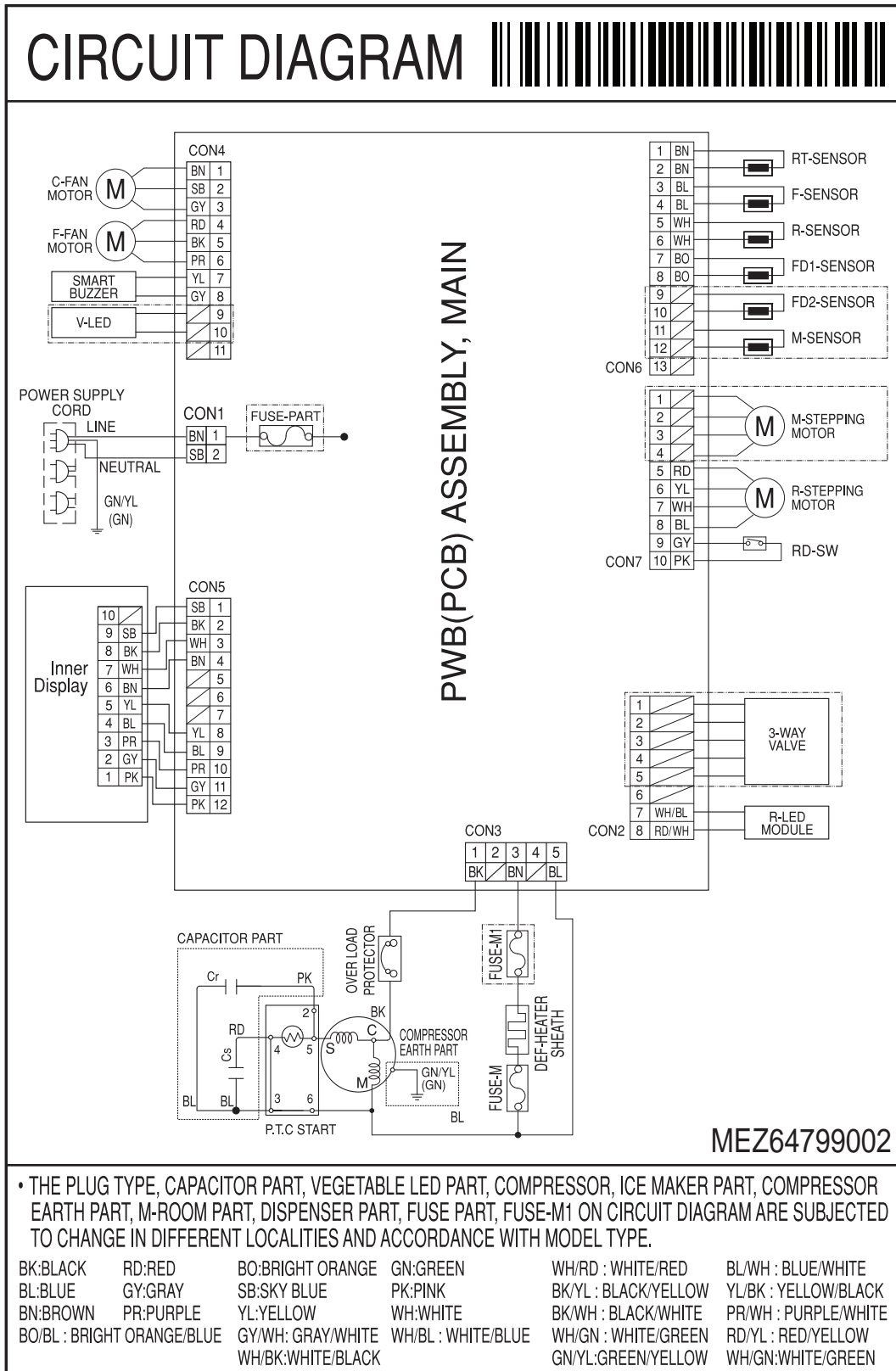



# CIRCUIT DIAGRAM

A+ + BMG

## CIRCUIT DIAGRAM



MEZ66247812

THIS REFRIGERATOR IS ELECTRONIC ACTIVATION TYPE, SO WHEN POWER PLUG IS UNPLUGGED FROM THE SOCKET, PLUG IT IN AGAIN AFTER AT LEAST 5 MINUTES. IF IT IS PLUGGED IN RIGHT AWAY, THE COMPRESSOR OPERATION MAY BE STRESSED AND CAUSE DISORDER.

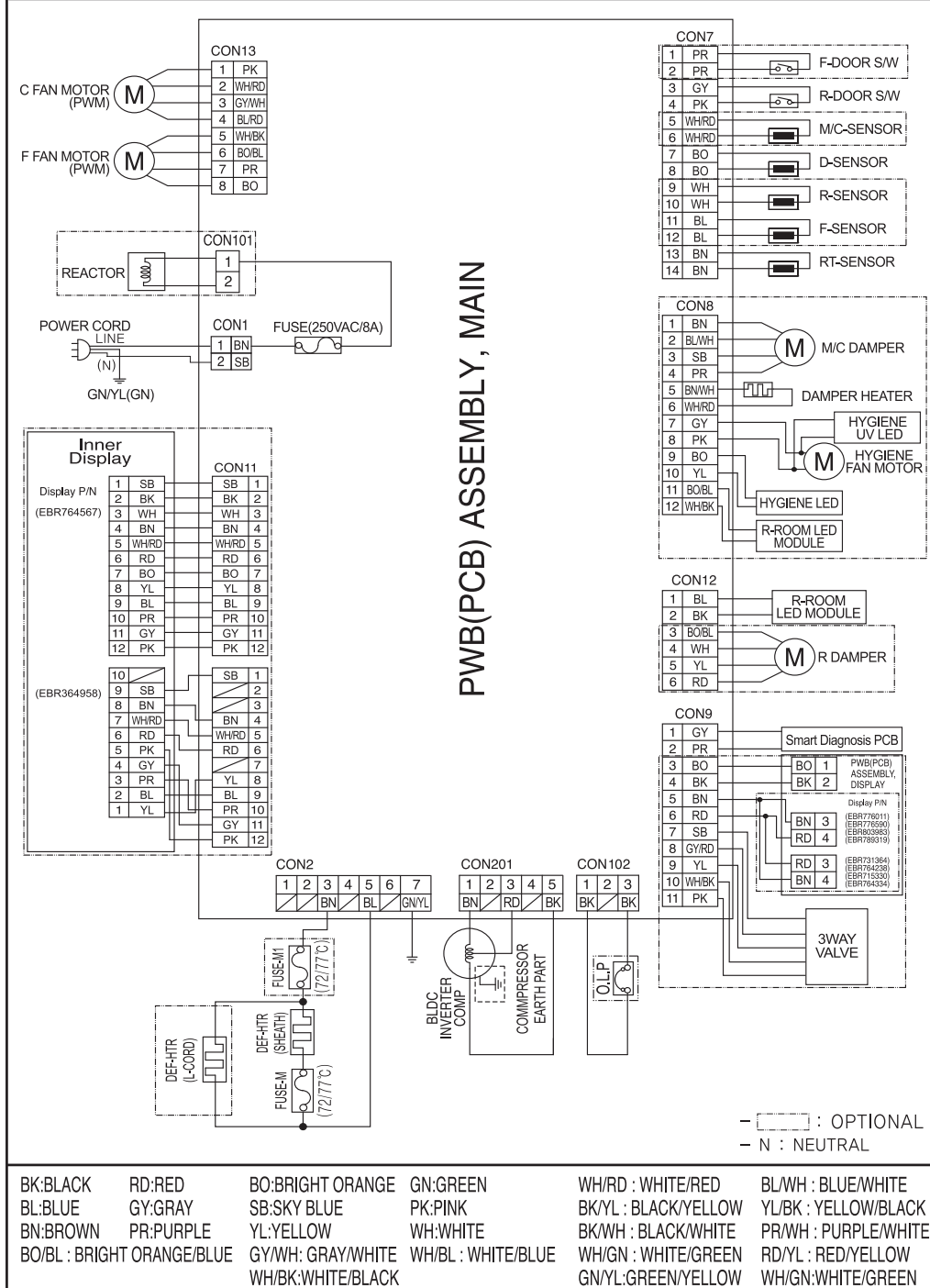

# CIRCUIT DIAGRAM

A+ BMG

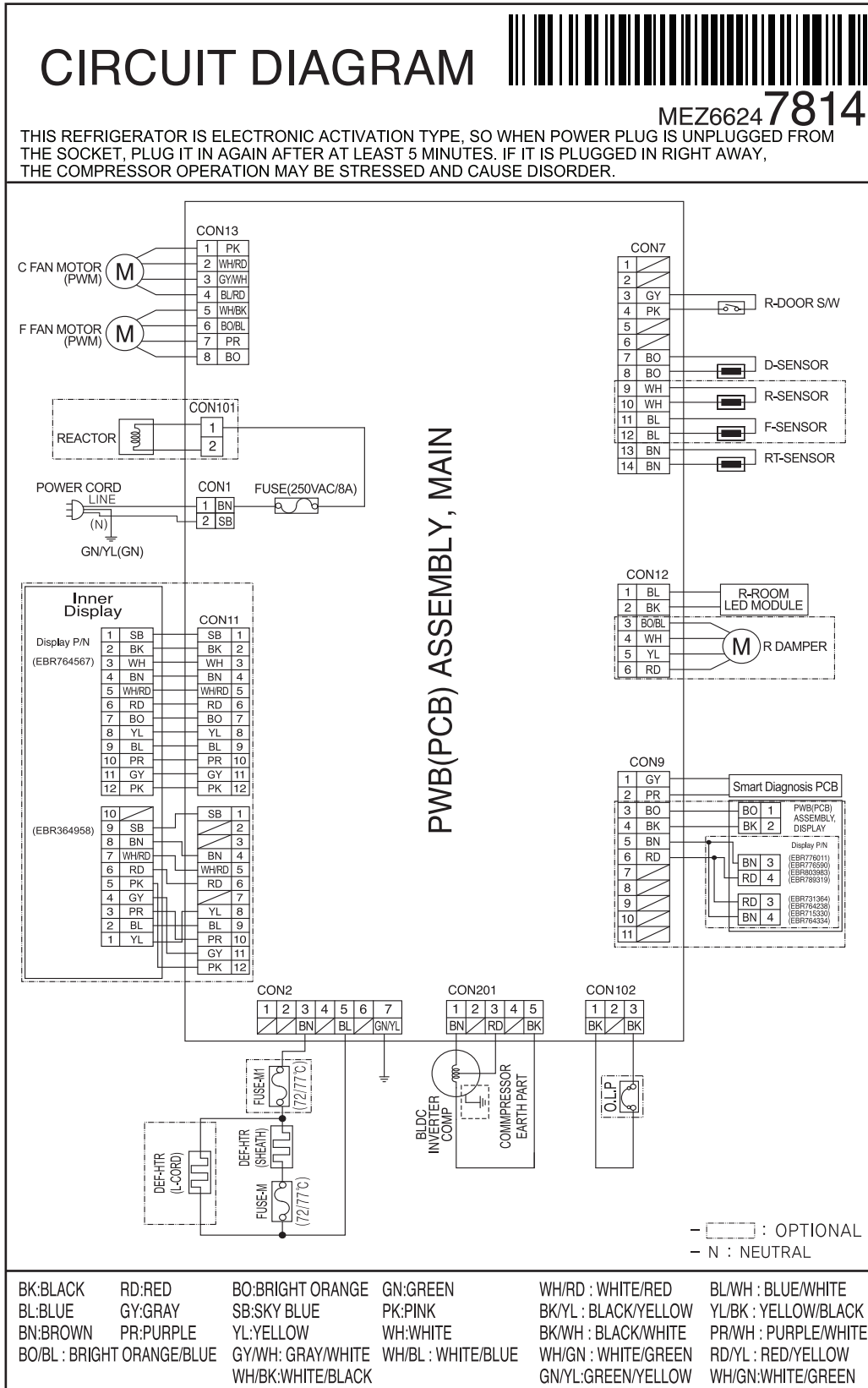

# CIRCUIT DIAGRAM

A+++ FMA

## CIRCUIT DIAGRAM



MEZ6624 7802

THIS REFRIGERATOR IS ELECTRONIC ACTIVATION TYPE, SO WHEN POWER PLUG IS UNPLUGGED FROM THE SOCKET, PLUG IT IN AGAIN AFTER AT LEAST 5 MINUTES. IF IT IS PLUGGED IN RIGHT AWAY, THE COMPRESSOR OPERATION MAY BE STRESSED AND CAUSE DISORDER.

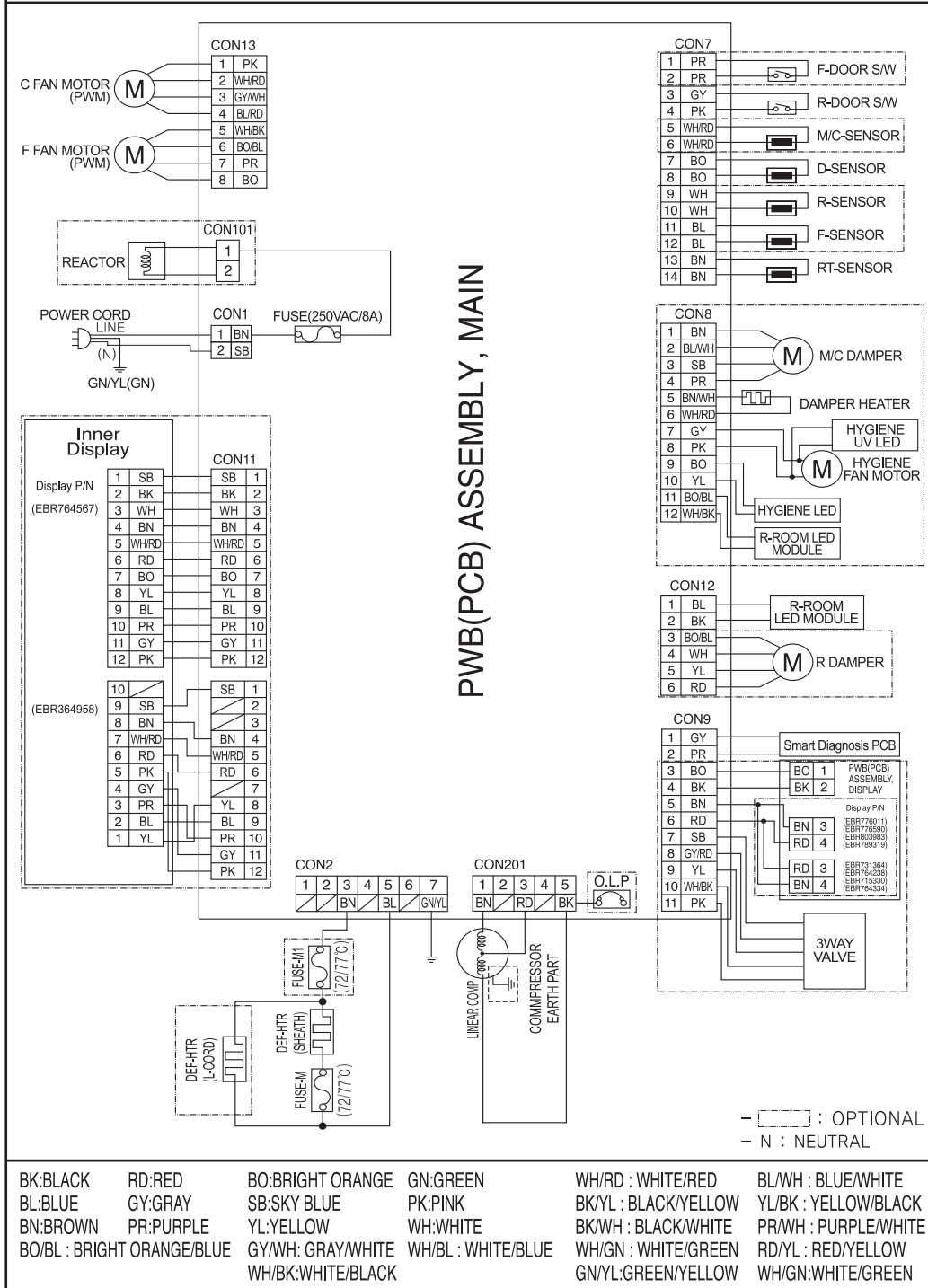

# TROUBLESHOOTING (Mechanical Part)

## 1. COMPRESSOR AND ELECTRIC COMPONENTS

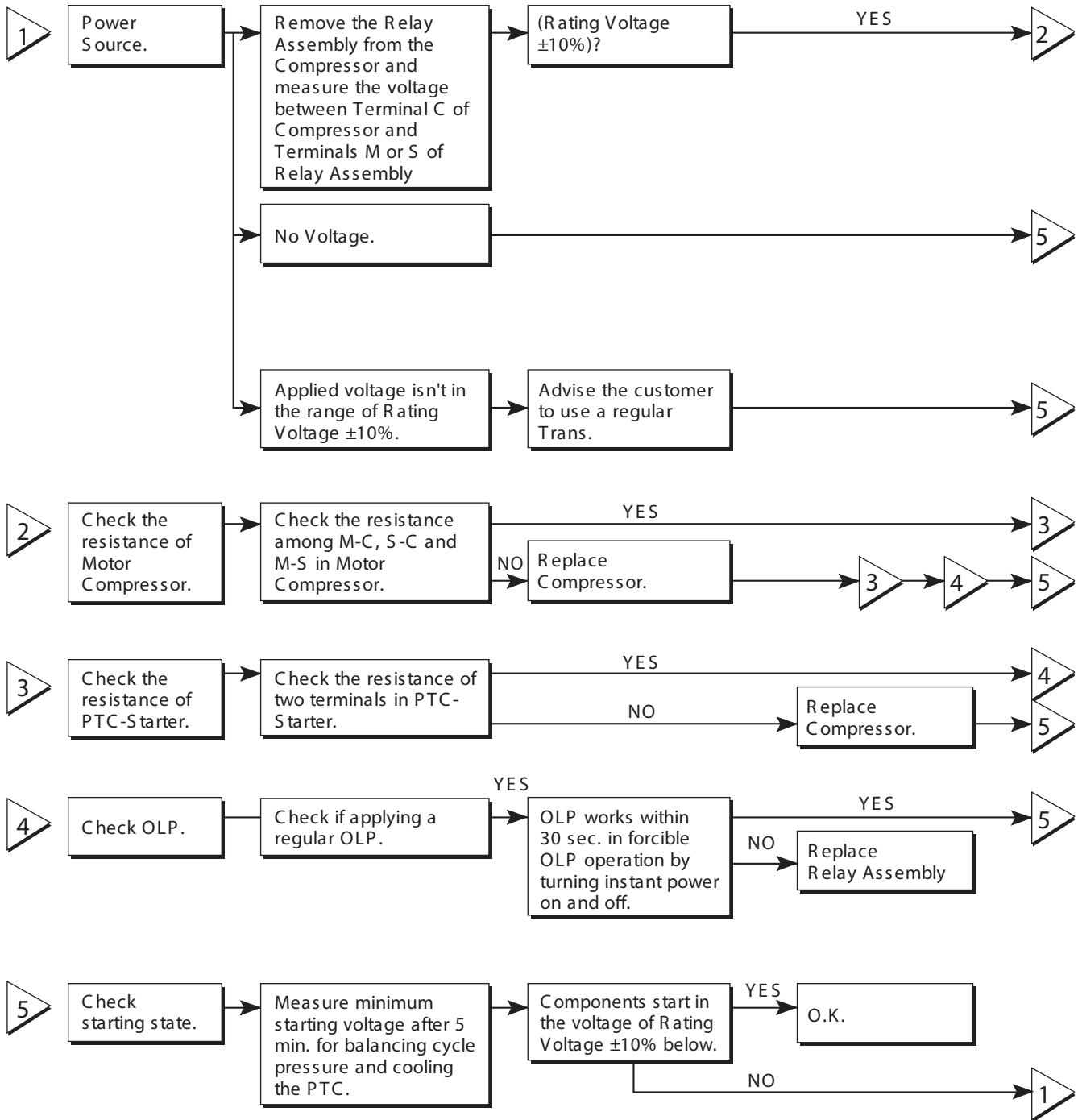

# TROUBLESHOOTING (Mechanical Part)

## 2. PTC AND OLP

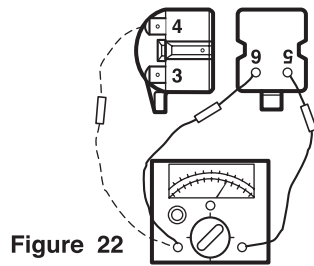
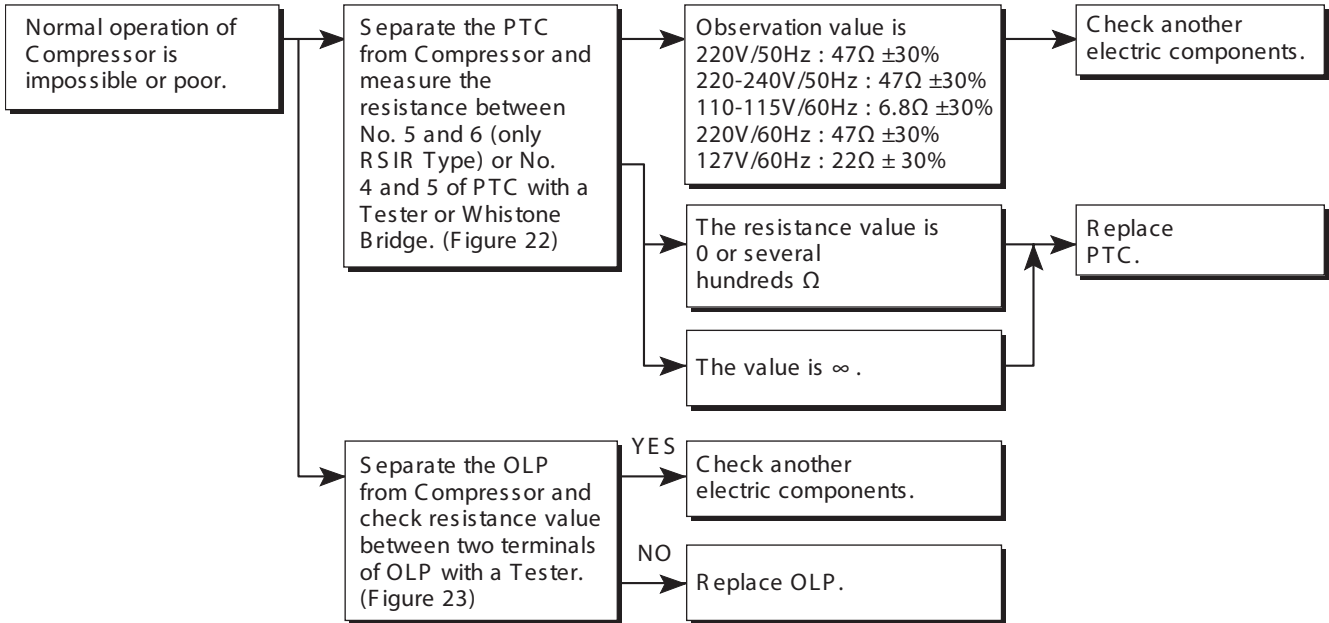

Figure 22

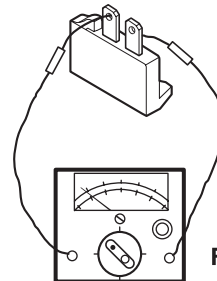
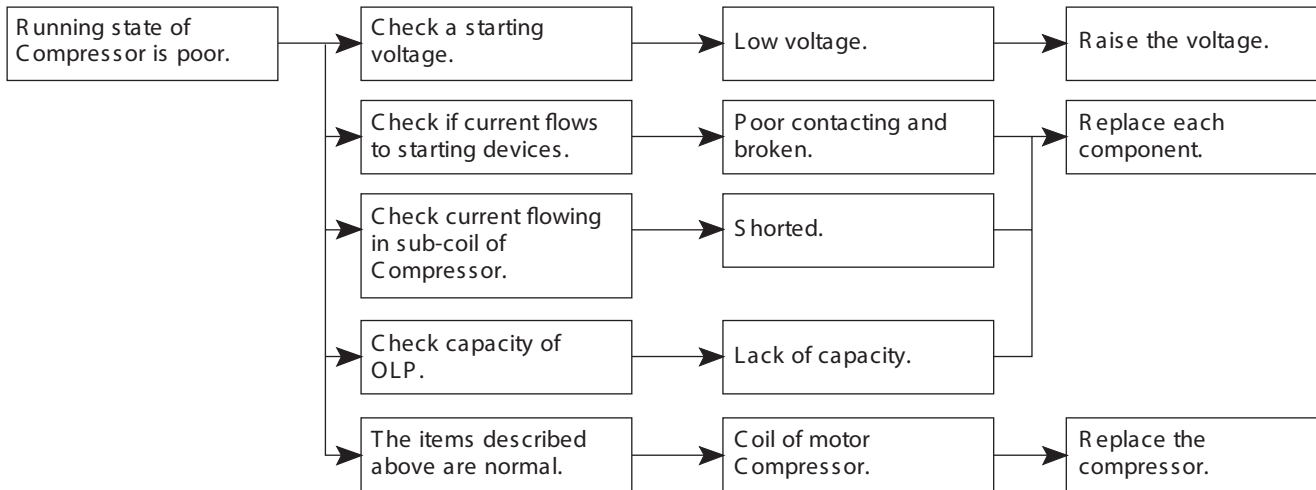
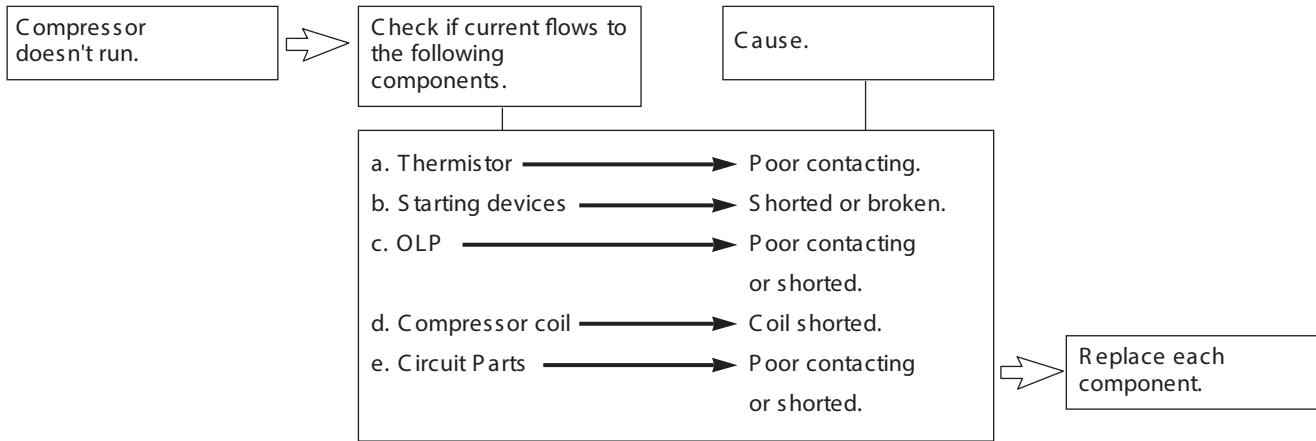

Figure 23

# TROUBLESHOOTING (Mechanical Part)

## 3. ANOTHER ELECTRIC COMPONENTS

▼ Cooling is impossible



▼ Cooling ability is poor

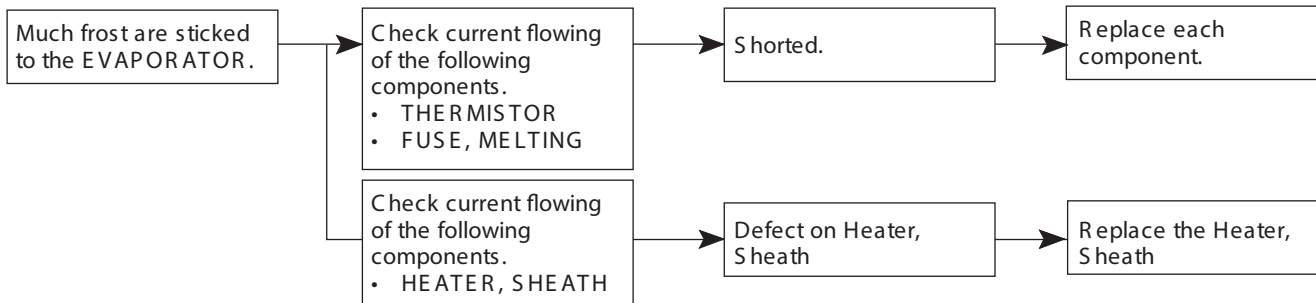
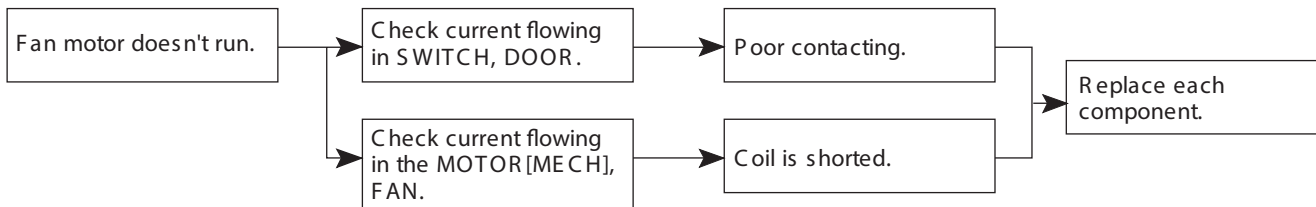

# TROUBLESHOOTING (Mechanical Part)

## 4. SERVICE DIAGNOSIS CHART

COMPLAINT	POINTS TO BE CHECKED	REMEDY
Cooling is impossible.	<ul style="list-style-type: none"> <li>Is the power cord unplugged from the outlet?</li> <li>Check if the power switch is set to OFF.</li> <li>Check if the fuse of power switch is shorted.</li> <li>Measure the voltage of power outlet.</li> </ul>	<ul style="list-style-type: none"> <li>Plug to the outlet.</li> <li>Set the switch to ON.</li> <li>Replace a regular fuse.</li> <li>If voltage is low, wire newly.</li> </ul>
Cooling ability is poor.	<ul style="list-style-type: none"> <li>Check if the set is placed close to wall.</li> <li>Check if the set is placed close to stove, gas cooker and direct rays.</li> <li>Is the ambient temperature high or the room door closed?</li> <li>Check if put in is hot.</li> <li>Did you open the door of the set too often or check if the door is closed up?</li> <li>Check if the Damper Control is set to "cold-position".</li> </ul>	<ul style="list-style-type: none"> <li>Place the set with the space of about 10cm.</li> <li>Place the set apart from these heat appliances.</li> <li>Make the ambient temperature below.</li> <li>Put in foods after cooled down.</li> <li>Don't open the door too often and close it firmly.</li> <li>Set the control to mid-position.</li> </ul>
Foods in the Refrigerator are frozen.	<ul style="list-style-type: none"> <li>Is foods placed in cooling air outlet?</li> <li>Check if the control is set to "cold-position".</li> <li>Is the ambient temperature below 5°C?</li> </ul>	<ul style="list-style-type: none"> <li>Place foods in high temperature section. (Front Part)</li> <li>Set the control to "mid-position".</li> <li>Set the control to "warm-position".</li> </ul>
Dew or ice forms in the chamber of the set.	<ul style="list-style-type: none"> <li>Is liquid food stored?</li> <li>Check if put in is hot.</li> <li>Did you open the door of the set too often or check if the door is closed up.</li> </ul>	<ul style="list-style-type: none"> <li>Seal up liquid foods with wrap.</li> <li>Put in foods after cooled down.</li> <li>Don't open the door too often and close it firmly.</li> </ul>
Dew forms in the Exterior Case.	<ul style="list-style-type: none"> <li>Check if ambient temperature and humidity of surrounding air are high.</li> <li>Is there gap in the door packed?</li> </ul>	<ul style="list-style-type: none"> <li>Wipe dew with a dry cloth. This occurrence is solved naturally in low temperature and humidity.</li> <li>Fill up the gap.</li> </ul>
Abnormal noise generates.	<ul style="list-style-type: none"> <li>Are the set positioned in a firm and even place?</li> <li>Are any unnecessary objects set in the back side of the set?</li> <li>Check if the Tray Drip is not firmly fixed.</li> <li>Check if the cover of mechanical room in below and front side is taken out.</li> </ul>	<ul style="list-style-type: none"> <li>Adjust the Adjust S crew, and position in the firm place.</li> <li>Remove the objects.</li> <li>Fix it firmly on the original position.</li> <li>Place the cover at the original position.</li> </ul>
To close the door is not handy.	<ul style="list-style-type: none"> <li>Check if the door packing is dirty with filth such as juice.</li> <li>Is the set positioned in a firm and even place?</li> <li>Is too much food putted in the set?</li> </ul>	<ul style="list-style-type: none"> <li>Clean the door packing.</li> <li>Position in the firm place and adjust the Adjust S crew.</li> <li>Keep foods not to reach the door.</li> </ul>
Ice and foods smell unpleasant.	<ul style="list-style-type: none"> <li>Check if the inside of the set is dirty.</li> <li>Did you keep smelly foods without wrapping?</li> <li>It smells of plastic.</li> </ul>	<ul style="list-style-type: none"> <li>Clean the inside of the set.</li> <li>Wrap smelly foods.</li> <li>The new products smells of plastic, but it is eliminated after 1-2 weeks.</li> </ul>

- In addition to the items described left, refer to the followings to solve the complaint.

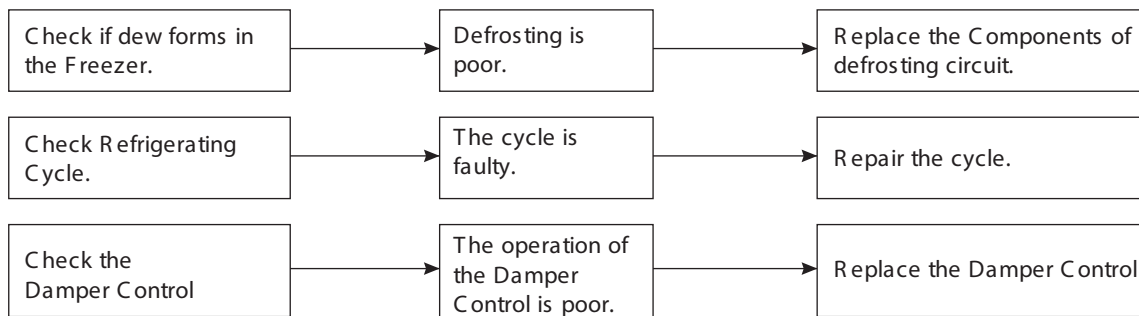

# TROUBLESHOOTING (Mechanical Part)

## 5. REFRIGERATING CYCLE

### ▼ Troubleshooting Chart

CAUSE		STATE OF THE SET	STATE OF THE EVAPORATOR	TEMPERATURE OF THE COMPRESSOR	REMARKS
LEAKAGE	PARTIAL LEAKAGE	Freezer room and Refrigerator don't cool normally.	Low flowing sound of Refrigerant is heard and frost forms in inlet only	A little high more than ambient temperature.	<ul style="list-style-type: none"> <li>A little R efrigerant discharges.</li> <li>Normal cooling is possible when injecting of R efrigerant the regular amount.</li> </ul>
	WHOLE LEAKAGE	Freezer room and Refrigerator don't cool normally.	Flowing sound of Refrigerant is not heard and frost isn't formed.	E qual to ambient temperature.	<ul style="list-style-type: none"> <li>No discharging of R efrigerant.</li> <li>Normal cooling is possible when injecting of R efrigerant the regular amount.</li> </ul>
CLOGGED BY DUST	PARTIAL CLOG	Freeze room and Refrigerator don't cool normally.	Flowing sound of Refrigerant is heard and frost forms in inlet only.	A little high more than ambient temperature.	<ul style="list-style-type: none"> <li>Normal discharging of refrigerant.</li> <li>The capillary tube is faulty.</li> </ul>
	WHOLE CLOG	Freezer room and Refrigerator don't cool.	Flowing sound of Refrigerant is not heard and frost isn't formed.	E qual to ambient temperature.	<ul style="list-style-type: none"> <li>Normal discharging of R efrigerant.</li> </ul>
MOISTURE CLOG		Cooling operation stops periodically.	Flowing sound of Refrigerant is not heard and frost melts.	Low than ambient temperature	<ul style="list-style-type: none"> <li>Cooling operation restarts when heating the inlet of capillary tube.</li> </ul>
DEFECTIVE COMPRESSION	COMP-RESSION	Freezer and Refrigerator don't cool.	Low flowing sound of Refrigerant is heard and frost forms in inlet only.	A little high than ambient temperature.	<ul style="list-style-type: none"> <li>The pressure of high pressure part in compressor is low.</li> </ul>
	NO COMP-RESSION	No compressing operation.	Flowing sound of Refrigerant is not heard and no frost.	E qual to ambient temperature.	<ul style="list-style-type: none"> <li>No pressure of high pressure part in the compressor.</li> </ul>

### ▼ Leakage Detection

- Observe discharging point of refrigerant which may be in the oil discharging part in the compressor and hole of evaporator.

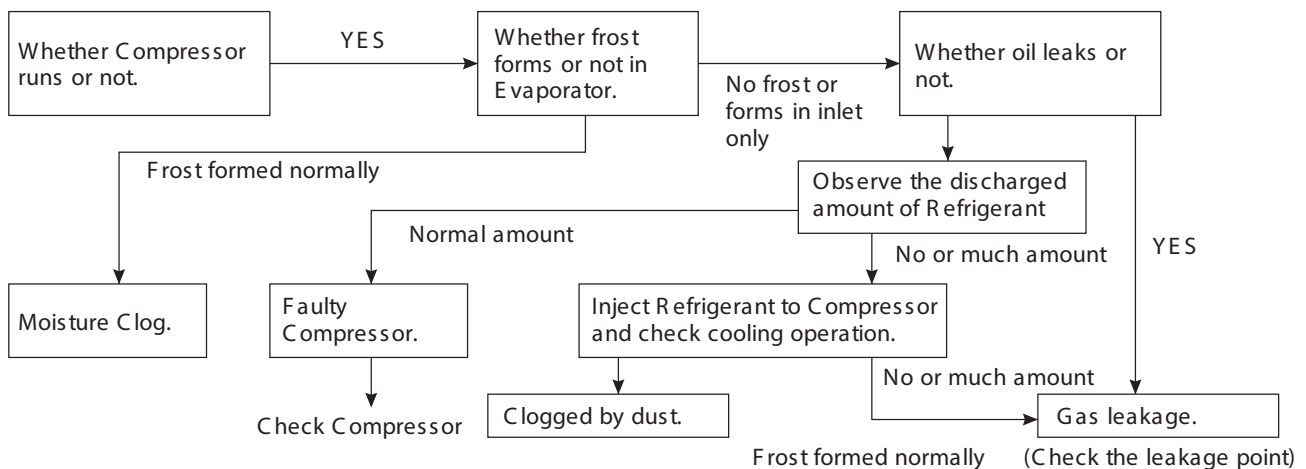



# TROUBLESHOOTING (Mechanical Part)

## ▼ General Control of Refrigerating Cycle

NO.	ITEMS	CONTENTS AND SPECIFICATIONS	REMARKS
1	WELDING ROD	(1)H 30 <ul style="list-style-type: none"> <li>• Chemical Ingredients Ag : 30%, Cu : 27%, Zn : 23%, Cd : 20%</li> <li>Brazing Temperature : 710~840°C</li> </ul> (2)Bcup-2 <ul style="list-style-type: none"> <li>• Chemical Ingredients Cu : About 93%</li> <li>P : 6.8~7.5%</li> <li>The rest : within 0.2%</li> <li>• Brazing Temperature : 735~840°C</li> </ul>	<ul style="list-style-type: none"> <li>• Recommend H34 containing 34% Ag in the Service Center.</li> </ul>
2	FLUX	<ul style="list-style-type: none"> <li>• Ingredients and how to make Borax 30%</li> <li>Borax 35%</li> <li>Fluoridation kalium : 35%</li> <li>Water : 4%</li> <li>Mix the above ingredients and boil until they are transformed into liquid.</li> </ul>	<ul style="list-style-type: none"> <li>• Make amount for only day. Holding period : 1 day</li> <li>• Close the cover of container to prevent dust putting in the FLUX.</li> <li>• Keep it in a stainless steel container.</li> </ul>
3	LOKRING (Figure 23, 24)	(1)Both of the tube is inserted up to the stop. (2)Both of the LOKRING is pushed up to the stop (3)The bending point is not too close to the joint ending. (4)During the assembly it is important that both ends remain completely within the joint.	<ul style="list-style-type: none"> <li>• For a hermetically sealed metal/metal connection, the tube ends have to be clean.</li> <li>• LOKPREP is distributed all of out-surface of the tube ends.</li> </ul>
4	DRIER ASM	(1)Assemble the drier within 30min. after unpacking. (2)Keep the unpacked drier at the temperature of 80~100°C.	<ul style="list-style-type: none"> <li>• Don't keep the drier in a outdoors because humidity damages to it.</li> </ul>
5	VACUUM	(1)When measuring with pirant Vacuum gauge the charging M/C, vacuum degree is within 1 Torr. (2)If the vacuum degree of the cycle inside is 10 Torr. below for low pressure and 20 Torr. for high pressure, it says no vacuum leakage state. (3)Vacuum degree of vacuum pump must be, 0.05 Torr. below after 5 min. (4)Vacuum degree must be same to the value described item above for more than 20 min.	<ul style="list-style-type: none"> <li>• Apply M/C Vacuum Gauge without fail.</li> <li>• Perform vacuum operation until a proper vacuum degree is built up.</li> <li>• If a proper vacuum degree isn't built up, check the leakage from the Cycle Pipe line part and Quick Coupler Connecting part.</li> </ul>
6	DRY AND AIR NITROGEN GAS	(1)The pressure of dry air must be more han 12~16kg/cm <sup>2</sup> (2)Temperature must be more than -20~-70°C. (3)Keep the pressure at 12~6kg/cm <sup>2</sup> also when substituting dry air for Nitrogen Gas.	
7	NIPPLE AND COUPLER	(1)Check if gas leaks with soapy water. (2)Replace Quick Coupler in case of leakage.	<ul style="list-style-type: none"> <li>• Check if gas leaks from joint of the Coupler.</li> </ul>
8	PIPE	<ul style="list-style-type: none"> <li>• Put all Joint Pipes in a clean box and cover tightly with the lid so that dust or humidity is not inserted.</li> </ul>	

# TROUBLESHOOTING (Mechanical Part)

---

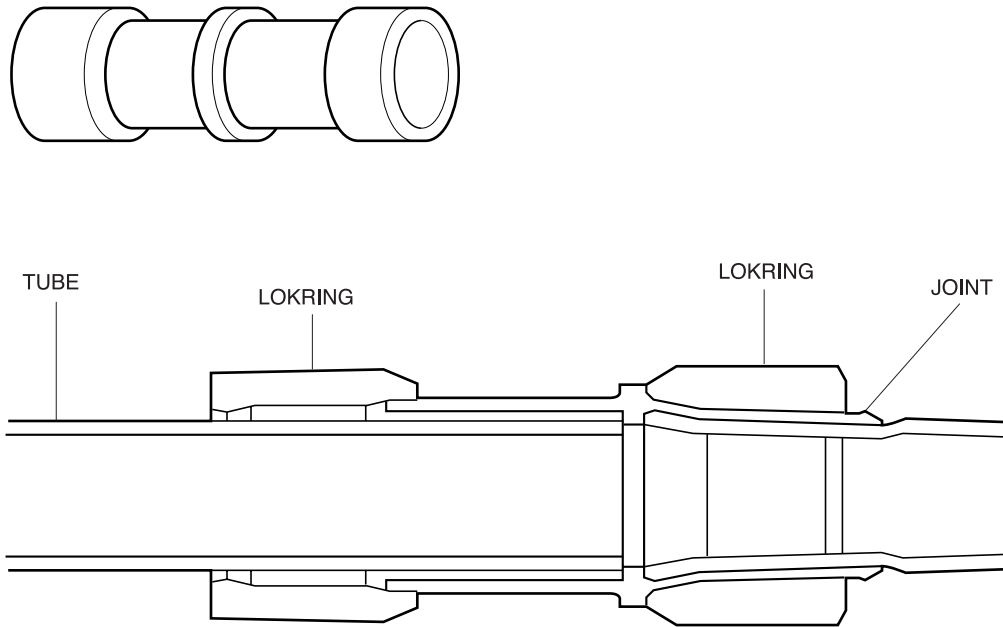

Figure 23. LOKRING

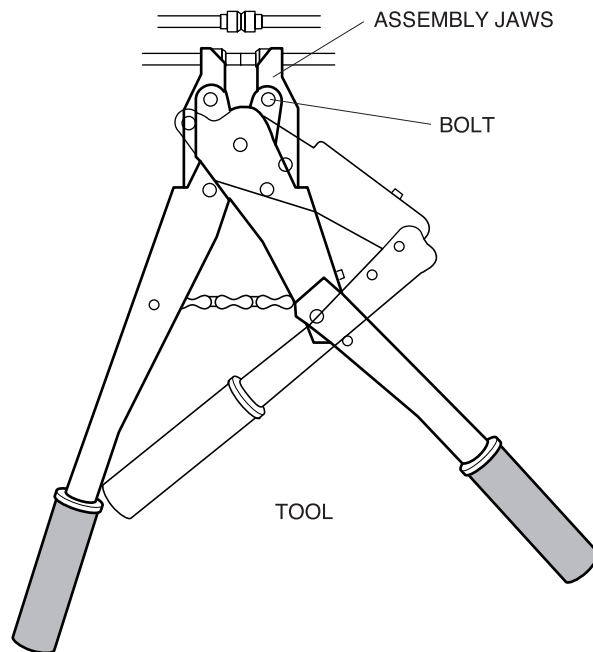

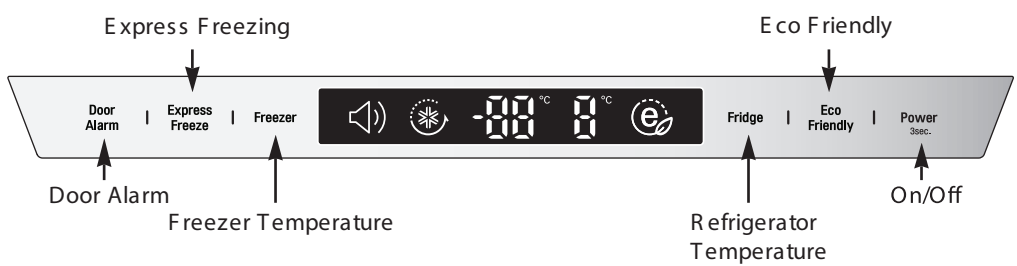

Figure 24. LOKRING TOOL

# MICOM FUNCTION & PCB CIRCUIT EXPLANATION

## 1. FUNCTION EXPOSITION

### 1) FUNCTION

(1) When the appliance is plugged in, it is set to 3°C for the Refrigerator and -20°C for the Freezer. You can adjust the Refrigerator and the Freezer control temperature by pressing the FRZ. Temp button or REF. Temp button.

Model Variety	ITEM
Interior Display LED 88	<p>88 LED Tact *Color : Yellow Green</p>  <p>Express Freezing</p> <p>Eco Friendly</p> <p>Door Alarm</p> <p>Express Freeze</p> <p>Freezer</p> <p>Freezer Temperature</p> <p>Fridge</p> <p>Eco Friendly</p> <p>Power Ssec.</p> <p>Refrigerator Temperature</p> <p>On/Off</p>
Exterior Display	<p>88 LED Tact *Color : Amber</p>  <p>Freezer Temperature</p> <p>Express Freezing</p> <p>Door Alarm Display Lock</p> <p>Refrigerator Temperature</p> <p>Eco Friendly</p> <p>On/Off</p>
Interior Display LED Bar	<p>Inner Bar LED Tact *Color : Yellow Green</p>  <p>Express Freezing</p> <p>Eco Friendly</p> <p>Express Freeze</p> <p>Freezer</p> <p>Freezer Temperature</p> <p>Total No Frost</p> <p>Fridge</p> <p>Eco Friendly</p> <p>Refrigerator Temperature</p>

- Display Power saving Mode

The display is always OFF without Lock Icon, until door is opened.

# MICOM FUNCTION & PCB CIRCUIT EXPLANATION

## 2) Express Frz.

- Please select this function for prompt freezing.
- This function is used when you want to freeze the foods quickly. Press the Express Frz. button once, and then the quick freeze operation starts with the lamp on.
- The Express Frz. operation takes about 24 hours. When its operation ends, it automatically returns to the previous temperature setting. If you want to stop the quick freeze operation, press the Express Frz. button once more, the lamp goes out, and the Express Frz. operation stops and the refrigerator returns to the previous temperature setting.

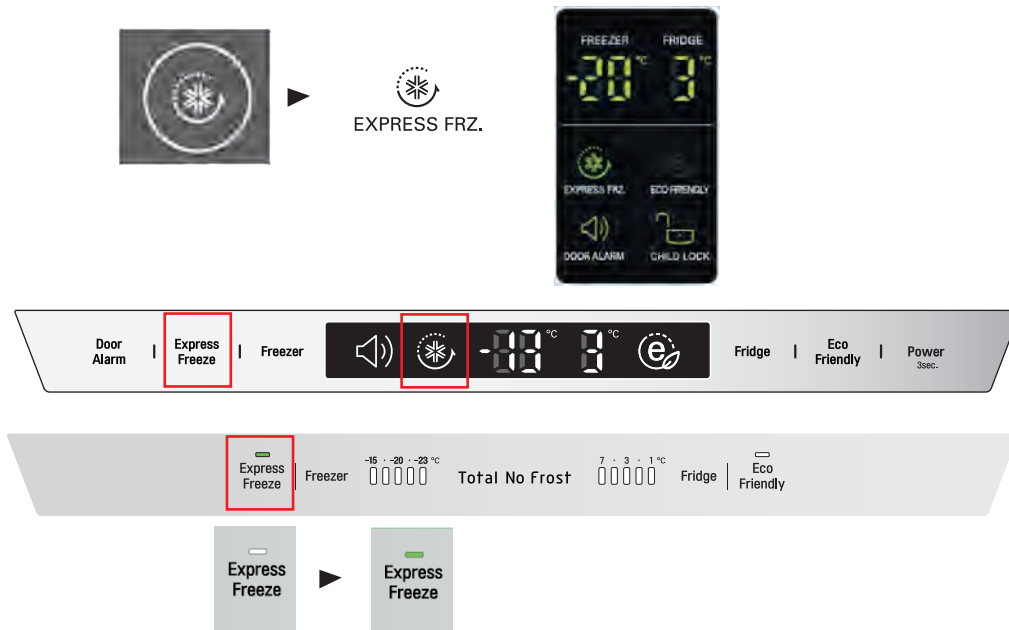

## 3) Eco Friendly

This function makes the fridge-freezer work in a power saving mode which is useful for when you are away on holiday, by reducing energy consumption.

Pressing 'ECO FRIENDLY' starts operation with lamp on and pressing it again stops the operation.

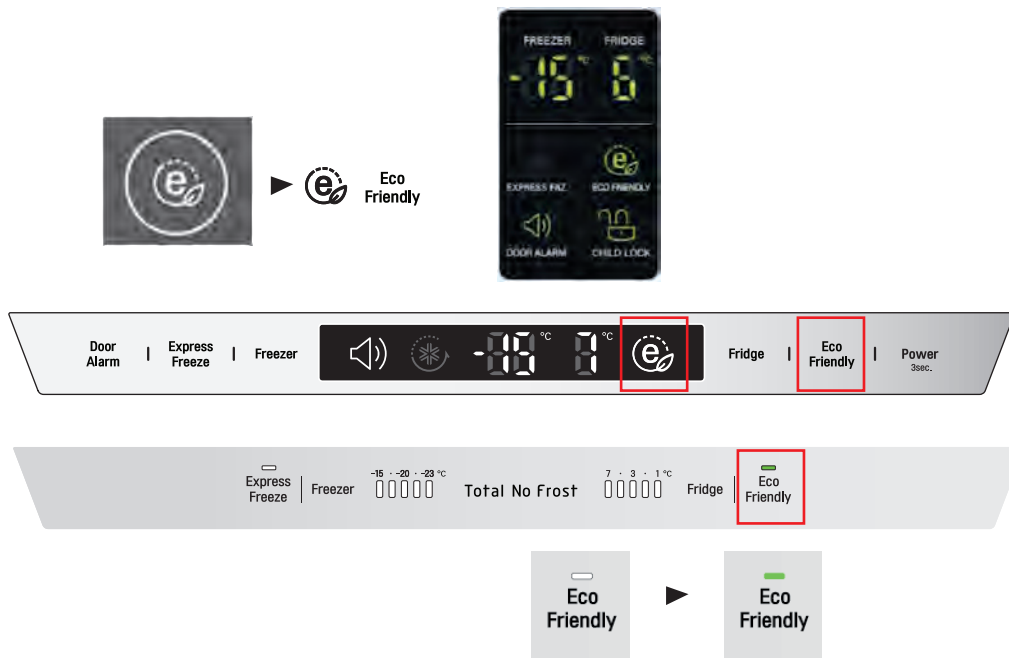

NOTE :

When the Eco Friendly mode is "ON", the other buttons will not operate. When you come back from Eco Friendly, press the Eco Friendly mode off so that other buttons work and the refrigerator returns to previous temperature setting.

# MICOM FUNCTION & PCB CIRCUIT EXPLANATION

## 4) Lock

### For Exterior Display

- Pressing this button stops operation of other buttons.
- "Locking" or "Un-Locking" is repeated whenever pressing the LOCK button.  
(For "Locking" press the "LOCK" button for 3 sec. For "Un-Locking" press the "LOCK" button for 3 sec.)
- When 'LOCK' is activated, pressing the other buttons would not work.

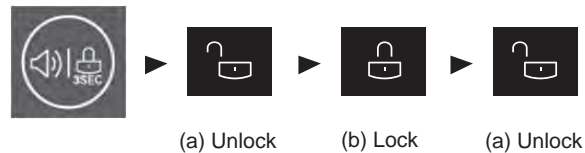

## 5) Power On/Off

Pressing this button refrigerator power is ON or OFF.

- ON or OFF is repeated whenever pressing the ON/OFF button.  
(For "OFF" press the "ON/OFF" button for 3 sec. For "ON" press the "ON/OFF" button for 1 sec.)



## 6) Door Alarm Buzzer Mute Mode

- Press ALARM/LOCK to turn the buzzer on or off.

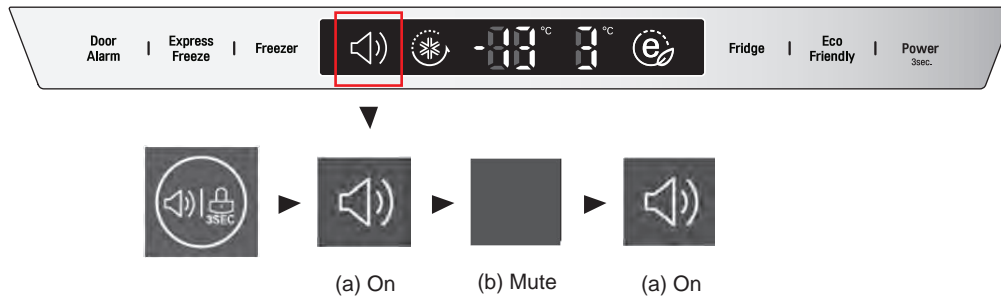

# MICOM FUNCTION & PCB CIRCUIT EXPLANATION

## 7) Exhibition(Demo) Mode

- Demo mode is available for displaying the refrigerator in a sales setting or similar condition.
- It allows the display, dispenser, and lights to operate without running the compressor and fan.
- To apply the DEMO mode, open the door and press and hold the REFRIGERATOR and EXPRESS FRZ. buttons simultaneously for 5 second.
- To exit the DEMO mode and return to normal operation, press and hold the REFRIGERATOR and EXPRESS FRZ. for 5 second.



<BETTER-88 LED>

# MICOM Error Code

► A+++ , A++ , A+

Show error mode when push 'Freezer temp' and 'express Freezing' button, simultaneously for 1 sec. (All on Mode)





NO	Item	Error Code		Contents	Remarks
		Freezer			
		Interior	Exterior		
1	Normal	temperature.		-	Display S switch is normal
2	Failure of Freezer Sensor	FSE	FS	Cut or short circuit wire	Check the connection of each sensor
3	Failure of Refrigerator Sensor	rSE	rS	Cut or short circuit wire	
4	Failure of Freezer Defrost Sensor	dS F		Cut or short circuit wire	
5	Failure of outdoor Sensor	rt E	rt	Cut or short circuit wire	
6	Poor of Freezer Defrost	dH F		120min later After starting defrost. If sensor doesn't be over 8°C.	Snapping of defrost heater and Temperature fuse, Poor of Heater relay operation, Drain is blocked.
7	Failure of BLDC FAN Motor	FFE	FF	Feedback signal was not detected within 65sec from BLDC Fan motor	BLDC Motor wire disconnection, Drive IC and TR Error
8	Failure of BLDC C-FAN Motor	CFE	CFE		
9	Cycle Error	FU E		The difference of D-Sensor temperature isn't under the 3.5deg within 10min, after LQC mode started	Check the Compressor Cooling power
10	Communication Error	CO	-	If there is no signal for communication between main and display PCB.	Lead wire short between main and Display PCB, transmission TR and receiving part.

# MICOM Error Code

► A++ HIT, A+ HIT

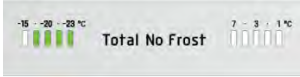
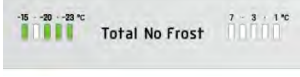
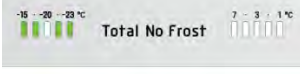
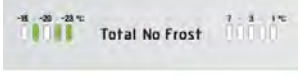
Show error mode when push 'Freezer temp' and 'express Freezing' button, simultaneously for 1 sec. (All on Mode)

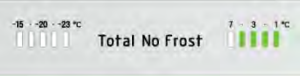
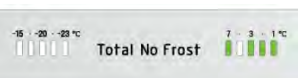
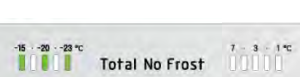
NO	Item	Error Code	Contents	Remarks
		Freezer		
1	Normal	temperature.	-	Display Switch is normal
2	Failure of Freezer Sensor		Cut or short circuit wire	Check the connection of each sensor
3	Failure of Refrigerator Sensor		Cut or short circuit wire	
4	Failure of Freezer Defrost Sensor		Cut or short circuit wire	
5	Failure of outdoor Sensor		Cut or short circuit wire	
6	Poor of Freezer Defrost Heater		120min later After starting defrost. If sensor doesn't be over 8°C.	
7	Failure of BLDC F-FAN Motor		Feedback signal was not detected within 65sec from BLDC Fac motor	BLDC Motor wire disconnection, Drive IC and TR Error
8	Failure of BLDC C-FAN			
9	Cycle Error		The difference of D-Sensore temperature isn't under the 3.5deg within 10min, after LQC mode started	Check the Compressor Cooling power



# MICOM Error Code

## 1. Error Code Summary



**WARNING**

When you check the Resistance values, be sure to turn off the power.  
And wait for the voltage-discharge sufficiently.

### (1) FAILURE DIAGNOISS FUNCTION

○ : Normality

NO	Item	Load control				
		COMP	C-FAN	F-FAN	Defrost Heater	R Damper
1	Normal	○	○	○	○	○
2	Failure of Freezer Sensor	15M ON / 15M OFF	15M ON / 15M OFF	○	○	○
3	Failure of Fridge Sensor	○	○	○	○	10min OPEN/ 15mon CLOSE
4	Failure of Freezer Defrost Sensor	○	○	○	No Defrost (return immediately)	○
5	Failure of outdoor Sensor	○	○	○	○	○
6	Poor of Freezer Defrost	○	○	○	○	○
7	Failure of BLDC F-FAN Motor	○	○	Periodic ON/OFF	○	○
8	Failure of BLDC C-FAN Motor	○	Periodic ON/OFF	○	○	○
9	Cycle Error	○	○	○	○	○
10	Communication Error (External Display only)	○	○	○	○	○

# PCB Picture

## 1. Main PCB

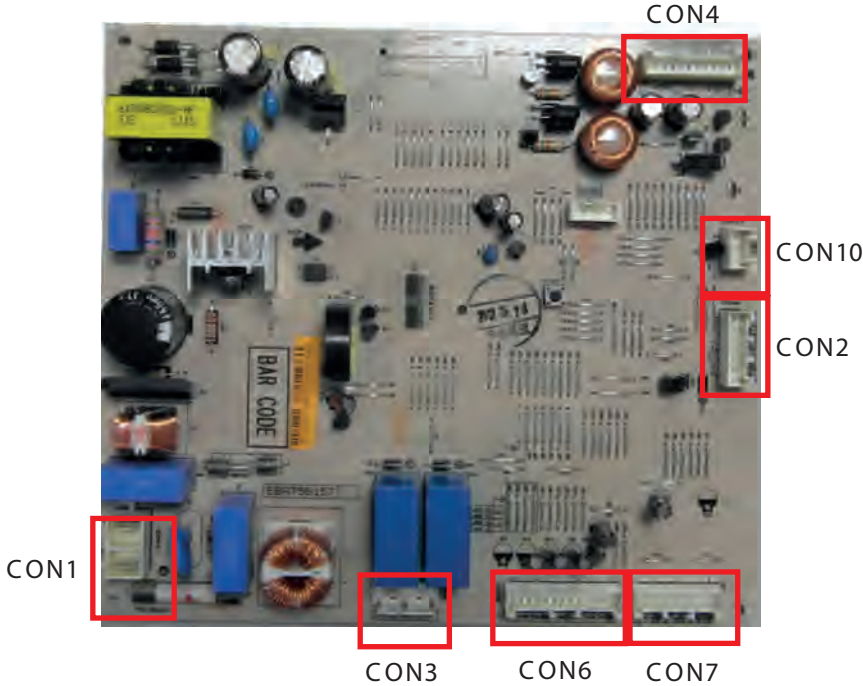
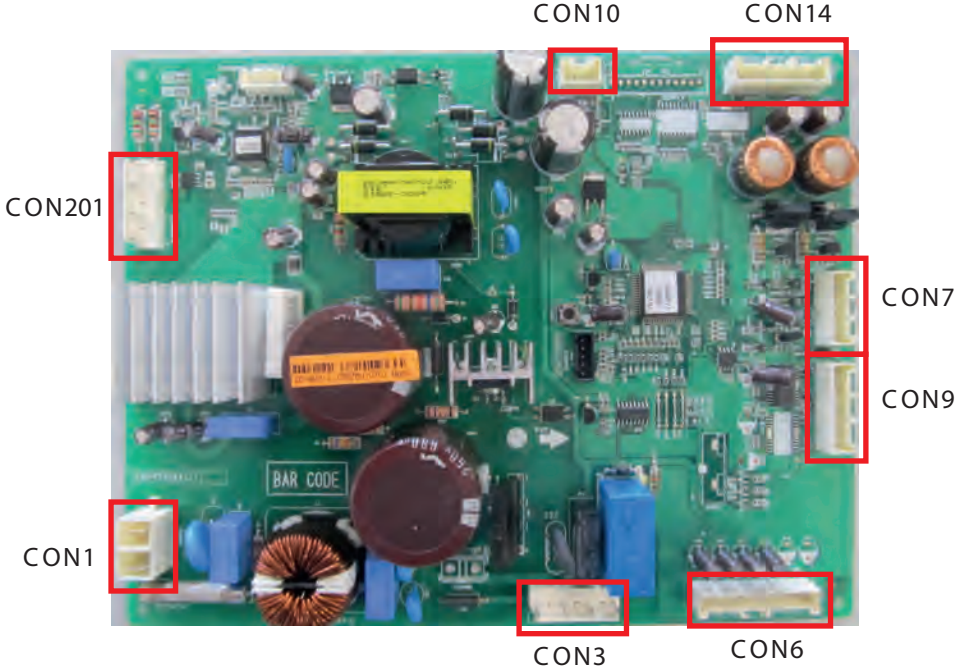
P/No & MFG	Picture
<p>EBR75815702 EBR75815706 EBR75815709 EBR75815711</p>	 <p>CON1</p> <p>CON2</p> <p>CON3</p> <p>CON4</p> <p>CON6</p> <p>CON7</p> <p>CON10</p>
<p>EBR78910701 EBR78910702 EBR78910703 EBR78910704</p>	 <p>CON1</p> <p>CON3</p> <p>CON6</p> <p>CON7</p> <p>CON9</p> <p>CON10</p> <p>CON14</p> <p>CON201</p>

# PCB Picture

## 1. Main PCB

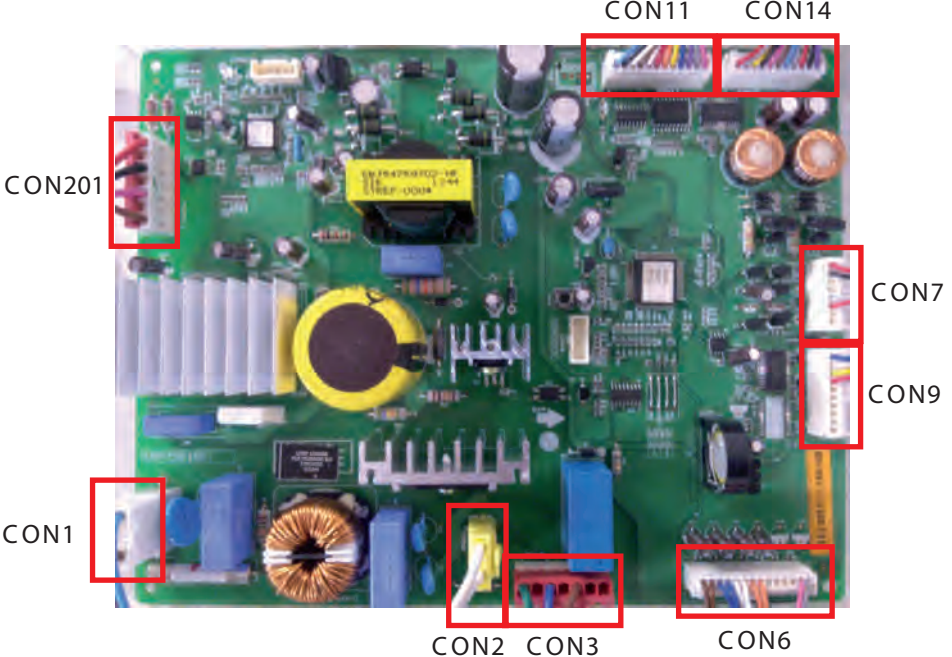
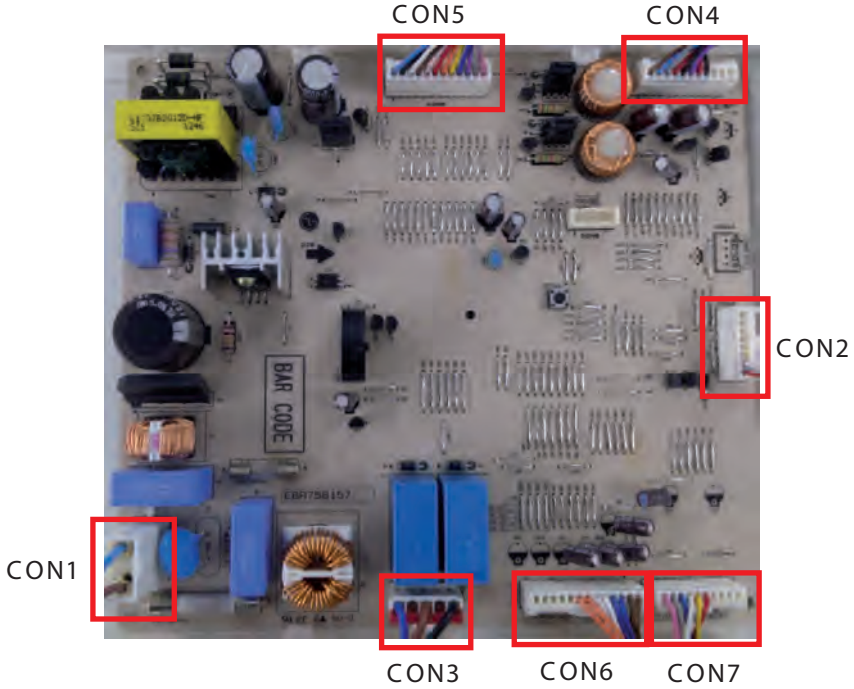
P/No & MFG	Picture
<p>EBR75815601                      EBR75815602                      EBR75815607                      EBR75815608                      EBR75815611                      EBR75815618                      EBR75815620</p>	 <p>CON11 CON14</p> <p>CON201</p> <p>CON7</p> <p>CON9</p> <p>CON1</p> <p>CON2 CON3 CON6</p>
<p>EBR75815701                      EBR75815705                      EBR75815708                      EBR75815710</p>	 <p>CON5 CON4</p> <p>CON2</p> <p>CON1</p> <p>CON3 CON6 CON7</p>

# PCB Picture

## 1. Main PCB

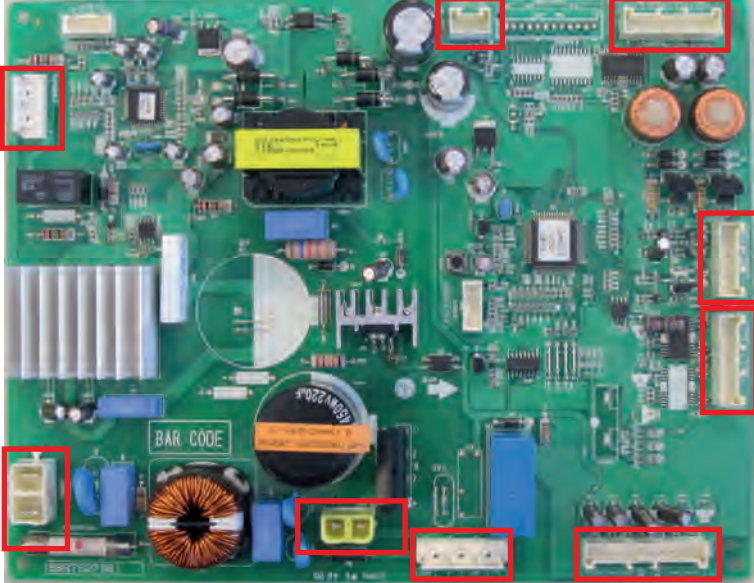
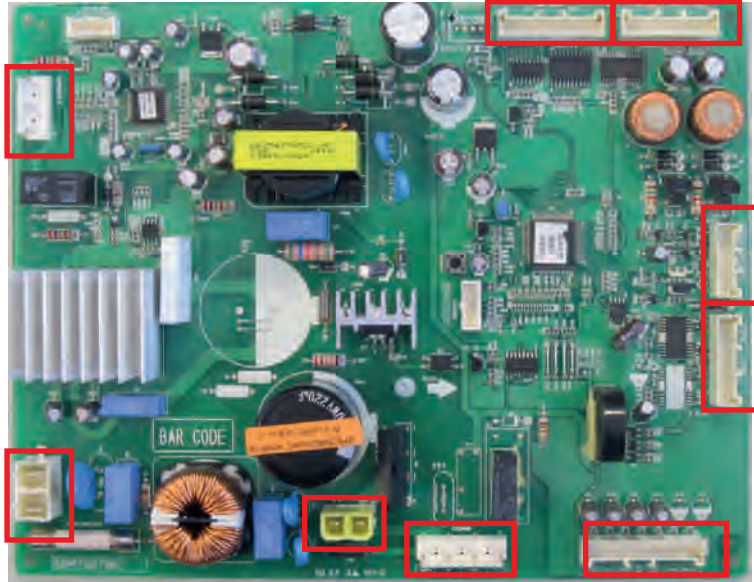
P/No & MFG	Picture
<p>EBR79279801 EBR79279803 EBR79279805 EBR79279807</p>	 <p>CON10 CON14</p> <p>CON201</p> <p>CON7</p> <p>CON9</p> <p>CON1</p> <p>CON2 CON3 CON6</p>
<p>EBR79279802 EBR79279804 EBR79279806</p>	 <p>CON11 CON14</p> <p>CON201</p> <p>CON7</p> <p>CON9</p> <p>CON1</p> <p>CON2 CON3 CON6</p>

# PCB Picture

## 1. Main PCB

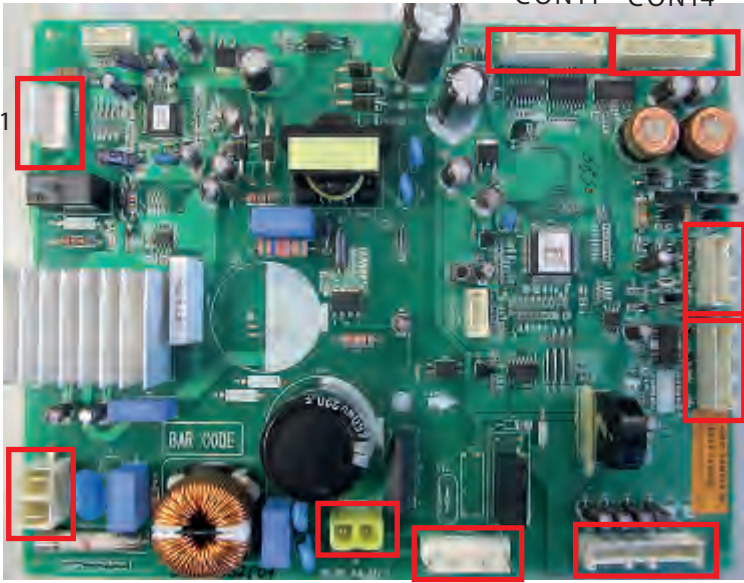
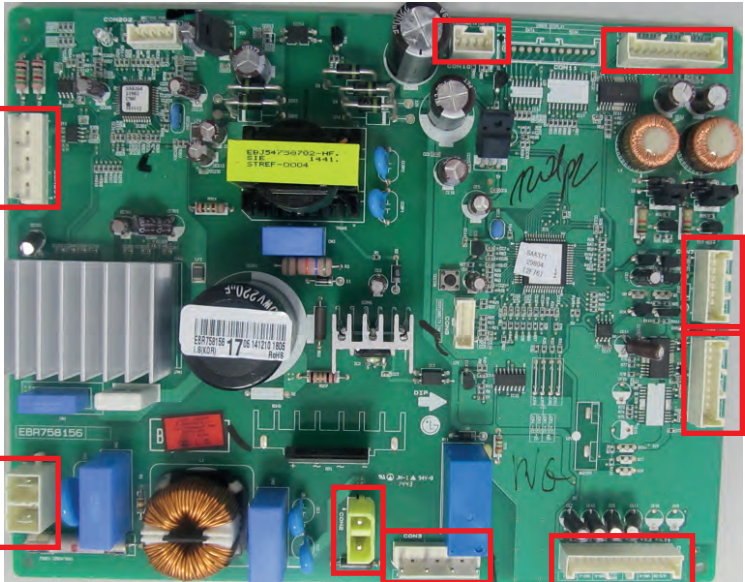
P/No & MFG	Picture
<p>EBR79832601                      EBR79832602                      EBR79832603                      EBR79832604</p>	 <p>CON11 CON14</p> <p>CON201</p> <p>CON1</p> <p>CON2 CON3 CON6</p> <p>CON7 CON9</p>
<p>EBR75815604                      EBR75815605                      EBR75815609                      EBR75815610                      EBR75815616                      EBR75815617                      EBR75815619</p>	 <p>CON10 CON14</p> <p>CON201</p> <p>CON1</p> <p>CON2 CON3 CON6</p> <p>CON7 CON9</p>

# PCB Picture

## 1. Main PCB

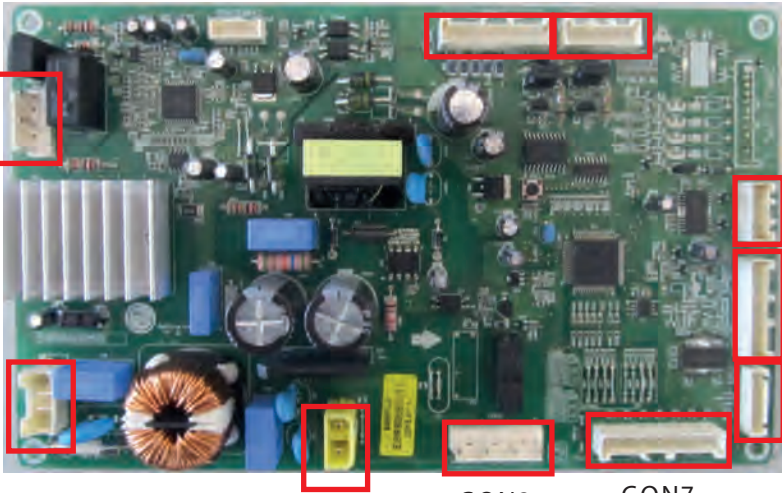
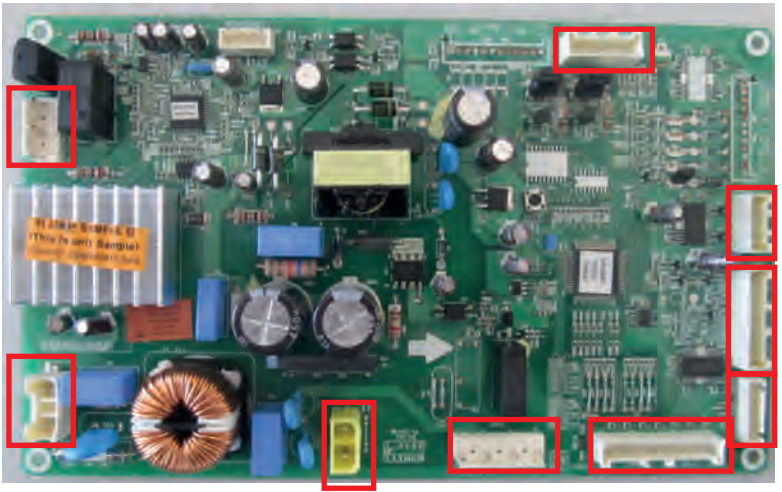
P/No & MFG	Picture
<p>EBR80085*11 EBR80085*13</p>	 <p>CON11 CON13</p> <p>CON201</p> <p>CON1</p> <p>CON101</p> <p>CON2</p> <p>CON7</p> <p>CON12</p> <p>CON9</p> <p>CON6</p>
<p>EBR80085*12</p>	 <p>CON13</p> <p>CON201</p> <p>CON1</p> <p>CON101</p> <p>CON2</p> <p>CON7</p> <p>CON12</p> <p>CON9</p> <p>CON6</p>

# PCB Picture

## 1. Main PCB

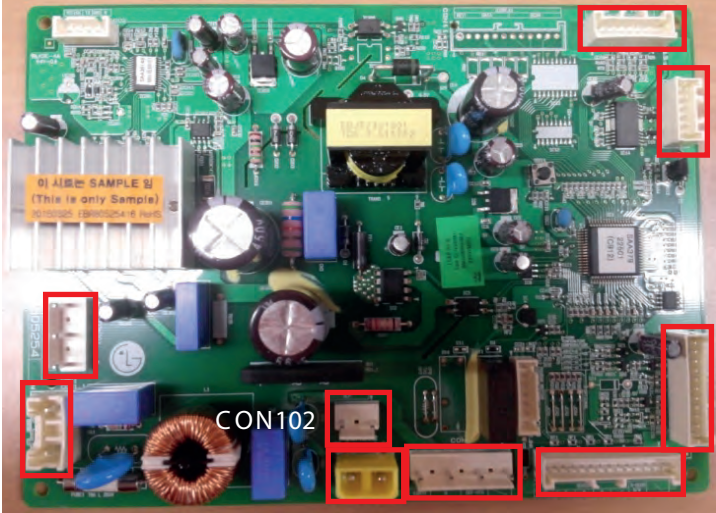
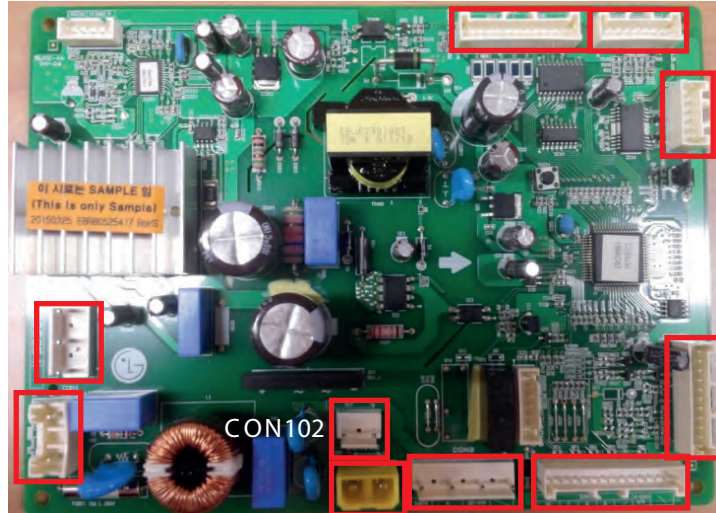
P/No & MFG	Picture
EBR80525416	 <p>CON13</p> <p>CON12</p> <p>CON201</p> <p>CON1</p> <p>CON102</p> <p>CON9</p> <p>CON101 CON2 CON7</p>
EBR80525417 EBR80525418	 <p>CON11 CON13</p> <p>CON12</p> <p>CON201</p> <p>CON1</p> <p>CON102</p> <p>CON9</p> <p>CON101 CON2 CON7</p>

# PCB Picture

## 2. Display PCB

P/No	Picture
EBR764567	
ACQ838523	
EBR364958	



# Troubleshooting With Error Display

## 1. Freezer Sensor Error (FS E)



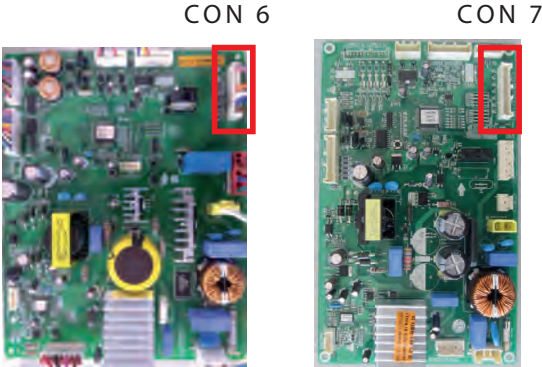
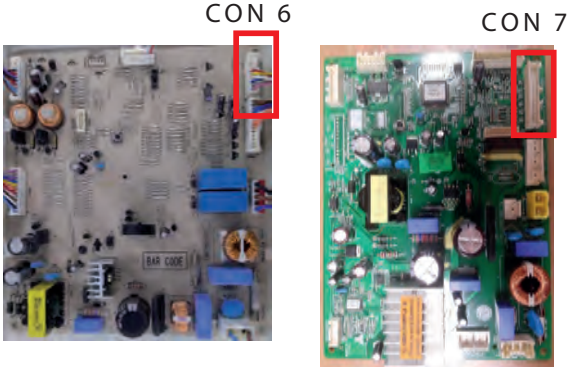



Step No	Check Item	Result & SVC Action																												
1	Check for a loose connection.																													
2	<ul style="list-style-type: none"> <li>Linear A++, A +++ Check the <u>Pin11(1) to Pin12(2) of CON6.</u> Check the <u>Pin11(1) to Pin12(2) of CON7.</u></li> </ul>  <ul style="list-style-type: none"> <li>A ++, A+ Check the <u>Pin3(1) to Pin4(2) of CON6.</u> Check the <u>Pin11(1) to Pin12(2) of CON7.</u></li> </ul> 	<table border="1"> <thead> <tr> <th colspan="2">Result</th> <th>SVC Action</th> </tr> </thead> <tbody> <tr> <td>0Ω</td> <td>Short</td> <td>Change the sensor</td> </tr> <tr> <td>OFF</td> <td>Open</td> <td>Replace the refrigerator</td> </tr> <tr> <td>Other</td> <td>Normal</td> <td>Check the Temp and resistance (Table-1)</td> </tr> </tbody> </table> <p>&lt;Temperature table-1&gt;</p> <table border="1"> <thead> <tr> <th>(1) To (2)</th> <th>Result</th> </tr> </thead> <tbody> <tr> <td>-22°F / -30°C</td> <td>40 kΩ</td> </tr> <tr> <td>-13°F / -25°C</td> <td>30 kΩ</td> </tr> <tr> <td>-4°F / -20°C</td> <td>23 kΩ</td> </tr> <tr> <td>5°F / -15°C</td> <td>17 kΩ</td> </tr> <tr> <td>14°F / -10°C</td> <td>13 kΩ</td> </tr> <tr> <td>23°F / -5°C</td> <td>10 kΩ</td> </tr> <tr> <td>32°F / 0°C</td> <td>8 kΩ</td> </tr> </tbody> </table> <p>* The sensor is determined by the temperature. For example, 23kΩ indicates -20°C.</p>	Result		SVC Action	0Ω	Short	Change the sensor	OFF	Open	Replace the refrigerator	Other	Normal	Check the Temp and resistance (Table-1)	(1) To (2)	Result	-22°F / -30°C	40 kΩ	-13°F / -25°C	30 kΩ	-4°F / -20°C	23 kΩ	5°F / -15°C	17 kΩ	14°F / -10°C	13 kΩ	23°F / -5°C	10 kΩ	32°F / 0°C	8 kΩ
Result		SVC Action																												
0Ω	Short	Change the sensor																												
OFF	Open	Replace the refrigerator																												
Other	Normal	Check the Temp and resistance (Table-1)																												
(1) To (2)	Result																													
-22°F / -30°C	40 kΩ																													
-13°F / -25°C	30 kΩ																													
-4°F / -20°C	23 kΩ																													
5°F / -15°C	17 kΩ																													
14°F / -10°C	13 kΩ																													
23°F / -5°C	10 kΩ																													
32°F / 0°C	8 kΩ																													

# Troubleshooting With Error Display

## 2. Refrigerator Sensor Error (rS E)





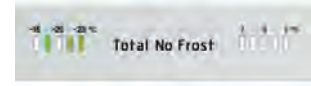

Step No	Checking flow	Result & SVC Action																								
1	Check for a loose connection.																									
2	<ul style="list-style-type: none"> <li>Linear A++, A+++ Check the <u>Pin9(1) to Pin10(2)</u> of CON6. Check the <u>Pin9(1) to Pin10(2)</u> of CON7.</li> </ul>   <ul style="list-style-type: none"> <li>A ++, A+ Check the <u>Pin3(1) to Pin4(2)</u> of CON6. Check the <u>Pin9(1) to Pin10(2)</u> of CON7.</li> </ul>  	<table border="1"> <thead> <tr> <th colspan="2">Result</th> <th>SVC Action</th> </tr> </thead> <tbody> <tr> <td>0Ω</td> <td>Short</td> <td>Change the sensor</td> </tr> <tr> <td>OFF</td> <td>Open</td> <td>Replace the refrigerator</td> </tr> <tr> <td>Other</td> <td>Normal</td> <td>Check the Temp and resistance (Table-2)</td> </tr> </tbody> </table> <p>&lt;Temperature table-2&gt;</p> <table border="1"> <thead> <tr> <th>(1) To (2)</th> <th>Result</th> </tr> </thead> <tbody> <tr> <td>23°F / -5°C</td> <td>38 kΩ</td> </tr> <tr> <td>32°F / 0°C</td> <td>30 kΩ</td> </tr> <tr> <td>41°F / 5°C</td> <td>24 kΩ</td> </tr> <tr> <td>50°F / 10°C</td> <td>19.5 kΩ</td> </tr> <tr> <td>59°F / 15°C</td> <td>16 kΩ</td> </tr> </tbody> </table> <p>* The sensor is determined by the temperature. For example, 30kΩ indicates 0°C.</p>	Result		SVC Action	0Ω	Short	Change the sensor	OFF	Open	Replace the refrigerator	Other	Normal	Check the Temp and resistance (Table-2)	(1) To (2)	Result	23°F / -5°C	38 kΩ	32°F / 0°C	30 kΩ	41°F / 5°C	24 kΩ	50°F / 10°C	19.5 kΩ	59°F / 15°C	16 kΩ
Result		SVC Action																								
0Ω	Short	Change the sensor																								
OFF	Open	Replace the refrigerator																								
Other	Normal	Check the Temp and resistance (Table-2)																								
(1) To (2)	Result																									
23°F / -5°C	38 kΩ																									
32°F / 0°C	30 kΩ																									
41°F / 5°C	24 kΩ																									
50°F / 10°C	19.5 kΩ																									
59°F / 15°C	16 kΩ																									

# Troubleshooting With Error Display

## 3. Refrigerator Sensor Error(rt E)







Step No	Checking flow	Result & SVC Action																								
1	Check for a loose connection.																									
2	<ul style="list-style-type: none"> <li>Linear A++, A+++ Check the <u>Pin13(1) to Pin14(2) of CON6.</u>  Check the <u>Pin13(1) to Pin14(2) of CON7.</u></li> </ul> <div style="display: flex; justify-content: space-around; margin-top: 10px;"> <div style="text-align: center;"> <p>CON 6</p>  </div> <div style="text-align: center;"> <p>CON 7</p>  </div> </div>  <ul style="list-style-type: none"> <li>A ++, A+ Check the <u>Pin3(1) to Pin4(2) of CON6.</u>  Check the <u>Pin13(1) to Pin14(2) of CON7.</u></li> </ul> <div style="display: flex; justify-content: space-around; margin-top: 10px;"> <div style="text-align: center;"> <p>CON 6</p>  </div> <div style="text-align: center;"> <p>CON 7</p>  </div> </div>	<table border="1" style="width: 100%; border-collapse: collapse; margin-bottom: 20px;"> <thead> <tr style="background-color: #0070C0; color: white;"> <th colspan="2">Result</th> <th>SVC Action</th> </tr> </thead> <tbody> <tr> <td style="text-align: center;">0Ω</td> <td style="text-align: center;">Short</td> <td>Change the sensor</td> </tr> <tr> <td style="text-align: center;">OFF</td> <td style="text-align: center;">Open</td> <td>Replace the refrigerator</td> </tr> <tr> <td style="text-align: center;">Other</td> <td style="text-align: center;">Normal</td> <td>Check the Temp and resistance (Table-2)</td> </tr> </tbody> </table> <p style="text-align: center; margin-bottom: 10px;">&lt;Temperature table-2&gt;</p> <table border="1" style="width: 100%; border-collapse: collapse;"> <thead> <tr style="background-color: #FFD700;"> <th>(1) To (2)</th> <th>Result</th> </tr> </thead> <tbody> <tr> <td style="text-align: center;">23°F / -5°C</td> <td style="text-align: center;">38 kΩ</td> </tr> <tr> <td style="text-align: center;">32°F / 0°C</td> <td style="text-align: center;">30 kΩ</td> </tr> <tr> <td style="text-align: center;">41°F / 5°C</td> <td style="text-align: center;">24 kΩ</td> </tr> <tr> <td style="text-align: center;">50°F / 10°C</td> <td style="text-align: center;">19.5 kΩ</td> </tr> <tr> <td style="text-align: center;">59°F / 15°C</td> <td style="text-align: center;">16 kΩ</td> </tr> </tbody> </table> <p>※ The sensor is determined by the temperature. For example, 30kΩ indicates 0°C.</p>	Result		SVC Action	0Ω	Short	Change the sensor	OFF	Open	Replace the refrigerator	Other	Normal	Check the Temp and resistance (Table-2)	(1) To (2)	Result	23°F / -5°C	38 kΩ	32°F / 0°C	30 kΩ	41°F / 5°C	24 kΩ	50°F / 10°C	19.5 kΩ	59°F / 15°C	16 kΩ
Result		SVC Action																								
0Ω	Short	Change the sensor																								
OFF	Open	Replace the refrigerator																								
Other	Normal	Check the Temp and resistance (Table-2)																								
(1) To (2)	Result																									
23°F / -5°C	38 kΩ																									
32°F / 0°C	30 kΩ																									
41°F / 5°C	24 kΩ																									
50°F / 10°C	19.5 kΩ																									
59°F / 15°C	16 kΩ																									

# Troubleshooting With Error Display

## 4. Defrost Sensor Error (dS F)







Step No	Checking flow	Result & SVC Action
1	<p data-bbox="298 463 735 491">Check for a loose connection.</p>  <ul data-bbox="269 774 548 802" style="list-style-type: none"> <li>• Linear A++, A+++</li> </ul> <div style="display: flex; justify-content: space-around;"> <div data-bbox="269 859 521 1229"> <p data-bbox="451 859 537 887">CON 6</p>  </div> <div data-bbox="581 859 833 1229"> <p data-bbox="724 859 810 887">CON 7</p>  </div> </div> <ul data-bbox="269 1385 407 1412" style="list-style-type: none"> <li>• A ++, A+</li> </ul> <div style="display: flex; justify-content: space-around;"> <div data-bbox="282 1449 553 1789"> <p data-bbox="483 1449 570 1476">CON 6</p>  </div> <div data-bbox="602 1449 849 1817"> <p data-bbox="761 1449 847 1476">CON 7</p>  </div> </div>	

# Troubleshooting With Error Display

## 4. Defrost Sensor Error (dS F)

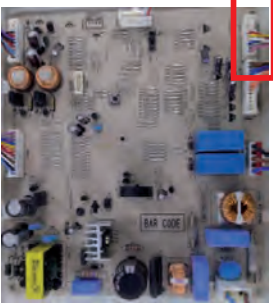



Step No	Checking flow	Result & SVC Action																												
2	<ul style="list-style-type: none"> <li>Linear A++, A+++ Check the <u>Pin 7(1) to Pin8(2) of CON6.</u>  Check the <u>Pin 7 to Pin8(2) of CON7.</u></li> </ul> <div style="display: flex; justify-content: space-around; align-items: center;"> <div style="text-align: center;"> <p>CON 6</p>  </div> <div style="text-align: center;"> <p>CON 7</p>  </div> </div> <ul style="list-style-type: none"> <li>A ++, A+ Check the <u>Pin 7 (1) to Pin 8 (2) of CON6.</u>  Check the <u>Pin7(1) to Pin8(2) of CON7.</u></li> </ul> <div style="display: flex; justify-content: space-around; align-items: center;"> <div style="text-align: center;"> <p>CON 6</p>  </div> <div style="text-align: center;"> <p>CON 7</p>  </div> </div>	<table border="1" style="width: 100%; border-collapse: collapse;"> <thead> <tr style="background-color: #0070C0; color: white;"> <th colspan="2">Result</th> <th>SVC Action</th> </tr> </thead> <tbody> <tr> <td style="text-align: center;">0Ω</td> <td style="text-align: center;">Short</td> <td style="text-align: center;">Change the sensor</td> </tr> <tr> <td style="text-align: center;">OFF</td> <td style="text-align: center;">Open</td> <td style="text-align: center;">Replace the refrigerator</td> </tr> <tr> <td style="text-align: center;">Other</td> <td style="text-align: center;">Normal</td> <td style="text-align: center;">Check the Temp and resistance (Table-3)</td> </tr> </tbody> </table> <p style="text-align: center;">&lt;Temperature table-3&gt;</p> <table border="1" style="width: 100%; border-collapse: collapse;"> <thead> <tr style="background-color: #FFD700;"> <th>(1) To (2)</th> <th>Result</th> </tr> </thead> <tbody> <tr> <td style="text-align: center;">-22°F / -30°C</td> <td style="text-align: center;">40 kΩ</td> </tr> <tr> <td style="text-align: center;">-13°F / -25°C</td> <td style="text-align: center;">30 kΩ</td> </tr> <tr> <td style="text-align: center;">-4°F / -20°C</td> <td style="text-align: center;">23 kΩ</td> </tr> <tr> <td style="text-align: center;">5°F / -15°C</td> <td style="text-align: center;">17 kΩ</td> </tr> <tr> <td style="text-align: center;">14°F / -10°C</td> <td style="text-align: center;">13 kΩ</td> </tr> <tr> <td style="text-align: center;">23°F / -5°C</td> <td style="text-align: center;">10 kΩ</td> </tr> <tr> <td style="text-align: center;">32°F / 0°C</td> <td style="text-align: center;">8 kΩ</td> </tr> </tbody> </table> <p>✳ The sensor is determined by the temperature. For example, 23kΩ indicates -20°C.</p>	Result		SVC Action	0Ω	Short	Change the sensor	OFF	Open	Replace the refrigerator	Other	Normal	Check the Temp and resistance (Table-3)	(1) To (2)	Result	-22°F / -30°C	40 kΩ	-13°F / -25°C	30 kΩ	-4°F / -20°C	23 kΩ	5°F / -15°C	17 kΩ	14°F / -10°C	13 kΩ	23°F / -5°C	10 kΩ	32°F / 0°C	8 kΩ
Result		SVC Action																												
0Ω	Short	Change the sensor																												
OFF	Open	Replace the refrigerator																												
Other	Normal	Check the Temp and resistance (Table-3)																												
(1) To (2)	Result																													
-22°F / -30°C	40 kΩ																													
-13°F / -25°C	30 kΩ																													
-4°F / -20°C	23 kΩ																													
5°F / -15°C	17 kΩ																													
14°F / -10°C	13 kΩ																													
23°F / -5°C	10 kΩ																													
32°F / 0°C	8 kΩ																													

# Troubleshooting With Error Display

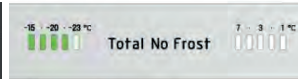
## 5. Defrost Heater Error (dH F)





No	Checking flow	Result & SVC Action														
1	Check the <u>Door gasket.</u>	<table border="1"> <thead> <tr> <th>Part</th> <th>Result</th> <th>SVC Action</th> </tr> </thead> <tbody> <tr> <td rowspan="3">Def' Heater &amp; Fuse-M</td> <td>220V : 167~205 Ω</td> <td rowspan="2">Go to the 3</td> </tr> <tr> <td>240V : 199~244 Ω</td> </tr> <tr> <td>Other</td> <td>Change Fuse-M</td> </tr> <tr> <td rowspan="2">Def' sensor</td> <td>Normal (Check the Temp and resistance)</td> <td>Go to the 3</td> </tr> <tr> <td>Other</td> <td>Change the sensor</td> </tr> </tbody> </table>	Part	Result	SVC Action	Def' Heater & Fuse-M	220V : 167~205 Ω	Go to the 3	240V : 199~244 Ω	Other	Change Fuse-M	Def' sensor	Normal (Check the Temp and resistance)	Go to the 3	Other	Change the sensor
Part	Result		SVC Action													
Def' Heater & Fuse-M	220V : 167~205 Ω	Go to the 3														
	240V : 199~244 Ω															
	Other	Change Fuse-M														
Def' sensor	Normal (Check the Temp and resistance)	Go to the 3														
	Other	Change the sensor														
2	Check the <u>Defrost control part.</u>															
3	Input Test 2 Mode. (Push the button 2 times)															
4	<p>Check the <u>Brown to Blue.</u></p> <p>Linear A++, A+++                      A++, A+</p> <p>CON3</p>  <p>FMA and BMG</p> <p>CON2</p> 	<table border="1"> <thead> <tr> <th>Result</th> <th>SVC Action</th> </tr> </thead> <tbody> <tr> <td>220 ~ 240 V</td> <td>Go to the 5</td> </tr> <tr> <td>0 V</td> <td>Replace Main PCB</td> </tr> </tbody> </table>	Result	SVC Action	220 ~ 240 V	Go to the 5	0 V	Replace Main PCB								
Result	SVC Action															
220 ~ 240 V	Go to the 5															
0 V	Replace Main PCB															

# Troubleshooting With Error Display

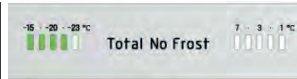
## 5. Defrost Heater Error (dH F)





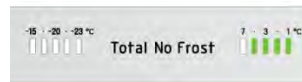

No	Checking flow	Result & SVC Action						
5	Release the test mode. Push the button 1 times. (Normal)							
6	<p>Check the <u>Brown to Blue.</u></p> <p>Linear A++, A+++      A++, A+</p> <p>CON3</p>  <p>FMA and BMG CON2</p> 	<table border="1" data-bbox="927 789 1408 938"> <thead> <tr> <th>Result</th> <th>SVC Action</th> </tr> </thead> <tbody> <tr> <td>0 V</td> <td>Explain to customer</td> </tr> <tr> <td>220 ~ 240 V</td> <td>Replace Main PCB</td> </tr> </tbody> </table>	Result	SVC Action	0 V	Explain to customer	220 ~ 240 V	Replace Main PCB
Result	SVC Action							
0 V	Explain to customer							
220 ~ 240 V	Replace Main PCB							

# Troubleshooting With Error Display

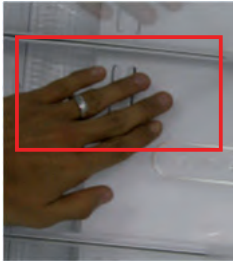
## 6. Freezer Fan Error (FF E)







No	Checking flow	Result & SVC Action						
1	Reset the unit and Input Test 1 Mode. (Push the button 1 time)							
2	Open the freezer door and Check the air flow. <ul style="list-style-type: none"> <li>• While an error code is displayed, the fan is not working.</li> </ul>	 <table border="1" data-bbox="982 1081 1305 1225"> <thead> <tr> <th>Status</th> <th>SVC Action</th> </tr> </thead> <tbody> <tr> <td>No windy</td> <td>Go to 3&amp;4</td> </tr> <tr> <td>Windy</td> <td>Go to 3&amp;4</td> </tr> </tbody> </table>	Status	SVC Action	No windy	Go to 3&4	Windy	Go to 3&4
Status	SVC Action							
No windy	Go to 3&4							
Windy	Go to 3&4							
3	Check the <u>Fan motor</u> . <div style="display: flex; justify-content: space-around; margin-top: 10px;">    </div>	Rotate fan using your hand. It feel sticky, change the motor. (Cause of ice or rust inside of motor)						

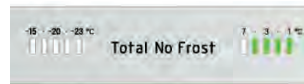

# Troubleshooting With Error Display

## 6. Freezer Fan Error (FF E)

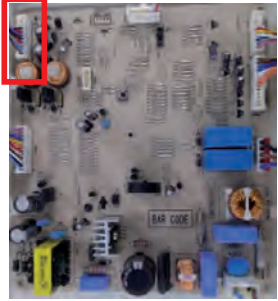



No	Checking flow	Result & SVC Action																					
4	<ul style="list-style-type: none"> <li>Linear A++, A+++</li> </ul> <p>Check the Fan motor voltage. <u>Pin9(1), Pin10(2), Pin11(3)</u> <u>of CON14.</u></p> <p>Check the <u>Pin7(2) to Pin8(3)</u> <u>of CON13.</u></p> <div style="display: flex; justify-content: space-around;"> <div style="text-align: center;"> <p>CON 14</p>  </div> <div style="text-align: center;"> <p>CON 13</p>  </div> </div> <ul style="list-style-type: none"> <li>A++, A+</li> </ul> <p>Check the Fan motor voltage. <u>Pin4(1), Pin5(2), Pin6(3)</u> <u>of CON4.</u></p> <p>Check the <u>Pin6(2) to Pin7(3)</u> of CON13 Check the <u>Pin6(2) to Pin8(4)</u> of CON13</p> <div style="display: flex; justify-content: space-around;"> <div style="text-align: center;"> <p>CON4</p>  </div> <div style="text-align: center;"> <p>CON 13</p>  </div> </div>	<table border="1" style="width: 100%; border-collapse: collapse;"> <thead> <tr style="background-color: #FFD700;"> <th>Point</th> <th>Result</th> <th>SVC Action</th> </tr> </thead> <tbody> <tr> <td>(1) ~ (2)</td> <td>Below 12 V</td> <td>Change the PCB</td> </tr> <tr> <td>(2) ~ (3)</td> <td>0 or 5 V</td> <td>Change the motor</td> </tr> </tbody> </table> <p>FMA and BMG</p> <table border="1" style="width: 100%; border-collapse: collapse;"> <thead> <tr style="background-color: #FFD700;"> <th>Point</th> <th>Result</th> <th>SVC Action</th> </tr> </thead> <tbody> <tr> <td>(1) ~ (2)</td> <td>Below 11.4 V</td> <td>Change the PCB</td> </tr> <tr> <td>(2) ~ (3)</td> <td>0 or 5 V</td> <td>Change the motor</td> </tr> <tr> <td>(2) ~ (4)</td> <td>0 or 5 V</td> <td>Change the motor</td> </tr> </tbody> </table>	Point	Result	SVC Action	(1) ~ (2)	Below 12 V	Change the PCB	(2) ~ (3)	0 or 5 V	Change the motor	Point	Result	SVC Action	(1) ~ (2)	Below 11.4 V	Change the PCB	(2) ~ (3)	0 or 5 V	Change the motor	(2) ~ (4)	0 or 5 V	Change the motor
Point	Result	SVC Action																					
(1) ~ (2)	Below 12 V	Change the PCB																					
(2) ~ (3)	0 or 5 V	Change the motor																					
Point	Result	SVC Action																					
(1) ~ (2)	Below 11.4 V	Change the PCB																					
(2) ~ (3)	0 or 5 V	Change the motor																					
(2) ~ (4)	0 or 5 V	Change the motor																					

# Troubleshooting With Error Display

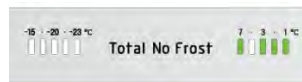
## 7. Condenser Fan Error (CF E)

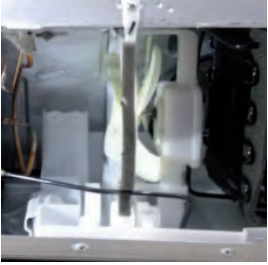

No	Checking flow	Result & SVC Action						
1	Reset the unit and Input Test 1 Mode. (Push the button 1 time)							
2	Check the fan rotating. <ul style="list-style-type: none"> <li>While an error code is displayed, the fan is not working.</li> </ul>	 <table border="1" data-bbox="976 1102 1300 1293"> <thead> <tr> <th>Status</th> <th>SVC Action</th> </tr> </thead> <tbody> <tr> <td>No windy</td> <td>Check PCB &amp; motor</td> </tr> <tr> <td>Windy</td> <td>Go to the 5</td> </tr> </tbody> </table>	Status	SVC Action	No windy	Check PCB & motor	Windy	Go to the 5
Status	SVC Action							
No windy	Check PCB & motor							
Windy	Go to the 5							
3	Check the <u>Fan motor</u> and <u>surrounding</u> .  	Rotate fan using your hand. It feel sticky, change the motor.						

# Troubleshooting With Error Display

## 7. Condenser Fan Error (CF E)

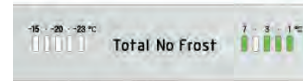











No	Checking flow	Result & SVC Action																					
4	<ul style="list-style-type: none"> <li>Linear A++, A+++ Check the Fan motor voltage. <u>Pin6(1), Pin7(2), Pin8(3)</u> <u>of CON14.</u></li> <li>Check the <u>Pin3(2) to Pin4(3)</u> <u>of CON13.</u></li> </ul> <div style="display: flex; justify-content: space-around;"> <div data-bbox="269 804 516 1174"> <p>CON 14</p> </div> <div data-bbox="561 804 789 1174"> <p>CON 13</p> </div> </div> <ul style="list-style-type: none"> <li>A++, A+ Check the Fan motor voltage. <u>Pin1(1), Pin2(2), Pin3(3)</u> <u>of CON4.</u></li> <li>Check the <u>Pin2(2) to Pin3(3) of CON13</u> Check the <u>Pin2(2) to Pin4(4) of CON13</u></li> </ul> <div style="display: flex; justify-content: space-around;"> <div data-bbox="269 1613 548 1974"> <p>CON4</p> </div> <div data-bbox="561 1613 828 1996"> <p>CON 13</p> </div> </div>	<table border="1" style="width: 100%; border-collapse: collapse;"> <thead> <tr style="background-color: #FFD700;"> <th></th> <th>Result</th> <th>SVC Action</th> </tr> </thead> <tbody> <tr> <td>(1) ~ (2)</td> <td>Below 12 V</td> <td>Change the PCB</td> </tr> <tr> <td>(2) ~ (3)</td> <td>0 or 5 V</td> <td>Change the motor</td> </tr> </tbody> </table> <p>FMA and BMG</p> <table border="1" style="width: 100%; border-collapse: collapse;"> <thead> <tr style="background-color: #FFD700;"> <th>Point</th> <th>Result</th> <th>SVC Action</th> </tr> </thead> <tbody> <tr> <td>(1) ~ (2)</td> <td>Below 11.4 V</td> <td>Change the PCB</td> </tr> <tr> <td>(2) ~ (3)</td> <td>0 or 5 V</td> <td>Change the motor</td> </tr> <tr> <td>(2) ~ (4)</td> <td>0 or 5 V</td> <td>Change the motor</td> </tr> </tbody> </table>		Result	SVC Action	(1) ~ (2)	Below 12 V	Change the PCB	(2) ~ (3)	0 or 5 V	Change the motor	Point	Result	SVC Action	(1) ~ (2)	Below 11.4 V	Change the PCB	(2) ~ (3)	0 or 5 V	Change the motor	(2) ~ (4)	0 or 5 V	Change the motor
	Result	SVC Action																					
(1) ~ (2)	Below 12 V	Change the PCB																					
(2) ~ (3)	0 or 5 V	Change the motor																					
Point	Result	SVC Action																					
(1) ~ (2)	Below 11.4 V	Change the PCB																					
(2) ~ (3)	0 or 5 V	Change the motor																					
(2) ~ (4)	0 or 5 V	Change the motor																					

# Troubleshooting With Error Display



## 8. Communication Error (Er CO)



No	Checking flow	Result & SVC Action						
1	Check the loose connection.							
2	Check the Orange to Black.   <CON101_display>	<table border="1"> <thead> <tr> <th>Result</th> <th>SVC Action</th> </tr> </thead> <tbody> <tr> <td>12 V</td> <td>Go to the 3</td> </tr> <tr> <td>Other</td> <td>Check the Hinge (Loose connection) Change the Main PCB</td> </tr> </tbody> </table>	Result	SVC Action	12 V	Go to the 3	Other	Check the Hinge (Loose connection) Change the Main PCB
Result	SVC Action							
12 V	Go to the 3							
Other	Check the Hinge (Loose connection) Change the Main PCB							
3	Check the Brown to Black.   <CON101_display>	<table border="1"> <thead> <tr> <th>Result</th> <th>SVC Action</th> </tr> </thead> <tbody> <tr> <td>0 V or 5 V</td> <td>Change the Display PCB</td> </tr> <tr> <td>Other</td> <td>Go to the 4</td> </tr> </tbody> </table>	Result	SVC Action	0 V or 5 V	Change the Display PCB	Other	Go to the 4
Result	SVC Action							
0 V or 5 V	Change the Display PCB							
Other	Go to the 4							
4	Check the Red to Black.   <CON101_display>	<table border="1"> <thead> <tr> <th>Result</th> <th>SVC Action</th> </tr> </thead> <tbody> <tr> <td>0 V or 5 V</td> <td>Change the Display PCB</td> </tr> <tr> <td>Other</td> <td>Go to the 5</td> </tr> </tbody> </table>	Result	SVC Action	0 V or 5 V	Change the Display PCB	Other	Go to the 5
Result	SVC Action							
0 V or 5 V	Change the Display PCB							
Other	Go to the 5							
5	Check the Brown to Black.  <CON10_Main>   <CON9_Main>	<table border="1"> <thead> <tr> <th>Result</th> <th>SVC Action</th> </tr> </thead> <tbody> <tr> <td>0 V or 5 V</td> <td>Change the Display PCB</td> </tr> <tr> <td>Other</td> <td>Go to the 6</td> </tr> </tbody> </table>	Result	SVC Action	0 V or 5 V	Change the Display PCB	Other	Go to the 6
Result	SVC Action							
0 V or 5 V	Change the Display PCB							
Other	Go to the 6							
6	Check the Red to Black.  <CON10_Main>   <CON9_Main>	<table border="1"> <thead> <tr> <th>Result</th> <th>SVC Action</th> </tr> </thead> <tbody> <tr> <td>0 V or 5 V</td> <td>Change the Display PCB</td> </tr> <tr> <td>Other</td> <td>Explain to customer</td> </tr> </tbody> </table>	Result	SVC Action	0 V or 5 V	Change the Display PCB	Other	Explain to customer
Result	SVC Action							
0 V or 5 V	Change the Display PCB							
Other	Explain to customer							

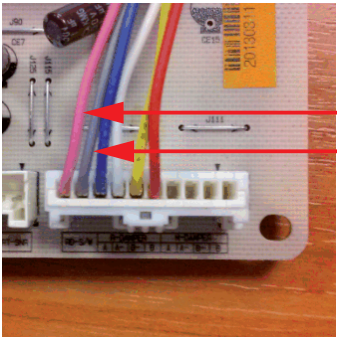

# Troubleshooting Without Error Display

## 1. Refrigerator room lamp doesn't work

No	Checking flow	Result & SVC Action													
1	Check the loose connection.														
2	Check the Refrigerator door switch.	If feel sticky, Change the door s/w.													
3	<p>Check the <u>door S/W</u> resistance.</p> 	<table border="1"> <thead> <tr> <th>Status</th> <th>Result</th> <th>SVC Action</th> </tr> </thead> <tbody> <tr> <td rowspan="2">Normal</td> <td>0Ω</td> <td>Go to the 3</td> </tr> <tr> <td>not</td> <td>Change door S/W</td> </tr> <tr> <td rowspan="2">Push S/W</td> <td>Infinity</td> <td>Go to the 3</td> </tr> <tr> <td></td> <td>Change door S/W</td> </tr> </tbody> </table>	Status	Result	SVC Action	Normal	0Ω	Go to the 3	not	Change door S/W	Push S/W	Infinity	Go to the 3		Change door S/W
Status	Result	SVC Action													
Normal	0Ω	Go to the 3													
	not	Change door S/W													
Push S/W	Infinity	Go to the 3													
		Change door S/W													
4	<p>Linear A++, A+++            Check CON6, <u>Pin 1 &amp; 2</u>            Check CON7, <u>Pin 1 &amp; 2</u></p>  <p>FMA and BGM            Check CON7, <u>Pin 3 &amp; 4</u></p>  <p>A++, A+            Check CON7, <u>Pin 1 &amp; 2</u></p> 	<table border="1"> <thead> <tr> <th>Status</th> <th>Result</th> <th>SVC Action</th> </tr> </thead> <tbody> <tr> <td rowspan="2">Closed</td> <td>12 V</td> <td>Go to the 4</td> </tr> <tr> <td>Other</td> <td>Change the PCB</td> </tr> <tr> <td rowspan="2">Open</td> <td>0 V</td> <td>Go to the 4</td> </tr> <tr> <td>Other</td> <td>Change the PCB</td> </tr> </tbody> </table>	Status	Result	SVC Action	Closed	12 V	Go to the 4	Other	Change the PCB	Open	0 V	Go to the 4	Other	Change the PCB
Status	Result	SVC Action													
Closed	12 V	Go to the 4													
	Other	Change the PCB													
Open	0 V	Go to the 4													
	Other	Change the PCB													

# Troubleshooting Without Error Display

## 2. Poor cooling in Freezer compartment

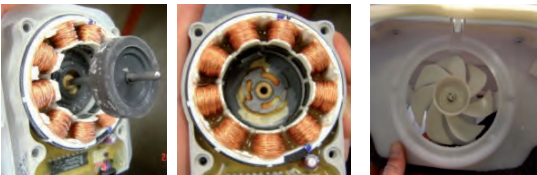
Step No	Check Item	Result & SVC Action																
1	<p>Check the sensor resistance.</p> <ul style="list-style-type: none"> <li>The sensor is determined by the temperature. For example, 23KΩ indicates -20°C</li> </ul>	<table border="1"> <thead> <tr> <th>(1) To (2)</th> <th>Result</th> </tr> </thead> <tbody> <tr> <td>-22°F / -30°C</td> <td>40 kΩ</td> </tr> <tr> <td>-13°F / -25°C</td> <td>30 kΩ</td> </tr> <tr> <td>-4°F / -20°C</td> <td>23 kΩ</td> </tr> <tr> <td>5°F / -15°C</td> <td>17 kΩ</td> </tr> <tr> <td>14°F / -10°C</td> <td>13 kΩ</td> </tr> <tr> <td>23°F / -5°C</td> <td>10 kΩ</td> </tr> <tr> <td>32°F / 0°C</td> <td>8 kΩ</td> </tr> </tbody> </table>	(1) To (2)	Result	-22°F / -30°C	40 kΩ	-13°F / -25°C	30 kΩ	-4°F / -20°C	23 kΩ	5°F / -15°C	17 kΩ	14°F / -10°C	13 kΩ	23°F / -5°C	10 kΩ	32°F / 0°C	8 kΩ
(1) To (2)	Result																	
-22°F / -30°C	40 kΩ																	
-13°F / -25°C	30 kΩ																	
-4°F / -20°C	23 kΩ																	
5°F / -15°C	17 kΩ																	
14°F / -10°C	13 kΩ																	
23°F / -5°C	10 kΩ																	
32°F / 0°C	8 kΩ																	
2	<p>Reset the unit and Input Test 1 Mode. (push the button 1 time)</p>																	
3	<p>Open the freezer door and Check the air flow.</p> 	<table border="1"> <thead> <tr> <th>Status</th> <th>SVC Action</th> </tr> </thead> <tbody> <tr> <td>Windy</td> <td>Go to the 4</td> </tr> <tr> <td>No windy</td> <td>Check the Fan motor (Next page) &amp; PCB</td> </tr> </tbody> </table>	Status	SVC Action	Windy	Go to the 4	No windy	Check the Fan motor (Next page) & PCB										
Status	SVC Action																	
Windy	Go to the 4																	
No windy	Check the Fan motor (Next page) & PCB																	
4	<p>Check the air temperature. Cold or not ?</p>	<table border="1"> <thead> <tr> <th>Status</th> <th>SVC Action</th> </tr> </thead> <tbody> <tr> <td>Cold</td> <td>Explain to customer</td> </tr> <tr> <td>Not cold</td> <td>Check the Compressor And sealed system</td> </tr> </tbody> </table>	Status	SVC Action	Cold	Explain to customer	Not cold	Check the Compressor And sealed system										
Status	SVC Action																	
Cold	Explain to customer																	
Not cold	Check the Compressor And sealed system																	
5	<p>Check the <u>Fan motor</u>. Rotate fan using your hand. It feel sticky, change the motor. (cause of ice or rust inside of motor)</p> 	<table border="1"> <thead> <tr> <th>Point</th> <th>Result</th> <th>SVC Action</th> </tr> </thead> <tbody> <tr> <td>Motor</td> <td>Sticky</td> <td>Change the motor</td> </tr> </tbody> </table>	Point	Result	SVC Action	Motor	Sticky	Change the motor										
Point	Result	SVC Action																
Motor	Sticky	Change the motor																

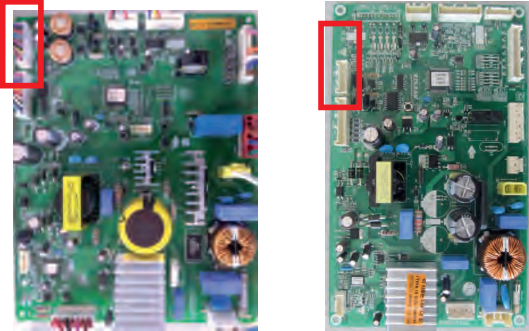
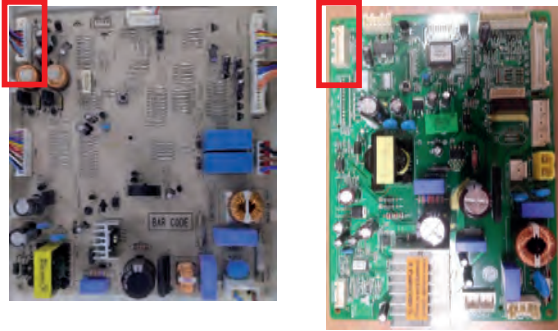

# Troubleshooting Without Error Display

## 2. Poor cooling in Freezer compartment

Step No	Check Item	Result & SVC Action																					
6	<p>• Linear A++, A+++  <u>Check the Fan motor voltage. Pin9(1), Pin10(2), Pin11(3) of CON14.</u>  <u>Check the Pin7(2) to Pin8(3) of CON13.</u></p> <p>CON 14                      CON 13</p>  <p>• A++, A+  <u>Check the Fan motor voltage. Pin4(1), Pin5(2), Pin6(3) of CON4.</u>  <u>Check the Pin6(2) to Pin7(3) of CON13</u>  <u>Check the Pin6(2) to Pin8(4) of CON13</u></p> <p>CON4                              CON 13</p> 	<table border="1" data-bbox="894 519 1451 689"> <thead> <tr> <th>Point</th> <th>Result</th> <th>SVC Action</th> </tr> </thead> <tbody> <tr> <td>(1)~(2)</td> <td>Below 12V</td> <td>Change the PCB</td> </tr> <tr> <td>(2)~(3)</td> <td>0 or 5 V</td> <td>Change the motor</td> </tr> </tbody> </table> <p>FMA and BMG</p> <table border="1" data-bbox="894 802 1456 1000"> <thead> <tr> <th>Point</th> <th>Result</th> <th>SVC Action</th> </tr> </thead> <tbody> <tr> <td>(1) ~ (2)</td> <td>Below 11.4 V</td> <td>Change the PCB</td> </tr> <tr> <td>(2) ~ (3)</td> <td>0 or 5 V</td> <td>Change the motor</td> </tr> <tr> <td>(2) ~ (4)</td> <td>0 or 5 V</td> <td>Change the motor</td> </tr> </tbody> </table>	Point	Result	SVC Action	(1)~(2)	Below 12V	Change the PCB	(2)~(3)	0 or 5 V	Change the motor	Point	Result	SVC Action	(1) ~ (2)	Below 11.4 V	Change the PCB	(2) ~ (3)	0 or 5 V	Change the motor	(2) ~ (4)	0 or 5 V	Change the motor
Point	Result	SVC Action																					
(1)~(2)	Below 12V	Change the PCB																					
(2)~(3)	0 or 5 V	Change the motor																					
Point	Result	SVC Action																					
(1) ~ (2)	Below 11.4 V	Change the PCB																					
(2) ~ (3)	0 or 5 V	Change the motor																					
(2) ~ (4)	0 or 5 V	Change the motor																					

# Troubleshooting Without Error Display

## 3. Poor cooling in Refrigerator compartment

Step No	Check Item	Result & SVC Action												
1	<p>Check the sensor resistance.</p> <ul style="list-style-type: none"> <li>The sensor is determined by the temperature. For example, 30KΩ indicates 0°C.</li> </ul>	<table border="1"> <thead> <tr> <th>(1) To (2)</th> <th>Result</th> </tr> </thead> <tbody> <tr> <td>23°F / -5°C</td> <td>38 kΩ</td> </tr> <tr> <td>32°F / 0°C</td> <td>30 kΩ</td> </tr> <tr> <td>41°F / 5°C</td> <td>24 kΩ</td> </tr> <tr> <td>50°F / 10°C</td> <td>19,5 kΩ</td> </tr> <tr> <td>59°F / 15°C</td> <td>16 kΩ</td> </tr> </tbody> </table>	(1) To (2)	Result	23°F / -5°C	38 kΩ	32°F / 0°C	30 kΩ	41°F / 5°C	24 kΩ	50°F / 10°C	19,5 kΩ	59°F / 15°C	16 kΩ
(1) To (2)	Result													
23°F / -5°C	38 kΩ													
32°F / 0°C	30 kΩ													
41°F / 5°C	24 kΩ													
50°F / 10°C	19,5 kΩ													
59°F / 15°C	16 kΩ													
2	<p>Reset the unit and Input Test 1 Mode. (push the button 1 time)</p>													
3	<p>Check Voltage DEF Heater</p> 	<table border="1"> <thead> <tr> <th>Status</th> <th>SVC Action</th> </tr> </thead> <tbody> <tr> <td>Windy</td> <td>Go to the 4</td> </tr> <tr> <td>No windy</td> <td>Check the Fan motor (Next page) &amp; PCB</td> </tr> </tbody> </table>	Status	SVC Action	Windy	Go to the 4	No windy	Check the Fan motor (Next page) & PCB						
Status	SVC Action													
Windy	Go to the 4													
No windy	Check the Fan motor (Next page) & PCB													
4	<p>Open the opti-zone door and Check the air flow.</p>	<table border="1"> <thead> <tr> <th>Status</th> <th>SVC Action</th> </tr> </thead> <tbody> <tr> <td>Windy</td> <td>Go to the 5</td> </tr> <tr> <td>No windy</td> <td>Check the damper (Go to the 6)</td> </tr> </tbody> </table>	Status	SVC Action	Windy	Go to the 5	No windy	Check the damper (Go to the 6)						
Status	SVC Action													
Windy	Go to the 5													
No windy	Check the damper (Go to the 6)													
5	<p>Check the air temperature. Cold or not ?</p>	<table border="1"> <thead> <tr> <th>Status</th> <th>SVC Action</th> </tr> </thead> <tbody> <tr> <td>Cold</td> <td>Explain to customer</td> </tr> <tr> <td>Not cold</td> <td>Check the Compressor And sealed system</td> </tr> </tbody> </table>	Status	SVC Action	Cold	Explain to customer	Not cold	Check the Compressor And sealed system						
Status	SVC Action													
Cold	Explain to customer													
Not cold	Check the Compressor And sealed system													



# Troubleshooting Without Error Display

## 3. Poor cooling in Refrigerator compartment

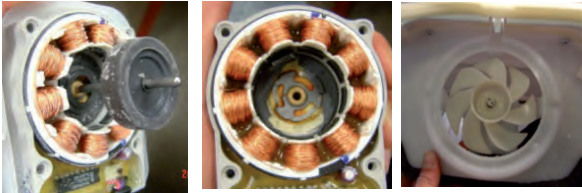
Step No	Check Item	Result & SVC Action											
6	<p>Damper checking method. Inputting TEST Mode, Check the damper and PCB</p> 	<table border="1"> <thead> <tr> <th>Point</th> <th>Result</th> <th>SVC Action</th> </tr> </thead> <tbody> <tr> <td>1Mode</td> <td>Open</td> <td rowspan="2">Damper is normal. (Go to the 7)</td> </tr> <tr> <td>2Mode</td> <td>Closed</td> </tr> <tr> <td>1,2 mode</td> <td>Not working</td> <td>Change the damper</td> </tr> </tbody> </table>	Point	Result	SVC Action	1Mode	Open	Damper is normal. (Go to the 7)	2Mode	Closed	1,2 mode	Not working	Change the damper
Point	Result	SVC Action											
1Mode	Open	Damper is normal. (Go to the 7)											
2Mode	Closed												
1,2 mode	Not working	Change the damper											
7	<p>Check the Fan motor. Rotate fan using your hand. It feel sticky, change the motor. (cause of ice or rust inside of motor)</p> 	<table border="1"> <thead> <tr> <th>Point</th> <th>Result</th> <th>SVC Action</th> </tr> </thead> <tbody> <tr> <td>Motor</td> <td>Sticky</td> <td>Change the motor</td> </tr> </tbody> </table>	Point	Result	SVC Action	Motor	Sticky	Change the motor					
Point	Result	SVC Action											
Motor	Sticky	Change the motor											



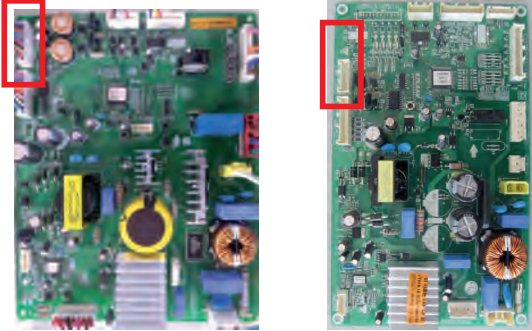
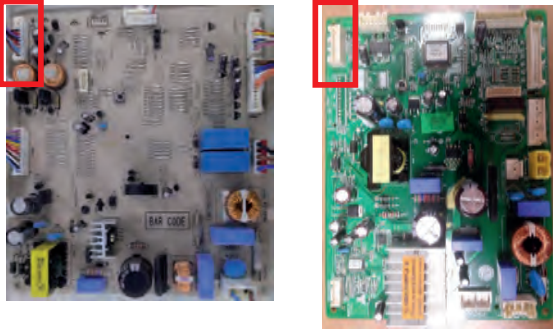

# Troubleshooting Without Error Display

## 3. Poor cooling in Refrigerator compartment

Step No	Check Item	Result & SVC Action																					
8	<p>• Linear A++, A+++ Check the Fan motor voltage. <u>Pin9(1), Pin10(2), Pin11(3)</u> of CON14.</p> <p>Check the <u>Pin7(2) to Pin8(3)</u> of CON13.</p> <p>CON 14                      CON 13</p>  <p>• A++, A+ Check the Fan motor voltage. <u>Pin9(1), Pin10(2), Pin11(3)</u> of CON14.</p> <p>Check the <u>Pin6(2) to Pin7(3)</u> of CON13 Check the <u>Pin6(2) to Pin8(4)</u> of CON13</p> <p>CON4                              CON 13</p> 	<table border="1" data-bbox="881 583 1438 770"> <thead> <tr> <th>Point</th> <th>Result</th> <th>SVC Action</th> </tr> </thead> <tbody> <tr> <td>(1)~(2)</td> <td>Below 12V</td> <td>Change the PCB</td> </tr> <tr> <td>(2)~(3)</td> <td>0 or 5 V</td> <td>Change the motor</td> </tr> </tbody> </table> <p>FMA and BMG</p> <table border="1" data-bbox="878 895 1438 1091"> <thead> <tr> <th>Point</th> <th>Result</th> <th>SVC Action</th> </tr> </thead> <tbody> <tr> <td>(1) ~ (2)</td> <td>Below 11.4 V</td> <td>Change the PCB</td> </tr> <tr> <td>(2) ~ (3)</td> <td>0 or 5 V</td> <td>Change the motor</td> </tr> <tr> <td>(2) ~ (4)</td> <td>0 or 5 V</td> <td>Change the motor</td> </tr> </tbody> </table>	Point	Result	SVC Action	(1)~(2)	Below 12V	Change the PCB	(2)~(3)	0 or 5 V	Change the motor	Point	Result	SVC Action	(1) ~ (2)	Below 11.4 V	Change the PCB	(2) ~ (3)	0 or 5 V	Change the motor	(2) ~ (4)	0 or 5 V	Change the motor
Point	Result	SVC Action																					
(1)~(2)	Below 12V	Change the PCB																					
(2)~(3)	0 or 5 V	Change the motor																					
Point	Result	SVC Action																					
(1) ~ (2)	Below 11.4 V	Change the PCB																					
(2) ~ (3)	0 or 5 V	Change the motor																					
(2) ~ (4)	0 or 5 V	Change the motor																					

# Troubleshooting Without Error Display

## 4. Over cooling in Refrigerator compartment

No	Checking flow	Result & SVC Action												
1	<p>Check the sensor resistance.</p> <ul style="list-style-type: none"> <li>The sensor is determined by the temperature. For example, 30KΩ indicates 32°F.</li> </ul>	<table border="1"> <thead> <tr> <th>Temperature</th> <th>Result</th> </tr> </thead> <tbody> <tr> <td>23°F / -5°C</td> <td>38 kΩ</td> </tr> <tr> <td>32°F / 0°C</td> <td>30 kΩ</td> </tr> <tr> <td>41°F / 5°C</td> <td>24 kΩ</td> </tr> <tr> <td>50°F / 10°C</td> <td>19,5 kΩ</td> </tr> <tr> <td>59°F / 15°C</td> <td>16 kΩ</td> </tr> </tbody> </table>	Temperature	Result	23°F / -5°C	38 kΩ	32°F / 0°C	30 kΩ	41°F / 5°C	24 kΩ	50°F / 10°C	19,5 kΩ	59°F / 15°C	16 kΩ
Temperature	Result													
23°F / -5°C	38 kΩ													
32°F / 0°C	30 kΩ													
41°F / 5°C	24 kΩ													
50°F / 10°C	19,5 kΩ													
59°F / 15°C	16 kΩ													
2	<p>Reset the unit and Input Test 1 Mode. (push the button 1 time)</p>													
3	<p>Open the refrigerator door and Check the air flow.</p> 	<table border="1"> <thead> <tr> <th>Status</th> <th>SVC Action</th> </tr> </thead> <tbody> <tr> <td>Windy</td> <td>Go to the 4</td> </tr> <tr> <td>No windy</td> <td>Check the damper (Go to the 5)</td> </tr> </tbody> </table>	Status	SVC Action	Windy	Go to the 4	No windy	Check the damper (Go to the 5)						
Status	SVC Action													
Windy	Go to the 4													
No windy	Check the damper (Go to the 5)													
4	<p>Input Test 2 Mode and Check the air flow. (Push the button 1 time)</p> 	<table border="1"> <thead> <tr> <th>Status</th> <th>SVC Action</th> </tr> </thead> <tbody> <tr> <td>Windy</td> <td>Go to the 5</td> </tr> <tr> <td>No windy</td> <td>It's normal</td> </tr> </tbody> </table>	Status	SVC Action	Windy	Go to the 5	No windy	It's normal						
Status	SVC Action													
Windy	Go to the 5													
No windy	It's normal													
5	<p>Input Test 2 Mode and Check the air flow. (Push the button 1 time)</p> 	<table border="1"> <thead> <tr> <th>Test Mode</th> <th>Damper state</th> <th>SVC Action</th> </tr> </thead> <tbody> <tr> <td>1 Mode</td> <td>Open</td> <td rowspan="2">Damper is normal.</td> </tr> <tr> <td>2 Mode</td> <td>Closed</td> </tr> <tr> <td>1,2 mode</td> <td>Not working</td> <td>Change the damper</td> </tr> </tbody> </table>	Test Mode	Damper state	SVC Action	1 Mode	Open	Damper is normal.	2 Mode	Closed	1,2 mode	Not working	Change the damper	
Test Mode	Damper state	SVC Action												
1 Mode	Open	Damper is normal.												
2 Mode	Closed													
1,2 mode	Not working	Change the damper												

# Reference

## 1. TEST MODE and Removing TPA

### 1. How to make TEST MODE

If you push the test button on the Main PCB, the refrigerator will be enter the TEST MODE.

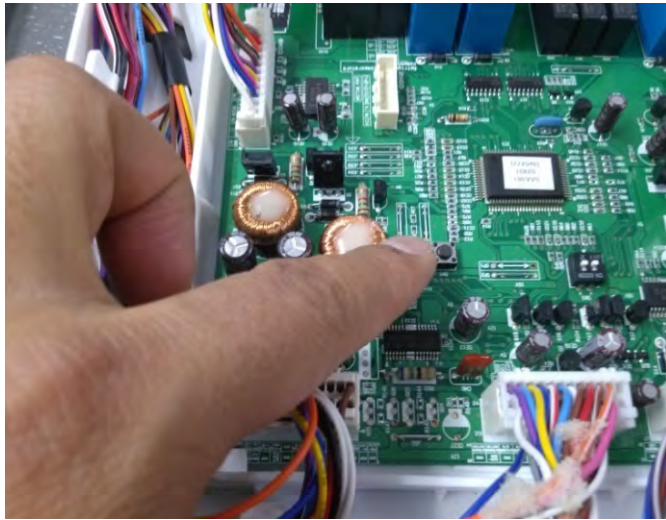

\* 1 time : Comp / Damper / All FAN on  
(All things displayed)

\* 2 times : Forced defrost mode  
(22 22 displayed)

Main PWB

### 2. How to remove Terminal Position Assurance (TPA)

<AC TPA>



<DC TPA>

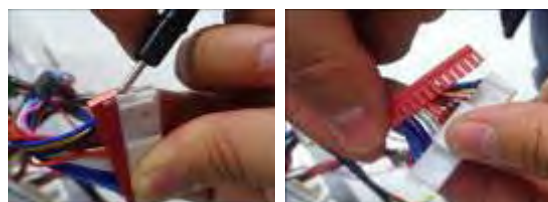

\*After measure the values, you should put in the TPA again.

# Reference

---

## 2. TEMPERATURE CHART - FRZ AND ICING SENSOR

TEMP	RESISTANCE	VOLTAGE
-39°F (-40°C)	73.29 kΩ	4.09 V
-30°F (-35°C)	53.63 kΩ	3.84 V
-21°F (-30°C)	39.66 kΩ	3.55 V
-13°F (-25°C)	29.62 kΩ	3.23 V
-4°F (-20°C)	22.33 kΩ	2.89 V
5°F (-15°C)	16.99 kΩ	2.56 V
14°F (-10°C)	13.05 kΩ	2.23 V
23°F (-5°C)	10.10 kΩ	1.92 V
32°F (0°C)	7.88 kΩ	1.63 V
41°F (5°C)	6.19 kΩ	1.38 V
50°F (10°C)	4.91 kΩ	1.16 V
59°F (15°C)	3.91 kΩ	0.97 V
68°F (20°C)	3.14 kΩ	0.81 V
77°F (25°C)	2.54 kΩ	0.67 V
86°F (30°C)	2.07 kΩ	0.56 V
95°F (35°C)	1.69 kΩ	0.47 V
104°F (40°C)	1.39 kΩ	0.39 V

# Reference

---

## 3. TEMPERATURE CHART - REF AND DEF SENSOR

TEMP	RESISTANCE	VOLTAGE
-39°F (-40°C)	225.1 kΩ	4.48 V
-30°F (-35°C)	169.8 kΩ	4.33 V
-21°F (-30°C)	129.3 kΩ	4.16 V
-13°F (-25°C)	99.30 kΩ	3.95 V
-4°F (-20°C)	76.96 kΩ	3.734 V
5°F (-15°C)	60.13 kΩ	3.487 V
14°F (-10°C)	47.34 kΩ	3.22 V
23°F (-5°C)	37.55 kΩ	2.95 V
32°F (0°C)	30 kΩ	2.67 V
41°F (5°C)	24.13 kΩ	2.40 V
50°F (10°C)	19.53 kΩ	2.14 V
59°F (15°C)	15.91 kΩ	1.89 V
68°F (20°C)	13.03 kΩ	1.66 V
77°F (25°C)	10.74 kΩ	1.45 V
86°F (30°C)	8.89 kΩ	1.27 V
95°F (35°C)	7.40 kΩ	1.10 V
104°F (40°C)	6.20 kΩ	0.96 V

# Reference

---

## 4. TEMPERATURE CHART - AMBIENT SENSOR

TEMP	RESISTANCE	VOLTAGE
-39°F (-40°C)	225.1 kΩ	4.79 V
-30°F (-35°C)	169.8 kΩ	4.72 V
-21°F (-30°C)	129.3 kΩ	4.64 V
-13°F (-25°C)	99.30 kΩ	4.54 V
-4°F (-20°C)	76.96 kΩ	4.43 V
5°F (-15°C)	60.13 kΩ	4.29 V
14°F (-10°C)	47.34 kΩ	4.13 V
23°F (-5°C)	37.55 kΩ	3.95 V
32°F (0°C)	30 kΩ	3.75 V
41°F (5°C)	24.13 kΩ	3.54 V
50°F (10°C)	19.53 kΩ	3.31 V
59°F (15°C)	15.91 kΩ	3.07 V
68°F (20°C)	13.03 kΩ	2.83 V
77°F (25°C)	10.74 kΩ	2.59 V
86°F (30°C)	8.89 kΩ	2.35 V
95°F (35°C)	7.40 kΩ	2.13 V
104°F (40°C)	6.20 kΩ	1.91 V
113°F (45°C)	5.21 kΩ	1.71 V

# Reference

## 5. How to check the Fan-Error

### (1) ~ July 2007

After sending a signal to the fan, the MICOM checks the BLDC fan motor's lock status. If there is no feedback signal from the BLDC fan, the fan motor stops for 10 seconds and then is powered again for 15 seconds. To determine that there is a fan motor malfunction, this process is repeated 5 times. If the fan motor is determined to be defective, the error code will be shown continuously in the display.

At this point, there is no further check of the fan motor.

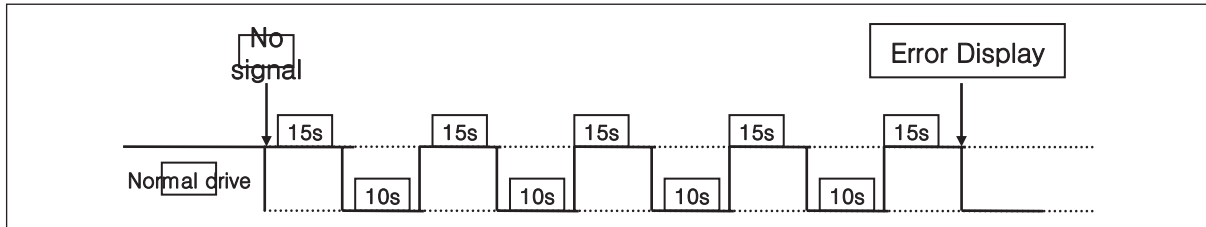

### (2) Aug 2007 ~

After sending a signal to the fan, the MICOM checks the BLDC fan motor's lock status. If there is no feedback signal from the BLDC fan, the fan motor stops for 10 seconds and then is powered again for 15 seconds. To determine that there is a fan motor malfunction, this process is repeated 3 times. If the fan motor is determined to be defective, the error code will be shown in the display for 30 minutes.

At this point, the process will be repeated until the fan motor operates normally. If normal operation is achieved, the error display is erased and the MICOM is reset automatically.

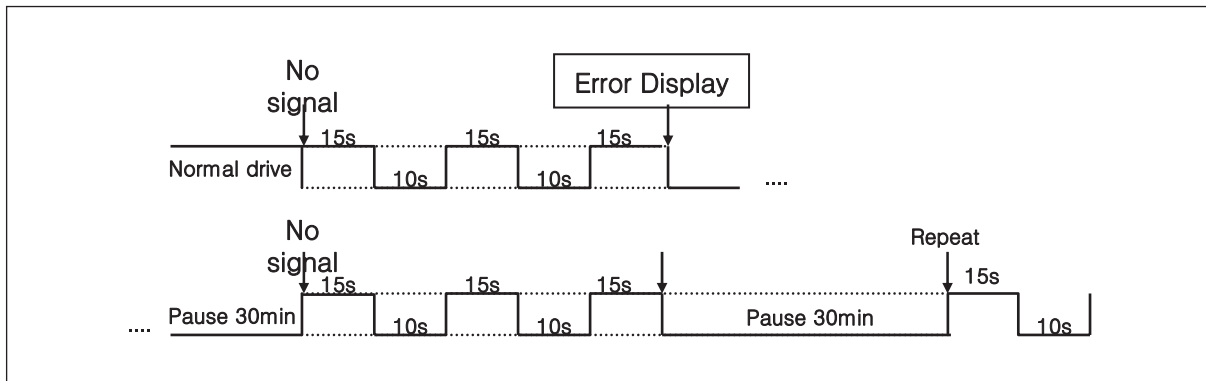



# EXPLODED VIEW

Ref. No : GBB539\*\*Q?

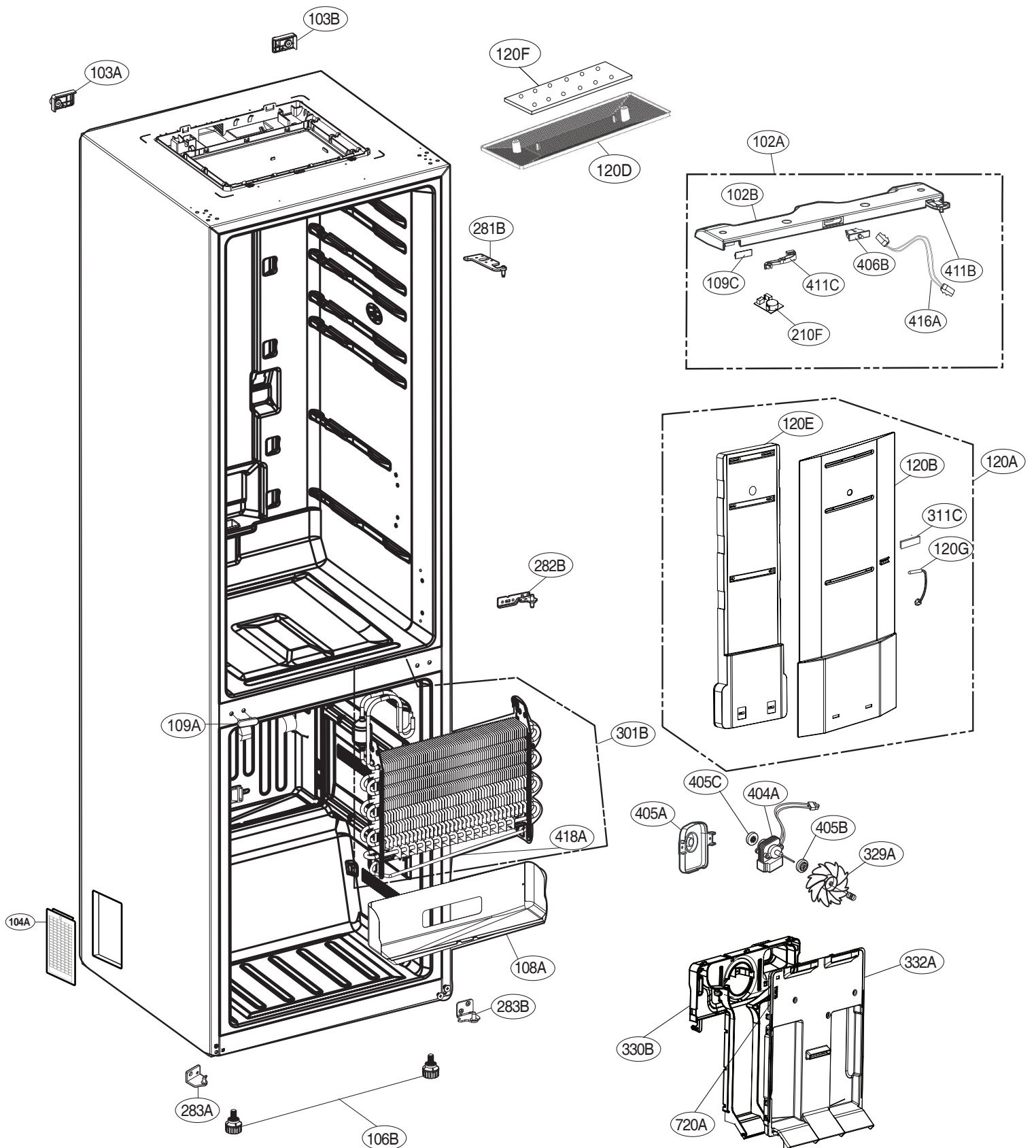

► The parts of refrigerator and the shape of each part are subject to change in different localities.

# EXPLODED VIEW

Ref. No : GBB539\*\*QMB

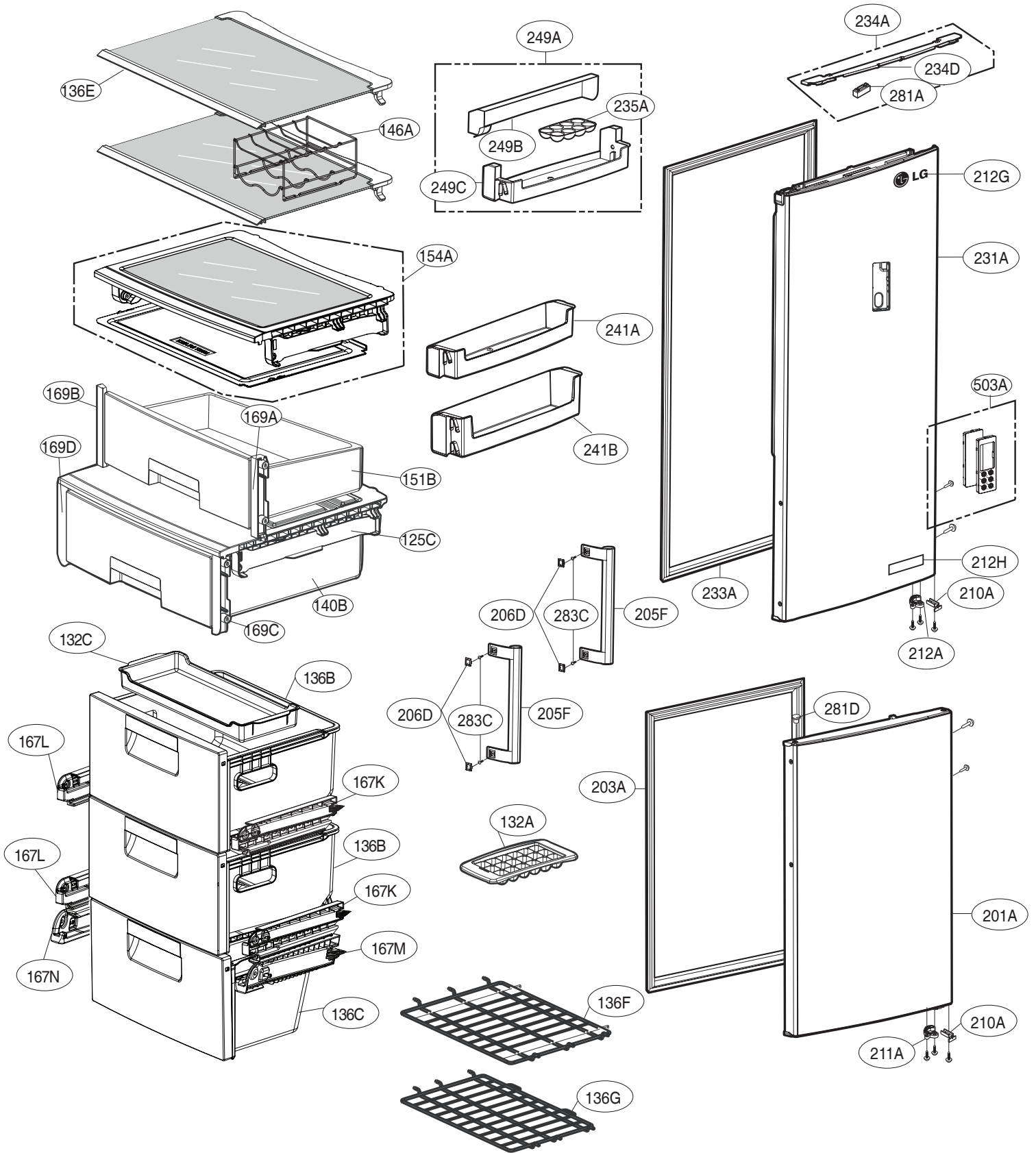

► The parts of refrigerator and the shape of each part are subject to change in different localities.

# EXPLODED VIEW

Ref. No: GBB530\*\*\*M\* GBB539\*\*\*M\*

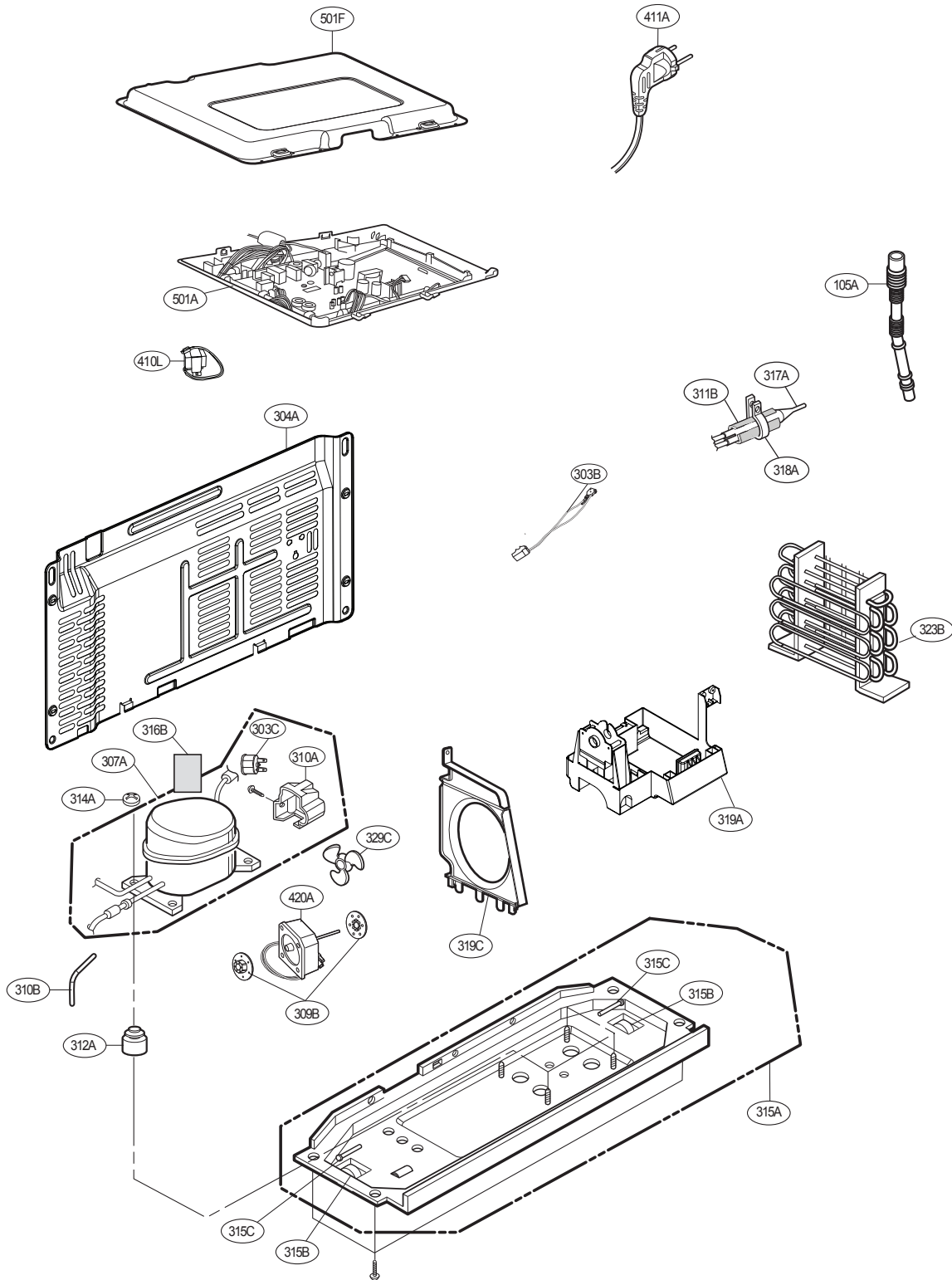

► The parts of refrigerator and the shape of each part are subject to change in different localities.



P/No. MFL67850601

FEB., 2015 Printed in Poland