

# EXPLODED VIEW - 1

REF. NO.	PART NO.	DESCRIPTION
A	87-067-703-010	BVT2 + 3 - 10 W/O SLOT
B	87-591-094-410	QIT + 3 - 6
C	87-067-584-010	BVT2 + 3 - 6 W/O SLOT
D	87-067-641-010	UTT2 + 3 - 8 W/O SLOT [B]

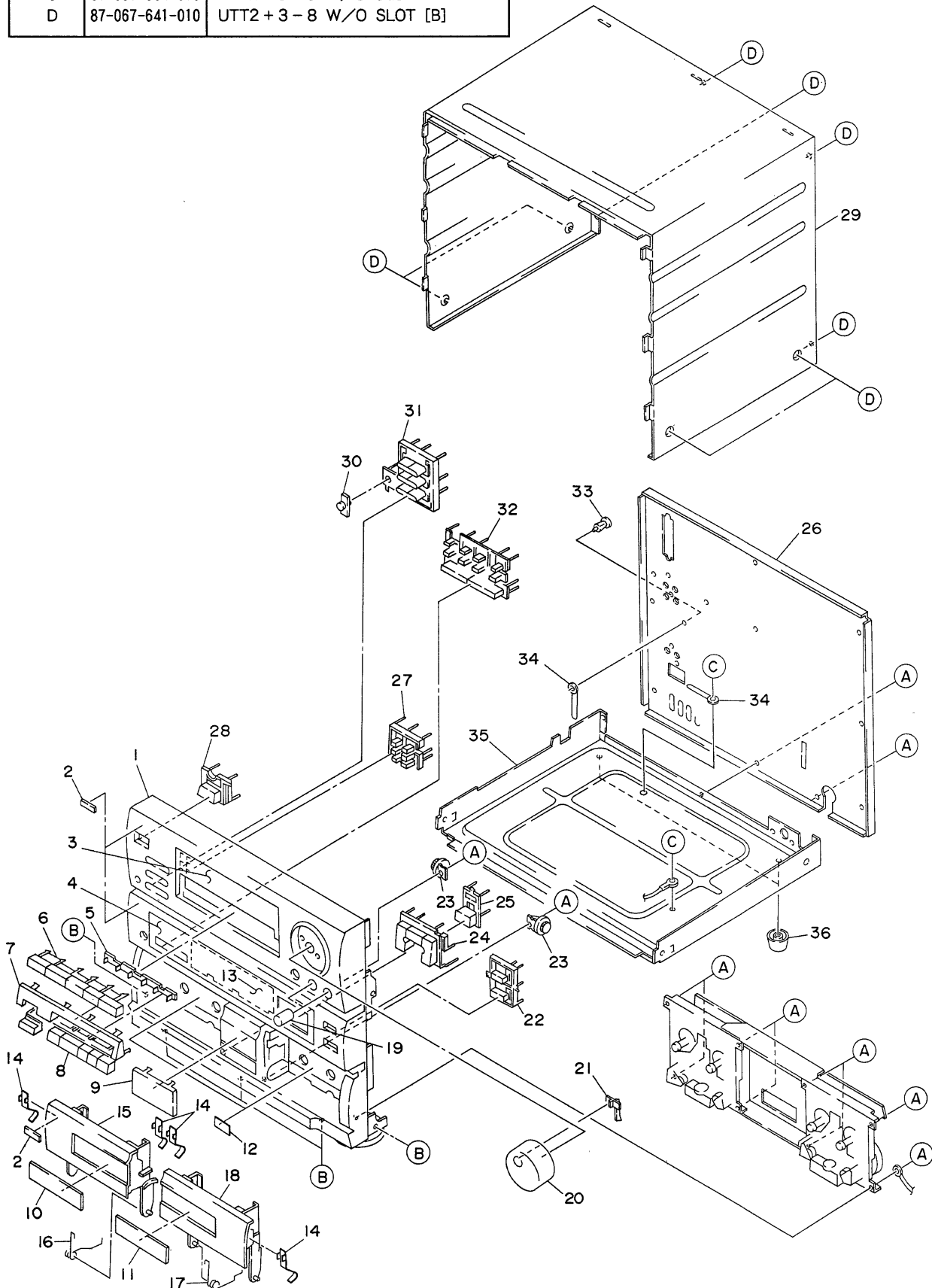

# EXPLODED VIEW - 2

REF. NO.	PART NO.	DESCRIPTION
A	87-067-703-010	BVT2 + 3 - 10 W/O SLOT
B	81-MK1-210-010	S - SCREW BFT2 + 3 - 16
C	87-067-579-010	BVT2 + 3 - 8 W/O SLOT
D	87-067-633-010	BVT2 + 3 - 8 W/CONVEX
E	87-067-698-010	BVT2 + 3 - 18 W/O SLOT (E)
F	87-067-584-010	BVT2 + 3 - 6 W/O SLOT
G	87-591-094-410	QIT + 3 - 6
H	87-067-585-010	BVTT + 4 - 6
I	87-081-808-019	PW1.7 - 3.5 - 0.25
J	87-067-058-019	FW 3.2 - 8 - 0.5
K	87-067-581-019	BVT2 + 3 - 15 W/O SLOT (H)

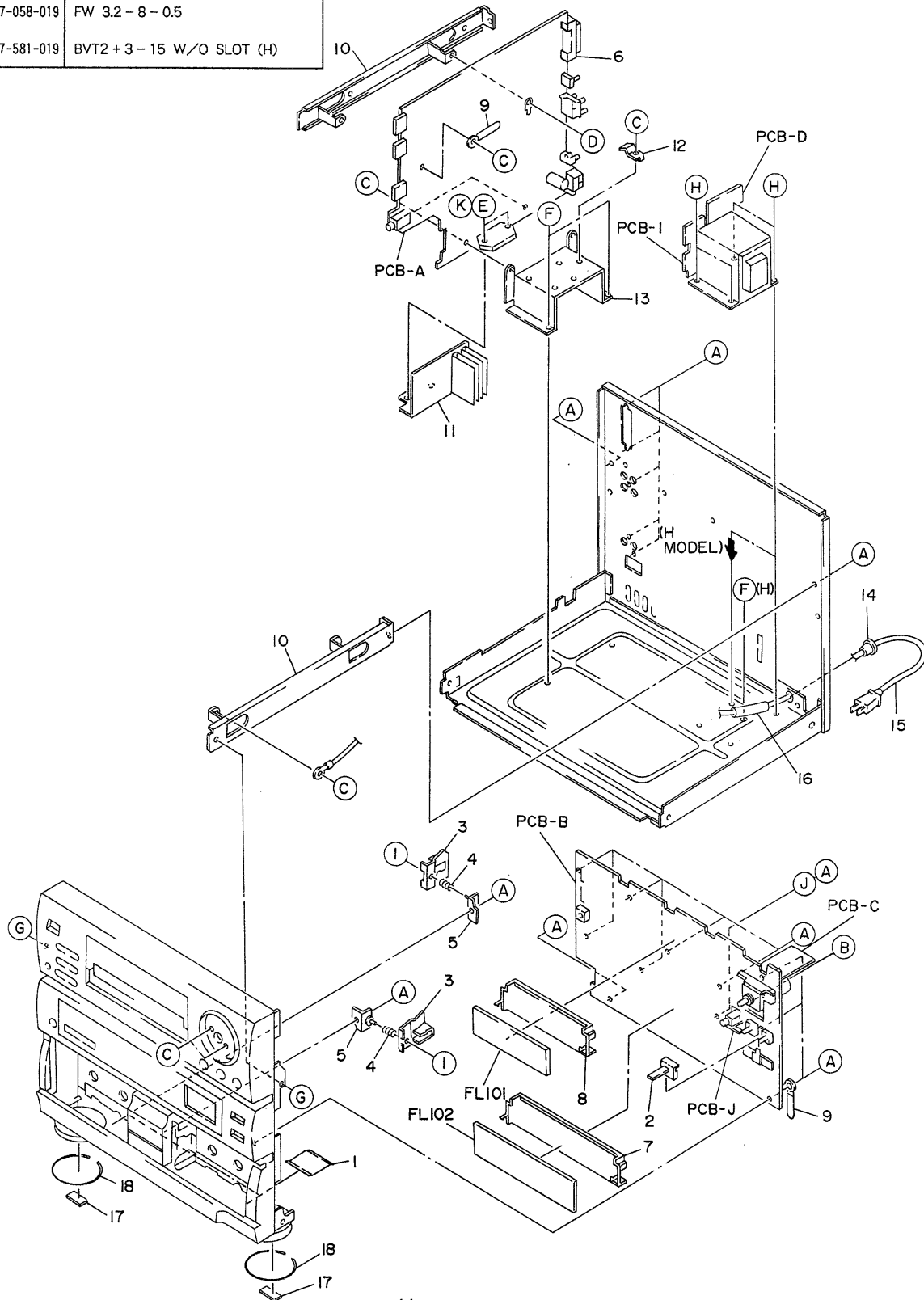

# EXPLODED VIEW - 3

REF. NO.	PART NO.	DESCRIPTION
A	87-263-033-119	V + 2 - 4
B	80-ZM6-251-019	S - SCREW AZIMUTH 2
C	86-524-418-019	SCREW VFT2 + 1.4 - 5
D	87-067-825-010	PW4.1 - 6.9 - 0.25
E	87-067-174-019	SCREW VTT + 2 - 4
F	80-ZM6-207-019	V + 1.6 - 7
G	86-575-363-210	S - SCREW V + 2 - 8

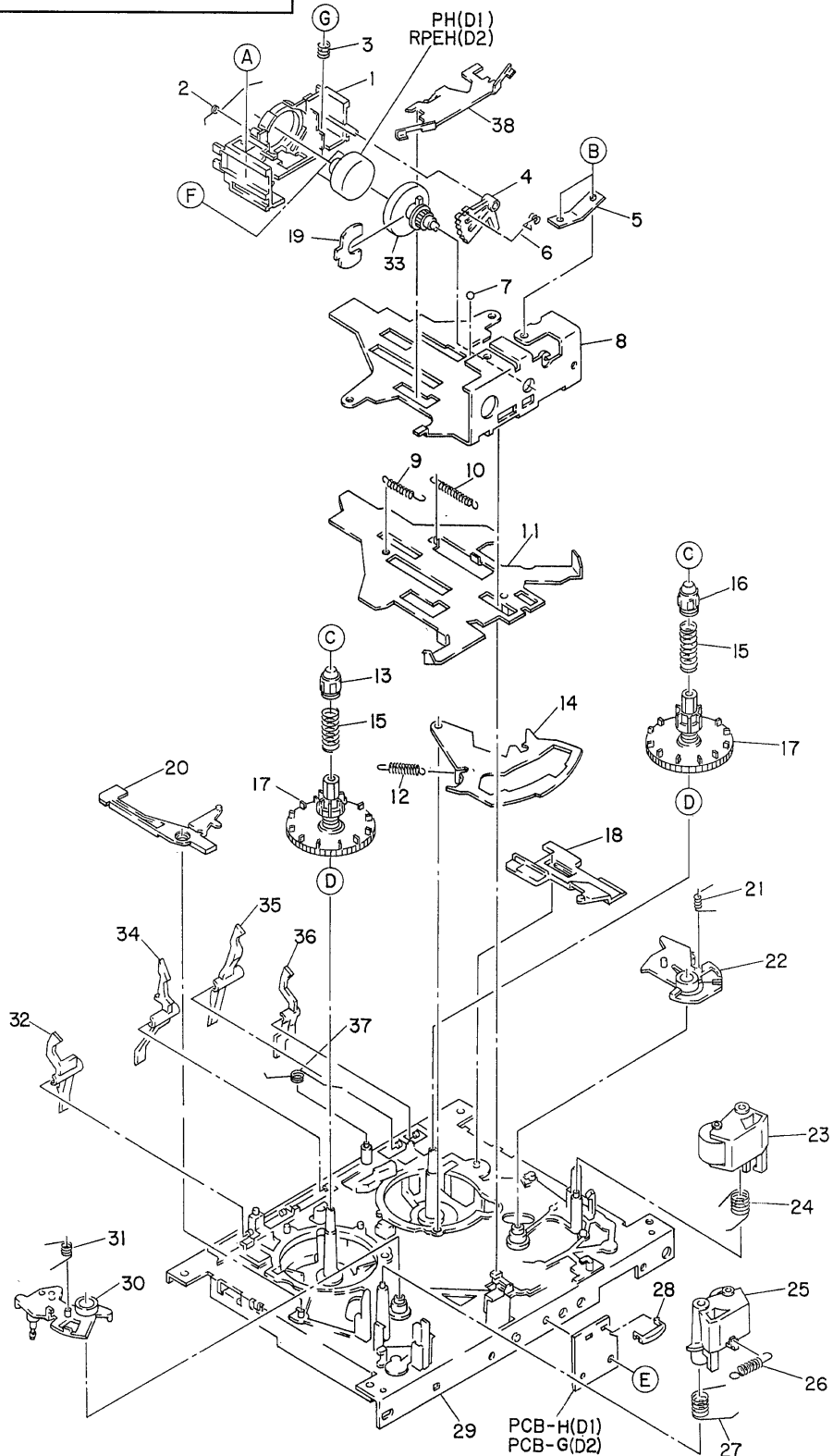

# EXPLODED VIEW - 4

REF. NO.	PART NO.	DESCRIPTION
A	87-067-178-010	VTT + 2.6 - 3
B	86-524-457-019	SCREW U + 2.6 - 5.5
C	80-ZM6-216-010	PW1.57 - 4 - 0.25 SLT
D	87-081-489-019	PW1.7 - 3.5 - 0.25 SLT
E	87-067-380-019	PW1.7 - 7 - 0.5
F	80-ZM6-249-010	PW2.1 - 5 - 0.13
G	80-ZM6-211-019	PW2.68 - 4.15 - 0.3 SLT
H	80-ZM6-252-010	VTT + 2.6 - 3

