

| | | | | |
|---|--------------------------|--------|-------|--|
| | | | | |
| | | | | |
| | | | | |
| | | | | |
| | | | | |
| | | | | |
| R | Date/Tarih | Rev No | | |
| | Main Body Gövde Grubu | | Çizen | |
| | 17 9981 7086 | | Onay | |

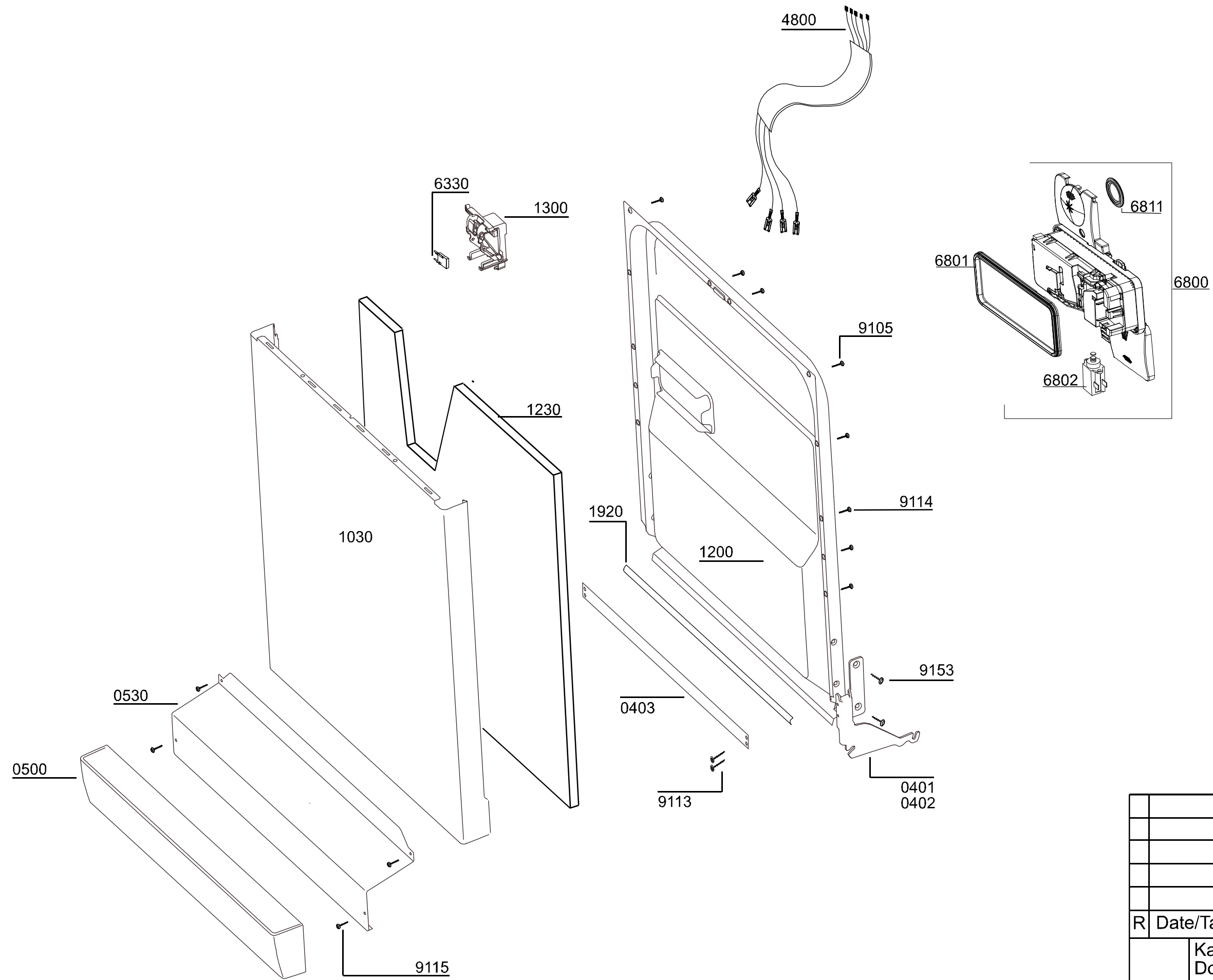

| | | | |
|---|----------------------|--------|--|
| | | | |
| | | | |
| | | | |
| | | | |
| R | Date/Tarih | Rev No | |
| | Kapi gr. Door gr. | | |
| | 17 9983 7006 | | |

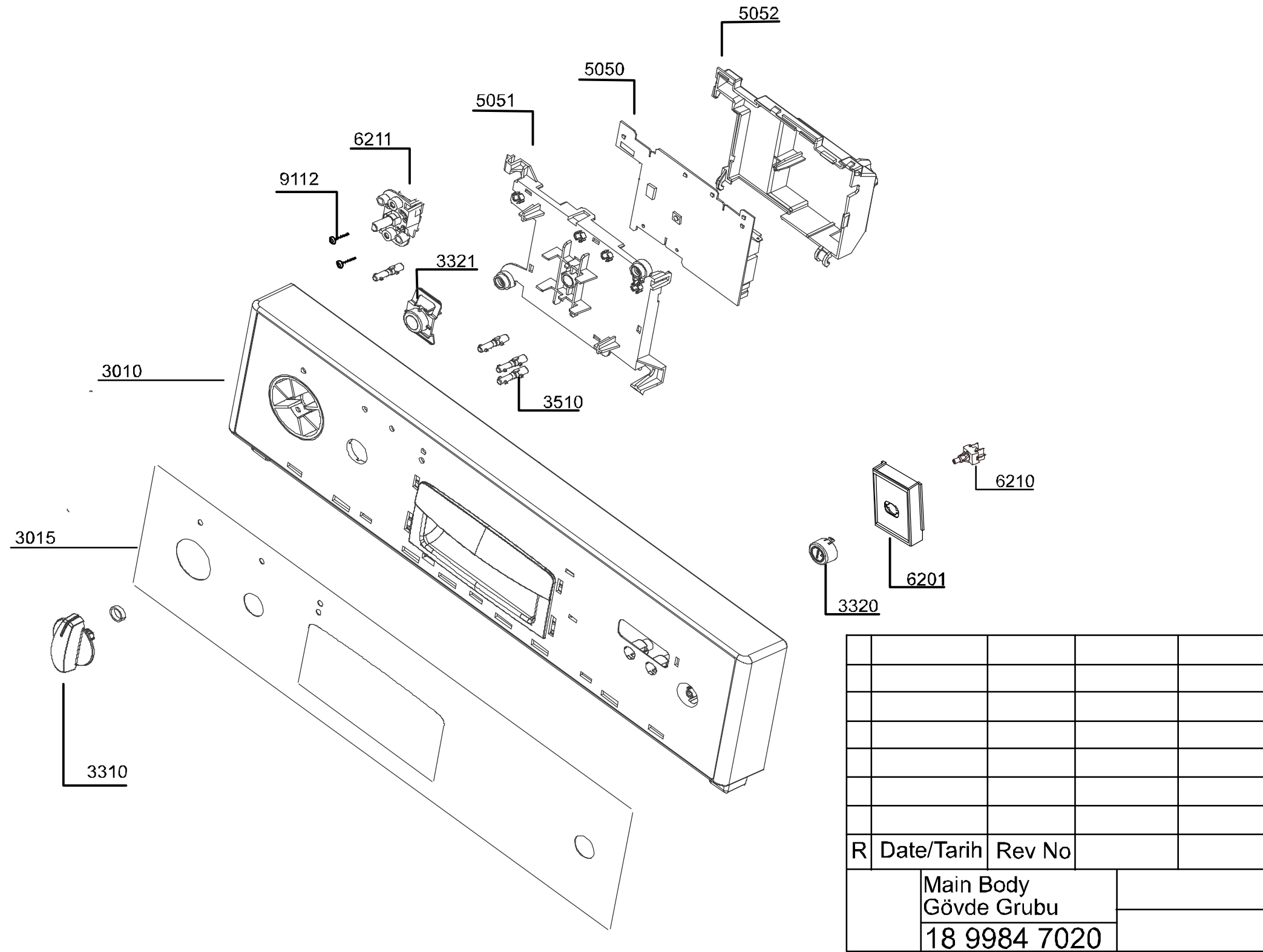

| | | | | |
|--------------|------------|--------|--|--|
| | | | | |
| | | | | |
| | | | | |
| | | | | |
| | | | | |
| | | | | |
| | | | | |
| R | Date/Tarih | Rev No | | |
| Main Body | | | | |
| Gövde Grubu | | | | |
| 18 9984 7020 | | | | |