

- **Manual de instrucciones.**
- **Manual de instruções.**
- **Mode d'emploi.**
- **Operating instructions.**
- **Bedienungsanleitung.**
- **Manuale di istruzioni.**

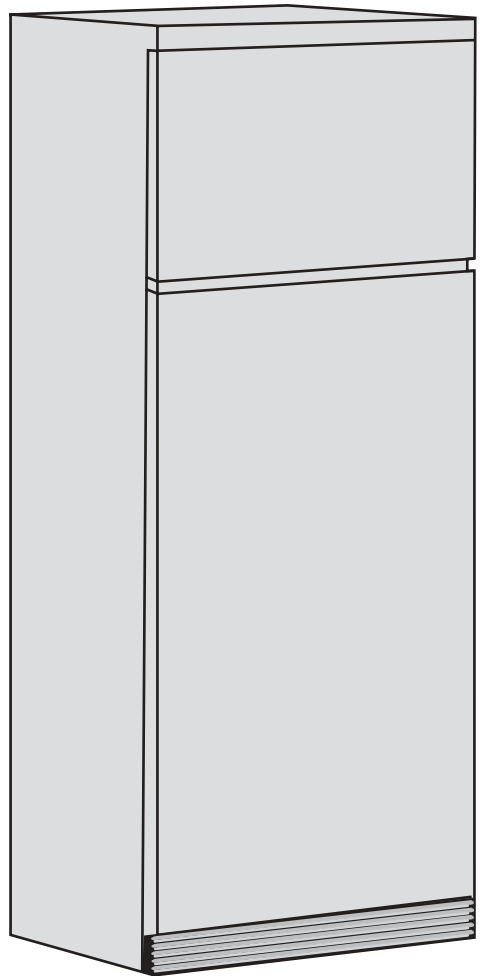

INDICE

	Pag.
Instalación.....	2
Descripción general	3
Utilización del refrigerador.....	4
Utilización del congelador	6
Limpieza y mantenimiento	10
Cambio de sentido de apertura de puertas	11
Panelación (Sólo modelos P/PB)	13
Problemas de funcionamiento	14
Esquema eléctrico	15
Especificaciones	15

ADVERTENCIA

Si su antiguo frigorífico dispone de pestillos de cierre automático o manual, **NO OLVIDE DESTRUIR O INUTILIZAR EL SISTEMA DE CIERRE** antes de echarlo a la chatarra. Con ello evitará que los niños al jugar puedan quedar encerrados dentro.

NO DAÑE LAS TUBERIAS y evitará el escape incontrolado de refrigerante a la atmósfera.

INSTALACION

RECOMENDACIONES

Permitir la circulación de aire por la parte trasera del frigorífico.
No taponar la rejilla delantera ni el techo del frigorífico con ningún objeto.
Si se instala un armario encima, tendrá un hueco para que el aire circule.

Evitar en lo posible la proximidad de fuentes de calor.

Si necesita tumbar el frigorífico para desembalarlo o cambiar el sentido de giro de las puertas, **SOLO SE PUEDE TUMBAR SOBRE LA PARTE TRASERA.**

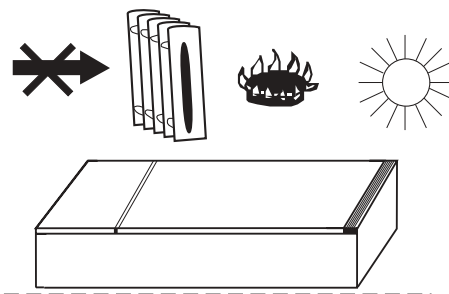

NOTA: Las bisagras de las puertas están en el lado derecho. Si esta disposición es incómoda para usted, es posible cambiar de lado las bisagras. En el anexo CAMBIO DE SENTIDO DE APERTURA DE PUERTAS están las instrucciones.

Regulando los pies de nivelación comprobar que el frigorífico queda bien apoyado en el suelo (sin cojear) y bien nivelado (no ladeado).
IMPORTANTE

Este frigorífico funciona a 220/230v. Si Vd. dispone de una tensión diferente en su hogar, debe utilizar un transformador de potencia no inferior a 700W.

Utilice un enchufe con TOMA DE TIERRA.

NOTA: El fabricante declina toda responsabilidad en caso de que no se sigan estas recomendaciones.

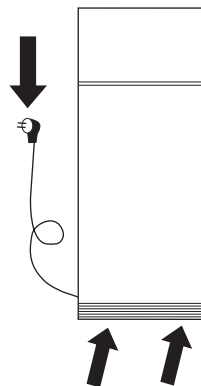

ATENCION ANTES DE CONECTAR

1.- Limpiar el interior del frigorífico.



2.- Para un correcto funcionamiento, esperar 2 horas antes de conectar.



3.- Conectar.



DESCRIPCION GENERAL

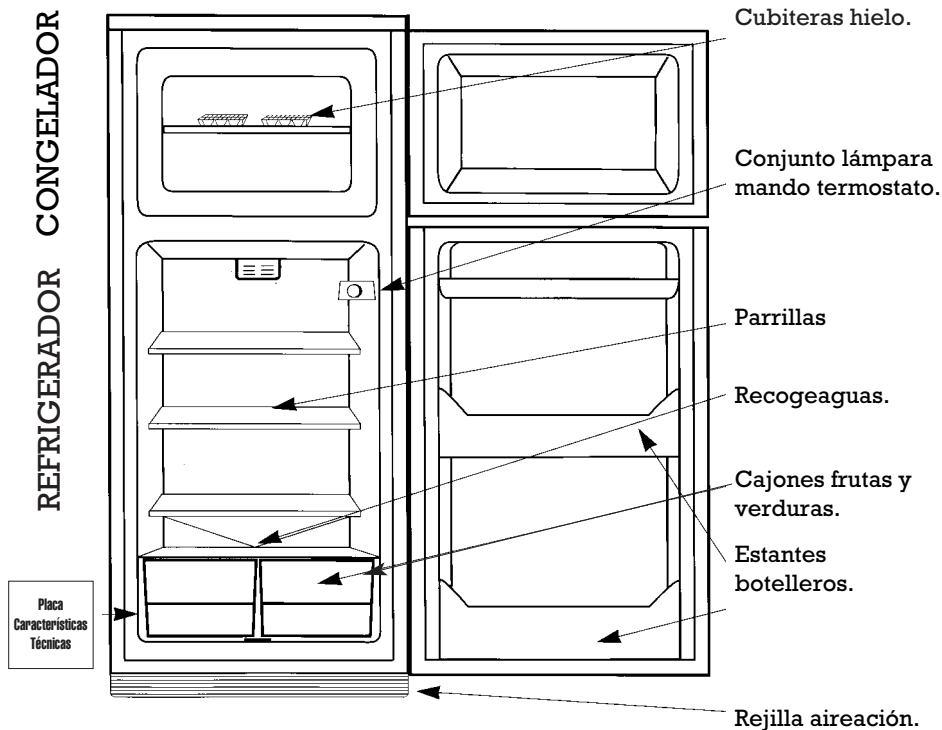

PUESTA EN FUNCIONAMIENTO

1 Accione el mando termostato seleccionando una posición media.

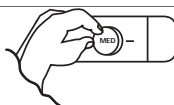

2 Cierre las puertas.

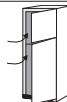

3 Pasadas 3 horas, puede introducir alimentos en el refrigerador. Para congelar alimentos frescos, espere 24 horas*

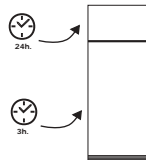

UTILIZACION DEL REFRIGERADOR

ALIMENTOS

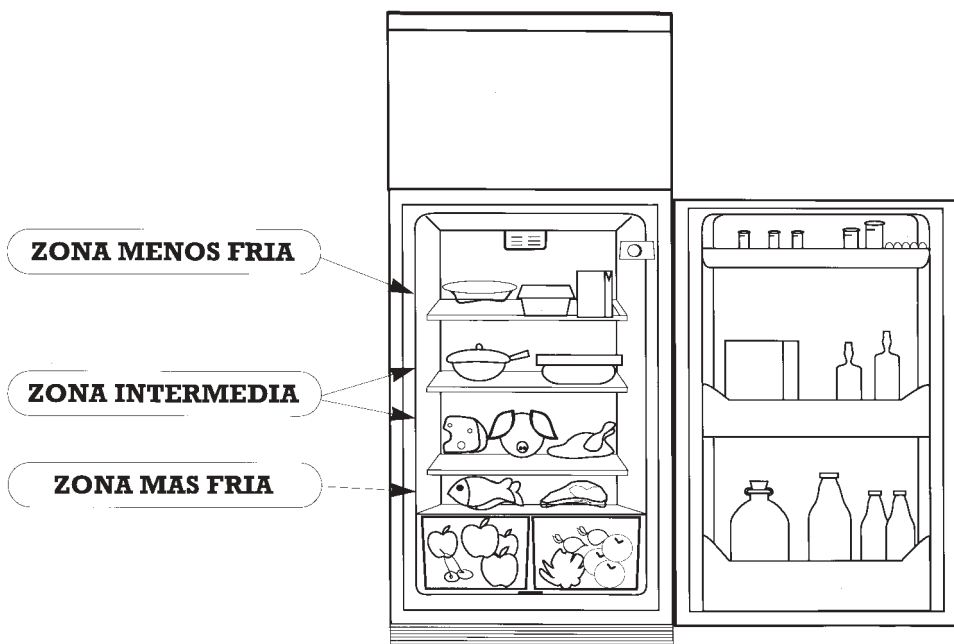

ATENCIÓN

- Girando el mando termostato se puede seleccionar más o menos frío en el refrigerador.
- Hay que tener en cuenta que la temperatura no es totalmente uniforme en todo el recinto, por lo que hay zonas adecuadas para cada tipo de alimento (según figura).
- La temperatura en el refrigerador puede verse afectada por la temperatura ambiente, la ubicación del aparato y la frecuencia de apertura de la puerta. Cuando la temperatura ambiente es muy alta, obtendrá el mejor rendimiento con el termostato en posición media.
- No introducir en el refrigerador alimentos calientes o líquidos sin taponar.
- No introducir NUNCA líquidos volátiles, inflamables o explosivos, como disolventes, alcoholes, acetona o gasolina. Hay riesgo de explosión.
- Las carnes y pescados es conveniente envolverlos para evitar olores.

UTILIZACION DEL REFRIGERADOR

DESHIELO

El sistema de deshielo del refrigerador funciona automáticamente, por tanto no necesita ninguna intervención del usuario.

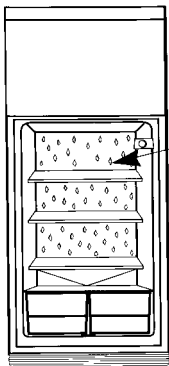

La pared del fondo del refrigerador estará habitualmente llena de gotitas de agua o hielo. Esto es totalmente NORMAL y forma parte del proceso automático de deshielo.

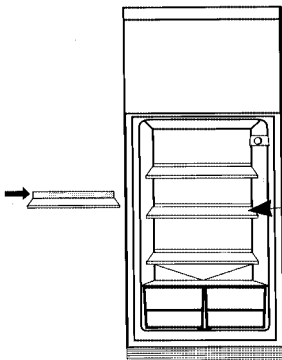

Procure que los alimentos no toquen la pared del fondo. Para ello las parrillas disponen de un tope que no se debe sobrepasar.

UTILIZACION DEL CONGELADOR

CONGELACION ALIMENTOS FRESCOS

NOTA

El congelador de este frigorífico tiene categoría de 4 * *** estrellas y es capaz de congelar hasta 4 kg. de alimentos frescos en 24 horas.

CONSEJOS

- Envuelva los productos a congelar en papel aluminio o recipientes herméticos.
- Prepare los alimentos en raciones consumibles de una sola vez.
- Nunca congele por segunda vez un alimento descongelado.
- Coloque una etiqueta en el envoltorio indicando el contenido y la fecha de congelación.
- No ponga en contacto directo los alimentos a congelar con los ya congelados.
- No almacene en el congelador bebidas gaseosas.
- Los helados no deben consumirse demasiado fríos.

UTILIZACION DEL CONGELADOR

CONSERVACION DE ALIMENTOS CONGELADOS

CONSEJOS

- Cuando adquiera alimentos congelados en el comercio, procure que transcurra el menor tiempo posible hasta su introducción en el congelador.
- Preste atención al tiempo de conservación marcado en los envases de los productos congelados, teniendo en cuenta que este congelador es de categoría 4 estrellas. ★ ★★★
- Para los alimentos congelados por usted, consulte la tabla de tiempos de conservación

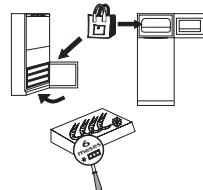

TIEMPOS DE CONSERVACION

TIPO DE ALIMENTO	Número Meses
PESCADOS Y MARISCOS	
Langosta-Crustáceos	3
Gambas-Langostinos	3
Merluza	2
Pescados grasos	3/4
Trucha	2/3
Salmón	2/3
Lenguado	3
Rodaballo	2/3
CARNE	
Vacuno mayor	10/12
Cordero	6/8
Ternera	9
Cerdo	6
Filetes/Chuletas	4
Higado/Riñones	10
Seso/Lengua	2
Carne picada, Salchichas	2
Conejo	5/7
AVES Y CAZA	
Gallinas-Pollos	10
Pavo- (troceado)	7
Pato, Ganso, Oca	5
Liebre	6
Perdiz-Codorniz	8
Faisán	7/8
Caza Mayor	10
PLATOS PREPARADOS	
Salsa de tomate	3
Caldo de Carne	3
Asados: buey, ternera, pollo, cerdo	2/3
Menestra de verduras	3
Carne cocida, Estofado	3
Hamburguesas	2
Pimientos rellenos	2
Espinacas	2
Judías verdes y salteadas	2
Tartas empanadas, etc.	5/6
Macedonia de frutas	3
Sandwiches	6

TIPO DE ALIMENTO	Número Meses
HORTALIZAS	
Ácelgas	12
Alcachofas	12
Zanahorias	12
Coliflor	6/8
Coles de Bruselas	6
Espárragos	12
Berza	6/8
Judías	12
Setas	6
Perejil	12
Pimientos	12
Espinacas	12
Habas	12
FRUTAS	
Albaricoque	8
Cerezas, ciruelas, frambuesas, grosellas, moras	10
Melocotón	10/12
Fresas	12
Compotas (manzanas, peras)	10
Uva	10/12
Zumos fruta	10
Piña	10/12
PAN Y PASTELERIA	
Bizcochos-Tartas	6
Tarta hojaldre	1
Masa de pastelería	3
Pan y bollería	2
HUEVOS, LECHE Y DERIVADOS	
Huevos (quitada la cáscara)	6
Leche homogeneizada (envase de cartón)	3
Mantequilla	6
Quesos (pequeñas porciones)	6/8
Nata fresca	3

UTILIZACION DEL CONGELADOR

DESCONGELACION DE ALIMENTOS

No todos los alimentos deben ser descongelados de la misma forma.

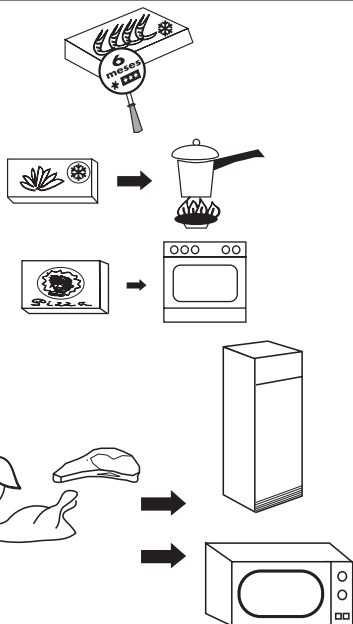

Si adquirió el alimento congelado en el comercio, siga las instrucciones del envase.

Las verduras deben cocinarse directamente.

En general, los alimentos preparados o precocinados pueden cocinarse directamente.

Carnes y pescados han de descongelarse lentamente en el refrigerador durante varias horas. Si usted dispone de horno microondas, podrá acelerar el descongelo en gran medida.

PRODUCCION DE CUBITOS DE HIELO

1 Llene hasta las tres cuartas partes de agua las bandejas que encontrará en el interior del congelador.



2 Introduzca las bandejas en el congelador, preferiblemente en la parte inferior.

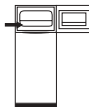

3 Una vez congelada el agua, puede desmoldear los cubitos retorciendo ligeramente las bandejas.

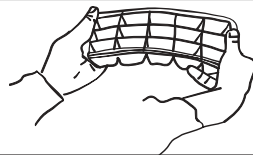

DESHELO Y LIMPIEZA

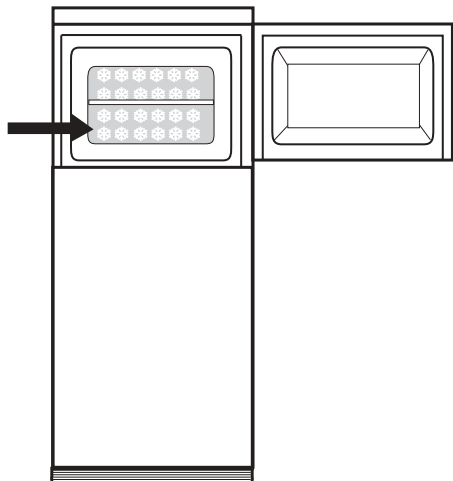

Con el tiempo, en las paredes del congelador se va formando una capa de escarcha o hielo.

Esto provocará un mayor consumo de energía en su frigorífico.

Para evitarlo, hay que eliminar esta capa de hielo, al menos 2 veces al año.

- 1 Coloque el mando termostato en la posición de STOP y el frigorífico quedará desconectado.



- 2 Puede ayudar a eliminar el hielo mediante una paleta o introduciendo un recipiente con agua caliente. No utilice objetos afilados ni aparatos de calentamiento eléctricos.

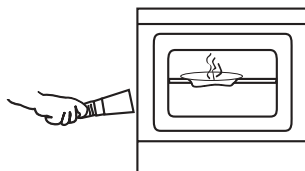

- 3 Recoja el agua de deshielo con una bayeta absorbente, limpie y seque bien el interior.

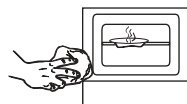

- 4 Accione el mando termostato a la posición habitual de funcionamiento.

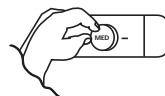

- 5 2 horas más tarde puede volver a introducir los alimentos congelados en el congelador.

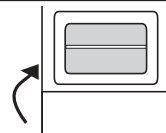

LIMPIEZA Y MANTENIMIENTO

LIMPIEZA

CONSEJOS

Para la limpieza del interior el frigorífico debe estar desconectado.

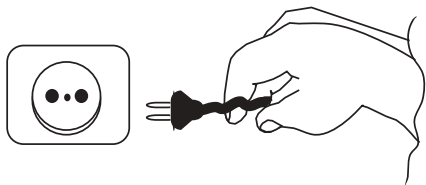

No utilice productos abrasivos disolventes, limpiadores de metales o detergentes no diluidos.



Es conveniente limpiar una vez al año con una aspiradora la rejilla de la parte trasera del frigorífico. La suciedad perjudica el funcionamiento y aumenta el consumo de energía eléctrica.

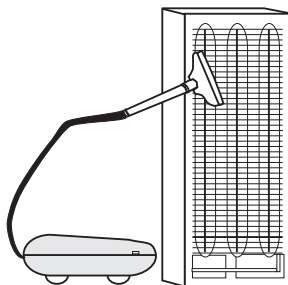

PARADA TEMPORAL DEL FRIGORIFICO

- Desconecte el frigorífico
- Retire los alimentos, limpie y seque el interior.
- Deje la puerta abierta para evitar la formación de malos olores.
- Haga lo mismo en caso de corte de corriente prolongado o fallo del frigorífico.

CAMBIO DE LAMPARA

1- Desconectar el frigorífico.



2- Extraer la lámpara estropeada y reponerla con otra del mismo tipo



CAMBIO DE SENTIDO DE APERTURA DE PUERTAS

- 1** Tumbe el frigorífico sobre la parte trasera.

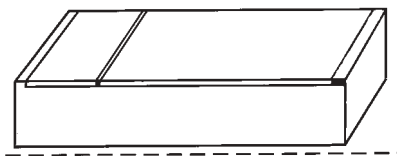

- 2** Si su frigorífico lleva zócalo inferior extraígalo tal como se indica en la figura. Seguidamente, rasgue la parte izquierda marcada del zócalo para olajar la bisagra inferior según figura.

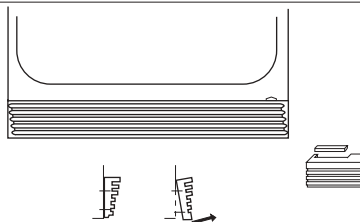

- 3** Extraiga la bisagra inferior soltando los 3 tornillos de sujeción (A). Suelte el eje (B) de la posición derecha y móntelo en la posición izquierda de la bisagra. Suelte los 2 tornillos (C) y atorníllelos en el lado derecho. Retire la puerta inferior.

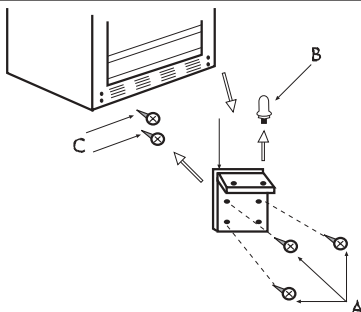

- 4** Extraiga la bisagra intermedia retirando la plaquita protectora que oculta los tornillos y soltándolos. Extraiga también la tapita del lado izquierdo y colóquela donde estaba la bisagra. Retire la puerta superior.

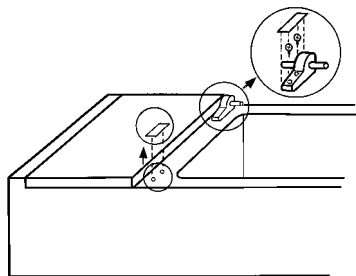

- 5** Extraiga el eje (D) de la posición derecha y móntelo en la posición izquierda.

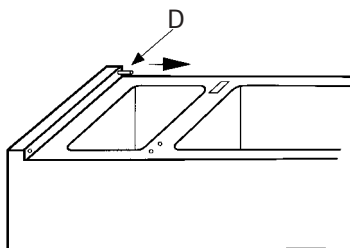

- 6** Quite el tapón del eje izquierdo de las puertas y póngalo en el eje derecho (los modelos panelables no llevan este tapón).

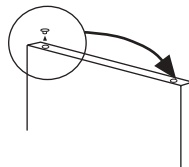

- 7** Coloque la puerta superior introduciéndola en el eje situado en lado izquierdo

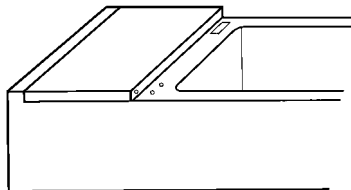

- 8** Introduzca la bisagra intermedia en el eje izquierdo de la puerta superior y atornillela al frigorífico. Coloque la puerta inferior introduciéndola en el eje de la bisagra intermedia. A continuación coloque la plaquita protectora que oculta los tornillos de sujeción

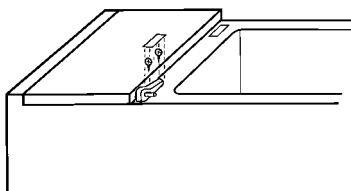

- 9** Introduzca la bisagra inferior en el lateral izquierdo, y átela con los 3 tornillos.

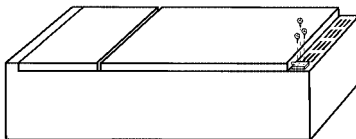

- 10** Vuelva a colocar el zócalo inferior en su posición.

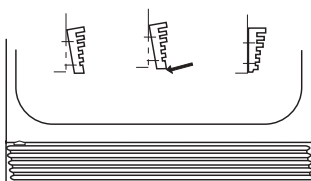

- 11** Si su frigorífico es panelable deberá cambiar de lado los tiradores de las puertas

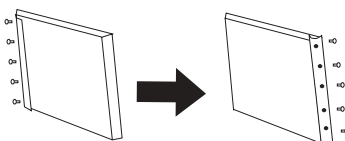

Si su frigorífico es un modelo panelable y desea asemejar el aspecto exterior de su frigorífico al resto del mobiliario de su cocina, puede revestir las puertas con paneles siguiendo estas instrucciones.

- 1** Dimensiones del mueble frigorífico y de los paneles de puertas.
(Espesor de paneles menor de 4mm).

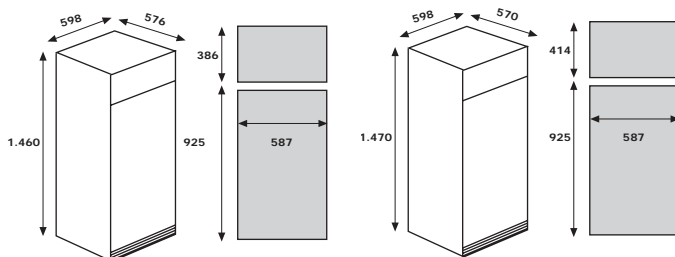

- 2** Extraiga el tirador y/o el marco del lado izquierdo de la puerta soltando los correspondientes tornillos.

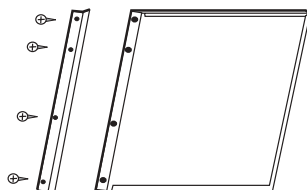

- 3** Afloje el resto de tornillos del contorno de la puerta sacando los marcos como indica la figura, e introduzca el panel deslizándolo.

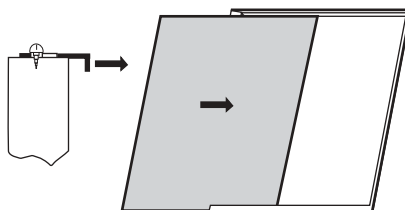

- 4** Apriete el reborde del marco contra el panel y sujete los tornillos del marco en esa posición. Coloque el marco y/o el tirador con sus tornillos.

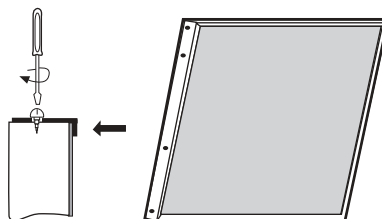

PROBLEMAS DE FUNCIONAMIENTO

PROBLEMA	CAUSA POSIBLE	SOLUCION
El frigorífico no funciona	El enchufe no está conectado a la toma de corriente.	Conectar enchufe.
	No llega corriente eléctrica al enchufe por haberse fundido el fusible o por haber saltado el limitador automático de potencia.	Cambiar fusible o volver a conectar el limitador automático de potencia.
El refrigerador enfría poco	El mando termostato se encuentra en una posición baja.	Gire el mando termostato a una posición de más frío.
	Se ha dejado la puerta mal cerrada o se ha abierto con mucha frecuencia.	Cuidar que la puerta no permanezca abierta mucho tiempo.
	Se ha obstaculizado la rejilla de aireación o la abertura de la parte posterior del techo.	Conservar libres estas zonas según se indica en el capítulo "Instalación" de este manual.
	El frigorífico está expuesto directamente a los rayos de sol o a una fuente de calor.	Cambiar la ubicación del frigorífico o protegerlo de esas fuentes de calor.
Gotas de agua en la pared del fondo del refrigerador	Ciclo automático de deshielo.	No se alarme: esto es completamente normal (ver capítulo "Utilización del refrigerador" de este manual).
Aparece agua en la base del refrigerador	Se ha colocado algún alimento o recipiente pegado a la pared del fondo del refrigerador.	No ponga alimentos o recipientes en contacto con la pared del fondo y evitara el derrame del agua de deshielo.
Mucho hielo en las paredes y estantes del congelador	La puerta congelador no cierra bien por estar obstaculizada.	Procure un buen cierre de las puertas manteniéndolas libres de objetos o suciedad.
La lámpara del refrigerador no enciende	El enchufe no está conectado a la toma de corriente.	Conectar enchufe.
	No llega corriente eléctrica al enchufe por haberse fundido el fusible o por haber saltado el limitador automático de potencia.	Cambiar fusible o volver a conectar el limitador automático de potencia.
	La lámpara está floja.	Enroscar correctamente.
	La lámpara está fundida.	Cambiar la lámpara según se indica en este manual.
Funcionamiento ruidoso	El frigorífico no ha sido nivelado correctamente.	Nivelar según se indica en el capítulo "Instalación" de este manual.
Ruido de borboteo	Ciclo funcionamiento.	No se alarme, esto es completamente normal.
Los alimentos se secan	Los alimentos no están envueltos o tapados.	Envolverlos o introducirlos en recipientes herméticos.
Olores en el interior	Algún alimento no está correctamente envuelto o tapado.	Envolverlo o introducirlo en un recipiente hermético.
	El interior del aparato necesita una limpieza.	Limpiar según se indica en este manual.

SERVICIO DE ASISTENCIA TECNICA

Si Vd. ya ha realizado las comprobaciones indicadas y su problema persiste, NO EFECTUE NINGUNA OTRA REPARACION VD. MISMO. Pongase en contacto con el Servicio de Asistencia Técnica más proximo.

ESPECIFICACIONES

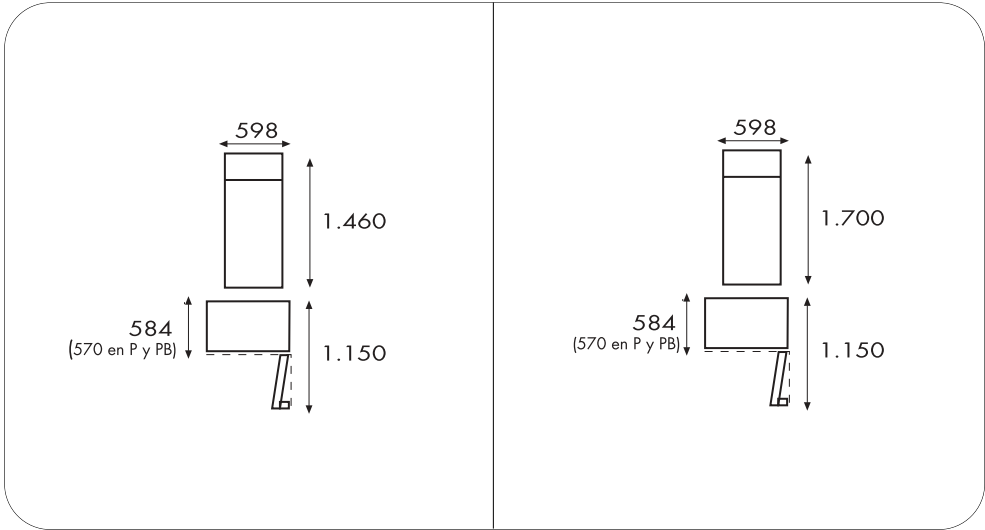

CE ESTOS APARATOS CUMPLEN CON LAS DIRECTIVAS CEE: 73/23, 93/68, 89/336

INDICE

	Pag.
Instalação	2
Descrição geral.....	3
Utilização do refrigerador	4
Utilização do congelador	6
Limpeza e manutenção	10
Mudança de sentido de abertura das portas.....	11
Revestimento de painéis (só os modelos P/PB) ...	13
Problemas de funcionamento	14
Esquema eléctrico	15
Especificações	15

ADVERTÊNCIA

Se o vosso antigo frigorífico dispõe de ferrolho de fechamento automático ou manual, **NÃO ESQUEÇA DE DESTRUIR OU INUTILIZAR O SISTEMA DE FECHAMENTO** antes de jogá-lo no ferro-velho. Com isto evitará que os miúdos ao brincarem possam ficar trancados dentro. **NÃO ESTRAGUE AS TUBAGENS** e evitará o escapeamento incontrolado de refrigerante na atmosfera.

INSTALAÇÃO

RECOMENDAÇÕES

Permitir a circulação do ar pela parte posterior do frigorífico. Não tampar a grade da frente nem o tecto do frigorífico com nenhum objecto. Se for instalado um armário encima, deve ter um ôco para que circule o ar.

Evitar dentro do possível a proximidade de fontes de calor.

Se necessitar deitar o frigorífico para ser desembalado ou mudar o sentido de giro das portas, **SOMENTE SE PODE DEITAR SOBRE A PARTE POSTERIOR.**

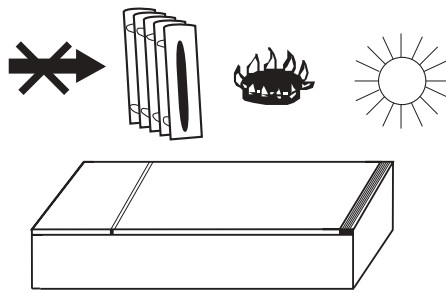

NOTA: As dobradiças das portas estão no lado direito. Se esta posição é incomoda para Vovê, é possível mudar de lado as dobradiças. No anexo **MUDANÇA DE SENTIDO DE ABERTURA DAS PORTAS** estão as instruções.

IMPORTANTE: Regulando os pés de nivelamento, comprovar que o frigorífico fique bem apoiado no chão (sem mancar) e bem nivelado (não de lado).

Este frigorífico funciona a 220/230v. Se Você dispõe duma tensão diferente na vossa casa, deve utilizar um transformador de potência não inferior a 700 W.

Utilize uma tomada com **TOMA DE TERRA.**

NOTA: O fabricante declina de toda responsabilidade no caso de que não sejam seguidas estas recomendações.

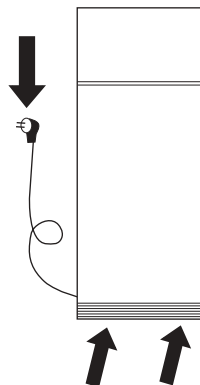

ATENÇÃO ANTES DE LIGAR

1.- Limpar o interior do frigorífico.



2.- Para un correcto funcionamiento, esperar 2 horas antes de ligar.



3.- Ligar.



DESCRIÇÃO GERAL

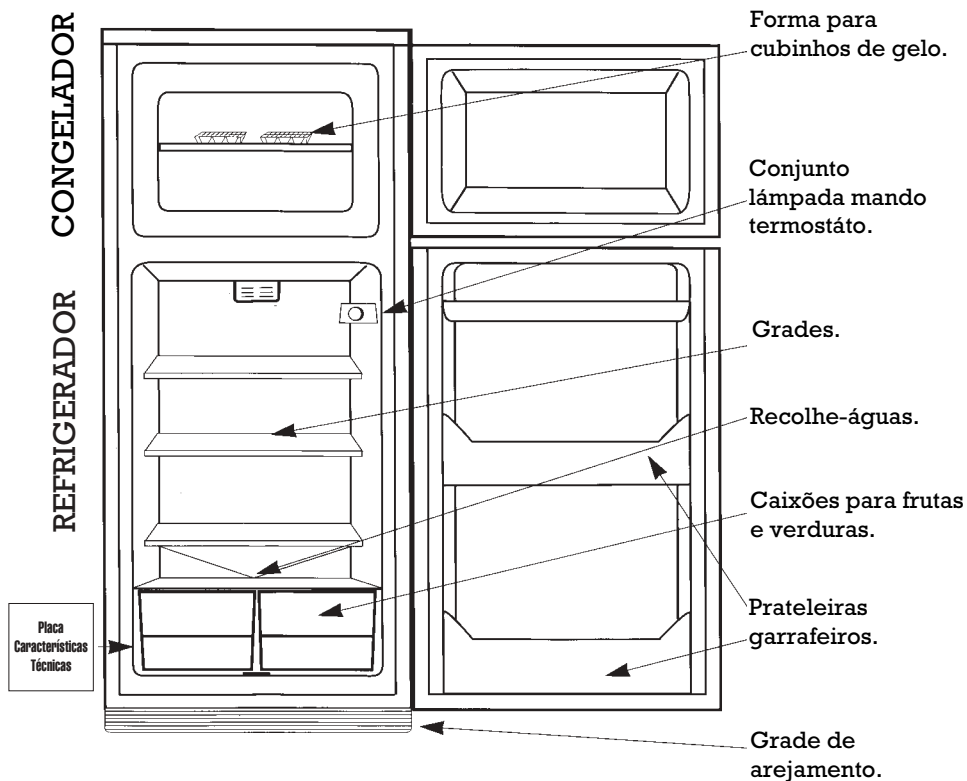

POSTA EM FUNCIONAMENTO

- 1** Accione o mando termostato seleccionando uma posição média.

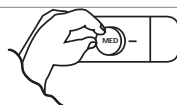

- 2** Feche as portas.

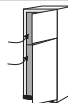

- 3** Passadas 3 horas, já pode introduzir os alimentos no refrigerador. Para congelar alimentos frescos, espere 24 horas.

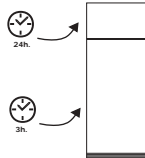

UTILIZAÇÃO DO REFRIGERADOR

ALIMENTOS

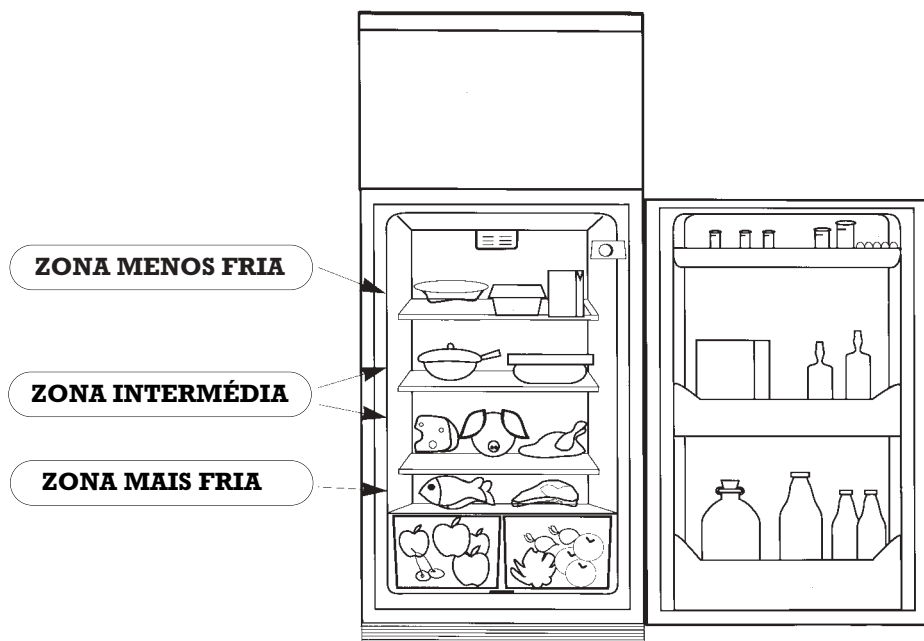

ATENÇÃO

- Girando o mando termostáto pode-se seleccionar mais ou menos frio no refrigerador.
- Deverá ter em conta que a temperatura não é totalmente uniforme em todo o recinto, pelo que existem zonas adequadas para cada tipo de alimento (segundo figura).
- A temperatura no refrigerador pode ver-se afectada pela temperatura ambiente, a localização do aparelho e a frequência com que se abre a porta. Quando a temperatura ambiente é muito alta, obtém-se o melhor rendimento com o termostato na posição média.
- Não introduzir no refrigerador alimentos quentes ou líquidos sem tampar.
- Não introduzir NUNCA líquidos voláteis, inflamáveis ou explosivos, como dissolventes, álcoois, acetona ou gasolina. Existe risco de explosão.
- As carnes e peixes é conveniente embrulhá-los para evitar cheiros.

UTILIZAÇÃO DO REFRIGERADOR

DESGELO

O sistema de degelo do refrigerador funciona automaticamente, por tanto não necessita nenhuma intervenção do usuário.

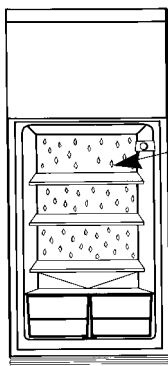

A parede do fundo do refrigerador estará habitualmente cheia de gotinhas de água ou gelo. Isto é totalmente NORMAL e forma parte do processo automático do degelo.

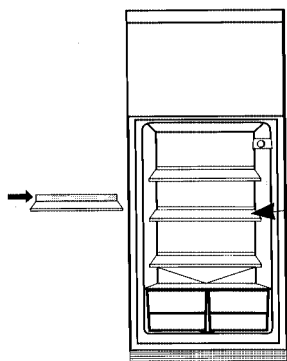

Procure que os alimentos não se encostem a parede do fundo. Para isto as grades dispõem de um tope que não devem ser ultrapassado.

UTILIZACION DEL CONGELADOR

CONGELACION ALIMENTOS FRESCOS

NOTA

El congelador de este frigorífico tiene categoría de 4 * *** estrellas y es capaz de congelar hasta 4 kg. de alimentos frescos en 24 horas.

CONSEJOS

- Envuelva los productos a congelar en papel aluminio o recipientes herméticos.
- Prepare los alimentos en raciones consumibles de una sola vez.
- Nunca congele por segunda vez un alimento descongelado.
- Coloque una etiqueta en el envoltorio indicando el contenido y la fecha de congelación.
- No ponga en contacto directo los alimentos a congelar con los ya congelados.
- No almacene en el congelador bebidas gaseosas.
- Los helados no deben consumirse demasiado fríos.

UTILIZAÇÃO DO CONGELADOR

CONSERVAÇÃO DE ALIMENTOS CONGELADOS

CONSELHOS

- Quando adquira alimentos congelados no comércio, procure que transcorra o menor tempo possível até à sua introdução no congelador.
- Preste atenção ao tempo de conservação marcado nas embalagens dos produtos congelados, tendo em conta que este congelador é de categoria *** ****.
- Para os alimentos congelados por si, consulte a tabela de tempos de conservação.

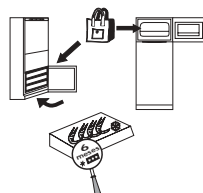

TEMPO DE CONSERVAÇÃO

TIPO DE ALIMENTO

Número Meses

PEIXE E MARISCO	
Lagosta/crustáceos	3
Gambas-Lagostins	3
Pescada	2
Peixe gordo	3/4
Truta	2/3
Salmão	2/3
Linguado	3
Rodvalho	2/3
CARNE	
Vacuna	10/12
Borrego	6/8
Vitela	9
Porco	6
Febras/costoletas	4
Fígado/rim	10
Língua	2
Carne picada, salsichas	2
Coelho	5/7
AVES E CAÇA	
Galinha/fango	10
Perú (aos pedaços)	7
Pato/ ganso	5
Lebre	6
Perdiz-Codorniz	8
Faisão	7/8
Caça grossa	10
PRATOS PREPARADOS	
Molho de tomate	3
Caldo de Carne	3
Asados: vitela, frango, porco	2/3
Sopas de legumes	3
Carne cozida, Estofada	3
Hamburguers	2
Pimentos recheados	2
Espinafres	2
Feijão verde	2
Tartes	5/6
Macedonias de fruta	3
Sandes	6

TIPO DE ALIMENTO

Número Meses

LEGUMES	
Selgas	12
Alcachofas	12
Cenouras	12
Couveflor	6/8
Couves de Bruxelas	6
Espargos	12
Couve	6/8
Feijão	12
Cogumelos	6
Salsa	12
Pimentos	12
Espinafres	12
Fabas	12
FRUTA	
Alperches	8
Cerejas, ameixas, framboesas, groselhas, e amoras	10
Poseegos	10/12
Morangos	12
Compotas (maça, pera)	10
Uva	10/12
Sumos fruta	10
Ananás	10/12
PÃO E PASTELARIA	
Biscoitos-Tartes	6
Massa folhada	1
Masa pasteleira	3
Pão e bolos	2
OVOS, LEITE E DERIVADOS	
Ovos (sem casca)	6
Leite homogeneizada (embalagem de cartão)	3
Manteiga	6
Queijo (pequenas doses)	6/8
Natas fresca	3

UTILIZAÇÃO DO CONGELADOR

DESCONGELAÇÃO DOS ALIMENTOS

Nem todos os alimentos devem ser descongelados da mesma maneira.

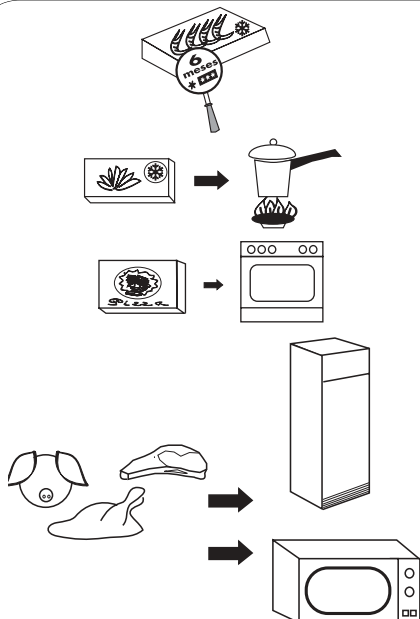

Se Você adquiriu o alimento congelado no comércio, siga as instruções do vasilhame.

As verduras devem cozinhar-se directamente.

Geralmente, os alimentos preparados ou pré-cozinhados podem cozinhar-se directamente.

Carnes e peixes ter-se-ão de descongelar lentamente no refrigerador durante várias horas. Se Você dispõe de forno microondas, poderá acelerar a descongelação mais rapidamente.

PRODUÇÃO DOS CUBINHOS DE GELO

1

Encha até as três quartas partes de água as formas que encontrará no interior do congelador.



2

Introduza as formas no congelador, preferivelmente na parte inferior.

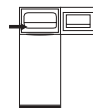

3

Uma vez congelada a água, pode desenformar os cubinhos retorcendo levemente as formas.

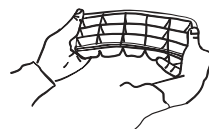

UTILIZAÇÃO DO CONGELADOR

DESGELO E LIMPEZA

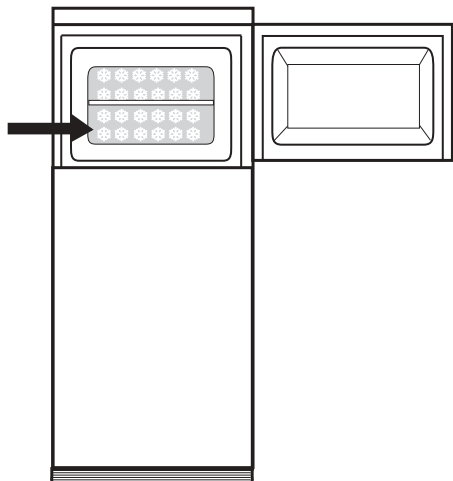

Com o tempo, nas paredes do congelador se vai formando uma capa de escarcha ou gelo. Isto provocará um maior consumo de energia no vosso frigorífico. Para evitá-lo, terá que eliminar esta capa de gelo, ao menos 2 vezes ao ano.

- 1 Coloque o mando termostático na posição de STOP e o frigorífico ficará desligado.

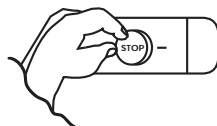

- 2 Pode ajudar a eliminar o gelo com a ajuda dum pázinha ou metendo um recipiente com água quente. Não utilize objectos afiados nem aparelhos de aquecimento eléctricos.

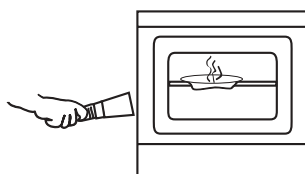

- 3 Recolha a água do degelo com um pano absorvente, limpe e seque bem o interior.

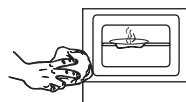

- 4 Accione o mando termostático à posição habitual de funcionamento.

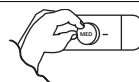

- 5 2 horas mais tarde, já pode voltar a introduzir os alimentos congelados no congelador.

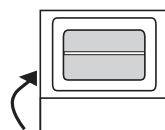

LIMPEZA E MANUTENÇÃO

LIMPEZA

CONSELHOS

Para a limpeza do interior o frigorífico deve estar desligado.

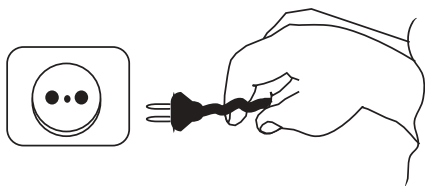

Não utilize produtos abrasivos, dissolventes, limpadores de metais ou detergentes não diluídos.



É conveniente limpar uma vez ao ano com um aspirador a grade da parte posterior do frigorífico. A sujeira prejudica o funcionamento e aumenta o consumo de energia eléctrica.

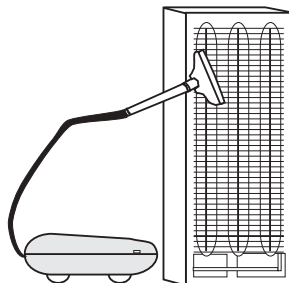

PARADA TEMPORAL DO FRIGORIFICO

- Desligue o frigorífico.
- Retire os alimentos, limpe e seque o interior.
- Deixe a porta aberta para evitar a formação de mau cheiro.
- Faça o mesmo no caso de corte de corrente eléctrica prolongado ou falha do frigorífico.

TROCA DA LÂMPADA

1- Desligar o frigorífico.

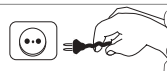

2- Retirar a lâmpada estragada e repô-la com outra do mesmo tipo.



 220 v
15 w max.
E 14

MUDANÇA DE SENTIDO DE ABERTURA DAS PORTAS

- 1 Tombe o frigorífico sobre a parte traseira.

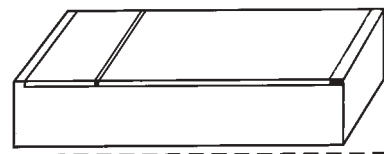

- 2 Se o seu frigorífico leva base inferior, extraia-la tal e como se indica na figura. Em seguida, rasgue a parte esquerda marcada no rodapé para alojar a dobradiça inferior segundo a

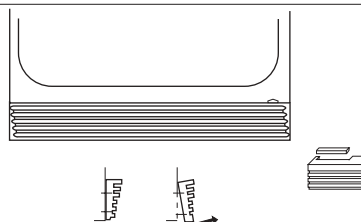

- 3 Tire para fora a bisagra inferior soltando os tres parafusos de sujeção (A). Solte o eixo (B) da posição direita e monte-o na posição esquerda da bisagra. Solte os dois parafusos (C) e aparafuse-os no lado direito. Retire a porta inferior.

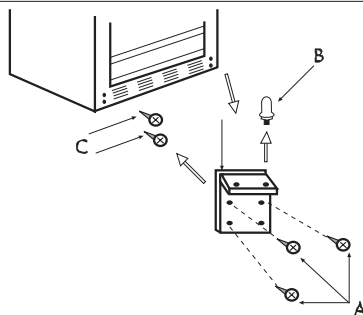

- 4 Tire para fora a bisagra intermedia retirando a chapinha protetora que esconde os parafusos e soltando-os. Tire tambem a tampinha do lado esquerdo e coloque-a donde estava a bisagra. Retire a porta superior.

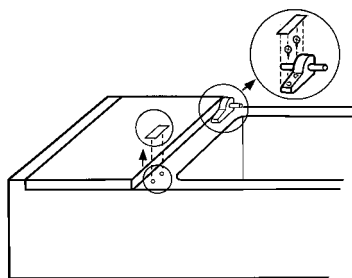

- 5 Tire para fora o eixo (D) da posição direita e monte-os na posição esquerda.

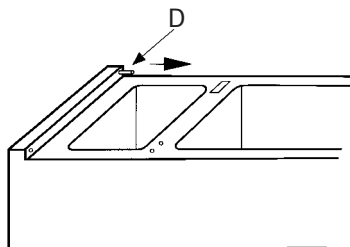

- 6** Retire o tampão do eixo esquerdo da porta inferior e ponhá-o no eixo direito (os modelos paineláveis não levam este tampão).

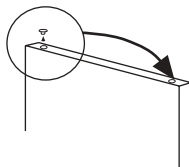

- 7** Coloque a porta superior introduzindo-a no eixo situado no lado esquerdo.

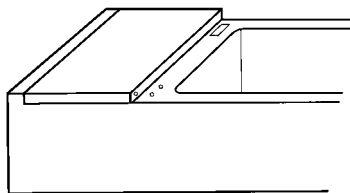

- 8** Meta a bisagra intermedia na lado esquerdo da porta superior e aparafuse-a ao frigorífico. Coloque a porta superior introduzindo-a no eixo da bisagra intermedia. A seguir coloque a tampinha protetora que esconde os parafusos de sujeção.

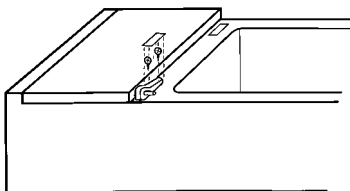

- 9** Meta a bisagra inferior no lado esquerdo e aperte-a com os tres parafusos.

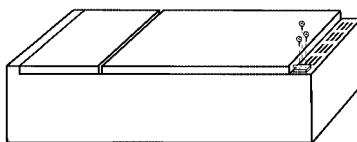

- 10** Volte a colocar o rodapé inferior na sua posição.

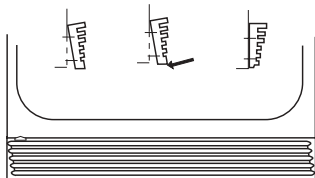

- 11** Se o vosso frigorífico é revestível deverá mudar de lado os puchadores das portas.

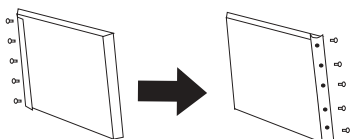

REVESTIMENTO DE PAINÉIS

Se o vosso frigorífico é um modelo revestível e deseja assemelhar o aspecto exterior do vosso frigorífico com o resto do mobiliário da vossa cozinha, pode revestir as portas com painéis seguindo estas instruções.

1

Dimensões do móvel frigorífico e dos painéis das portas.

(Espesor dos painéis menor de 4 mm)

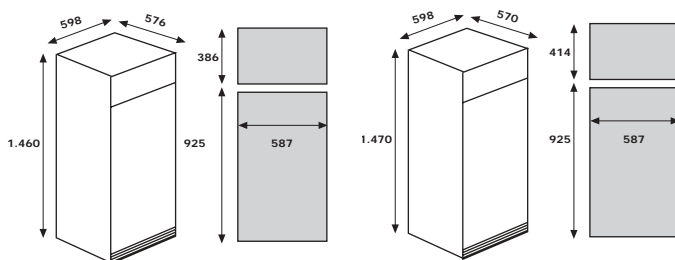

2

Extrair o puchador e/ou o marco do lado esquerdo da porta soltando os correspondentes parafusos.

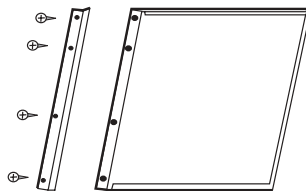

3

Afrouxe o resto dos parafusos do contorno da porta retirando os marcos como indica a figura, e introduza o painel, deslizando-o.

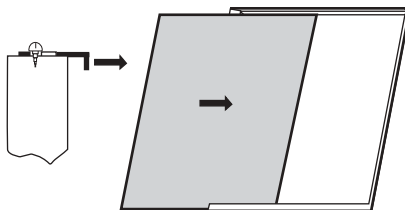

4

Aperte a beirada do marco contra o painel e sujeite os parafusos do marco nessa posição. Coloque o marco e/ou o puchador com os seus parafusos.

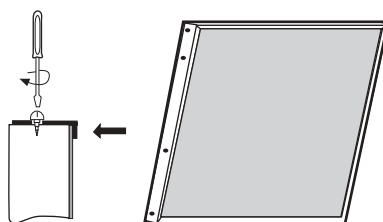

PROBLEMAS DE FUNCIONAMIENTO

PROBLEMA	CAUSA POSIBLE	SOLUCION
El frigorífico no funciona	El enchufe no está conectado a la toma de corriente.	Conectar enchufe.
	No llega corriente eléctrica al enchufe por haberse fundido el fusible o por haber saltado el limitador automático de potencia.	Cambiar fusible o volver a conectar el limitador automático de potencia.
El refrigerador enfría poco	El mando termostato se encuentra en una posición baja.	Gire el mando termostato a una posición de más frío.
	Se ha dejado la puerta mal cerrada o se ha abierto con mucha frecuencia.	Cuidar que la puerta no permanezca abierta mucho tiempo.
	Se ha obstaculizado la rejilla de aireación o la abertura de la parte posterior del techo.	Conservar libres estas zonas según se indica en el capítulo "Instalación" de este manual.
Gotas de agua en la pared del fondo del refrigerador	El frigorífico está expuesto directamente a los rayos de sol o a una fuente de calor.	Cambiar la ubicación del frigorífico o protegerlo de esas fuentes de calor.
	Ciclo automático de deshielo.	No se alarme: esto es completamente normal (ver capítulo "Utilización del refrigerador" de este manual).
Aparece agua en la base del refrigerador	Se ha colocado algún alimento o recipiente pegado a la pared del fondo del refrigerador.	No ponga alimentos o recipientes en contacto con la pared del fondo y evitará el derrame del agua de deshielo.
Mucho hielo en las paredes y estantes del congelador	La puerta congelador no cierra bien por estar obstaculizada.	Procure un buen cierre de las puertas manteniéndolas libres de objetos o suciedad.
La lámpara del refrigerador no enciende	El enchufe no está conectado a la toma de corriente.	Conectar enchufe.
	No llega corriente eléctrica al enchufe por haberse fundido el fusible o por haber saltado el limitador automático de potencia.	Cambiar fusible o volver a conectar el limitador automático de potencia.
	La lámpara está floja.	Enroscar correctamente.
Funcionamiento ruidoso	La lámpara está fundida.	Cambiar la lámpara según se indica en este manual.
	El frigorífico no ha sido nivelado correctamente.	Nivelar según se indica en el capítulo "Instalación" de este manual.
Ruido de borboteo	Ciclo funcionamiento.	No se alarme, esto es completamente normal.
Los alimentos se secan	Los alimentos no están envueltos o tapados.	Envolverlos o introducirlos en recipientes herméticos.
Olores en el interior	Algún alimento no está correctamente envuelto o tapado.	Envolverlo o introducirlo en un recipiente hermético.
	El interior del aparato necesita una limpieza.	Limpiar según se indica en este manual.

SERVICIO DE ASISTENCIA TÉCNICA

Si Vd. ya ha realizado las comprobaciones indicadas y su problema persiste, **NO EFECTUE NINGUNA OTRA REPARACION VD. MISMO**. Pongase en contacto con el Servicio de Asistencia Técnica más próximo.

ESPECIFICAÇÕES

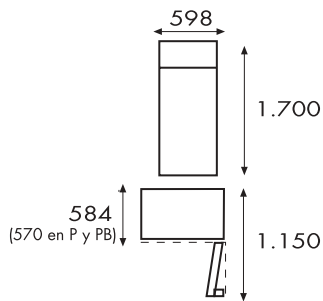
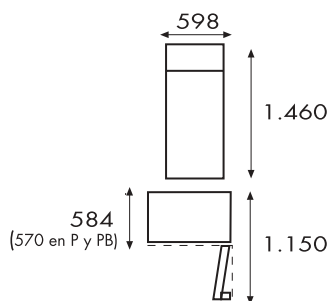

ESTES APARELHOS CUMPREM AS
DIRECTIVAS DA CEE: 73/23, 93/68, 89/336

INDEX

	Page
Installation	2
Description générale	3
Utilisation du réfrigérateur	4
Utilisation du congélateur	6
Nettoyage et entretien	10
Changement du sens d'ouverture des portes	11
Problèmes de fonctionnement	13
Schéma électrique.....	14
Spécifications	14

AVIS

Si votre ancien réfrigérateur dispose de pènes à fermeture automatique ou manuelle, **N'OUBLIEZ PAS DE DETRUIRE OU D'INUTILISER LE SYSTEME DE FERMETURE** avant de l'envoyer a la ferraille. Ceci évitera que, dans leurs jeux, des enfants puissent demeurer enfermés à l'intérieur. **N'ENDOMMAGEZ PAS LES TUYAUTERIES** et vous éviterez ainsi que le réfrigérant puisse s'échapper sans contrôle dans l' atmosphère.

INSTALLATION

RECOMMANDATIONS

Permettre la circulation de l'air sur la partie postérieure du réfrigérateur. Ne permettre à aucun objet de boucher la grillage avant ou le façade du réfrigérateur. Si l'on installe une armoire au-dessus, il faudra laisser un creux pour permettre la circulation de l'air.

Eviter dans toute la mesure du possible la proximité des sources de chaleur.

Si vous avez besoin de coucher le réfrigérateur pour le déballer ou pour changer de côté ses gonds de pivotement de ses portes, **LE REFRIGERATEUR NE PEUT ETRE COUCHE QUE SUR SA PARTIE POSTERIEURE.**

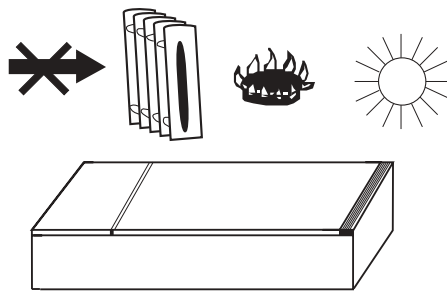

NOTE: Les charnières des portes se trouvent sur le côté droit. Si cette disposition s'avère gênante pour vous, il est possible de changer la place des charnières. Les instructions se trouvent dans l'annexe CHANGEMENT DU SENS D'OUVERTURE DES PORTIERES.

IMPORTANT: En réglant les pieds de nivellement, s'assurer que le réfrigérateur est bien appuyé sur le sol (sans boitement) et est bien nivelé (pas incliné).

Ce réfrigérateur fonctionne à 220/230v. Si vous disposez d'une tension différente dans votre foyer, vous devrez utiliser un transformateur d'une puissance non inférieure à 700 w. Utilisez une prise de courant avec MISE A TERRE.

NOTE: Le fabricant décline toute responsabilité au cas où ses instructions ne seraient pas suivies.

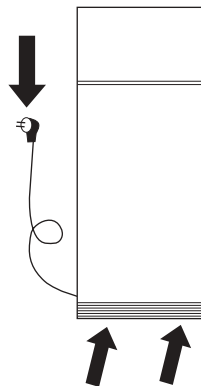

ATTENTION AVANT DE CONNECTER

1.- Nettoyer l'intérieur du réfrigérateur.



2.- Pour un fonctionnement correct, attendre deux heures avant de le brancher.



3.- Connecter.



DESCRIPTION GENERALE

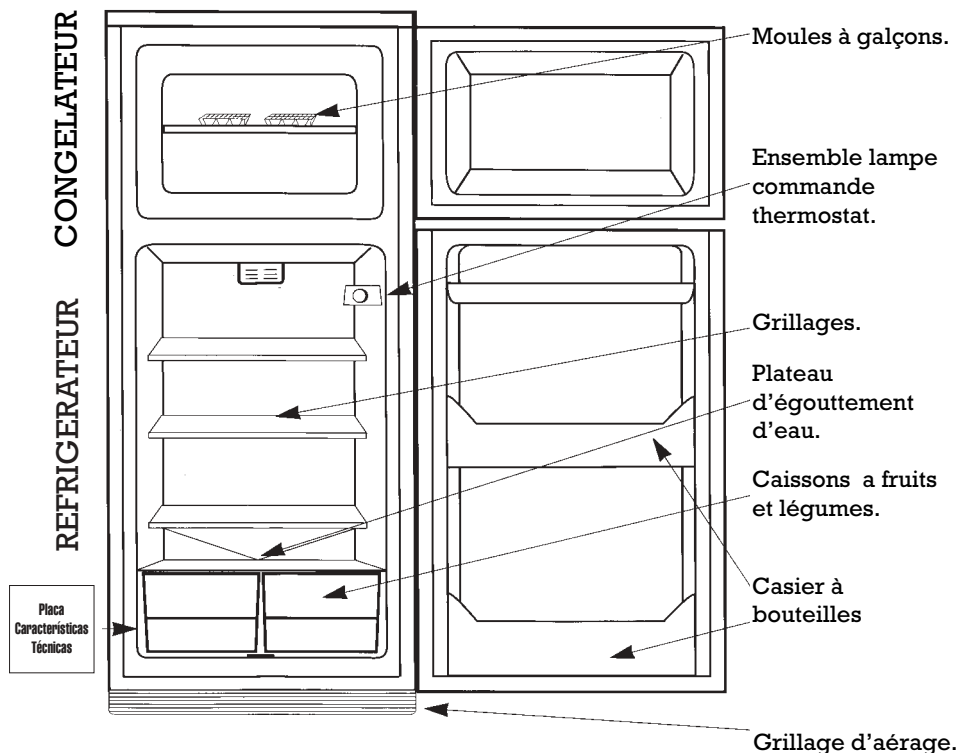

FRANCAIS

MISE EN FONCTIONNEMENT

1

Actionner la commande de thermostat en sélectionnant la position intermédiaire.

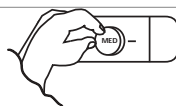

2

Fermer les portes.

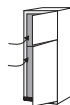

3

Au bout de 3 heures, on peut introduire des aliments dans le réfrigérateur.
Pour congeler des aliments frais, attendre 24 heures.

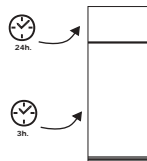

UTILISATION DU REFRIGERATEUR

ALIMENTS

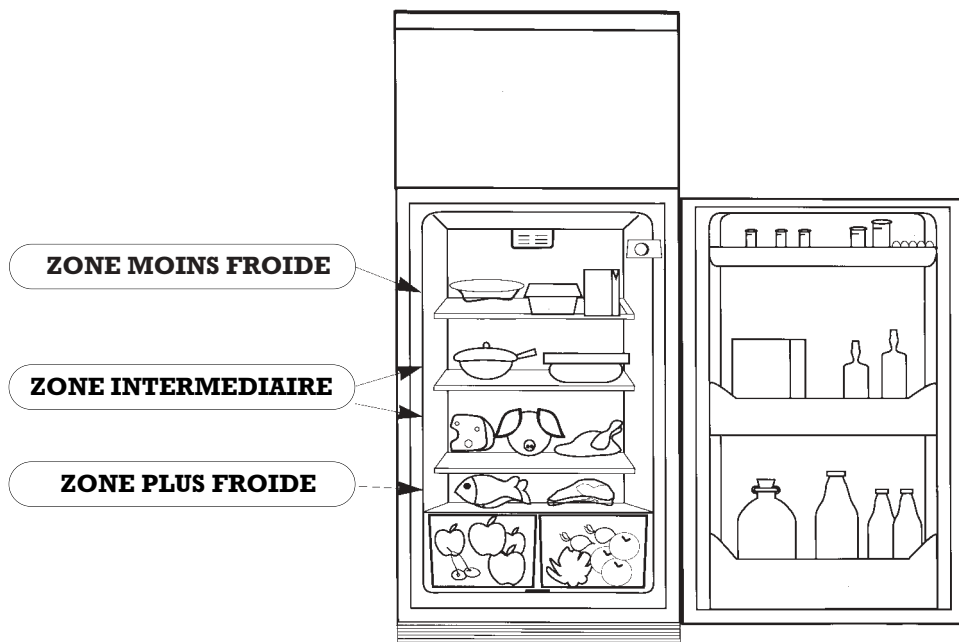

ATTENTION

- En tournant la commande du thermostat, on peut sélectionner plus ou moins de froid dans le réfrigérateur.
- Il y a lieu de prendre en considération que la température n'est pas totalement uniforme dans toute l'enceinte, raison pour laquelle il y a des zones appropriées pour chaque type d'aliment (suivant la figure).
- La température dans le réfrigérateur peut être affectée par la température ambiante, l'emplacement de l'appareil et la fréquence d'ouverture de la porte. Lorsque la température ambiante est très élevée, le thermostat doit être à une position intermédiaire pour obtenir le meilleur rendement.
- Ne pas introduire dans le réfrigérateur des aliments chauds ou des liquides non bouchés.
- Ne JAMAIS introduire des liquides volatiles, inflammables ou explosifs, tels que des dissolvants, des alcools, de l'acétone ou de l'essence. Il y aurait un risque d'explosion.
- Il convient d'envelopper les viandes et les poissons pour éviter des odeurs.

UTILISATION DU REFRIGERATEUR

DEGEL

Le système de dégel du réfrigérateur fonctionne de façon automatique et n'exige donc aucune intervention de l'utilisateur.

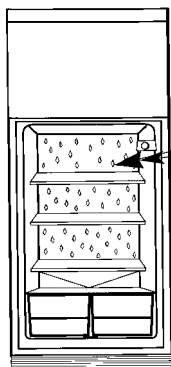

La paroi du fondo du réfrigérateur sera habituellement couverte de gouttelettes d'eau ou de glace. Ceci est tout à fait NORMAL et fait partie du processus de dégel automatique.

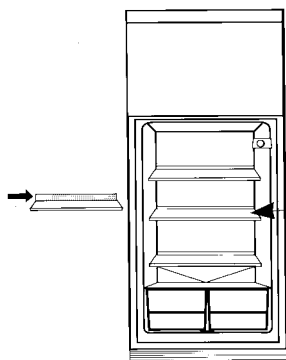

Veiller à ce que les aliments ne touchent pas la paroi du fond. A cette fin, les grillages sont pourvus d'une butée qu'il y a lieu de ne pas dépasser.

UTILISATION DU CONGELATEUR

CONGELATION D'ALIMENTS FRAIS

NOTE

Le congélateur de ce réfrigérateur a une catégorie de *** ***** 4 étoiles dans n'importe lequel de ses tiroirs et est capable de congeler jusqu'à 4kg d'aliments frais en 24 heures.

CONSEILS

- Envelopper les produits à congeler dans du papier aluminium ou les disposer dans des récipients hermétiques.
- Préparer les aliments en rations consommables en une seule fois.
- Ne jamais congeler une deuxième fois un aliment décongelé.
- Coller une étiquette sur l'emballage pour en indiquer le contenu et la date de congélation.
- Ne pas mettre en contact direct les aliments à congeler et ceux qui le sont déjà.
- Ne pas stocker dans le congélateur des boissons gazeuses.
- Les glaces ne doivent pas être consommées trop froides.

UTILISATION DU CONGELATEUR

CONSERVATION DES ALIMENTS CONGELES

CONSEILS

- Lorsque vous achetez des aliments congelés ou surgelés dans le commerce, veillez à les laisser le minimum de temps possible en dehors du congélateur.
- Respectez la durée de conservation indiquée sur les emballages des produits congelés et surgelés, en tenant compte que votre congélateur est de ********.
- Pour les aliments que vous congelez vous-mêmes, consultez le tableau des temps de conservation ci-dessous.

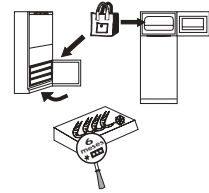

TIEMPS DE CONSERVATION

TYPE D'ALIMENT	Nombre de mois
POISSON ET FRUIT DE MER	
Langouste-crustacés	3
Bouquets-cros bouquets	3
Colin	2
Poissons grass	3/4
Truite	2/3
Saumon	2/3
Soie	3
Turbot	2/3
VIANDE	
Gros bovin	10/12
Agneau	6/8
Porc	9
Filets et côtelettes	6
Foie/Rognons	4
Higado/Riñones	10
Cervelle/Langue	2
Viande hachée/saucisses	2
Lapin	5/7
VALOILLES ET GIBIER	
Poules-poulets	10
Dindon (découpé)	7
Canard, jars, oie	5
Lièvre	6
Perdrix-Caille	8
Faisan	7/8
Gros gibier	10
PLATS CUISINES	
Sauces de tomate	3
Consommé	3
Rôtis: boeuf, veau, poulet, porc	2/3
Jardinière de légumes	3
Viande cuite ou à l'étouffée	3
Bifteq haché (hamburger)	2
Poivrons farcis	2
Epinards	2
Haricots verts et sautés	2
Gâteau, friands, etc	5/6
Macédoine de fruits	3
Sandwichs	6

TYPE D'ALIMENT	Nombre de mois
LEGUMES	
Bettes	12
Artichauts	12
Carottes	12
Chou-fleur	6/8
Choux de Bruxelles	6
Asperges	12
Choux	6/8
Haricots	12
Champignons	6
Persil	12
Poivrons	12
Epinards	12
Fèves	12
FRUITS	
Abricots	8
Cerises, prunes, framboises, groseilles, mûres	10
Pêches	10/12
Fraises	12
Compotes (pommes, poires)	10
Raisins	10/12
Jus de fruits	10
Ananas	10/12
PAIN ET PASTELERIE	
Biscuits, gâteaux	6
Gâteaux feuilleté	1
Pâte à pâtisserie	3
Pain et brioches	2
OEUFs, LAIT ET DERIVES	
Oeufs (san coque)	6
Lait homogénéisé (emballage carton)	3
Beurre	6
Fromages (petites portions)	6/8
Crème fraîche	3

UTILISATION DU CONGELATEUR

DECONGELATION D'ALIMENTS

Tous les aliments ne doivent pas être décongelés de la même façon.

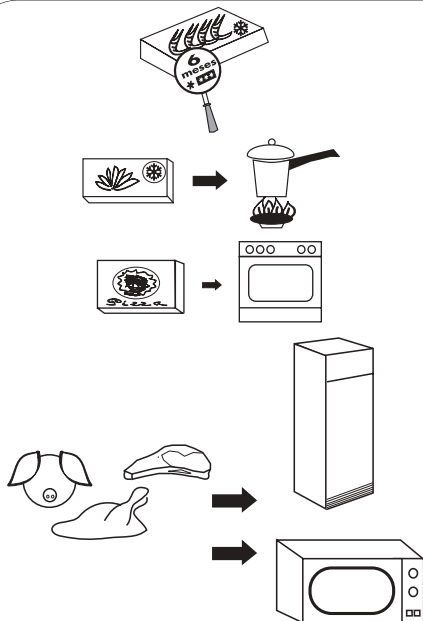

Si vous avez acheté l'aliment congelé dans le commerce, suivez les instructions indiquée sur l'emballage.

Les légumes doivent être cuisinés directement.

En général, les aliments préparés ou précuits peuvent être cuisinés directement.

Les viandes et les poissons doivent être décongelés lentement dans le réfrigérateur pendant plusieurs heures. Si vous disposez d'un four à micro-ondes, vous pourrez accélérer la décongélation dans une grande mesure.

PRODUCTION DES GLAÇONS

1

Remplir d'eau aux trois quarts les moules qui se trouvent à l'intérieur du congélateur.



2

Introduire les moules dans le congélateur, préférablement dans la partie inférieure.

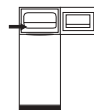

3

Une fois l'eau congelée, on peut extraire les glaçons de leur moule en tordant légèrement ce dernier.

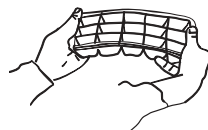

UTILISATION DU CONGÉLATEUR

DEGEL ET NETTOYAGE

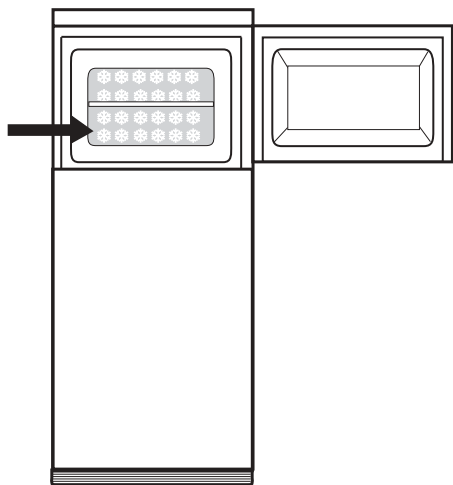

Avec le temps, il se forme sur les parois du congélateur une couche de givre ou de glace. Ceci entraînera une consommation plus grande d'énergie dans votre réfrigérateur. Afin de l'éviter, il y a lieu d'éliminer cette couche de glace au moins deux fois par an.

FRANÇAIS

1

Placer la commande de thermostat sur la position de STOP et le congélateur sera déconnecté.

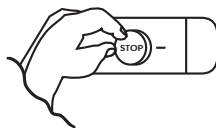

2

On peut aider à éliminer la glace à l'aide de la palette ou en introduisant un récipient d'eau chaude. Ne pas utiliser des objets tranchants ni des appareils de chauffe électriques.

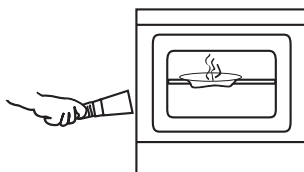

3

Recueillir à l'eau de dégel à l'aide d'un torchon absorbant; nettoyer et sécher l'intérieur avec soin.

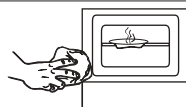

4

Actionner la commande de thermostat et la placer dans sa position habituelle de fonctionnement.

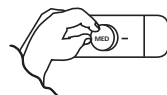

5

Deux heures plus tard, on peut introduire à nouveau les aliments congelés dans le congélateur.

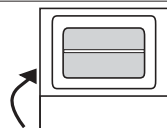

NETTOYAGE ET ENTRETIEN

NETTOYAGE

CONSEILS

Pour nettoyer l'intérieur, le réfrigérateur doit être débranché.

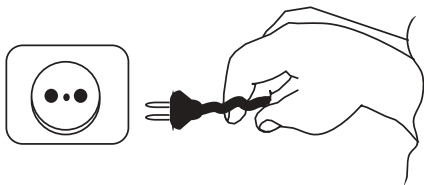

Ne pas utiliser de produits abrasifs, dissolvants, de nettoyage des métaux ou des détergents non dilués.



Il convient de nettoyer une fois par an avec un aspirateur le grillage arrière du réfrigérateur. La saleté a un effet préjudicial sur le fonctionnement et augmente la consommation en énergie électrique.

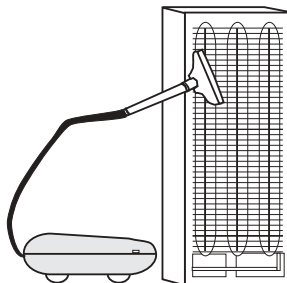

ARRET PROVISOIRE DU REFRIGERATEUR

- Débrancher le réfrigérateur.
- Retirer les aliments, nettoyer et sécher l'intérieur.
- Laisser la porte ouverte afin d'éviter qu'il ne se forme de mauvaises odeurs.
- Agir de la même façon en cas de coupure prolongée de courant ou de panne du réfrigérateur.

REMPACEMENT DES AMPOULES

1- Déconnecter le réfrigérateur.

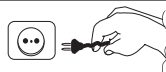

2- Enlever l'ampoule grillée et la remplacer par une autre du même type.

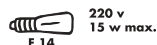

CHANGEMENT DU SENS D'OUVERTURE DES PORTES

- 1 Couchez le réfrigérateur sur sa partie arrière.



- 2 Si le bas de votre réfrigérateur est équipé d'une plinthe, enlevez celle-ci comme il est indiqué sur la figure. Pour suivre, déchirer la partie gauche marquée du socle pour loger la charnière inférieure suivant la figure.

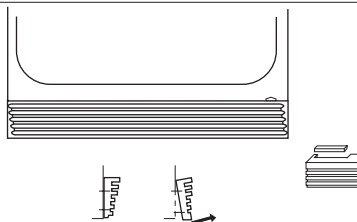

- 3 Retirez la charnière inférieure en défaisant les 3 vis de fixation (A). Retirez le pivot (B) de la position droite et placez-le en position gauche de la charnière. Retirez les 2 vis (C) et vissez-les du côté droit. Déposez la porte inférieure.

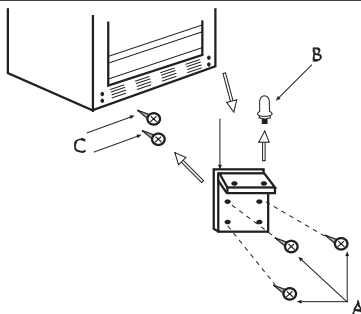

- 4 Retirez la charnière intermédiaire après avoir enlevé la plaquette de protection cachant les vis et enlevez ces dernières. Retirez également la plaquette de gauche et placez-la où était la charnière. Déposez la porte supérieure.

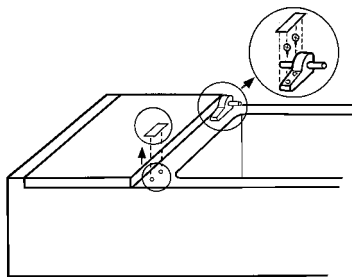

- 5 Retirez le pivot (D) de la position droite et placez-le en position gauche.

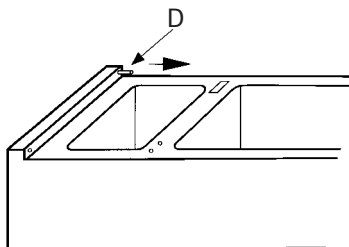

- 6** Enlever le bouchon du tube axial gauche des portes et le placer dans le tube axial droit (les modèles habillables ne sont pas pourvus de ce bouchon).

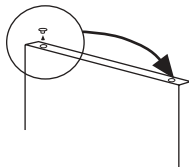

- 7** Pour remettre en place la porte supérieure, positionnez-la sur le pivot placé du côté gauche.

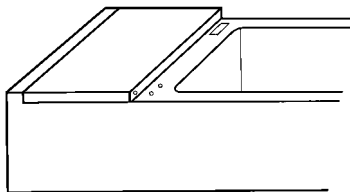

- 8** Introduisez la charnière intermédiaire sur le pivot gauche de la porte supérieure et vissez-la au réfrigérateur. Mettez en place la porte inférieure en la positionnant sur le pivot de la charnière intermédiaire, puis remettez en place la plaquette de protection des vis de fixation.

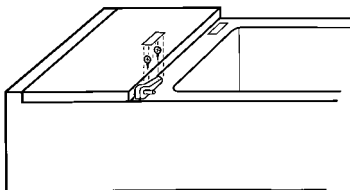

- 9** Introduisez la charnière inférieure dans le logement situé à gauche et fixez-la avec les trois vis.

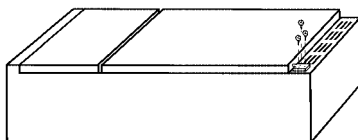

- 10** Replacer le socle inférieur en sa position.

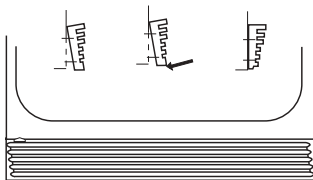

- 11** Si votre réfrigérateur admet le lambrissage à panneaux, il faudra changer de côté les poignées des portes.

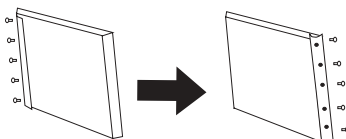

PROBLEMES DE FONCTIONNEMENT

PROBLEME	CAUSE POSSIBLE	SOLUTION
Le réfrigérateur ne fonctionne pas.	La fiche n'est pas connectée à la prise de courant. Le courant électrique n'arrive pas à la fiche car le fusible est fondu ou le limiteur automatique de puissance a sauté.	Connecter la fiche. Changer le fusible ou reconnecter le limiteur automatique de puissance.
Le réfrigérateur refroidit peu.	La commande de thermostat se trouve en une position basse.	Tourner la commande du thermostat sur une position plus froide.
	On a laissé la porte mal fermée ou on l'a ouverte avec une fréquence excessive.	Veiller à ce que la porte ne reste pas longtemps ouverte.
	On a abstrué le grillage d'aéragé ou l'ouverture de la partie arrière du faite du réfrigérateur. Le réfrigérateur est directement exposé aux rayons du soleil ou à une source de chaleur.	Conservé ces zones libres comme il est indiqué au chapitre "Installation" de ce manuel. Changer l'emplacement du réfrigérateur ou le protéger contre ces sources de chaleur.
Il y a des gouttes d'eau sur la paroi du fond du réfrigérateur.	Cycle automatique de dégel.	Ne pas s'alarmer: c'est tout à fait normal (voir le chapitre "Utilisation du réfrigérateur" de ce manuel).
Il apparait de l'eau sur en bas du réfrigérateur.	On a placé un aliment ou un récipient contre la paroi du fond du réfrigérateur.	Ne pas placer d'aliments ou de récipients en contact avec la paroi du fond; ceci évitera l'écoulement de l'eau de dégel.
Trop de glace sur les parois et étagères du réfrigérateur.	La porte du congélateur ferme mal à cause d'un obstacle.	Veiller à la bonne fermeture des portes et les maintenir libres d'objets ou de saleté.
La lampe du réfrigérateur ne s'allume pas.	La fiche n'est pas connectée à la prise de courant.	Connecter la fiche.
	Le courant électrique n'arrive pas à la prise parce que le fusible est fondu ou parce que le limiteur automatique de puissance a sauté.	Changer le fusible ou reconnecter le limiteur automatique de puissance.
	La lampe n'est pas vissée à fond.	La visser correctement.
	La lampe est grillée.	Changer l'ampoule comme il est indiqué dans ce manuel.
Fonctionnement bruyant.	Le réfrigérateur n'a pas été nivelé correctement.	Niveler comme il est indiqué au chapitre "Installation" de ce manuel.
Bruit de barbotage	Cycle de fonctionnement.	Ne pas s'alarmer: ceci est tout à fait normal.
Les aliments se dessèchent.	Les aliments ne sont pas enveloppés ou recouverts.	Les envelopper ou l'introduire dans un récipient hermétique.
Il y a des odeurs à l'intérieur.	Un des aliments n'est pas enveloppé ou recouvert.	L'envelopper ou l'introduire dans un récipient hermétique.
	L'intérieur de l'appareil a besoin d'être nettoyé.	Nettoyer comme il est indiqué dans ce manuel.

SERVICE D'ASSISTANCE TECHNIQUE

Si vous avez déjà réalisé les vérifications indiquées et votre problème persiste, NE REALISEZ AUCUNE AUTRE REPARATION VOUS-MEME. Mettez-vous en rapport avec le Service d'Assistance Technique le plus proche.

SPECIFICATIONS

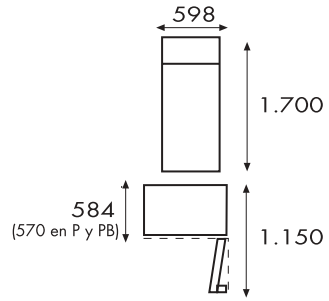
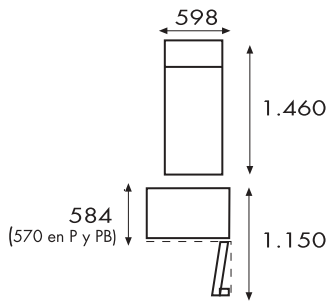

CES APPAREILS RESPECTENT LES
DIRECTIVES CEE: 73/23, 93/68, 89/336

CONTENS

	Page
Installation	2
General Description.....	3
Using the refrigerator	4
Using the freezer.....	6
Cleaning and Maintenance	10
Changing the direction of the doors	11
Problems	13
Electrical diagram	14
Specifications.....	14

WARNING

If your old refrigerator has a manual or automatic door locking device **DO NOT FORGET TO DESTROY OR INCAPACITATE THE LOCKING SYSTEM** before throwing it away, in order to prevent children from locking themselves inside whilst playing.

DO NOT DAMAGE THE PIPES to avoid an uncontrolled leakage of coolant into the atmosphere.

INSTALLATION

RECOMMENDATIONS

Allow air to circulate behind the refrigerator.

Do not cover the front grill or top of the refrigerator with any object. If the refrigerator is placed underneath a cupboard, leave a space for air to circulate.

As far as possible avoid locating near to heat sources.

If the refrigerator needs to be laid down for unpacking or to change the direction of the doors, **ONLY LAY IT DOWN ON THE REAR SECTION.**

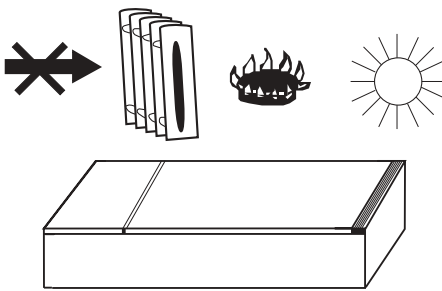

NOTE: The door hinges are on the right. If this is inconvenient the hinges can be changed to the other side. Instructions are contained in the section on changing the direction of door opening.

IMPORTANT. Ensure that the refrigerator is well seated on the ground (without movement) and is properly levelled (without tilting) by adjusting the levelling feet.

This refrigerator operates at 220/230 v. If the voltage in your home is different, a transformer should be used with an output of not less than 700 W.

Use an **EARTHED** plug.

NOTE: The manufacturer will not accept any liability in the event that these recommendations are not followed.

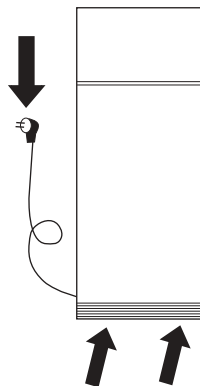

BEFORE CONNECTING TO THE POWER

1.- Clean the inside of the refrigerator.



2.- Wait for 2 hours before connecting, to ensure proper functioning.



3.- Connect to the power.



GENERAL DESCRIPTION

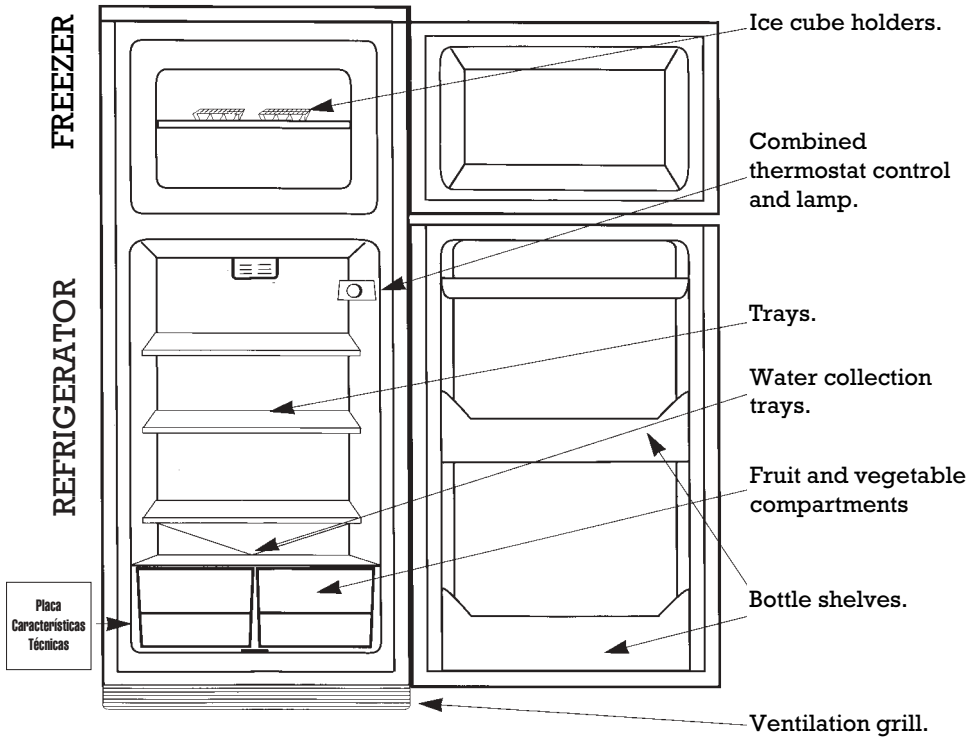

STARTING UP

- 1 Move the thermostat control to an intermediate position.

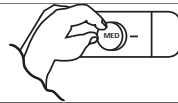

- 2 Close the doors.

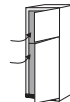

- 3 Food can be placed in the refrigerator three hours later. Wait for 24 hours before freezing fresh food.

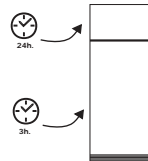

USING THE REFRIGERATOR

FOOD

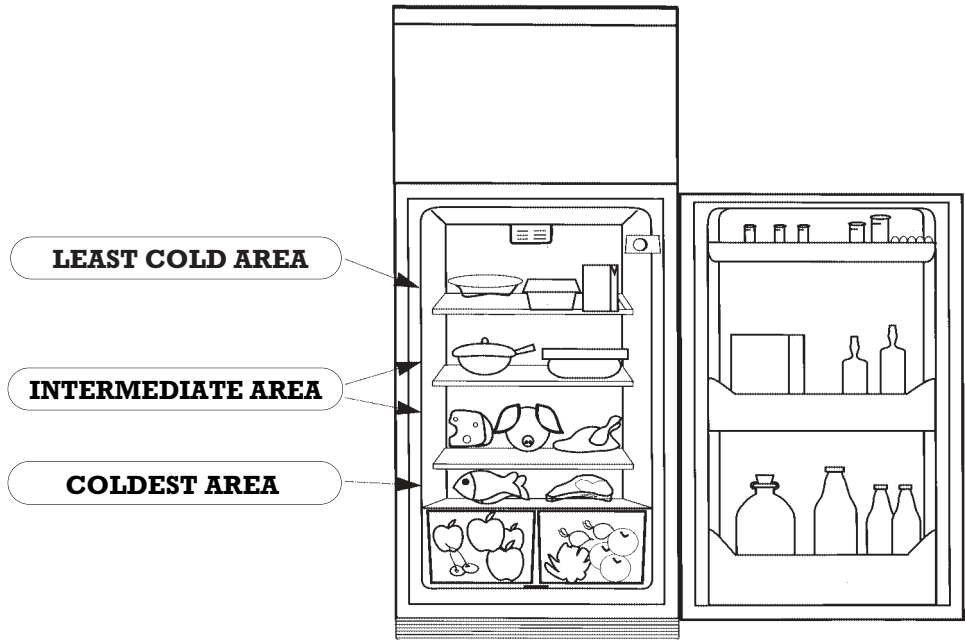

ATTENTION

- The temperature inside the refrigerator can be selected by turning the thermostat control.
- Remember that the temperature is not totally uniform within the interior as a whole and different sections are more suitable for different types of food (as shown in the diagram).
- The temperature inside the refrigerator can be affected by the ambient temperature, the location of the refrigerator and the frequency with which the door is opened. In the event of very high room temperatures, midrange setting of the thermostat will generate the best results.
- Do not place uncovered liquids or hot food in the refrigerator.
- NEVER place volatile, inflammable or explosive liquids in the refrigerator, such as solvents, alcohols, acetone or petrol as there will be a risk of explosion.
- Meat and fish should be wrapped to avoid smells developing.

USING THE REFRIGERATOR

DEFROSTING

The refrigerator has an automatic defrosting system and it is not therefore necessary to take any action.

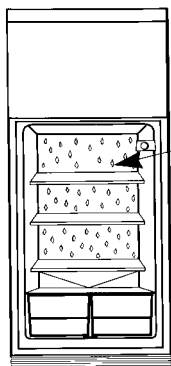

The back wall of the refrigerator is normally covered with drops of water or ice. This is completely **NORMAL** and is part of the automatic defrosting process.

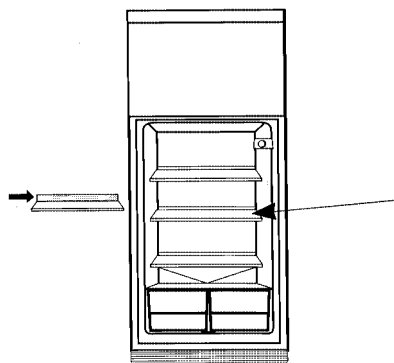

Ensure that foods does not touch the back wall. The trays have a limit point for this purpose which should not be exceeded.

USING THE FREEZER

FREEZING FRESH FOOD

NOTE

All the baskets in the freezer section of this refrigerator are in the ******** 4 star category and up to 4 kg of fresh food can be frozen in 24 hours.

ADVICE

- Wrap products to be frozen in aluminium foil or place them in sealed containers.
- Prepare foods in single consumption portions.
- Never refreeze food which has been defrosted.
- Label food with details of the contents and date frozen.
- Do not place food to be frozen in direct contact with food already frozen.
- Do not place fizzy drinks in the freezer section.
- Ice-cream, etc. should not be consumed at low a temperature.

DIRECTIONS FOR USE YOUR FREEZER

FROZEN FOOD PRESERVATION

A FEW HINTS

- When you buy frozen food in your shop, try to introduce the products into the freezer as soon as possible.
- Observe the preservation time that appear on the product packing, taking into account this * ❄️ freezer.
- When freezing food by yourself, consult the list of preservation times.

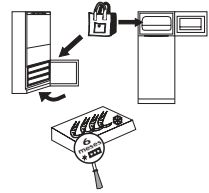

CONSERVATION TIMES

SORT OF FOOD	Number of months
FISH AND SHELLFISH	
Lobsters	3
Shrimps	3
Cold	2
Sardines and similar	3/4
Trout	2/3
Salmon	2/3
Sole	3
Turbot	2/3
MEAT	
Beef	10/12
Mutton	6/8
Veal	9
Pork	6
Fillets/Chops	4
Liver/Kidneys	10
Brain/Tongue	2
Mincemeat, sausages	2
Rabbit	5/7
POUTRY AND GAME	
Chickens	10
Turkey (in portions)	7
Duck, goose	5
Hare	6
Partidrige-Quail	8
Pheasants	7/8
Big game	10
READY TO SERVE FOOD	
Tomato sauce	3
Stock	3
Beef, veal pork or chicken stews	2/3
Assorted vegetables	3
Stewed meat	3
Hamburguers	2
Stuffed peppers	2
Espinach	2
Brench beans	2
Tarts, confectionery, etc	5/6
Fruit salad	3
Sandwiches	6

SORT OF FOOD	Number of months
VEGETABLES	
Salt-wort	12
Artichoke	12
Carrots	12
Cauliflower	6/8
Brussels sprouts	6
Asparragus	12
Cabbage	6/8
Beans	12
Mushrooms	6
Parsley	12
Peppers	12
Spinach	12
Broad beans	12
FRUITS	
Apricots	8
Cherises, plums, raspberries, gooseberries, blackberries	10
Peaches	10/12
Strawberries	12
Stewed fruit (apples, pears)	10
Grapes	10/12
Fruit juices	10
Pineapple	10/12
BREAD CONFECTIONERY	
Biscuits-tarts	6
Flaky pastry tart	1
Pastry (unbaked)	3
Bread and rolls	2
EGGS AND DAIRY PRODUCE	
Eggs (shelled)	6
UHT Milk	3
Burter	6
Cheese (samall portions)	6/8
Fresh cream	3

USING THE FREEZER

DEFROSTING FOOD

The same method should not be used for defrosting all types of food.

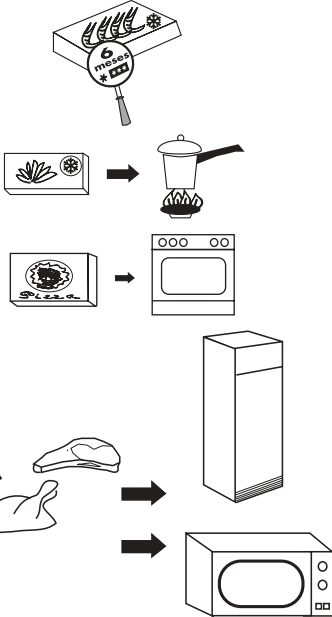

If you purchase frozen food from stores, follow the instructions on the packaging.

Green vegetables should be cooked without defrosting.

Pre-cooked and ready prepared food can generally be cooked without defrosting.

Meat and fish should be slowly defrosted in the refrigerator over several hours. If you have a microwave oven, defrosting can to a large extent be accelerated.

MAKING ICE CUBES

- 1** Fill the trays inside the freezer three quarters full of water.



- 2** Place the trays in the freezer, preferably in the top section.

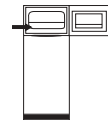

- 3** Once frozen, the ice cubes can be removed by gently twisting the trays.



USING THE FREEZER

DEFROSTING AND CLEANING

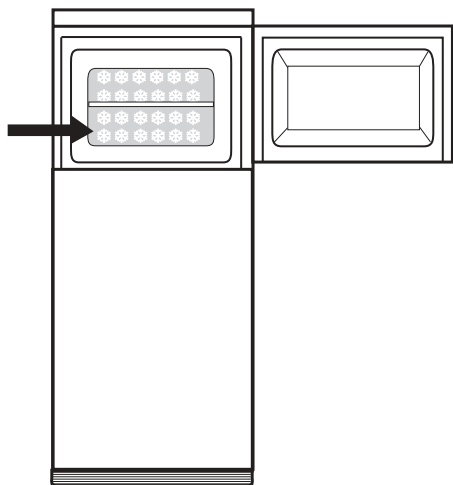

A layer of ice or frost will in time form on the walls of the freezer.

This will lead to an increased power consumption. In order to avoid this, the layer of ice should be removed at least twice each year.

- 1 Move the thermostat control to the STOP position and the freezer will be turned off.

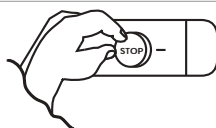

- 2 A scraper can be used to help remove the ice, or a container of hot water can be placed inside. Do not use sharp objects or electric heating devices.

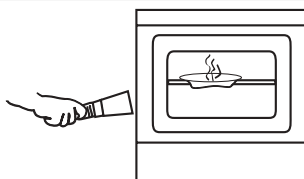

- 3 Collect the water which forms with an absorbent cloth and clean and dry the inside thoroughly.

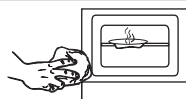

- 4 Move the thermostat control to the normal operating position.

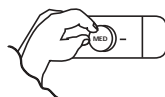

- 5 Two hours later the frozen food can be replaced in the freezer.

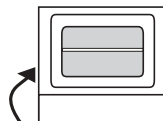

USING THE REFRIGERATOR

FOOD

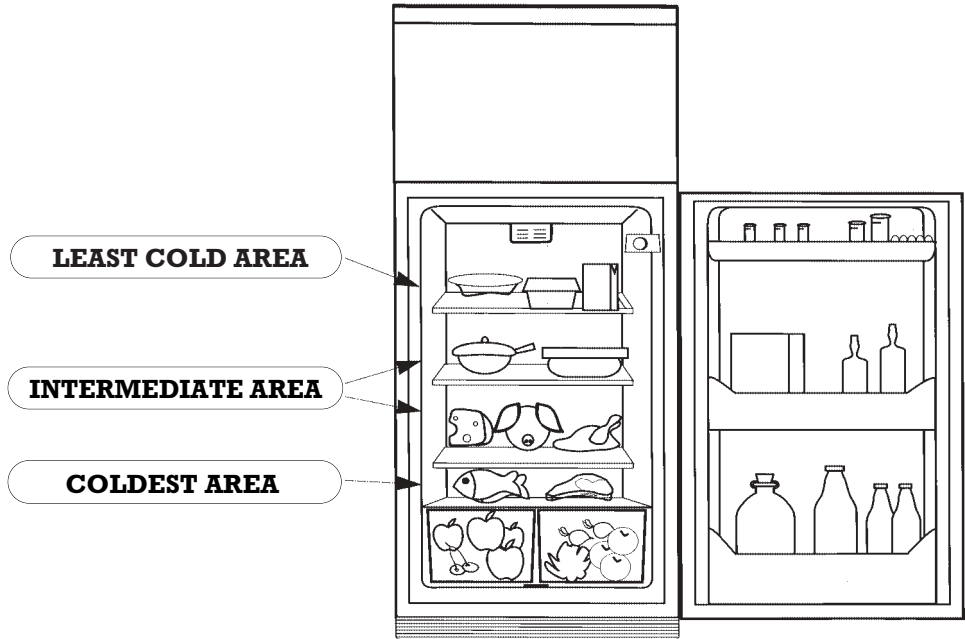

ATTENTION

- The temperature inside the refrigerator can be selected by turning the thermostat control.
- Remember that the temperature is not totally uniform within the interior as a whole and different sections are more suitable for different types of food (as shown in the diagram).
- The temperature inside the refrigerator can be affected by the ambient temperature, the location of the refrigerator and the frequency with which the door is opened. In the event of very high room temperatures, midrange setting of the thermostat will generate the best results.
- Do not place uncovered liquids or hot food in the refrigerator.
- NEVER place volatile, inflammable or explosive liquids in the refrigerator, such as solvents, alcohols, acetone or petrol as there will be a risk of explosion.
- Meat and fish should be wrapped to avoid smells developing.

USING THE REFRIGERATOR

DEFROSTING

The refrigerator has an automatic defrosting system and it is not therefore necessary to take any action.

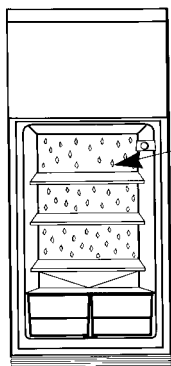

The back wall of the refrigerator is normally covered with drops of water or ice. This is completely **NORMAL** and is part of the automatic defrosting process.

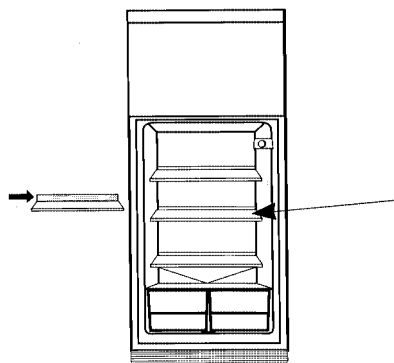

Ensure that foods does not touch the back wall. The trays have a limit point for this purpose which should not be exceeded.

USING THE FREEZER

FREEZING FRESH FOOD

NOTE

All the baskets in the freezer section of this refrigerator are in the ******** 4 star category and up to 4 kg of fresh food can be frozen in 24 hours.

ADVICE

- Wrap products to be frozen in aluminium foil or place them in sealed containers.
- Prepare foods in single consumption portions.
- Never refreeze food which has been defrosted.
- Label food with details of the contents and date frozen.
- Do not place food to be frozen in direct contact with food already frozen.
- Do not place fizzy drinks in the freezer section.
- Ice-cream, etc. should not be consumed at low a temperature.

DIRECTIONS FOR USE YOUR FREEZER

FROZEN FOOD PRESERVATION

A FEW HINTS

- When you buy frozen food in your shop, try to introduce the products into the freezer as soon as possible.
- Observe the preservation time that appear on the product packing, taking into account this a * *** freezer.
- When freezing food by yourself, consult the list of preservation times.

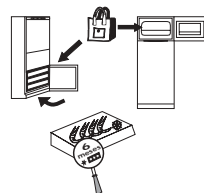

CONSERVATION TIMES

SORT OF FOOD	Number of months
FISH AND SHELLFISH	
Lobsters	3
Shrimps	3
Cold	2
Sardines and similar	3/4
Trout	2/3
Salmon	2/3
Sole	3
Turbot	2/3
MEAT	
Beef	10/12
Mutton	6/8
Veal	9
Pork	6
Fillets/Chops	4
Liver/Kidneys	10
Brain/Tongue	2
Mincemeat, sausages	2
Rabbit	5/7
POUTRY AND GAME	
Chickens	10
Turkey (in portions)	7
Duck, goose	5
Hare	6
Partidrige-Quail	8
Pheasants	7/8
Big game	10
READY TO SERVE FOOD	
Tomato sauce	3
Stock	3
Beef, veal pork or chicken stews	2/3
Assorted vegetables	3
Stewed meat	3
Hamburguers	2
Stuffed peppers	2
Espinach	2
Brench beans	2
Tarts, confectionery, etc	5/6
Fruit salad	3
Sandwiches	6

SORT OF FOOD	Number of months
VEGETABLES	
Salt-wort	12
Artichoke	12
Carrots	12
Cauliflower	6/8
Brussels sprouts	6
Asparragus	12
Cabbage	6/8
Beans	12
Mushrooms	6
Parsley	12
Peppers	12
Spinach	12
Broad beans	12
FRUITS	
Apricots	8
Cherises, plums, raspberries, gooseberries, blackberries	10
Peaches	10/12
Strawberries	12
Stewed fruit (apples, pears)	10
Grapes	10/12
Fruit juices	10
Pineapple	10/12
BREAD CONFECTIONERY	
Biscuits-tarts	6
Flaky pastry tart	1
Pastry (unbaked)	3
Bread and rolls	2
EGGS AND DAIRY PRODUCE	
Eggs (shelled)	6
UHT Milk	3
Burter	6
Cheese (small portions)	6/8
Fresh cream	3

USING THE FREEZER

DEFROSTING FOOD

The same method should not be used for defrosting all types of food.

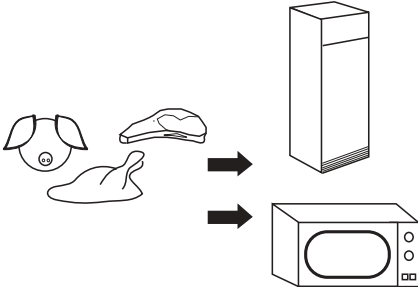
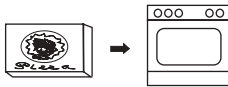
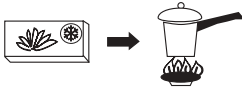
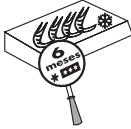

If you purchase frozen food from stores, follow the instructions on the packaging.

Green vegetables should be cooked without defrosting.

Pre-cooked and ready prepared food can generally be cooked without defrosting.

Meat and fish should be slowly defrosted in the refrigerator over several hours. If you have a microwave oven, defrosting can to a large extent be accelerated.

MAKING ICE CUBES

- 1 Fill the trays inside the freezer three quarters full of water.



- 2 Place the trays in the freezer, preferably in the top section.

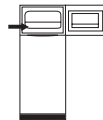

- 3 Once frozen, the ice cubes can be removed by gently twisting the trays.



USING THE FREEZER

DEFROSTING AND CLEANING

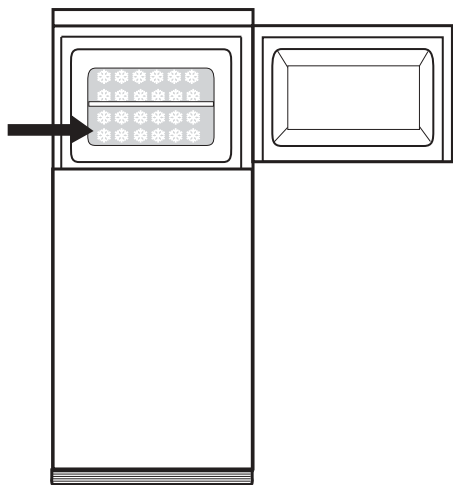

A layer of ice or frost will in time form on the walls of the freezer.

This will lead to an increased power consumption. In order to avoid this, the layer of ice should be removed at least twice each year.

- 1 Move the thermostat control to the STOP position and the freezer will be turned off.



- 2 A scraper can be used to help remove the ice, or a container of hot water can be placed inside. Do not use sharp objects or electric heating devices.

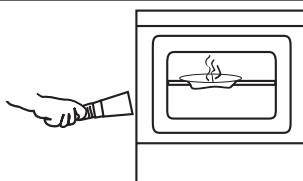

- 3 Collect the water which forms with an absorbent cloth and clean and dry the inside thoroughly.



- 4 Move the thermostat control to the normal operating position.

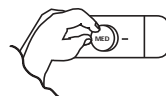

- 5 Two hours later the frozen food can be replaced in the freezer.

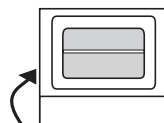

CLEANING AND MAINTENANCE

CLEANING

ADVICE

The refrigerator should be disconnected before cleaning the inside.

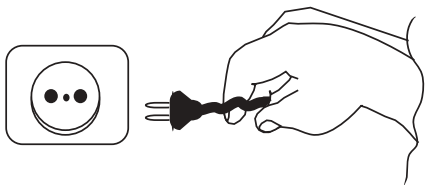

Do not use abrasive products, solvents, metal cleaning products or undiluted detergents.



The grill on the rear part of the refrigerator should be cleaned once a year with a vacuum cleaner. Dirt will prevent proper functioning increase electricity consumption.

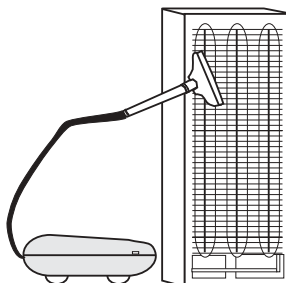

TEMPORARILY TURNING OFF THE REFRIGERATOR

- Disconnect the refrigerator.
- Remove food and clean and dry the inside.
- Leave the door open to avoid the formation of offensive odours.
- Follow the same procedure in the event of a prolonged power cut or refrigerator breakdown.

CHANGING THE BULB

1- Disconnect the refrigerator.

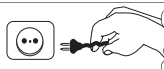

2- Remove the old bulb and replace with a similar type.

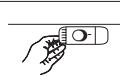

CHANGING THE DIRECTION OF DOOR OPENING

- 1 Lay the fridge down on its back.

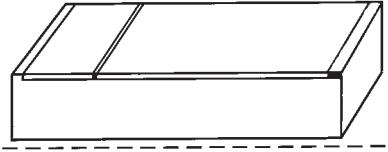

- 2 Remove the lower skirting, if any, from the refrigerator, as shown in the diagram. Then remove the left part of the skirting as shown to locate the lower hinge as shown in the diagram.

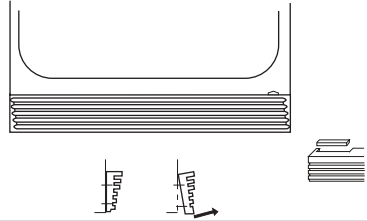

- 3 Remove the bottom hinge by undoing the 3 screws (A) holding it in place. Take out the pin (B) on the right-hand side and fit it to the left-hand side of the hinge. Undo the 2 screws (C) and screw them in the right-hand side. Take off the bottom door.

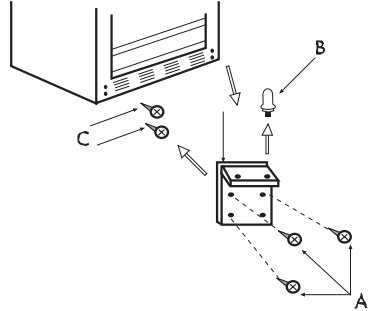

- 4 Remove the middle hinge, by removing the strip protecting and hiding the screws and then undoing the screws. Also remove the left-hand side cover and fit it where the hinge was before. Take off the top door.

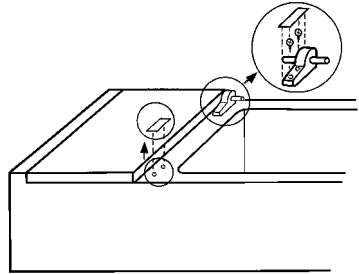

- 5 Take out the pin (D) on the right-hand side and fit on the left-hand side.

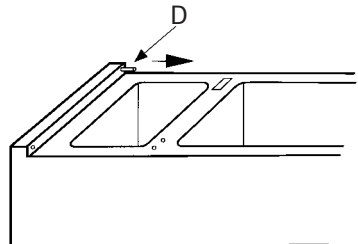

- 6** Remove the cover of the left-hand side lower door spindle and place it on the right-hand side (Panellable models do not have this cover).

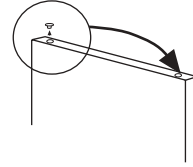

- 7** Put the top door back on, fitting it on the pin on the left-hand side.

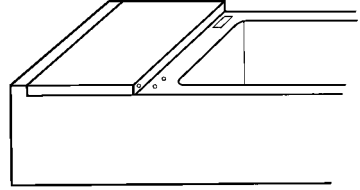

- 8** Fit the middle hinge on the left-hand pin on the top door and screw it to the fridge. Put the bottom door on, fitting it on the middle hinge pin. Then replace the strip to protect and hide the screws.

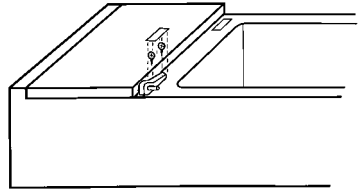

- 9** Fit the bottom hinge on the left-hand side and secure it with the 3 screws.

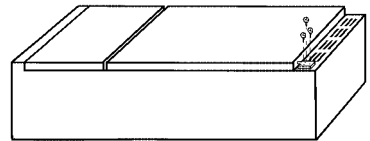

- 10** Replace the lower skirting.

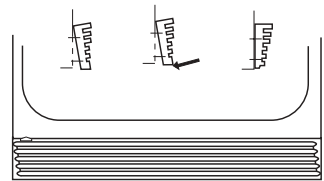

- 11** If your fridge accepts panels, the door handles should be changed from one side to the other.

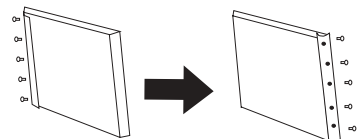

PROBLEMS

PROBLEM	POSSIBLE REASON	SOLUTION
The refrigerator is not working	The plug is not properly connected to the power supply.	Connect the plug.
	Electricity is not reaching the plug because a fuse has blown or an automatic circuit breaker has opened.	Change the fuse or reset the automatic circuit breaker.
The refrigerator does not get properly cold	The thermostat is set too low.	Turn the thermostat to a colder position.
	The door has not been closed properly or is opened too often.	Ensure that the door does not remain open for too long.
	The ventilation grill or the opening to the rear of the rear part of the refrigerator has been obstructed.	Keep these areas free as indicate in the Installation section of this manual.
	The refrigerator is in direct sunlight or exposed to a heat source.	Change the location of the refrigerator or protect it from heat sources.
Drops of water on the rear wall of the refrigerator	Automatic defrosting cycle.	Do not worry -this is completely normal (see section on Using the Refrigerator in this manual).
Water shows up of the bottom of the refrigerator	Food or a container has been placed in contact with the rear wall of the refrigerator.	Do not place food or containers in contact with the rear wall to avoid spillage of water formed when defrosting.
A large amount of ice forms on the walls and shelves of the freezer	The freezer door is obstructed and does not close properly.	Make sure that doors close properly by keeping them free from dirt and obstructions.
The refrigerator light does not come on	The plug is not properly connected to the power supply.	Connect the plug.
	Electricity is not reaching the plug because a fuse has blown or an automatic circuit breaker has opened.	Change the fuse or reset the automatic circuit breaker.
	The bulb is loose.	Insert properly.
	The bulb has blown.	Change the bulb as indicated in this manual.
Noisy operation	The refrigerator has not been properly levelled.	Level the refrigerator as indicated in the Installation section of this manual.
A bubbling noise	Operating cycle.	Do not worry -this is completely normal.
Food dries out	Food is not wrapped or placed in a container.	Wrap or place food in sealed containers.
Unpleasant smell inside the refrigerator	Food is not properly wrapped or in a container.	Wrap food or place it in a sealed container.
	The inside of the refrigerator needs cleaning.	Clean the refrigerator as shown in this manual.

TECHNICAL SERVICE

If you have carried out the above checks and the problem persists **DO NOT CARRY OUT ANY REPAIRS YOURSELF.**
Contact your nearest Technical Service.

ESPECIFICACIONES

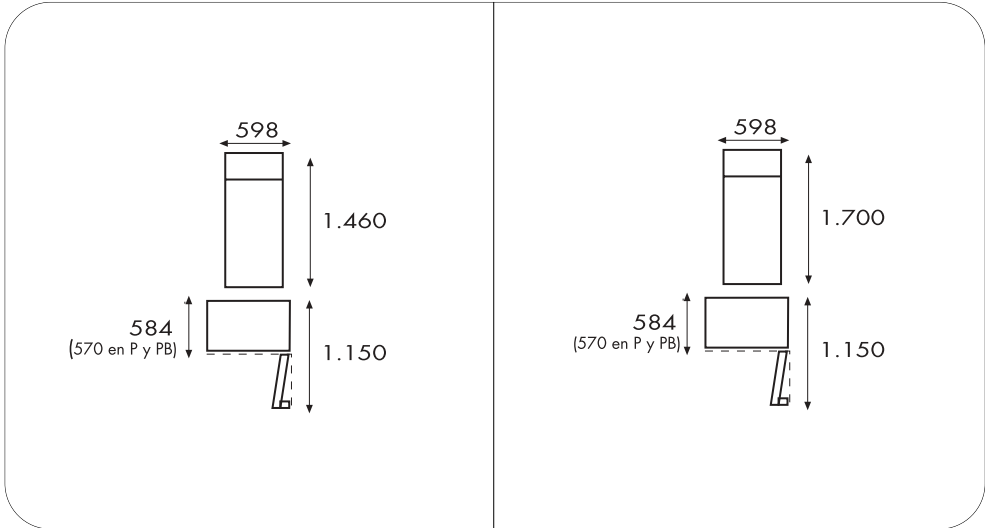

CE THESE APPLIANCES MEET
EEC DIRECTIVES: 73/23, 93/68, 89/336

INHALT

	Seite.
Installierung	2
Allgemeine Beschreibung.....	3
Benutzung des Kühlteils	4
Benutzung des Gefrierteils.....	6
Reinigung und Wartung	10
Wechsel des Türanschlags	11
Betriebsstörungen	13
Elektrische Schalttafel	14
Technische Daten	14

ACHTUNG

Wenn Ihr alter Kühlschrank mit automatischen oder manuellen Verriegelungsklinken ausgestattet ist, **VERGESSEN SIE NICHT DIE VERRIEGELUNG ZU VERNICHTEN ODER UNBRAUCHBAR ZU MACHEN**, bevor Sie ihn zum Sperrmüll geben. So wird verhindert, daß Kinder sich beim Spielen einschließen. **DIE ROHRE NICHT BESCHÄDIGEN**, um ein ungesteuertes Entweichen von Kühlmittel zu vermeiden.

INSTALLIERUNG

EMPFEHLUNGEN

Einen Luftumlauf auf der Rückseite des Kühlschranks ermöglichen. Weder das Vorgitter noch die Kühlschrankdecke mit Gegenständen abdecken. Wenn ein Schrank über dem Gerät angebracht wird, muß zur Belüftung ein Freiraum gelassen werden.

Möglichst die Nähe von Hitzequellen meiden.

Wenn der Kühlschrank zum Auspacken oder zum Wechseln des Türanschlags hingelegt werden muß, **NUR AUF DIE RÜCKSEITE LEGEN.**

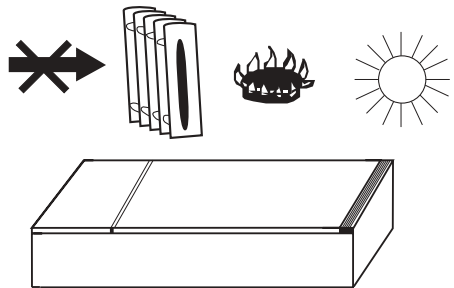

ANMERKUNG: die Türscharniere sind auf der rechten Seite angebracht. Wenn diese Stelle unbequem für Sie ist, können die Scharniere auf der anderen Seite angebracht werden. Im Anhang SEITENWECHSEL DER TÜRÖFFNUNG befinden sich die Anleitungen dazu.

Durch Einstellen der Nivellierbaren Füße ist sicherzustellen, daß der Kühlschrank gut (ohne zu hinken) und eben (nicht seitlich geneigt) auf der Stellfläche steht. **WICHTIG.**

Dieser Kühlschrank wird bei 220/230 V betrieben. Wenn die im Haus zur Verfügung stehende Spannung eine andere ist, muß eine Leistungstransformator mit eine Leistung von mind. 700 W verwendet werden. Verwenden Sie einen ERDANSCHLUSS. **ANMERKUNG:** Der Hersteller lehnt jede Haftung ab, wenn diese Empfehlungen nicht beachtet werden.

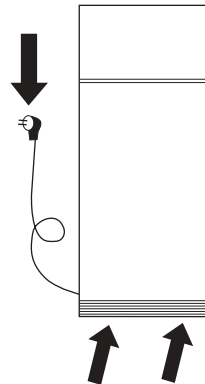

ACHTUNG: VOR DEM ANSCHLIESSEN

1.- Den Kühlschrank innen reinigen.



2.- Für einen einwandfreien Betrieb, erst nach Ablauf von 2 Stunden anschließen. ⌚

3.- Anschließen.



ALLGEMEINE BESCHREIBUNG

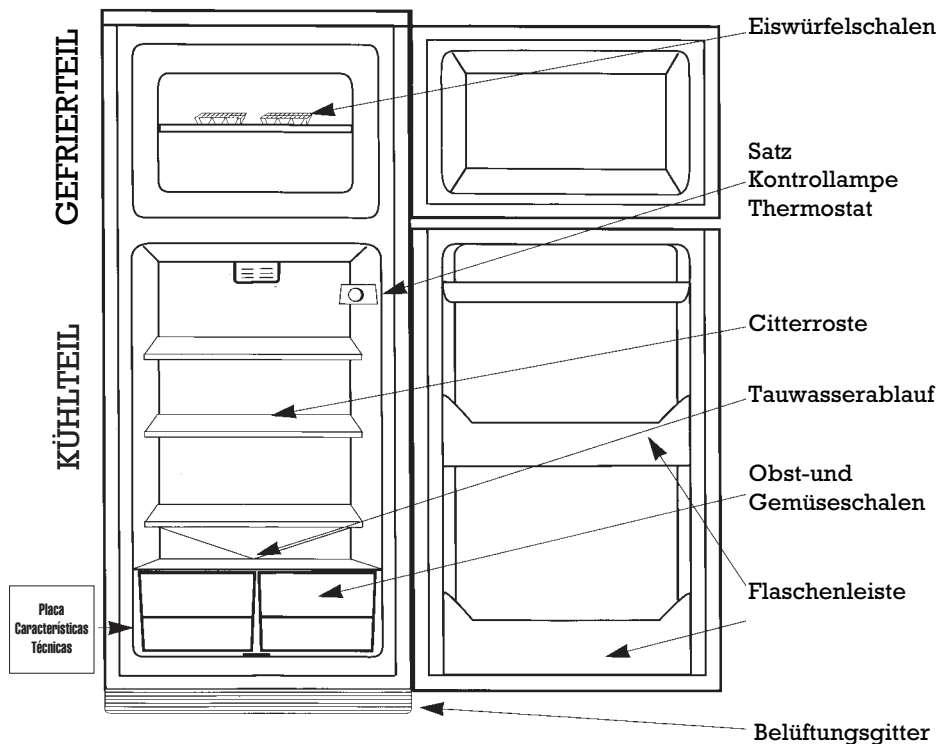

INBETRIEBNAHME

- 1** Thermostatregler betätigen und eine mittlere Stellung wählen.

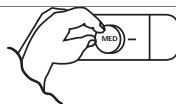

- 2** Türen Schliessen.

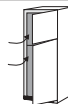

- 3** Nach 3 Stunden können Sie die Lebensmittel im Kühlteil aufbewahren. Bevor Sie Frischkost einfrieren können, müssen Sie 24 Stunden warten.

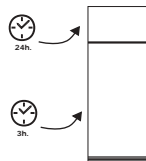

BENUTZUNG DES KÜHLTEILS

LEBENSMITTEL

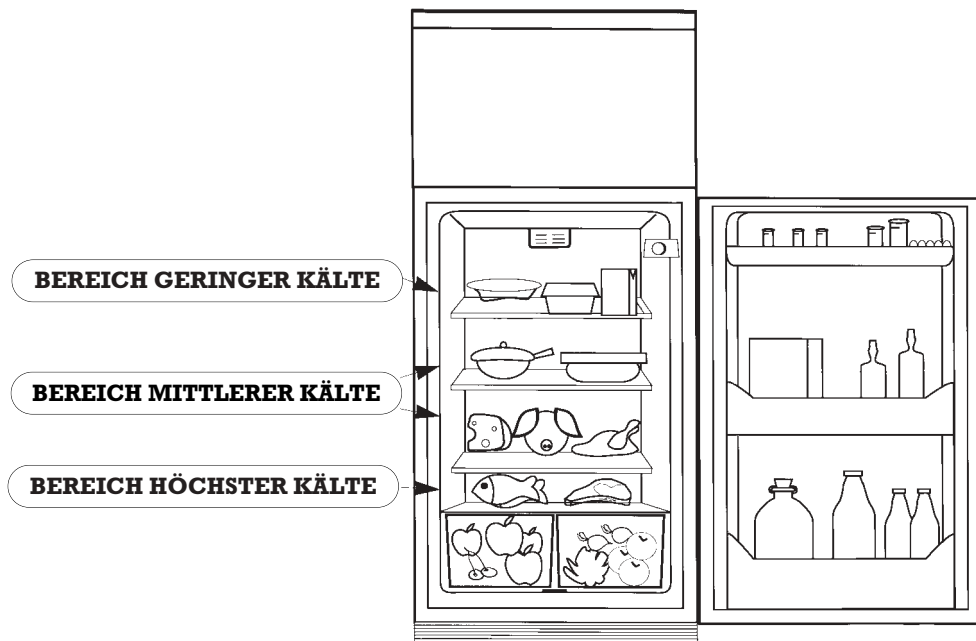

ACHTUNG

- Durch Drehen des Thermostatreglers kann eine stärkere oder schwächer Kühlung des Kühlteils eingestellt werden.
- Es ist zu beachten, daß nicht im ganzen Kühlraum die gleiche Temperatur herrscht, so daß es für jede Lebensmittelart einen entsprechenden Bereich gibt (siehe Abbildung).
- Die Kühlraumtemperatur kann durch die Raumtemperatur, die Aufstellung des Geräts und die Häufigkeit des Türöffnens beeinträchtigt werden. Bei hoher Zimmertemperatur wird der beste Erfolg erzielt, wenn sich der Thermostat in der Mittelstellung befindet.
- Niemals heiße oder nicht verschlossene flüssige Lebensmittel ins Kühlteil stellen.
- **NIEMALS** flüchtige, entzündbare oder explosive Flüssigkeiten, wie Lösungsmittel, Alkohole, Aceton oder Benzin in den Kühlraum stellen. Explosionsgefahr.
- Fleisch und Fisch sollten verpackt werden, um eine Geruchsbildung zu vermeiden.

BENUTZUNG DES KÜHLTEILS

ABTAUEN

Das Abtauen des Kühlteils erfolgt automatisch, also ohne jegliches Eingreifen des Benutzers.

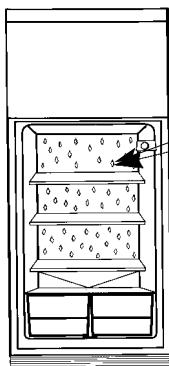

Die Rückwand des Kühlteils ist gewöhnlich mit kleinen Wassertropfen oder Eis bedeckt. Das ist vollkommen NORMAL und gehört zum Ablauf Abtauautomatik.

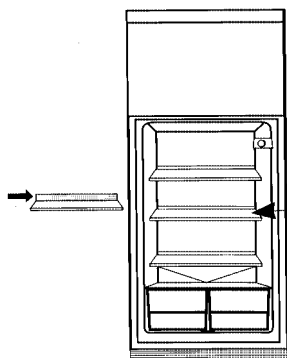

Die Lebensmittel sollten möglichst nicht mit der Rückwand in Berührung kommen. Dazu sind die Gitterroste mit einem Anschlag versehen der nicht überschritten werden sollte.

BENUTZUNG DES GEFRIERTEILS

EINFRIEREN VON FRISCHKOST

ANMERKUNG

Das Gefrierteil dieses Kühlschranks hat ******** 4-Sterne-Kategorie in jedem der Körbe, mit einem Gefriervermögen von bis zu 4 kg Frischkost in 24 Stunden.

EMPFEHLUNGEN

- Die einzufrierenden Produkte in Alufolie oder luftdichten Behältern verpacken.
- Die Lebensmittel in Portionen für den einmaligen Verbrauch zubereiten.
- Niemals bereits aufgetaute Lebensmittel wieder einfrieren.
- Ein Etikett, auf dem Inhalt und Einfrierdatum vermerkt sind, an der Verpackung anbringen.
- Die einzufrierenden Lebensmittel nicht mit den bereits gefrorenen in Berührung bringen.
- Keine kohlenensäurehaltigen Getränke im Gefrierteil aufbewahren.
- Speiseeis sollte nicht zu kalt verbraucht werden.

BENUTZUNG DES GEFRIERTEIL

KONSERVIERUNG TIEFGEKÜHLTER NAHRUNGSMITTEL

EMPFEHLUNGEN

- Wenn Sie tiefgekühlte Nahrungsmittel einkaufen, sorgen Sie dafür, dass die Pakete so schnell wie möglich in Ihren Gefriereteil kommen, damit sie nicht antauen.
- Achten Sie auf die auf der Verpackung der Tiefkühlkost angegebenen Konservierungszeit und bedenken Sie, dass dies ein * *** Gefriereteil ist.
- Wenn Sie Ihre selbstgekochten Speisen einfrieren wollen, beachten Sie bitte die Tabelle mit den Konservierungszeiten.

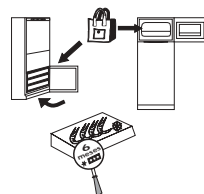

KONSERVIERUNGSZEITEN

ART DER NAHRUNGSMITTEL | Monate

FISCH UND MEERESFRÜCHTE	
Languste-Krustentiere	3
Krevetten-Garnelen	3
Seehecht	2
Fette Fischarten	3/4
Forelle	2/3
Lachs	2/3
Seezunge	3
Steinbutt	2/3
FLEISCH	
Rindfleisch	10/12
Hammefleisch	6/8
Kalbfleisch	9
Schweinefleisch	6
Koteletts, Steaks	4
Leber/Nieren	10
Hirn/Zunge	2
Hackfleisch, Würstchen	2
Kaninchen	5/7
GEFLÜGEL UND WILD	
Huhn-Hähnchen	10
Truthahn (zerteilt)	7
Ente, Gans,	5
Hase	6
Rebhuhn, Wachtel,	8
Fasan	7/8
Damhirsch, Hochwild	10
FERTIGE SPEISEN	
Tomatensoße	3
Fleischbrühe	3
Braten vom: Ochsen, Kalb, Hähnchen, Schwein	2/3
Gemischtes Gemüse	3
Gekochtes od. geschmortes Fleisch	3
Frikadellen	2
Gefüllte Paprikaschoten	2
Spinat	2
Grüne Bohnen, gekocht und sautiert	2
Pasteten, Torten usw	5/6
Obstsalat	3
Belegte Brote	6

ART DER NAHRUNGSMITTEL | Monate

GEMÜSE	
Mangold	12
Artischocken	12
Karotten	12
Blumenkohl	6/8
Rosenkohl	6
Spargel	12
Weißkohl	6/8
Grüne Bohnen	12
Pilze	6
Petersilie	12
Paprikaschoten	12
Spinat	12
Große Bohnen	12
OBST	
Aprikosen	8
Kirschen, Pflaumen, Himbeeren, Johannisbeeren, Brombeeren	10
Pfirsiche	10/12
Erdbeeren	12
Kompott (Äpfel, Birnen)	10
Weintrauben	10/12
Obstsaft	10
Ananas	10/12
BROT UND GEBÄCK	
Biscuit-Torten	6
Blätterteigtorte	1
Teig	3
Brot und Hefegebäck	2
EIER, MILCH UND MILCHPRODUKTE	
Eier (ohne Schale)	6
Homogenisierte Milch (Kartonverpackung)	3
Butter	6
Käse (kleine Portionen)	6/8
Frische Sahne	3

BENUTZUNG DES GEFRIERTEILS

AUFTAUEN VON LEBENSMITTELN

Nicht alle Lebensmittel sind in gleicher Weise aufzutauen.

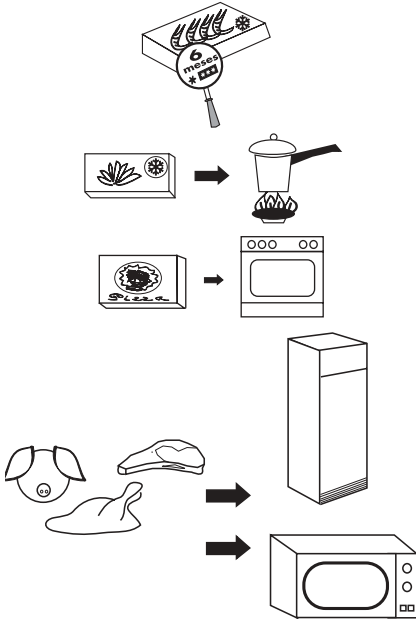

Wenn das Gefrierprodukt aus einem Geschäft stammt, befolgen Sie die Packungshinweise.

Gemüse wird direkt gegart.

Ganz allgemein können zubereitete oder vorgekochte Produkte direkt gegart werden.

Fleisch und Fisch müssen mehrere Stunden im Kühlschrank langsam aufgetaut werden. Wenn ein Mikrowellenherd vorhanden ist, kann das Auftauen erheblich verkürzt werden.

HERSTELLUNG VON EISWÜRFELN

1

Die im Innern des Gefrierteils befindlichen Eiswürfelschalen zu drei Vierteln mit Wasser anfüllen.



2

Die Eiswürfelschalen in das Gefrierteil, vorzugsweise in den unteren Teil desselben, einführen.

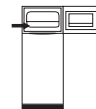

3

Nachdem das Wasser gefroren ist, können die Eiswürfel durch ein leichtes Verdrehen der Schalen herausgenommen werden.



BENUTZUNG DES GEFRIERTEILS

ABTAUEN UND REINIGUNG

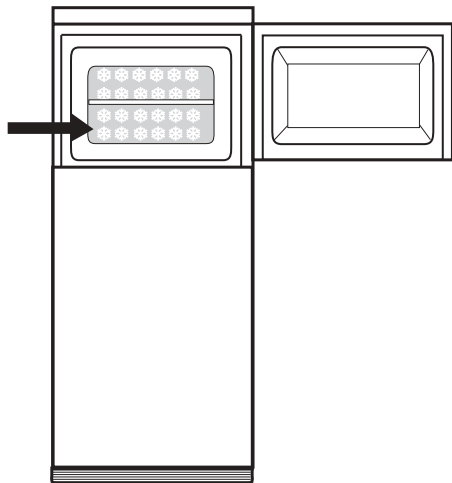

Mit der Zeit bildet sich an den Wänden des Gefrierteils eine Eis- bzw. -Reifschicht. Dies führt zu einem höheren Energieverbrauch Ihres Kühlschranks. Um dies zu vermeiden, muß diese Eischicht mindestens 2 Mal im Jahr entfernt werden.

- 1 Bringen Sie den Thermostatregler in die AUS-Stellung. Damit wird der Kühlschrank ausgeschaltet.



- 2 Der Eisentfernung kann mit Hilfe der Schaufel oder durch das Hineinstellen eines Behälters mit heißen Wasser nachgeholfen werden. Keine scharfen Gegenstände oder elektrischen Heizgeräte verwenden.

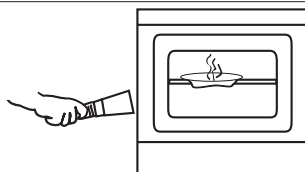

- 3 Tauwasser mit einem saugfähigen Tuch aufnehmen. Den Innenraum gut reinigen und trocknen.

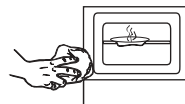

- 4 Thermostatregler wieder in die übliche Betriebsstellung drehen.

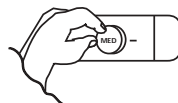

- 5 Nach 2 Stunden können Sie das Gefriergut wieder in das Gefrierenteil geben.

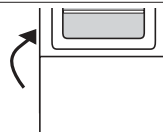

REINIGUNG UND WARTUNG

REINIGUNG

EMPFEHLUNGEN

Bevor Sie den Kühlschrank innen reinigen, muß er ausgeschaltet werden.

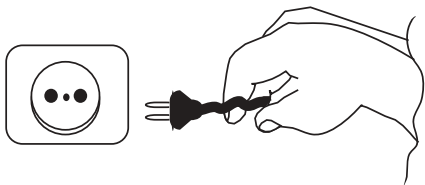

Keine ätzenden Lösungsmittel, Metallreinigungsmittel verwenden.

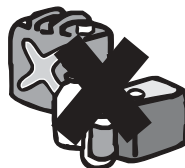

Einmal in Jahr sollte der Gitterrost auf der Rückseite des Kühlschranks mit dem Staubsauger gereinigt werden. Verschmutzung beeinträchtigt den Betrieb und erhöht den Stromverbrauch.

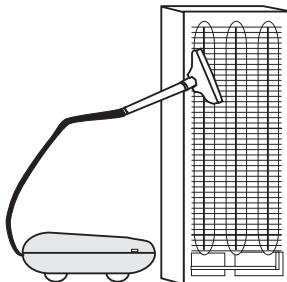

VORÜBERGEHENDS AUSSETZEN DES BETRIEBS

- . Kühlschrank abschalten.
- . Die Lebensmittel herausnehmen, innen gut reinigen und abtrocknen.
- . Die Tür offen lassen, um einer Geruchsbildung vorzubeugen.
- . Dasselbe ist bei längeren Stromausfällen oder Betriebsstörungen des Kühlschranks zu befolgen.

LAMPENWECHSEL

1- Kühlschrank abschalten.

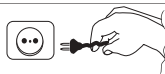

2- Die durchgebrannte Glühbirne herausnehmen und durch eine andere desselben Typs ersetzen.

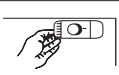

 220 v
15 w max.
E 14

WECHSEL DES TÜRANSCHLAGS

- 1 Den Kühlschrank mit der Rückseite nach unten auf den Boden legen.

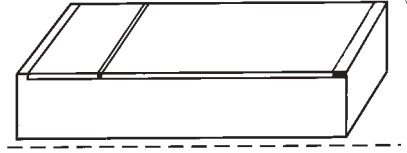

- 2 Falls der Kühlteil über einen Sockel im unteren Bereich verfügt, muß dieser entfernt werden. Anschließend die markierte linke Seite des Sockels aufritzen, um das untere Scharnier gemäß der Abbildung einzusetzen.

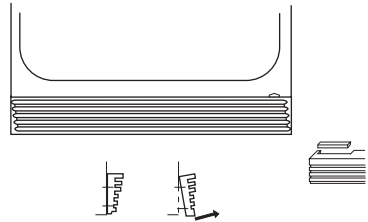

- 3 Durch Lösen der 3 Befestigungsschrauben (A) das untere Scharnier entfernen. Die Achse (B) aus der rechten Stellung in die linke Scharnierstellung führen und dort befestigen. Die beiden Schrauben (C) lösen und an der rechten Seite anziehen. Die untere Tür herausnehmen.

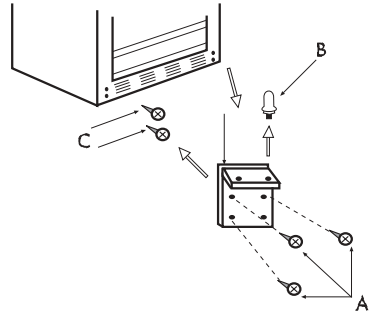

- 4 Nach Entfernen der Schraubenabdeckung die Schrauben lösen und das mittlere Scharnier entfernen. Die Klappe an der linken Seite wird ebenfalls abgenommen und dort angebracht, wo sich das Scharnier befindet. Die obere Tür abnehmen.

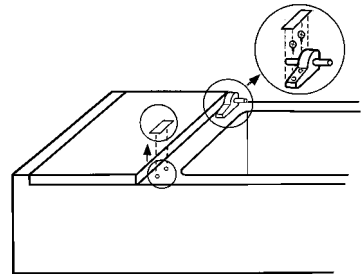

- 5 Die Achse (D) aus der rechten Stellung in die linke Stellung führen und dort befestigen.

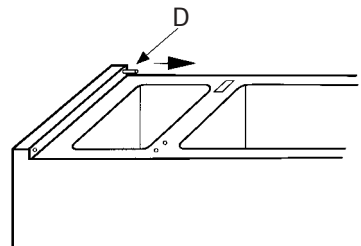

- 6** Remove the cover of the left-hand side lower door spindle and place it on the right-hand side (Panellable models do not have this cover).

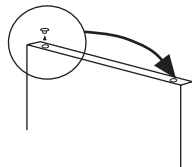

- 7** Put the top door back on, fitting it on the pin on the left-hand side.

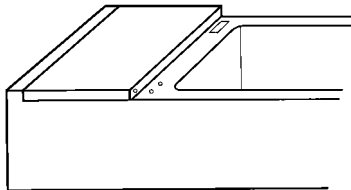

- 8** Fit the middle hinge on the left-hand pin on the top door and screw it to the fridge. Put the bottom door on, fitting it on the middle hinge pin. Then replace the strip to protect and hide the screws.

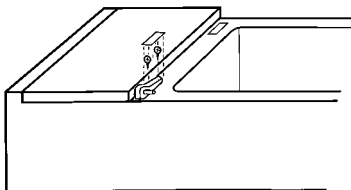

- 9** Fit the bottom hinge on the left-hand side and secure it with the 3 screws.

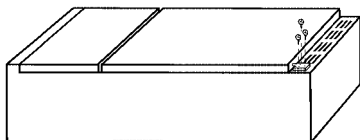

- 10** Replace the lower skirting.

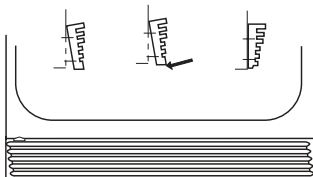

- 11** If your fridge accepts panels, the door handles should be changed from one side to the other.

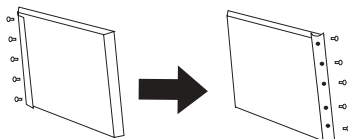

BETRIEBSSTÖRUNGEN

STÖRUNG	MÖGLICHE URSACHE	LÖSUNG
Der Kühlschrank funktioniert nicht	Der Stecker ist nicht ans Netz angeschlossen.	Stecker anschließen.
	Es gelangt kein Strom an den Anschluss, weil die Sicherung durchgebrannt, oder der automatische Leistungsbegrenzer herausgesprungen ist.	Sicherung auswechseln oder automatischen Leistungsbegrenzer wieder anschließen.
Der Kühlschrank kühlt schlecht	Die Thermostatsteuerung ist zu niedrig gestellt.	Den Thermostatregler auf kältere Einstellung drehen.
	Die Tür ist nicht richtig verschlossen gewesen oder ist häufig geöffnet worden.	Darauf achten, daß die Tür nicht lange offen bleibt.
	Belüftungsgrost oder hintere Deckenöffnung behindert.	Diese Bereiche, gemäß den Angaben von Kapitel "Installation" dieser Bedienungsanleitung, freihalten.
	Der Kühlschrank ist direkter Sonnenstrahlung oder einer Hitzequelle ausgesetzt.	Den Kühlschrank an einen anderen Ort stellen oder ihn vor diesen Hitzequellen schützen.
Wassertropfen auf der Rückenwand des Kühlschranks	Automatischer Abtaukreislauf.	Kein Grund zur Besorgnis: das ist vollkommen normal (siehe Kapitel "Benutzung des Kühlteils" dieser Bedienungsanleitung).
Es erscheint Wasser auf dem Boden des Kühlschranks	Es ist irgendein Lebensmittel oder Behälter direkt an der Rückenwand aufbewahrt worden.	Keine Lebensmittel oder Behälter direkt mit der Rückenwand in Berührung bringen. So wird das Ausfließen von Tauwasser vermieden.
Größere Einsparungen an den Kühlschrankwänden und-fächern	Die Tür des Gefrierteils ist versperrt und schließt nicht richtig.	Sorgen Sie für ein richtiges Abschließen der Tür durch Freihalten von Gegenständen oder Verschmutzung.
Die Kühlschranklampe leuchtet nicht auf	Der Stecker ist nicht ans Netz angeschlossen.	Stecker anschließen.
	Es gelangt kein Strom an den Anschluss, weil die Sicherung durchgebrannt oder der automatische Leistungsbegrenzer herausgesprungen ist.	Sicherung auswechseln oder automatischen Leistungsbegrenzer wieder anschließen.
	Die Glühbirne sitzt locker.	Richtig einschrauben.
	Die Birne ist ausgebrannt.	Glühbirne auswechseln, wie in dieser Bedienungsanleitung beschrieben.
Geräuschvoller Betrieb	Der Kühlschrank ist nicht richtig höhen eingestellt.	Einstellen, gemäß den Hinweisen im Kapitel "Installation" dieser Bedienungsanleitung.
Brodelergeräusch	Betriebskreislauf.	Kein Grund zur Besorgnis, das ist vollkommen normal.
Die Lebensmittel trocknen aus	Die Lebensmittel sind nicht verpackt oder abgedeckt.	Die Lebensmittel verpacken oder in luftdichten Behältern verschließen.
Geruchsbildung im Innern	Irgendein Lebensmittel ist nicht ausreichend verpackt oder abgedeckt. Das Innere des Geräts muß gereinigt werden.	Verpacken oder in luftdichten Behälter verschließen. Gemäß den entsprechenden Angaben dieser Bedienungsanleitung reinigen.

TECHNISCHER KUNDENDIENST

Wenn Sie alle oben genannten Punkte überprüft haben, und die Störung weiterhin besteht, NICHT SELBSTÄNDIG EINE REPARATUR DURCHFÜHREN.
Setzen Sie sich mit Ihrem nächsten Kundendienst in Verbindung.

ESPECIFICACIONES

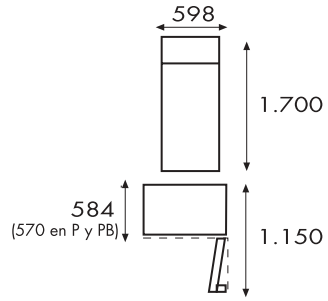
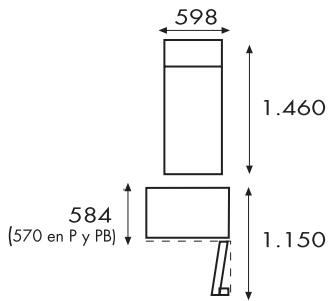

THESE APPLIANCES MEET
EEC DIRECTIVES: 73/23, 93/68, 89/336

INDICE

	Pag.
Installazione	2
Descrizione generale	3
Utilizzazione del refrigeratore	4
Utilizzazione del congelatore	6
Pulizia e manutenzione	10
Cambio di senso d'apertura delle porte	11
Problemi di funzionamento	13
Schema elettrico	14
Specificazioni	14

AVVERTENZA

Se il suo vecchio frigorifero dispone di chiavistelli di chiusura automatica o manuale, **NON TRALASCI DI DISTRUGGERE O INUTILIZZARE IL SISTEMA DI CHIUSURA** prima di inviarlo alla demolizione. In questo modo eviterà che i bambini giocando possano rimanere chiusi dentro.

NON DANNEGGI LE TUBATURE ed eviterà la fuga incontrollata all'atmosfera del refrigerante.

INSTALLAZIONE

RACCOMANDAZIONI

Permettere la circolazione d'aria nella parte posteriore del frigorifero.
Non tamponare la griglia davanti né sulla parte superiore del frigorifero con nessun oggetto. Se s'installa un armadio sopra, si lascerà un vano perchè circoli l'aria.

Evitare per tutto quanto possibile la vicinanza di fonti di calore.

Se ha necessità di disporre orizzontalmente il frigorifero per disimballarlo o per cambiare il senso d'apertura delle porte SI PUÒ STENDERLO APOGIANDOLO SOLAMENTE SULLA PARTE POSTERIORE.

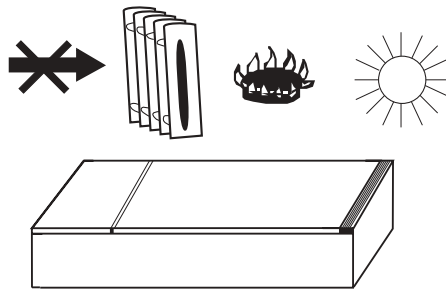

NOTA: Le cerniere delle porte si trovano nel lato destro. Se questa disposizione non è comoda per lei, è possibile cambiare il lato delle cerniere. Nell'annesso si trovano le istruzioni.

Regolando i piedi di livellamento, controllare che il frigorifero sia appoggiato bene sul pavimento (senza zoppicare e ben livellato (non in pendenza). **IMPORTANTE.**

Questo frigorifero funziona a 220/230v. Se lei ha una tensione diversa nella sua casa, deve utilizzare un trasformatore di potenza non inferiore a 700 W.

Utilizzi una spina con PRESA DI TERRA.

NOTA: Il fabbricante non assume nessuna responsabilità nel caso che non si seguano queste raccomandazione.

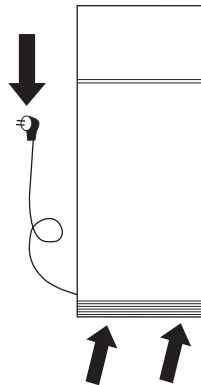

ATTENZIONE PRIMA CONNETTERE

1.- Pulire l'interno del frigorifero.



2.- Per un funzionamento corretto, aspettare due ore prima di connettere.



3.- Connettere.



DESCRIZIONE GENERALE

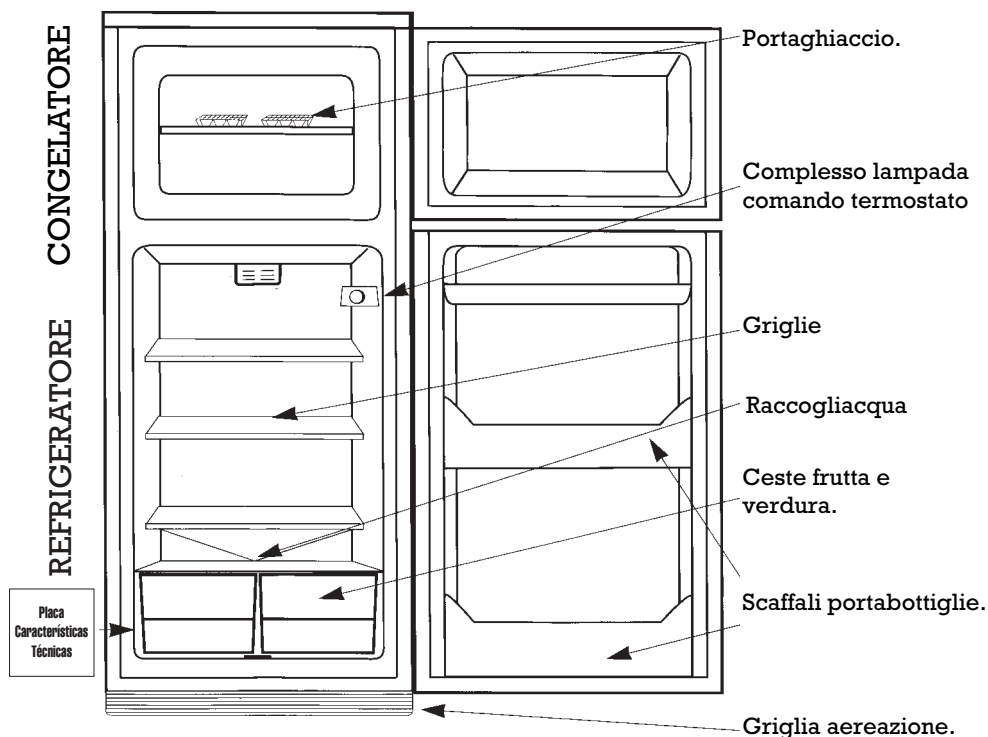

MESSA IN FUNZIONAMENTO

- 1** Azioni il comando termostato selezionando una posizione intermedia.

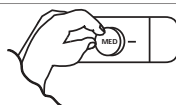

- 2** Chiuda le porte.

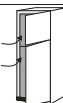

- 3** Dopo 3 ore può introdurre alimenti nel refrigeratore. Per congelare alimenti freschi aspetti 24 ore.

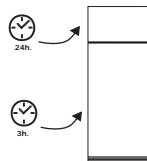

UTILIZZAZIONE DEL REFRIGERATORE

ALIMENTI

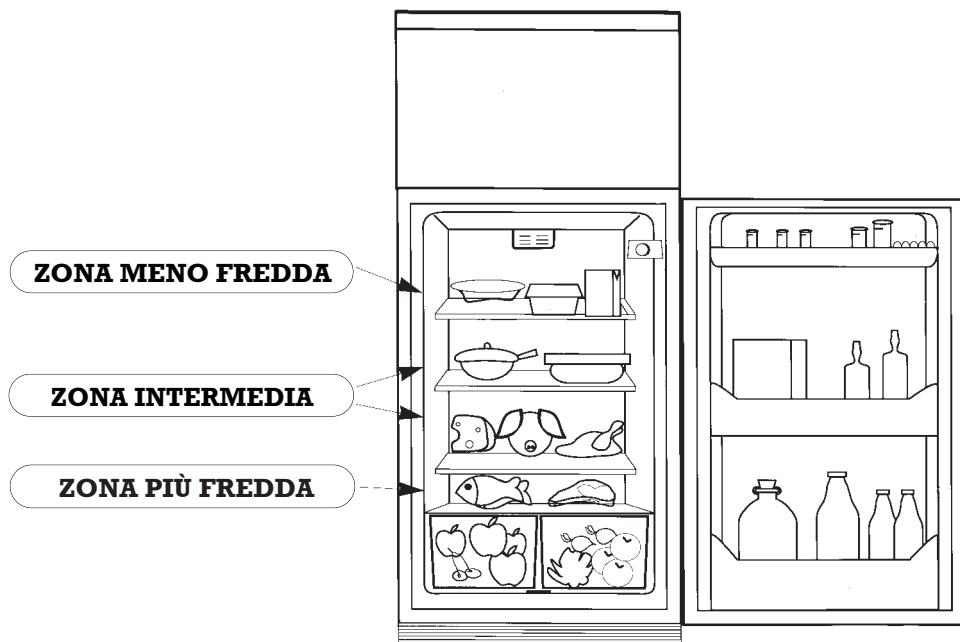

ATTENZIONE

- Girando il comando termostato si può selezionare più o meno freddo nel refrigeratore.
- Bisogna tener conto del fatto che la temperatura non è totalmente uniforme in tutto il recinto, per cui ci sono zone adeguate per ogni tipo di alimento (secondo la figura).
- La temperatura nel refrigeratore può risentire della temperatura ambiente, dell'ubicazione dell'apparato e della frequenza d'apertura della porta. Quando la temperatura ambiente è molto alta, otterra' il miglior rendimento con il termostato in posizione media.
- Non introdurre nel refrigeratore alimenti caldi o liquidi senza tamponare.
- Non introdurre MAI liquidi volatili, infiammabili o esplosivi, come solventi, alcool, acetone, o benzina. C'è il rischio d'esplosione.
- È conveniente avvolgere la carne ed il pesce per evitare cattivi odori.

UTILIZZAZIONE DEL REFRIGERATORE

SCONGELAMENTO

Il sistema di scongelamento del refrigeratore funziona automaticamente, pertanto non necessita nessun intervento dell'utente.

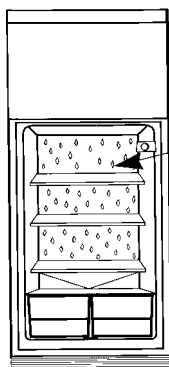

La parete del fondo del refrigeratore sarà abitualmente piena di gocce d'acqua o di ghiaccio. Questo è totalmente **NORMALE** e fa parte del processo automatico di scongelamento

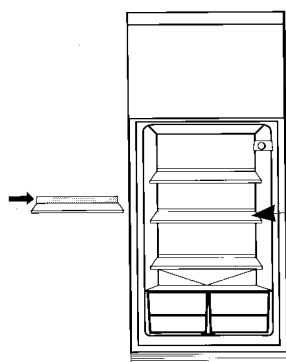

Faccia in modo che gli alimenti non tocchino la parete del fondo. Per questo le griglie dispongono di un limite che non deve essere superato.

UTILIZZAZIONE DEL CONGELATORE

CONGELAMENTO ALIMENTI FRESCHI

NOTA

Il congelatore di questo frigorifero è di categoria **★***** 4 stelle in qualunque cesta ed è capace di congelare fino a 4 kg di alimenti freschi in 24 ore.

CONSIGLI

- Avvolga i prodotti da congelare in carta d'alluminio o in recipienti ermetici.
- Prepari gli alimenti consumabili una sola volta.
- Non congeli mai una seconda volta un alimento scongelato.
- Collochi un'etichetta sull'involucro indicando il contenuto e la data di congelamento.
- Non metta gli alimenti da congelare a contatto diretto con quelli già congelati.
- Non immagazzini nel congelatore bevande gassose.
- I gelati non devono essere consumati troppo freddi.

UTILIZZAZIONE DEL CONGELATORE

CONSERVAZIONE DEI CIBI CONGELATI

CONSIGLI

- Quando acquisisce cibi congelati nei negozi, cerchi di far trascorrere meno tempo possibile fino alla loro introduzione nel congelatore.
- Faccia attenzione al tempo di conservazione riportato nelle confezioni dei prodotti congelati, tenendo presente che questo congelatore è di categoria * ** ** .
- Per i cibi da Lei congelati, consulti la tavola del tempo di conservazione.

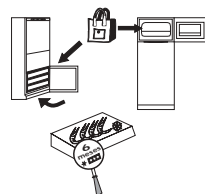

TEMPO DI CONSERVAZIONE

TIPO DI CIBI	Numero Mesi
PESCI E FRUTTI DI MARE	
Aragoste-crostacei	3
Gamberetti-Ganberi	3
Merluzzo	2
Pesce grasso	3/4
Trote	2/3
Salmoni	2/3
Sogliole	3
Rombi	2/3
CARNE	
Vaccino maggiore	10/12
Agnello	6/8
Vitello	9
Maiale	6
Bistecche/costolette	4
Fegato/reni	10
Cervella/lingua	2
Carne trita, salsice	2
Coniglio	5/7
GALLINACEI E CACCIA	
Galline-pollai	10
Taccino (a pezzi)	7
Anitra, oca domestica e selvatica	5
Lepri	6
Pernici-quaglie	8
Fagiani	7/8
Caccia maggiore	10
PIATTI PREPARATI	
Salsa di pomodori	3
Brodo di carne	3
Arrosti, bue, vitello, pollo, maiale	2/3
Minestra di verdure	3
Carne lessa, stufato	3
Ambrurger	2
Peperoni ripieni	2
Spinaci	2
Fagiolini verdi e soffritti	2
Torte, pasticci, ecc	5/6
Macedonia di frutta	3
Sandwich	6

TIPO DI CIBI	Numero Mesi
ORTAGGI	
Coste	12
Carciofi	12
Carote	12
Cavolfiori	6/8
Cavolini di brusela	6
Asparagi	12
Verza	6/8
Fagiolini	12
Funghi a cappello	6
Prezzemolo	12
Peperoni	12
Spinaci	12
Fave	12
FRUTTA	
Albicocche	8
Ciliege, prugne, lamponi, ribes, more	10
Pesche	10/12
Fragole	12
Composta (mele e pere)	10
Uva	10/12
Succhi di frutta	10
Ananas	10/12
PANE E PASTICCERIA	
Trancio-Torte	6
Torta a sfoglia	1
Pasta da pasticceria	3
Pane e focaccine	2
UOVA, LATTE E DERIVATI	
Uova (senza guscio)	6
Latte omogeneizzato (confezione di cartone)	3
Burro	6
Formaggi (piccole porzioni)	6/8
Panna fresca	3

UTILIZZAZIONE DEL CONGELATORE

SCONGELAZIONE DEGLI ALIMENTI

Non tutti alimenti devono essere scongelati nello stesso modo.

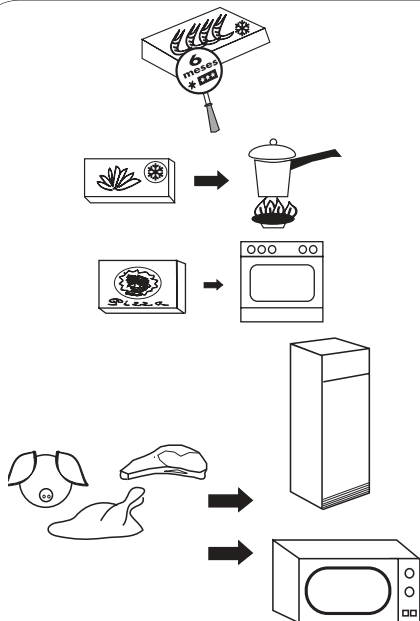

Se acquisti l'alimento congelato in commercio, segua le istruzioni del recipiente.

Le verdure devono essere cucinate direttamente.

In generale gli alimenti preparati o precotti possono essere cucinati direttamente.

Le carni ed il pesce devono essere scongelati lentamente nel refrigeratore per varie ore. Se dispone di forno microonda potrà accelerare in gran misura la scongelazione.

PRODUZIONE DI CUBETTI DI GHIACCIO

1

Riempia fino a tre quarti d'acqua i vassoi che troverá nell'interno del congelatore.



2

Introduca i vassoi nel congelatore, preferibilmente nella parte inferiore.

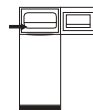

3

Dopo aver congelato l'acqua, può staccare i cubetti torcendo leggermente i vassoi.



UTILIZZAZIONE DEL CONGELATORE

SCONGELAMENTO E PULIZIA

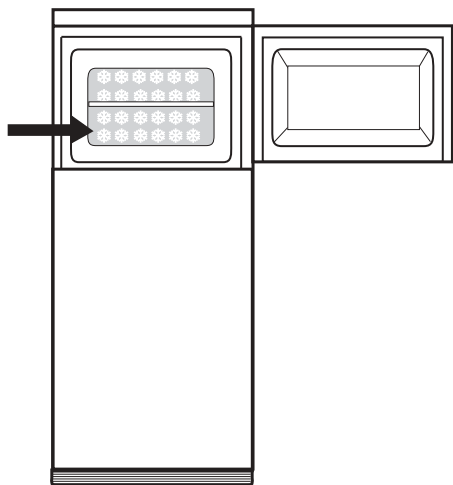

Con il tempo, sulle pareti del congelatore, si forma una cappa di brina o ghiaccio. Questo provocherà un maggior consumo di energia nel suo frigorifero. Per evitarlo, bisogna eliminare questo strato di ghiaccio, perlomeno due volte all'anno.

- 1** Collochi il comando termostato nella posizione STOP ed il frigorifero rimarrà sconnesso.

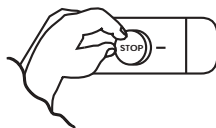

- 2** Può aiutare a eliminare il ghiaccio con la paletta o introducendo un recipiente con acqua calda. Non utilizzi oggetti affilati nè apparecchi elettrici di riscaldamento.

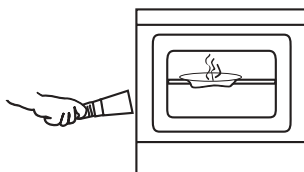

- 3** Ritiri l'acqua dello scongelamento con un panno assorbente, pulisca ed asciughi bene l'interno.

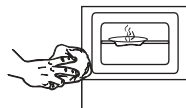

- 4** Azioni il mando termostato nella posizione abituale di funzionamento.

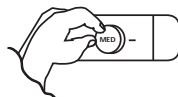

- 5** 2 ore più tardi può ritornare a introdurre gli alimenti congelati nel congelatore.

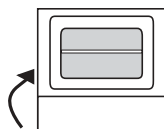

PULIZIA E MANUTENZIONE

PULIZIA

CONSIGLI

Per la pulizia dell'interno, il frigorifero deve essere sconnesso.

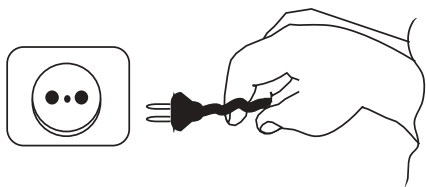

Non utilizzi prodotti abrasivi solventi, pulitori di metalli o detersivi non diluiti.



È conveniente pulire una volta all'anno con un aspirapolvere la griglia della parte posteriore del frigorifero. La sporcizia pregiudica il funzionamento ed aumenta il consumo di energia elettrica.

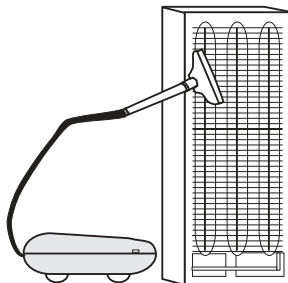

SCONNESSIONE TEMPORANEA DEL FRIGORIFERO

- . Sconnetta il frigorifero.
- . Estragga gli alimenti, pulisca e asciughi l'interno.
- . Lasci aperta la porta per evitare la formazione di cattivi odori.
- . Faccia lo stesso in caso di interruzione di corrente prolungata o di averia del frigorifero.

CAMBIO DI LAMPADA

1- Sconnettere il frigorifero.

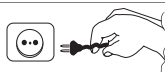

2- Estrarre la lampada bruciata e sostituirla con un'altra dello stesso tipo.

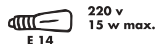
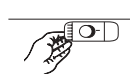

CAMBIO DI SENSO DELL'APERTURA DELLE PORTE

- 1 Appoggiare il frigorifero sulla parte posteriore.



- 2 Se il suo frigorifero ha lo zoccolo inferiore lo tolga così come viene indicato nella figura. Stacchi poi la parte sinistra marcata dello zoccolo la figura.

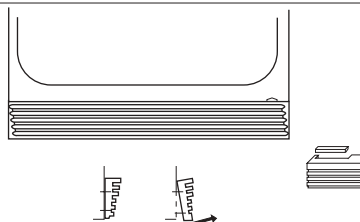

- 3 Estrarre la cerniera inferiore allentando le 3 viti di fissaggio (A): Estrarre l'asse (B) dalla posizione a destra e montarlo sulla posizione a sinistra della cerniera. Allentare le 2 viti (C) e avvitarle sul lato destro. Togliere la porta inferiore.

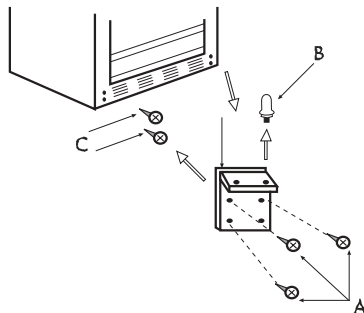

- 4 Estrarre la cerniera intermedia togliendo la piastrina protettiva che nasconde le viti e allentando le medesime. Estrarre anche il coperchietto dal lato sinistro e inserirlo al posto della cerniera. Togliere la porta superiore.

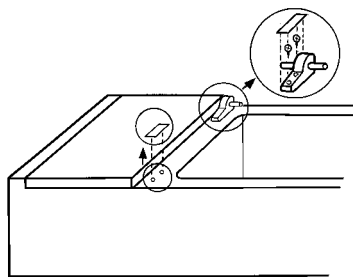

- 5 Estrarrà l'asse (D) dalla posizione a destra e montarlo sulla posizione a sinistra.

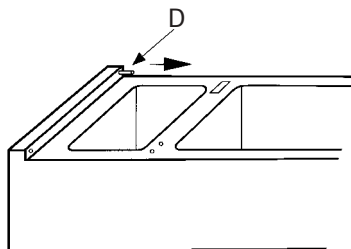

- 6** Stacchi il tappo dell'asse sinistro della porta inferiore e lo collochi nell'asse destro (i modelli pannellabili non hanno questo tappo).

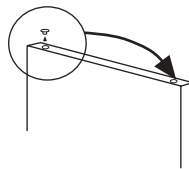

- 7** Mettere la porta superiore, inserendola sull'asse situato sul lato sinistro.

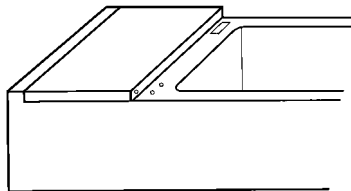

- 8** Mettere la cerniera intermedia sull'asse sinistro della porta superiore e avvitare al frigorifero. Mettere la porta inferiore inserendola sull'asse della cerniera intermedia. Inserire quindi la piastrina protettiva che nasconde le viti di fissaggio.

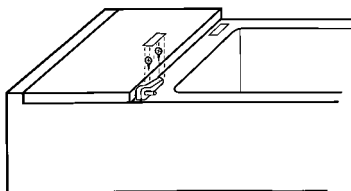

- 9** Inserire la cerniera inferiore sul lato sinistro e fissarla stringendo a fondo le 3 viti.

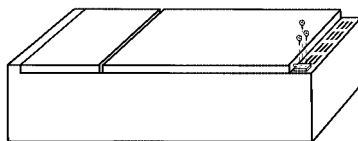

- 10** Collochi di nuovo lo zoccolo inferiore nella sua posizione.

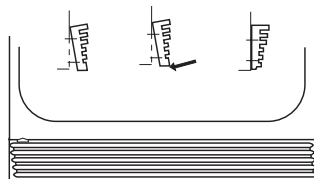

- 11** Se il frigorifero è pannellabile dovrà cambiare il lato dei tiranti delle porte.

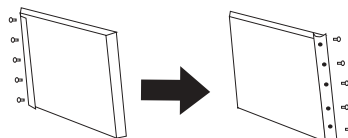

PROBLEMI DI FUNZIONAMENTO

PROBLEMA	CAUSA POSSIBILE	SOLUZIONE
Il frigorifero non funziona	La presa non è connessa alla presa di corrente.	Connettere presa.
	La corrente elettrica non raggiunge la presa essendosi fuso il fusibile o essendo saltato il limitatore automatico di potenza.	Cambiare il fusibile o riconnettere il limitatore automatico di potenza.
Il refrigeratore raffredda poco	Il comando del termostato si trova in una posizione bassa.	Giri il comando termostato a una posizione superiore di freddo.
	La porta è stata chiusa male o si è aperta con molta frequenza.	Aver cura che la porta non rimanga aperta per molto tempo.
	Si è otturata la griglia d'aerazione o l'apertura della parte posteriore della parte superiore.	Conservare libere queste zone secondo quanto viene indicato nel capitolo "Installazione" di questo manuale.
	Il frigorifero è spostato direttamente ai raggi del sole o a una fonte di calore.	Cambiare l'ubicazione del frigorifero o proteggerlo da queste fonti di calore.
Gocce d'acqua nella parete del fondo del refrigeratore	Ciclo automatico di scongelamento.	Non si allarmi: questo è completamente normale (vedere capitolo "Utilizzazione del refrigeratore" di questo manuale).
Si vede acqua nella base del refrigeratore	Si è collocato qualche alimento o recipiente attaccato alla parete del fondo del refrigeratore.	Non collochi alimenti o recipienti a contatto con la parete del fondo ed eviterà lo spargimento dell'acqua di scongelamento.
Molto ghiaccio nelle pareti e negli scaffali del congelatore	La porta congelatore non chiude bene essendo ostacolata.	Cerchi una buona chiusura delle porte mantenendole libere da oggetti o sporcizia.
La lampada del refrigeratore non si accende	La presa non è connessa alla presa di corrente.	Connettere la presa.
	Non giunge corrente elettrica alla presa essendosi fuso il fusibile o essendo saltato il limitatore automatico di potenza.	Cambiare il fusibile o ritornare a connettere il limitatore automatico di potenza.
	La lampada è lenta.	Avvitare correttamente.
	La lampada è fusa.	Cambiare la lampada secondo quanto viene indicato in questo manuale.
Funzionamento rumoroso	Il frigorifero non è stato livellato correttamente.	Livellare secondo quanto viene indicato nel capitolo "Installazione" di questo manuale.
Gorgoglio	Ciclo funzionamento.	Non si allarmi, questo è completamente normale.
Gli alimenti si seccano	Gli alimenti non sono avvolti o tappati.	Avvolgerli o introdurlo in recipienti ermetici.
Odori nell'interno	Qualche alimento non è correttamente avvolto o tappato.	Avvolgerlo o introdurlo in un recipiente ermetico.
	L'interno dell'apparato necessita una pulizia.	Pulire secondo quanto viene indicato in questo manuale.

SERVIZIO DI ASSISTENZA TECNICA

Se lei ha già effettuato i controlli indicati ed il suo problema persiste, **NON REALIZZI NESSU' ALTRA RIPARAZIONE PER PROPIO CONTO.**

Si metta a contatto con in servizio d'Assistenza Tecnica più vicino.

SPECIFICAZIONI

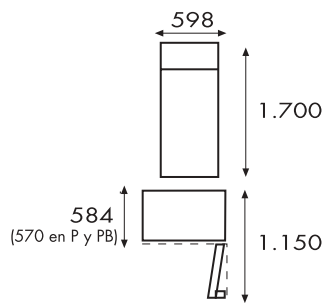
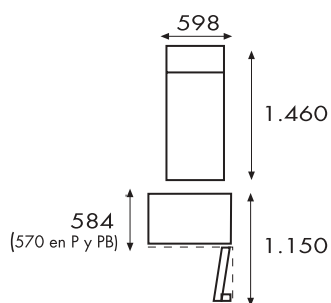

QUESTI APPARECCHI SODDISFANO I REQUISITI
DELLE DIRETTIVE CEE: 73/23, 93/68, 89/336

