

# **Belson**

***SERVICE***



***MANUAL***

## **BSV-29251**

# CONTENTS

SAFETY INSTRUCTION AND PRODUCT SAFETY NOTICE.....	1
X-RAY RADIATION PRECAUTION.....	1
SAFETY PRECAUTION.....	1
PRODUCT SAFETY NOTICE.....	2
ALIGNMENT PROCEDURE.....	3
TEST EQUIPMENT.....	3
ALIGNMENT INSTRUCTION.....	3
B+ CONFIRM.....	3
AGC ALIGNMENT.....	4
SOUND CHECK.....	4
FOCUS POTENTIOMETER ADJUSTMENT.....	4
H-CENTER ADJUSTMENT.....	4
V-SIZE, VERTICAL S-CORRECTION, V-CENTER, H-SIZE, E/W CORRECTION ADJUSTMENT.....	4
SCREEN-GRID VOLTAGE VG2 ADJUSTMENT.....	4
WHITE BALANCE ADJUSTMENT(AUTO DARK BALANCE).....	4
LUMINANCE/CHROMA TIME DELAY ADJUSTMENT.....	5
HIGH VOLTAGE AND FILAMENT VOLTAGE CHECK.....	5
X-RAY PROTECTION CHECK.....	5
BEAM CURRENT CHECK.....	5
AV FUNCTION CHECK.....	5
OUT-FACTORY STATUS SETTING.....	5
APPENDIX 1.....	6
APPENDIX 2.....	8
WIRING DIAGRAM.....	9
BLOCK DIAGRAM.....	10
IC BLOCK DIAGRAM.....	11
SCHEMATIC DIAGRAM.....	15
ELECTRICAL PARTS LIST.....	16

**CAUTION:** THIS SERVICE MANUAL IS ONLY FOR PROFESSIONAL SERVICE PERSONNEL'S REFERENCE. BEFORE SERVICING THIS CHASSIS, PLEASE READ THE FOLLOWING NOTICE ITEMS.

## **1. SAFETY INSTRUCTION AND PRODUCT SAFETY NOTICE**

Before servicing and aligning this equipment, please read the following “**X-RAY RADIATION PRECAUTION**”, “**SAFETY PRECAUTION**” and “**PRODUCT SAFETY NOTICE**”.

### **1.1 X-RAY RADIATION PRECAUTION**

- 1) Excessive high voltage can produce potentially hazardous X-RAY RADIATION. To avoid such hazards, the high voltage must not be above the specified limit. The normal value of the high voltage of this receiver is: 26.5kV(25”) at 1.3mA beam current; 29kV(29” super flat) at 1.4mA beam current; 30kV(29” pure flat) at 1.4mA beam current. The high voltage must not, under any circumstances, exceed 31kV(25”)/33kV(29”)/35kV(29” pure flat).
- 2) Each time a receiver requires servicing, the high voltage should be checked following the HIGH VOLTAGE CHECK procedure in this manual. It is recommended the reading of the high voltage be recorded as a part of service record. It is important to use an accurate and reliable high voltage meter.
- 3) The primary source of X-RAY RADIATION in this TV receiver is the picture tube. For continuous X-RAY RADIATION protection, the replacement tube must be exactly the same type tube as specified in the parts list.
- 4) Some parts in this receiver have special safety-related characteristics for X-RAY RADIATION protection. For continuous safety, parts replacement should be undertaken only after referring to the PRODUCT SAFETY NOTICE below.

### **1.2 SAFETY PRECAUTION**

#### **WARNING:**

Service should not be attempted by anyone unfamiliar with the necessary precaution on this receiver. The following are the necessary precautions to be observed before servicing this chassis.

- 1) Since the power supply circuit of this receiver is directly connected to the AC power line, an isolation transformer should be used during any dynamic service to avoid possible shock hazard.
- 2) Always discharge the picture tube anode to the CRT conductive coating before handling the picture tube. The picture tube is highly evacuated and if broken, glass fragments will be violently expelled. Use shatter proof goggles and keep picture tube away from the unprotected body while handling.
- 3) When replacing a chassis in the cabinet, always be certain that all the protective devices are put back in place, such as: non-metallic control knobs, insulating covers, shields, isolation resistor-capacitor network etc.
- 4) When replacing parts or circuit boards, disconnect the power cord.
- 5) When replacing a high wattage resistor (oxide metal film resistor) on the circuit board, keep the resistor 10mm (1/2in) away from circuit board.

- 6) Connection wires must be kept away from components with high voltage or high temperature.
- 7) If any fuse in this TV receiver is blown, replace it with the FUSE specified in the chassis parts list.
- 8) Before returning the set to your customer, always perform an AC leakage current check on the exposed metallic parts of the cabinet, such as antennas, terminals, screwheads, metal overlays, control shafts etc. to be sure the set is safe to operate without danger of electrical shock. Plug the AC power cord into a 220V AC outlet (do not use a line isolation transformer during this check). Use an AC voltmeter having 5000 ohms per volt or more sensitivity in the following manner:

Connect a 1500 ohm 10 watt resistor, paralleled by a 0.15 $\mu$ F, AC type capacitor, between a known good earth ground (water pipe, conduit, etc.) and the exposed metallic parts, one at a time. Measure the AC voltage across the combination of 1500 ohm resistor and 0.15 $\mu$ F capacitor. Reverse the AC plug at the AC outlet and repeat AC voltage measurements for each exposed metallic part. Voltage measured must not exceed 0.3 volts RMS. This corresponds to 0.2 milliamp. AC. Any value exceeding this limit constitutes a potential shock hazard and must be corrected immediately.

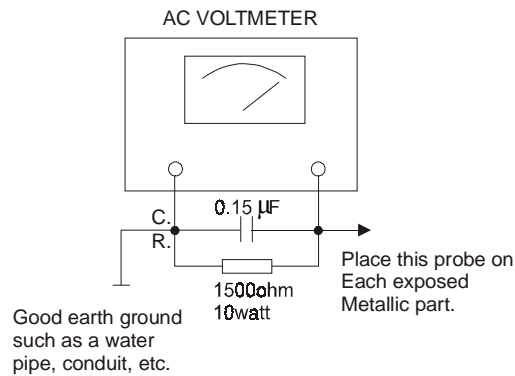

- 9) DC voltage breakdown test

Before packing, the following touchable parts should be conducted with withstand voltage test for 1s. Apply the voltage and test, the voltage should be AC 3000V.

Part name :	Position:
Antenna terminal	Back cabinet
Outcabinet screws	Back cabinet
AV terminals	Back and side

### 1.3 PRODUCT SAFETY NOTICE

Many electrical and mechanical parts in the chassis have special safety-related characteristics. These characteristics are often passed unnoticed by a visual inspection and the X-RAY RADIATION protection afforded by them cannot necessarily be obtained by using replacement components rated for higher wattage, etc. Replacement parts which have these special safety characteristics are identified in this manual and its supplement electrical components having such features are shaded on the schematic diagram and the parts list.

Before replacing any of these components, read the parts list in this manual carefully. The use of substitute replacement parts which do not have the same characteristics as specified in the parts list may create shock, fire, X-RAY RADIATION or other hazards.

## 2 Alignment procedure

The alignment procedure flow chart see below figure:

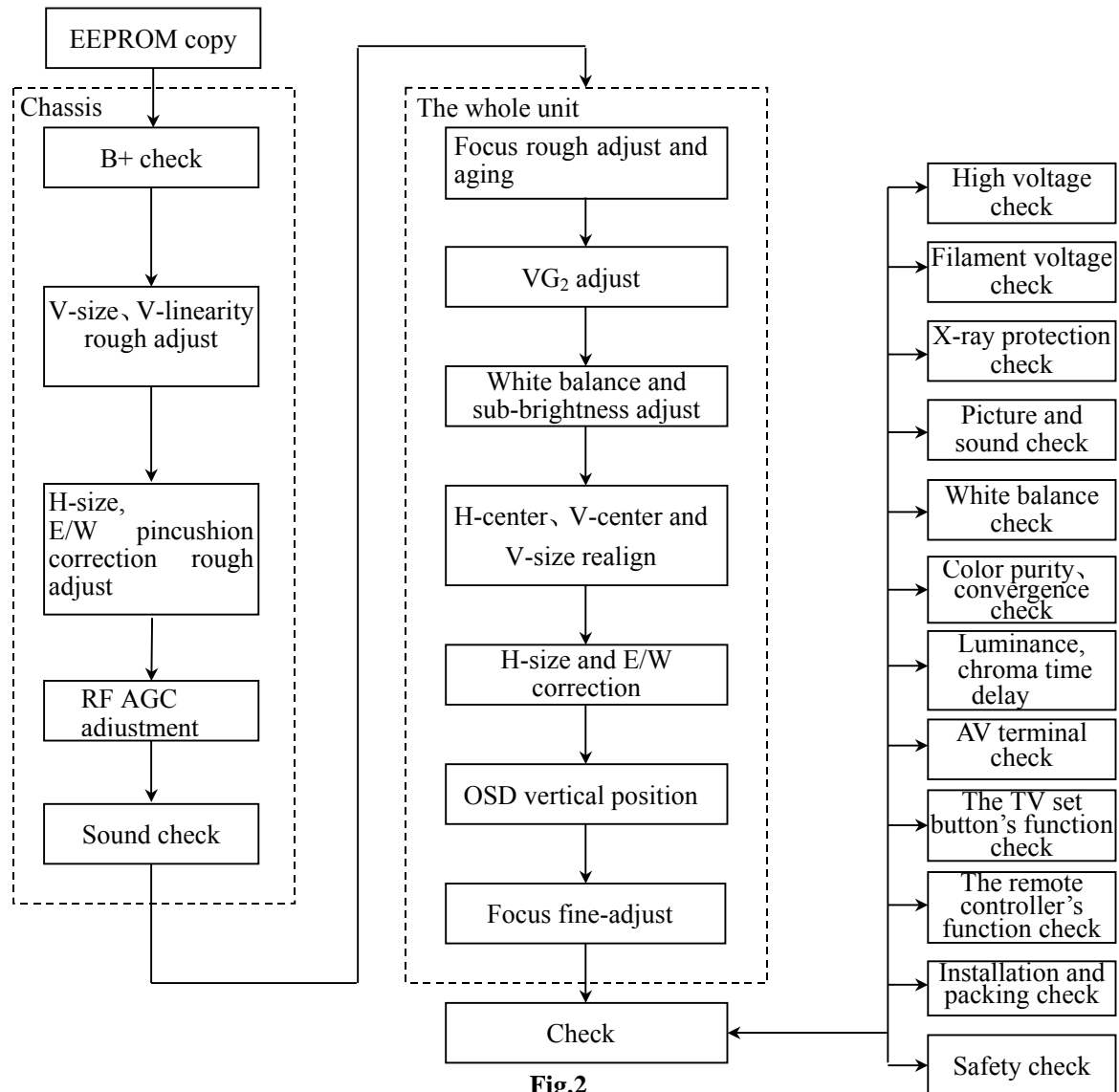

**Fig.2**

## 3. TEST EQUIPMENT

- 3.1 DC regulated power supply PAB18-1.8
- 3.2 Audio voltmeter
- 3.3 Oscilloscope
- 3.4 High-voltage meter
- 3.5 Digital multimeter
- 3.6 AC break-down testing equipment

## 4 Alignment instruction

The way to enter into factory alignment menu by using remote control: when there is no OSD on the screen, in turn press MIX, CANCEL, HOLD and REVEAL button and the period of two-press should be less than 3 seconds. To exit, press TV button.

### 4.1 B+ confirm

Use DC voltmeter of DC200V to check B+ voltage (C529 two terminals), 29" pure flat CRT should be 140V or 138V (depending on different CRT), the error is  $\pm 0.5$  V.

### 4.2 AGC alignment

## 4.2 AGC alignment

4.2.1 Receive D-8 signal 60 dB, use DC voltameter to measure C104 positive pole testing point voltage.

4.2.2 Adjust TOP item to make AGC voltage just start dropping from highest point (about 4V).

4.2.3 From antenna input inputs 100 dB signal, the picture should not appear non-synchronization and distortion. Input 35 dB~40 dB weak signal, the colour should not appear and picture is in synchronization and sound is normal.

## 4.3 Sound check

4.3.1 Receive 1kHz 100% modulation sound signal, XV03 connect with a simulated speaker load of 8 ohm, audio voltmeter or oscilloscope measure the voltage of the load.

4.3.2 Turn the volume to maximum, the sound power consumption should be  $\geq 7 W \times 2$  (about 7.5 Vrms), the distortion should be  $\leq 7\%$  (allow maximum volume sine wave have clipping distortion).

## 4.4 Focus potentiometer adjustment

4.4.1 The whole unit preheats 30 minutes.

4.4.2 Receive testing signal.

4.4.3 Press PP button to select DYNAMIC mode.

4.4.4 Adjust FBT's FOCUS potentiometer to make picture clearest.

## 4.5 H-center adjustment

4.5.1 Receive 50 Hz testing signal.

4.5.2 Enter into 5HSH item, adjust the level to make picture symmetry in horizontal.

4.5.3 Receive 60Hz testing signal. To 6HSH adjust, the method is as same as the above two steps.

4.6 **V-size, Vertical S-correction, V-center, H-size, E/W correction adjustment** (50 Hz/60 Hz independently)

4.6.1 Receive testing signal, enter into factory menu VSL item, adjust the value to make picture's lower half part just disappear.

4.6.2 Enter into factory menu corresponding item, adjust the value to make V-center and CRT's geometrical center be in accordance, vertical S-linearity be proper and vertical reproduction rate be  $\geq 90\%$ .

4.6.3 Enter into factory menu corresponding items, adjust horizontal geometrical distortion until be in proper.

EWV Adjust H-size

EWP Adjust east/west pincushion correction size

EWT Adjust east/west trapezoid size

UCT Adjust east/west left upper corner and right upper corner distortion

LCR Adjust east/west left lower corner and right lower corner distortion.

BOW Adjust east/west arch.

PAR Adjust parallelogram.

The adjustment results meet scan linearity geometrical distortion and over-scan (reproduction rate) requirements.

## 4.7 Screen-grid voltage VG2 adjustment

Enter into factory menu, set VG2B to 29, press digit button "0", enter into alignment status, turn FBT accelerated pole potentiometer to end anticlockwise, then clockwise turn the potentiometer until the indication "OUTSIDE LOW" just jump to "INSIDE HIGH".

## 4.8 White balance adjustment (auto dark balance)

4.8.1 Dark balance just need fine tune, under 4.5 nit, colour temperature 12000K+8MPCD (X=0.270, Y=0.283)

4.8.2 Bright balance also has already automatically adjusted at some white coordinate. Only need to fine tune around 31 value, under 60 nits, colour temperature 12000K+8MPCD (X=0.270, Y=0.283)

#### 4.9 Luminance/chroma time delay adjustment (YD\_ \_)

Respectively input PAL,SECAM,NTSC RF signal or PAL AV signal and adjust YD\_ \_ to make luminance tallied with chroma.

For those model with SVM function, on the condition that SVM is set to ON, input split field or crosshatch signal, respectively adjust YD\_ \_ until SVM's edge from black to white is in symmetry with that from white to black, give attention to the data that make luminance tallied with chroma.

#### 4.10 High voltage and filament voltage check

4.10.1 Connect high voltage meter between CRT high voltage cap and GND, use effective and precise voltmeter to measure filament voltage.

4.10.2 Receive D35 signal, set picture mode to "DYNAMIC". Measure the high voltage and filament voltage and the reading should be: for 29" super flat CRT, the high voltage is  $29\text{ kV} \pm 0.5\text{ kV}$ , for 29" pure flat CRT, the high voltage is  $30\text{ kV} \pm 0.5\text{ kV}$ , filament voltage  $6.3 \pm 0.3\text{ Vrms}$ .

#### 4.11 X-ray protection check

4.11.1 Receive normal picture.

4.11.2 Press S301 switch, horizontal scan should stop vibration and turn off.

4.11.3 Turn off the power switch and wait about 30 seconds, turn on the set again, it should restore to normal.

#### 4.12 Beam current check

Receive D35 signal, set picture mode to "DYNAMIC", measure R313 two terminals, for 29" super flat it should be  $\leq 1.6\text{ V}$ , for 29" pure flat it should be  $\leq 1.7\text{ V}$ .

#### 4.13 AV function check

According to Instruction manual, connect the AV equipment to the AV terminals which need to be check, the following is required:

VIDEO IN:  $1\text{ Vp-p } 75\ \Omega$ , AUDIO IN:  $-8\text{ dBm} \pm 3\text{ dBm } >47\text{ k}\ \Omega$ .

#### 4.14 Out-factory status setting

Contrast:	45	Comb filter:	ON
Brightness:	28	Blue back:	ON
Colour:	40	Black stretch:	ON
Sharpness:	35	SVM:	ON
Treble:	31	AVL:	OFF
Bass:	31	Surround:	OFF
Balance:	0		

The following appendix is factory menu and data.

### Appendix 1 factory menu and data

Page/ Button	Item	Meaning	Reference value	Remark		
1	5PAR	Horizontal parabola	0-63	For 50Hz		
	5BOW	Horizontal bow	0-63			
	5HSH	Horizontal shift	0-63			
	5EW W	EW width	0-63			
	5EWP	EW parabola	0-63			
	5UCR	EW upper corner parabola	0-63			
	5LCR	EW lower corner parabola	0-63			
2	5EWT	EW trapezium	0-63			
	5VSL	Vertical slope	0-63			
	5VAM	Vertical amplitude	0-63			
	5SCL	S-Correction	0-63			
	5VSH	Vertical Shift	0-63			
	5VOF	Text Position Vertical offset	<b>41</b>			
1	6PAR	Horizontal parabola	0-63	For 60Hz		
	6BOW	Horizontal bow	0-63			
	6HSH	Horizontal shift	0-63			
	6EW W	EW width	0-63			
	6EWP	EW parabola	0-63			
	6UCR	EW upper corner parabola	0-63			
	6LCR	EW lower corner parabola	0-63			
2	6EWT	EW trapezium	0-63			
	6VSL	Vertical slope	0-63			
	6VAM	Vertical amplitude	0-63			
	6SCL	S-Correction	0-63			
	6VSH	Vertical Shift	0-63			
	6VOF	Text Position Vertical offset	<b>28</b>			
3	VX	Vertical Zoom	<b>25</b>	Adjust around 31		
	RED	Black level offset R	32			
	GRN	Black level offset G	32			
	RED	WPR	White Point R		0-63	
	GREE N	WPG	White Point G		0-63	
	BLUE	WPB	White Point B		0-63	
		YDFP	Y-Delay for PAL		0-15	Brightness, colour in accordance. For model with SVM function, SVM edge should be in symmetrical.
		YDFN	Y-Delay for NTSC			
		YDFS	Y-Delay for SECAM			
		YDAV	Y-Delay for AV			
4	TOP	AGC Take-Over Point	0-63			



	VOL	Volume	<b>45</b>	
	9874	Gain control for TDA9874	<b>20</b>	
	IFFS	Vision IF	<b>2</b>	2-38.9M,3-38M
	HDOL	Cathode drive level	<b>8</b>	
	AGC	IF AGC speed	<b><i>1</i></b>	
	AG2B	VG2 Brightness	33	Before adjust AG2, fix it
5	OP1	Option byte 1	218	(11011010)
	OP2	Option byte 2	33	(00100001)
	OP3	Option byte 3	123	(01111011)
	OP4	Option byte 4	251	(11111011)
	OP5	Option byte 5	63	(00111111)
6	INT	Initial E <sup>2</sup> PROM	According to actual need initial EEPROM	
7	LOGO	Logo	According to actual need set the logo.	
8	STS	Status		
9	AGIN	Aging(escape by local Menu)	Press Menu button on the set to exit.	
0	VG2	Adjust VG2	'In High'/'Out Low' or line disappear	
<p>Note1: the letter in bold and italic is fixed setting.</p> <p>Note2: use blank EEPROM, after turning on the set for the first time, please first initial EEPROM (at INT item press VOL+ button), and reset other factory menu item.</p>				

## Addendix2 Option byte 1-5 meaning

Bit	Option 1	Option 2	Option 3	Option 4	Option 5
7	<b>OSD<sup>1)</sup></b>	<b>FSL<sup>2)</sup></b>	<b>Sound M</b>	<b>DFL</b>	Reserved
	<i>I</i> -enable	<i>0</i> -disable	0- disable	<i>I</i> - disable	
6	Reserved	<b>Function<sup>3)</sup></b> 01-SVM	<b>Sound I</b>	<b>OSD syn.</b>	Reserved
	<i>I</i>		1-enable	1- <i>stable</i>	
5	<b>DVD</b>	10-BBE	<b>Sound BG</b>	<b>PSNS</b>	<b>Italian</b>
	0- RGB, 1-DVD	11-SRS 00-none	1-enable	<i>I</i> -more <sup>4)</sup>	1-enable
4	<b>SVHS</b>	<b>Teletext</b> 000-Pan Euro	<b>Sound DK</b>	<b>HCO</b>	<b>French</b>
	1-enable		1-enable	<i>I</i> -TDA9363	1-enable
3	<b>AV2</b>	001-Ukrainian	<b>Secam-SVM</b>	<b>LOGO</b>	<b>German</b>
	1-enable	010-Russian	1-enable	1-enable	1-enable
2	Super woofer	011-Farsi	<b>Off-RBL</b>	<b>AKB</b>	<b>Arabic</b>
	<i>0</i> -disable	100-Arabic	<i>0</i> -enable	<i>0</i> -on	1-enable
1	<b>Comb filter</b>	<b>Auto sound</b>	<b>EEPROM</b>	<b>Switch on</b>	<b>Spanish</b>
	1-enable	1- disable	1-8k, 250prg	<i>I</i> -Memory Stb 0-Power on Stb	1-enable
0	<b>VG2 mode</b>	<b>AVL</b>	<b>AFC Store</b>	<b>FMWS</b>	<b>English</b>
	<i>0</i> -normal mode	1-enable	<i>I</i> -enable	<i>I</i> - large <sup>5)</sup>	1-enable

Note1: the letter in bold and capital is fixed setting.

Note2: for model without NICAM, please set AVL=0.

Note3: for sound filter in absorbing type in main board (for example K3959D), please set AUTO SOUND=0.

1)*OSO* Switch Off in vertical Over Scan

2)*FSL* Forced Slicing Level

3)*Function* SVM is disable when in RGB,DVD,TEXT or SECAM mode

4)*PSNS* More PAL color sensitivity for Asian market areas

5)*FMWS* Active when M system

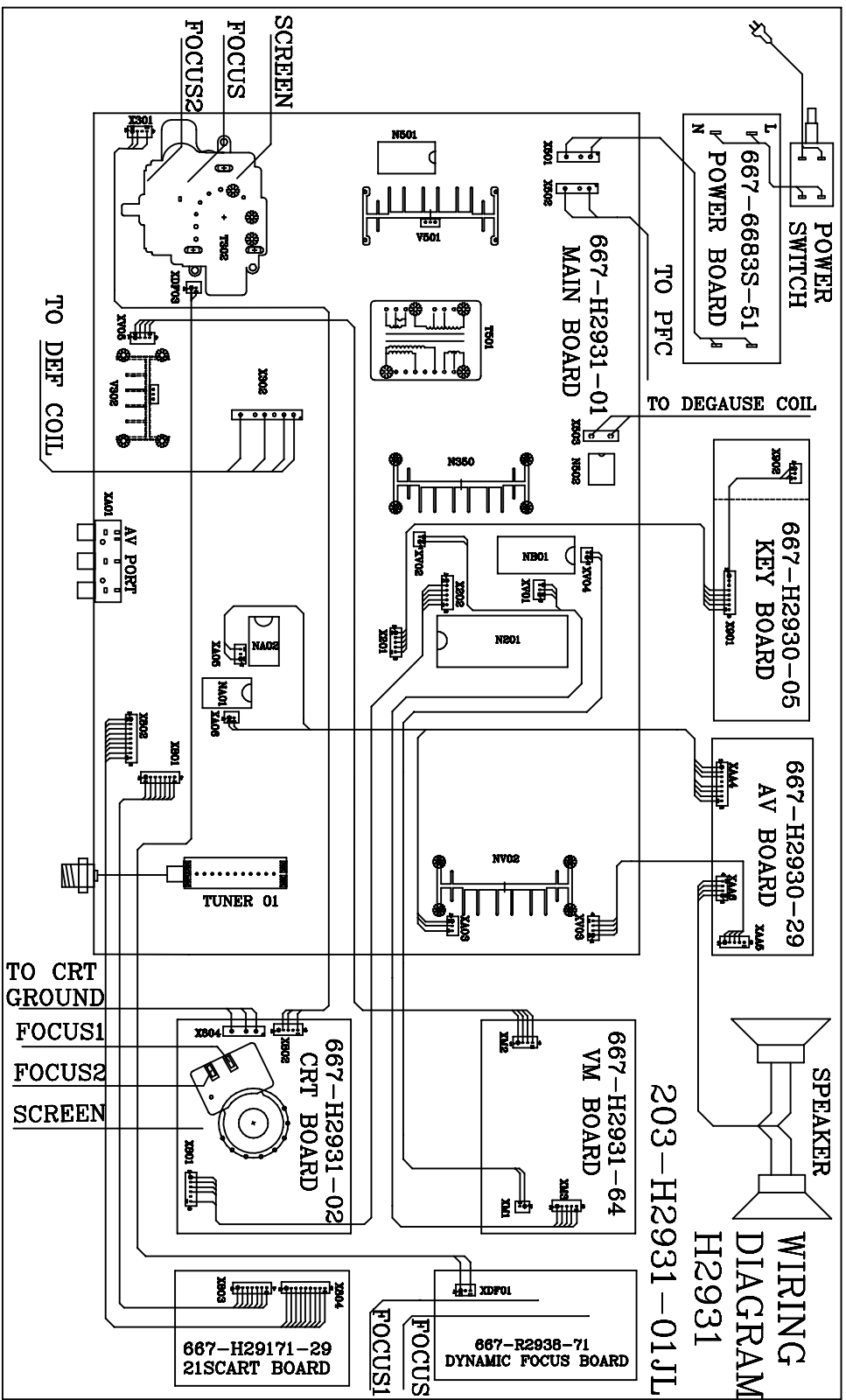

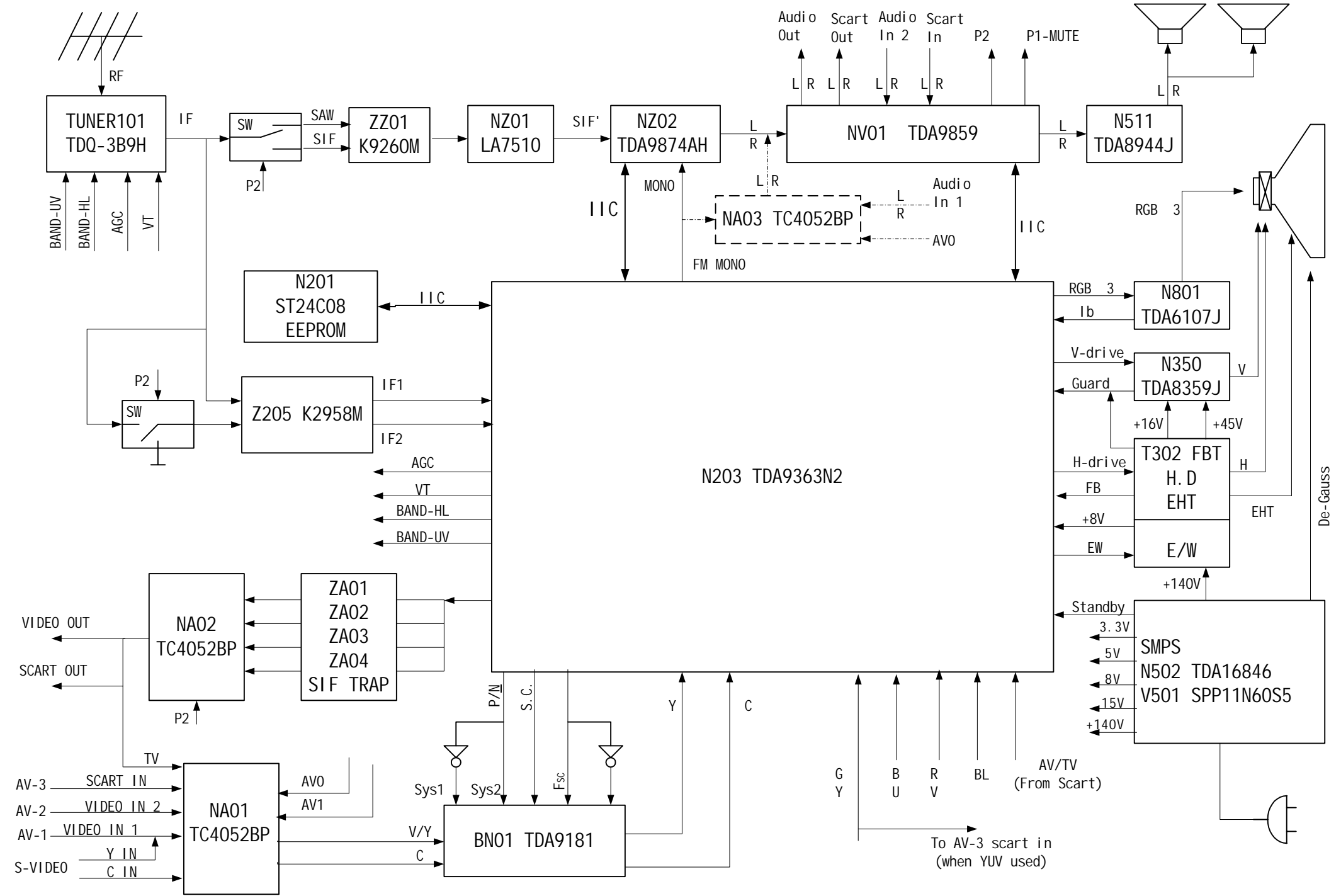

Integrated multistandard comb filter

TDA9181

BLOCK DIAGRAM

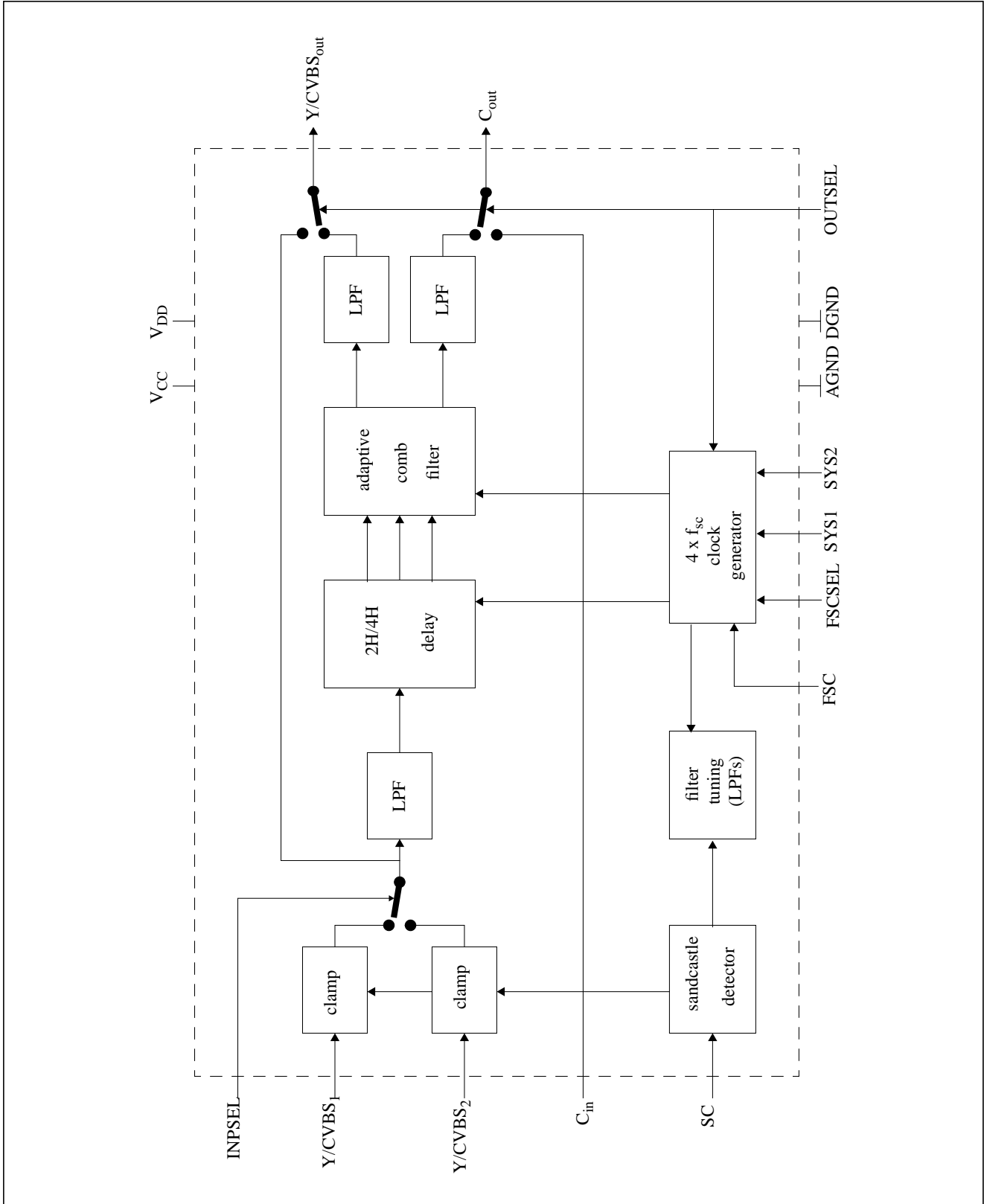

Universal hi-fi audio processor for TV

TDA9859

BLOCK DIAGRAM

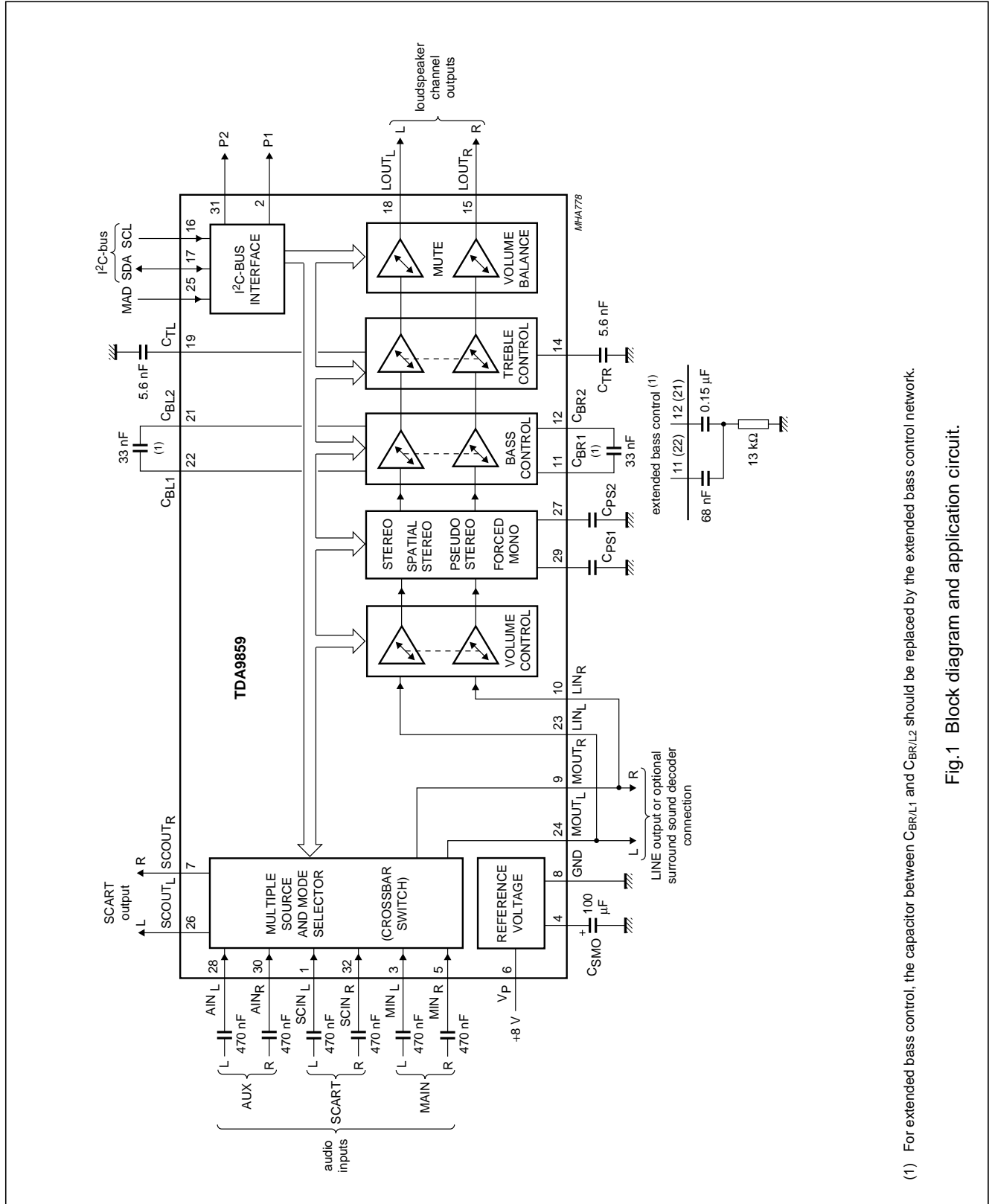

(1) For extended bass control, the capacitor between CBR/L1 and CBR/L2 should be replaced by the extended bass control network.

Fig.1 Block diagram and application circuit.

Digital TV sound demodulator/decoder

TDA9874A

4 BLOCK DIAGRAM

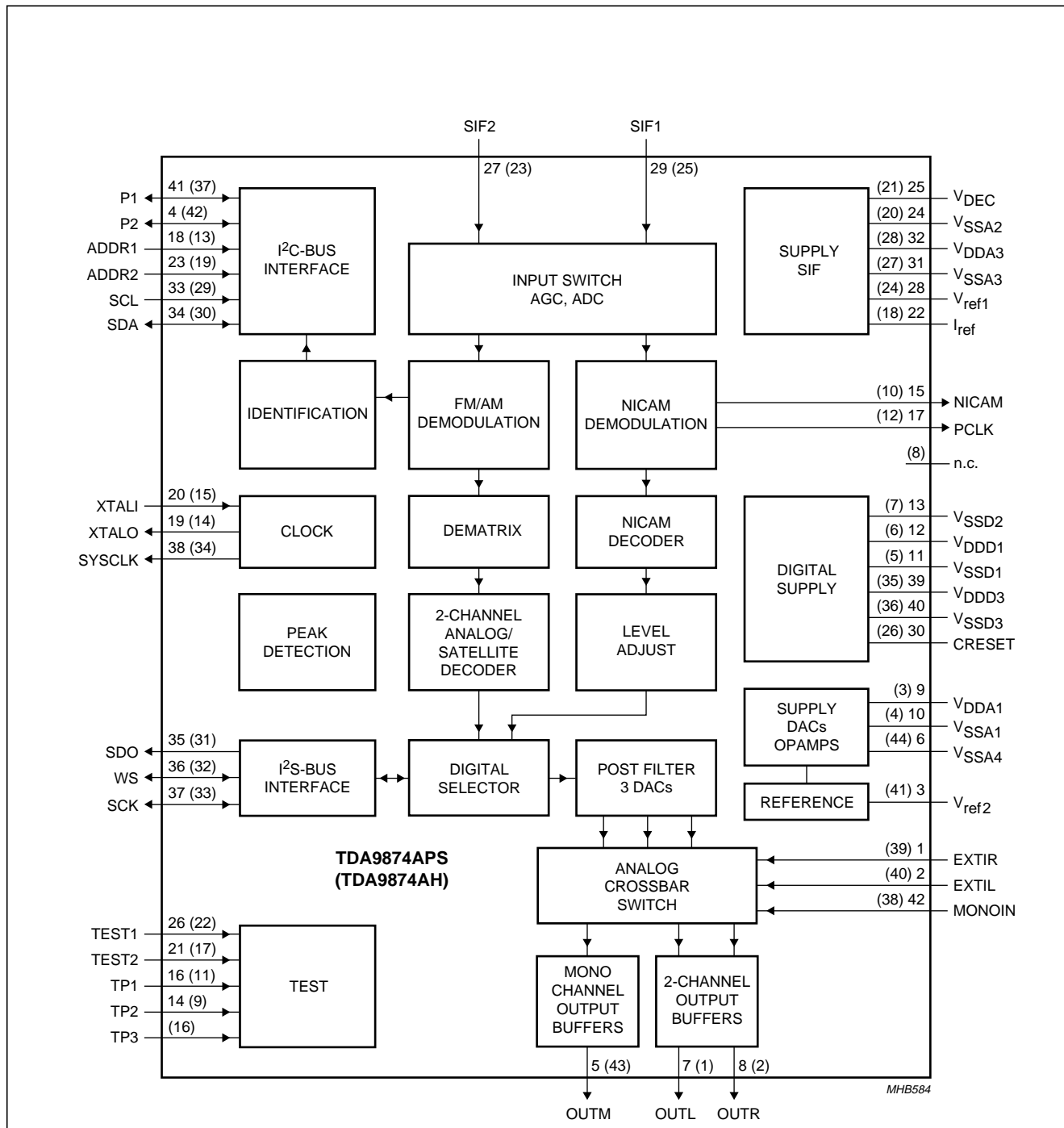

The pin numbers given in parenthesis refer to the TDA9874AH.

Fig.1 Block diagram.

# TV signal processor-Teletext decoder with embedded $\mu$ -Controller

## TDA935X/6X/8X PS/N1 series

### BLOCK DIAGRAM

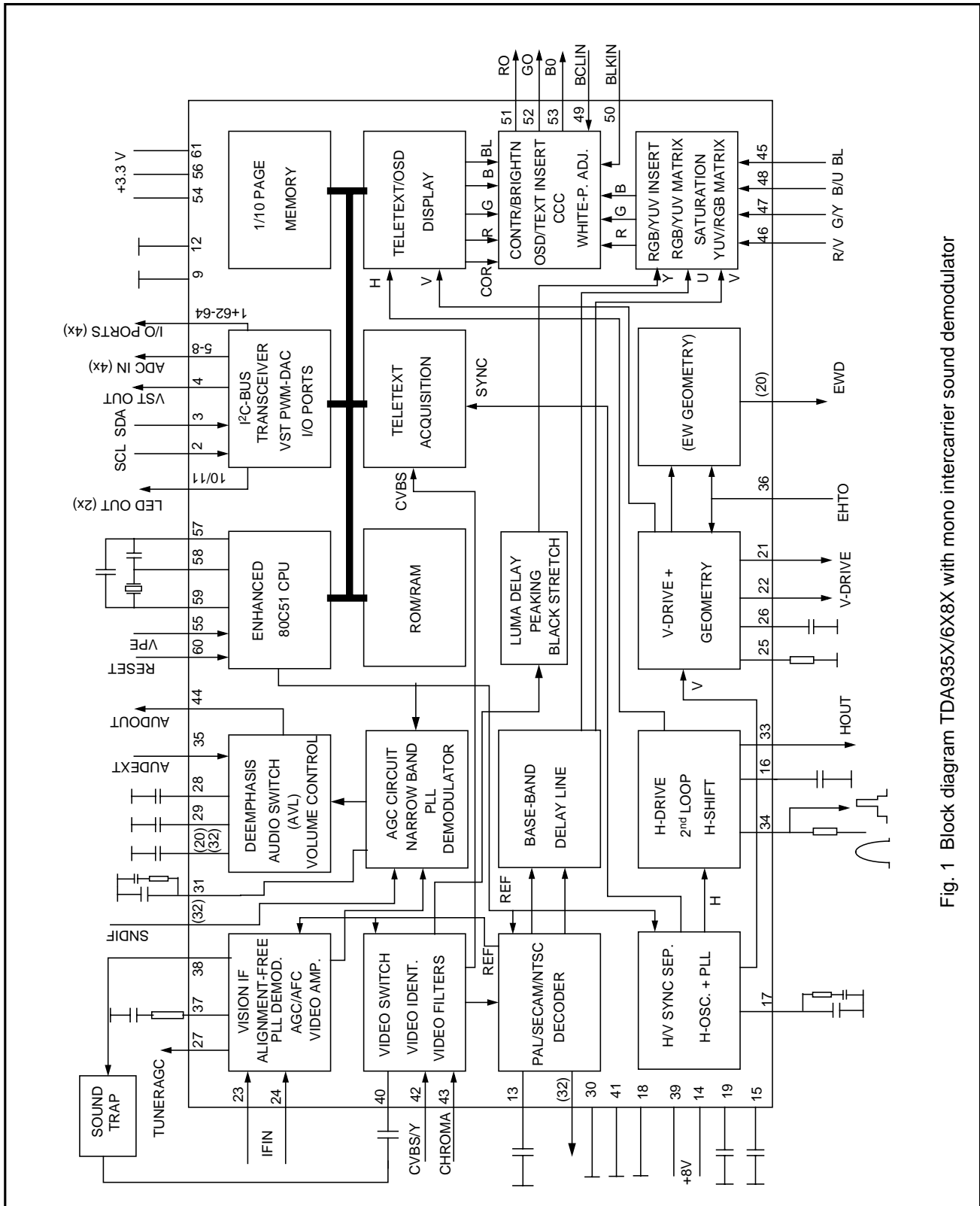
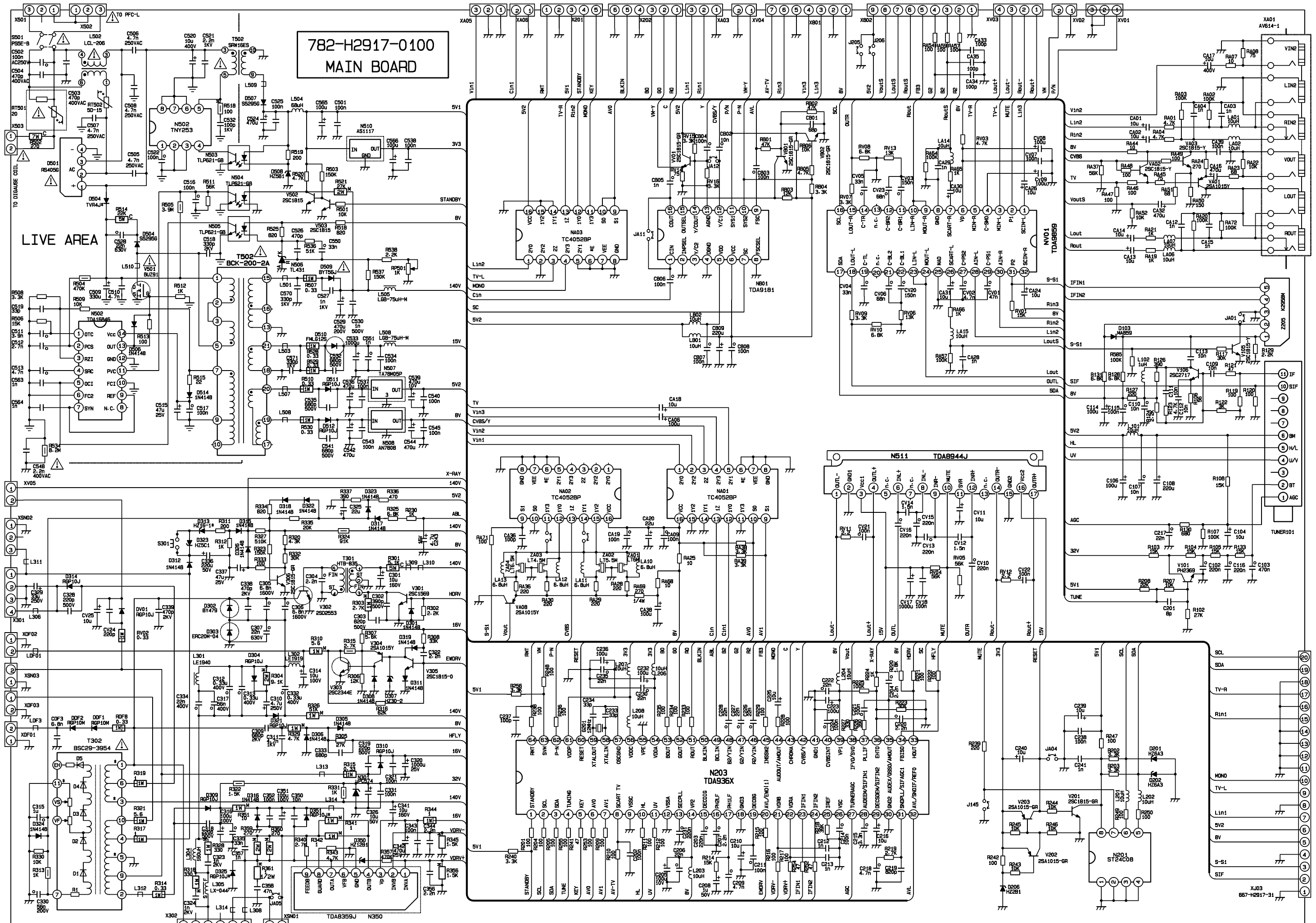
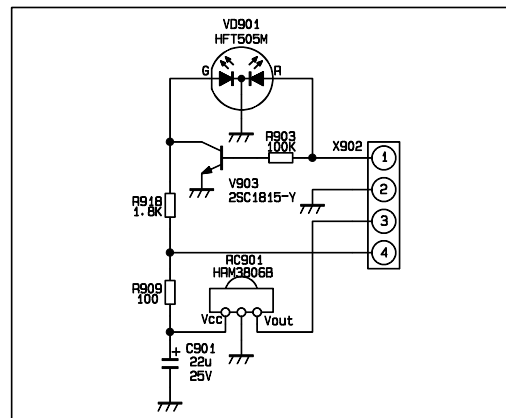
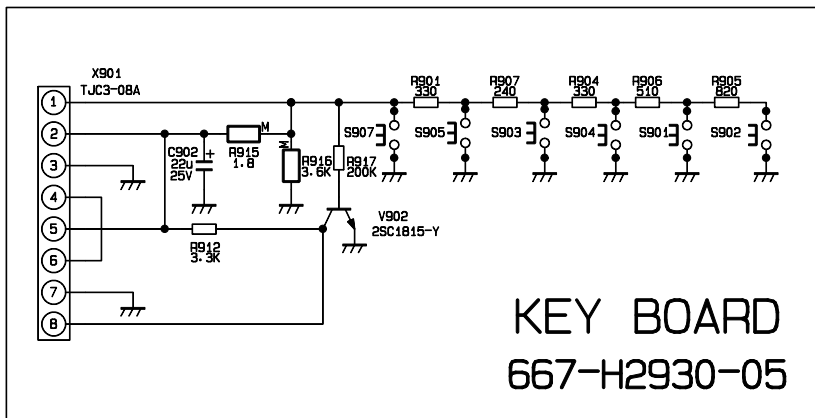
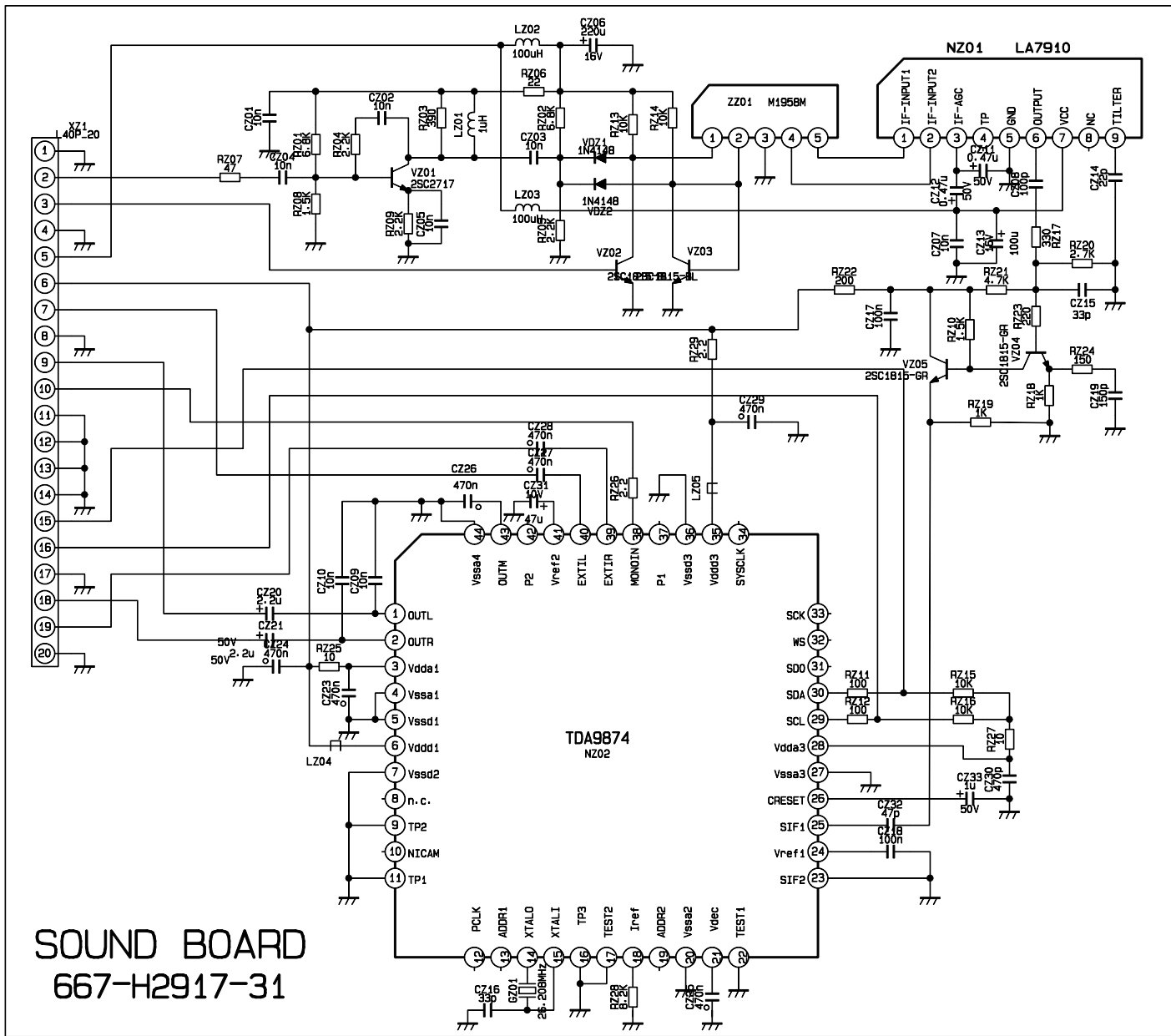

Fig. 1 Block diagram TDA935X/6X8X with mono intercarrier sound demodulator





X.103  
667-H2917-31



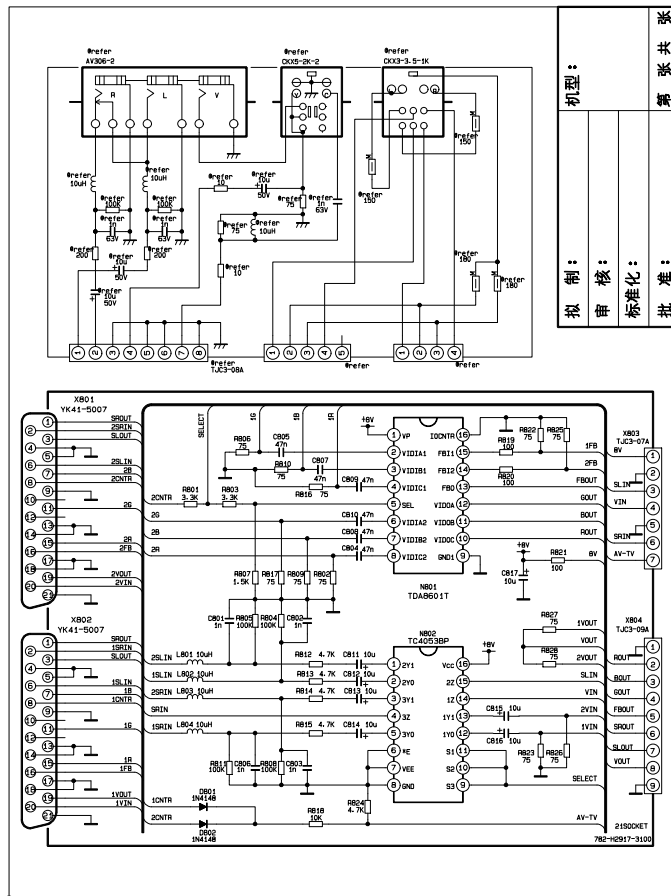

制型:	
拟制:	
审核:	
标准化:	
批准:	

第 张 共 张

**WARNING:** BEFORE SERVICING THIS CHASSIS, READ THE “X-RAY RADIATION PERCAUTION”, “SAFETY PRECAUTION” AND “PRODUCT SAFETY NOTICE” ON PAGE 1&2 OF THIS MANUAL.

**CAUTION:** 1. The shaded areas makes in the schematic diagram and the parts list designate components which have special characteristics important for safety and should be replaced only with type identical to those in the original circuit or specified in the parts list. Before replacing any of these components, read carefully the PRODUCT SAFETY NOTICE on page 2.

2. Do not degrade the safety of the receiver through improper servicing.

## ELECTRICAL PARTS LIST

### MAIN BOARD

SYMBOL	PART NO.	DESCRIPTION
	782-H2917-0100	MAIN PCB
<b>CRYSTAL</b>		
G201	329-61203-00	JA117 12M
<b>RECTIFIER</b>		
D501	340-80015-00	RS405G
D510	340-80012-00	FMLG12S
<b>REGULATED DIODE</b>		
D206	340-50200-003	HZ2B1
D508	340-50410-003	HZ4C1
D320	340-50520-003	HZ5C3
D201	340-50550-003	HZ6A3
D202	340-50550-003	HZ6A3
D350	340-51260-003	HZ12B1
D313	340-51560-003	HZ16-1
D307	340-52990-003	HZ30-2
<b>TRANSISTOR</b>		
V501	343-00600-50	SPP11N60S5
V301	343-15690-00	2SC1569
V302	343-25530-00	2SD2553
V303	343-52480-30	2SC5248E
VV01	343-18150-704	2SC1815-GR
V202	343-10150-104	2SA1015Y Pr2.5
V203	343-10150-104	2SA1015Y Pr2.5
V304	343-10150-104	2SA1015Y Pr2.5
VA01	343-10150-104	2SA1015Y Pr2.5
VA08	343-10150-104	2SA1015Y Pr2.5

<b>SYMBOL</b>	<b>PART NO.</b>	<b>DESCRIPTION</b>
V502	343-18150-104	2SC1815-Y
VA02	343-18150-104	2SC1815-Y
VA03	343-18150-104	2SC1815-Y
VB01	343-18150-104	2SC1815-Y
VB02	343-18150-104	2SC1815-Y
VV02	343-18150-104	2SC1815-Y
VV03	343-18150-104	2SC1815-Y
V503	343-18150-104	2SC1815-Y
V201	343-18150-704	2SC1815-GR
V305	343-18150-704	2SC1815-GR
V306	343-18150-704	2SC1815-GR
V101	343-23690-004	PH2369
V106	343-27170-004	2SC2717
<b>SAW FILTER</b>		
Z201	458-05022-00	K3959D
<b>METAL RESISTOR</b>		
R355	467-2D215-G03	1/4W-1.5K-G
R356	467-2D215-G03	1/4W-1.5K-G
R518	467-2E110-H0	1/2W-100Ω-JL
R310	467-2FA22-H0	1W-2.2Ω-JL
R361	467-2F001-H0	1W-1Ω-JL
R351	467-2F010-H0	1W-10Ω-JL
R318	467-2F133-H0	1W-330Ω-JL
R328	467-2F133-H0	1W-330Ω-JL
R303	467-2F227-H0	1W-2.7KΩ-JL
R329	467-2F247-H0	1W-4.7K-JL
R326	467-2F351-H0	1W-51kΩ-JL
R516	467-2G022-H0	2W-22Ω-JL
R360	467-2G127-H0	2W-270Ω-JL
R304	467-2G318-H0	2W-18kΩ-JL
<b>INDUCTANCE WITH COLOUR CODES</b>		
LB02	471-2010K-003	SPT0305-100K-5
L101	471-2010K-003	SPT0305-100K-5
L203	471-2010K-003	SPT0305-100K-5
L204	471-2010K-003	SPT0305-100K-5
L206	471-2010K-003	SPT0305-100K-5
L207	471-2010K-003	SPT0305-100K-5
LA14	471-2010K-003	SPT0305-100K-5
LA15	471-2010K-003	SPT0305-100K-5
LB01	471-2010K-003	SPT0305-100K-5
L504	471-2068K-103	LGA0410-68uH-K
LA02	471-1010K-00	EL0606SKI-100K

SYMBOL	PART NO.	DESCRIPTION
L201	471-1010K-00	EL0606SKI-100K
L202	471-1010K-00	EL0606SKI-100K
LA07	471-1010K-00	EL0606SKI-100K
LA01	471-1010K-00	EL0606SKI-100K
LA06	471-1010K-00	EL0606SKI-100K
LA10	471-2A68K-A0	SP0203-6.8uH-K
LA12	471-2A68K-A0	SP0203-6.8uH-K
L102	471-2001K-A0	SP0203-1uH-K
L208	471-2010K-00	SPT0305-100K-5
<b>MELTABLE RESISTOR</b>		
RV02	467-4FA56-H0	1W-5.6Ω-JL
R317	467-4FB33-H0	1W-0.33Ω-JL
R321	467-4FA27-H0	1W-2.7Ω-JL
R314	467-4FB33-H0	1W-0.33Ω-JL
R315	467-4FB33-H0	1W-0.33Ω-JL
R528	467-4FB33-H0	1W-0.33Ω-JL
R529	467-4FB33-H0	1W-0.33Ω-JL
R530	467-4FB68-H0	1W-0.68Ω-JL
R319	467-4F001-H0	1W-1Ω-JL
R354	467-4F001-H0	1W-1Ω-JL
R510	467-4GA22-H0	2W-2.2Ω-JL
R507	467-4GB27-H0	2W-0.27Ω-JL
R317	467-4FA15-H0	1W-1.5Ω-JL
RV02	467-4FA56-H0	1W-5.6Ω-JL
R317	467-4FB33-H0	1W-0.33Ω-JL
<b>IC</b>		
N510	*352-11170-70	GS1117CT-3.3
N502	352-02540-40	TNY254P
N506	352-04310-00	LM431A
N301	352-05740-00	uPC574
N503	352-06210-60	TLP621-GB
N504	352-06210-60	TLP621-GB
N505	352-06210-60	TLP621-GB
N501	352-16846-00	TDA16846
N202	352-24080-50	M24C08BN6
NA01	352-40520-60	TC4052BP
N507	352-78050-00	KA7805
N508	352-78080-00	AN7808
N350	352-83590-90	TDA8359J/N2
NV02	352-89440-70	TDA8944J
NB01	352-91810-00	*TDA9181P
N201	352-93630-00	*TDA9363PS/N2/5I

SYMBOL	PART NO.	DESCRIPTION
NV01	352-98590-00	TDA9859
<b>CERAMIC CAPACITOR</b>		
C503	459-B147M-20	ECK-DNS471MBX !
C504	459-B147M-20	ECK-DNS471MBX !
C548	459-B222M-20	ECK-DNS222MEX !
C505	459-B247R-00	DE0807F472ZAC250V !
C506	459-B247R-00	DE0807F472ZAC250V !
C507	459-B247R-00	DE0807F472ZAC250V !
C508	459-B247R-00	DE0807F472ZAC250V !
<b>FIXED INDUCTANCE</b>		
L302	477-40020-00	LE1919
L506	477-40028-00	L912
L505	477-40057-00	LG101
L304	477-40107-00	160uH
	477-40205-00	* LEY-433-1T
<b>FBT</b>		
T302	472-27130-00	BSC29-3991N !
<b>POWER TRANSFORMER</b>		
T502	470-00191-00	SRW16ES-X03V112 !
<b>SWITCH TRANSFORMER</b>		
T501	470-00269-00	BCK200-1D !
<b>CERAMIC TRAP FILTER</b>		
ZA02	475-25551-00	XT5.5MB
ZA01	475-25601-00	XT6.0MB
ZA04	475-25651-00	XT6.5MB
<b>POWER FILTER</b>		
L502	477-20047-00	LCL-205
<b>H-LINEARITY INDUCTANCE</b>		
L305	477-00057-00	HL1835H-X10
<b>H-DRIVE TRANSFORMER</b>		
T301	472-10027-00	HTB-835
<b>CEMENT RESISTOR</b>		
R301	467-50251-H8	RJG27-3C-5W-5.1K-J
R514	467-50322-H8	RJG27-3C-5W-22K-J
R502	467-51127-H4	RX27-3H-7W-270Ω-J
<b>VITREOUS-ENAMEL RESISTOR</b>		
R504	467-7F447-H0D	RI40-1W-470K-JL
<b>WIRE-ROUND RESISTOR</b>		
R352	467-6FA15-H0	RX21-1-1.5Ω-J
R353	467-6FA15-H0	RX21-1-1.5Ω-J
<b>CARBON RESISTOR</b>		
R505	467-8E539-K0	1/2W-3.9MΩ-KL !

SYMBOL	PART NO.	DESCRIPTION
R534	467-8E582-H0A	1/2W-8.2MΩ-J !
<b>THERMISTOR</b>		
RT501	469-10007-00	PTH451C262BG200N270
RT502	469-40004-00	5D2-14LC
<b>OTHER</b>		
DEGAUSSING COIL	477-12801-00	BD-205-3 !
POWER SWITCH	360-30028-00	KDC-A04-S !
POWER CORD	493-75710-07	VDE !
CRT	335-2932H-00	A68QCP891X001 !
TUNER101	590-30533-00	TDQ-3B9H/124XS !

### NICAM BOARD

SYMBOL	PART NO.	DESCRIPTION
	782-H2917-3100	NICAM PCB
<b>CRYSTAL</b>		
GZ01	329-62404-00	HC-49/US 24.576MHZ
<b>TRANSISTOR</b>		
VZ04	343-18150-60	2SC1815-0
VZ05	343-18150-60	2SC1815-0
VZ01	343-27170-00	2SC2717
<b>IC</b>		
NZ01	352-75100-00	LA7510
NZ02	*352-98740-10	TDA9874AH
<b>SAW FILTER</b>		
ZZ01	458-05023-00	K9260M
<b>INDUCTANCE WITH COLOUR CODES</b>		
LZ02	471-1110H-00	EL0606SKI-101J
LZ03	471-1110H-00	EL0606SKI-101J
LZ01	471-2001K-00	SPT0305-1R0K-5

### BUTTON BOARD

SYMBOL	PART NO.	DESCRIPTION
	782-H2930-0500	BUTTON PCB
<b>TRANSISTOR</b>		
V902	343-18150-10	2SC1815-Y
V903	343-18150-10	2SC1815-Y
<b>LIGHT-EMITTING DIODE</b>		
VD901	340-10055-90	HFT505M
<b>METAL RESISTOR</b>		
R915	467-2D218-G0	1/4W-1.8K-G
R916	467-2D236-G0	1/4W-3.6K-G



SYMBOL	PART NO.	DESCRIPTION
<b>IC</b>		
RC901	352-03810-80	AT138B-T12 (M)

### SIDE AV BOARD

SYMBOL	PART NO.	DESCRIPTION
	782-H2930-2900	SIDE AV PCB
<b>METAL RESISTOR</b>		
RAA9	467-2E115-H0	1/2W-150Ω-JL
RAA10	467-2E115-H0	1/2W-150Ω-JL
RAA11	467-2E118-H0	1/2W-180Ω-JL
RAA12	467-2E118-H0	1/2W-180Ω-JL
<b>INDUCTANCE WITH COLOUR CODES</b>		
LAA1	471-2010K-A0	SP0203-10uH-K
LAA2	471-2010K-A0	SP0203-10uH-K
LAA3	471-2010K-A0	SP0203-10uH-K

### CRT BOARD

SYMBOL	PART NO.	DESCRIPTION
	782-R2990-020A	CRT PCB
<b>DIODE</b>		
VD801	340-00010-00	S5295G
VD802	340-00010-00	S5295G
VD803	340-00010-00	S5295G
<b>IC</b>		
N801	352-61070-70	TDA6107JF (M)
<b>CRT SOCKET</b>		
X803	364-58220-00	GZS10-301D !
<b>METAL RESISTOR</b>		
R809	467-2G110-H0	2W-100Ω-JL
<b>MELTABLE RESISTOR</b>		
R810	467-4GA22-H0	2W-2.2Ω-JL
<b>CARBON RESISTOR</b>		
R804	467-8E227-H0A	1/2W-2.7KΩ-J !
R805	467-8E227-H0A	1/2W-2.7KΩ-J !
R806	467-8E227-H0A	1/2W-2.7KΩ-J !
<b>METAL RESISTOR</b>		
R801	467-2E110-H0	1/2W-100Ω-JL
R802	467-2E110-H0	1/2W-100Ω-JL
R803	467-2E110-H0	1/2W-100Ω-JL

## VM BOARD

SYMBOL	PART NO.	DESCRIPTION
	782-29FA0-6400	VM PCB
<b>DIODE</b>		
VD611	340-00001-00	1N4148
VD606	340-00001-00	1N4148
VD604	340-00001-00	1N4148
VD603	340-00001-00	1N4148
VD607	340-00001-00	1N4148
VD608	340-00001-00	1N4148
VD610	340-00079-00	FR103
VD609	340-00079-00	FR103
<b>TRANSISTOR</b>		
V603	343-07520-10	2SC752GTM-Y
V607	343-07520-10	2SC752GTM-Y
V610	343-10150-11	2SA1015Y
V602	343-10150-11	2SA1015Y
V615	343-12060-00	RN1206
V614	343-12060-00	RN1206
V613	343-12060-00	RN1206
V604	343-18150-11	2SC1815-Y
V605	343-18150-11	2SC1815-Y
V606	343-18150-11	2SC1815-Y
V609	343-18150-11	2SC1815-Y
V619	343-18150-11	2SC1815-Y
V620	343-18150-11	2SC1815-Y
V601	343-18150-11	2SC1815-Y
V611	343-19640-30	2SA1964E
V612	343-52480-30	2SC5248E
<b>METAL RESISTOR</b>		
R640	467-2EA27-G0	1/2W-2.7Ω-GL
R639	467-2EA27-G0	1/2W-2.7Ω-GL
R630	467-2E010-H0	1/2W-10Ω-JL
R638	467-2E033-H0	1/2W-33Ω-JL
R642	467-2E033-H0	1/2W-33Ω-JL
R644	467-2E068-H0	1/2W-68Ω-JL
R628	467-2E133-H0	1/2W-330Ω-JL
R619	467-2E147-H0	1/2W-470Ω-JL
R643	467-2F115-H0	1W-150Ω-JL
<b>INDUCTANCE WITH COLOUR CODES</b>		
L601	471-2047K-A0	SP0203-47uH-K

SYMBOL	PART NO.	DESCRIPTION
<b>CERAMIC TRAP FILTER</b>		
Z602	475-25361-00	TPS3.58MJ
Z601	475-25441-00	TPS4.43M
<b>BRIGHTNESS DELAY LINE</b>		
DL601	591-10018-00	YBL 48E08

### POWER FILTER BOARD

SYMBOL	PART NO.	DESCRIPTION
	782-66830-511A	POWER FILTER PCB
<b>THIN-FILM CAPACITOR</b>		
	462-2B410-M0V	250VAC-0.1uF-M !
<b>CARBON RESISTOR</b>		
	467-8E522-H0A	1/2W-2.2M-J !
<b>POWER FILTER</b>		
	477-20031-00	LCL-21 !
<b>FUSE</b>		
	569-14141-80	50T 4AL 250V !

### DYNAMIC FOCUS BOARD

	PART NO.	DESCRIPTION
	782-29FA0-711B	DYNAMIC FOCUS PCB
<b>CARBON RESISTOR</b>		
	467-8E227-H1A	1/2W-2.7KΩ-J !
<b>DYNAMIC FOCUS TRANSFORMER</b>		
	472-60001-00	BCT222
<b>ADJUSTABLE INDUCTANCE</b>		
	477-30011-00	TLN2110