

Mat. – Nr. – Konstante
3740

- 1) 06 0083
- 2) 17 2274
- 3) 06 0115

Mat. – Nr. – Konstante
3740

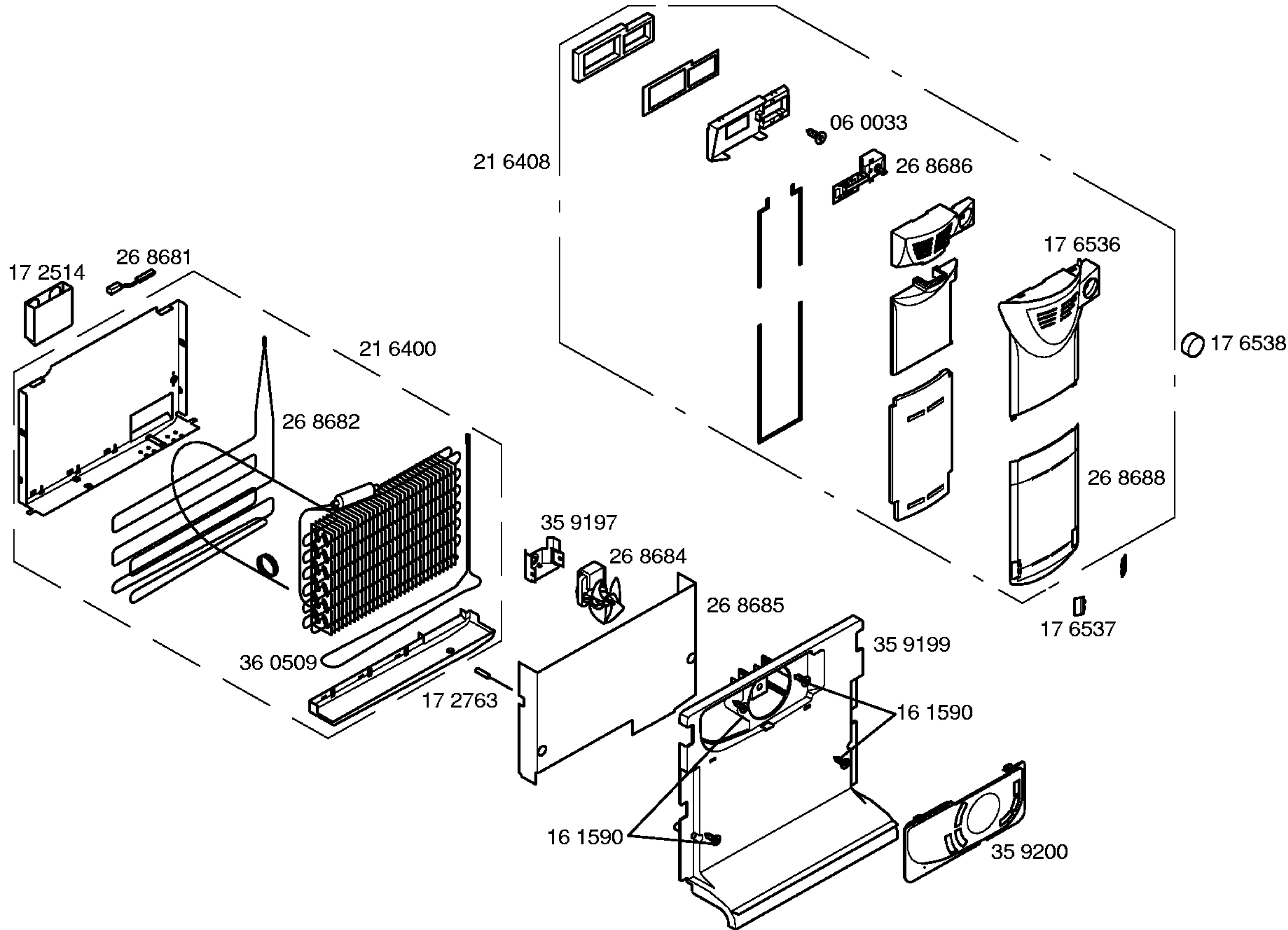

Mat. – Nr. – Konstante
3740

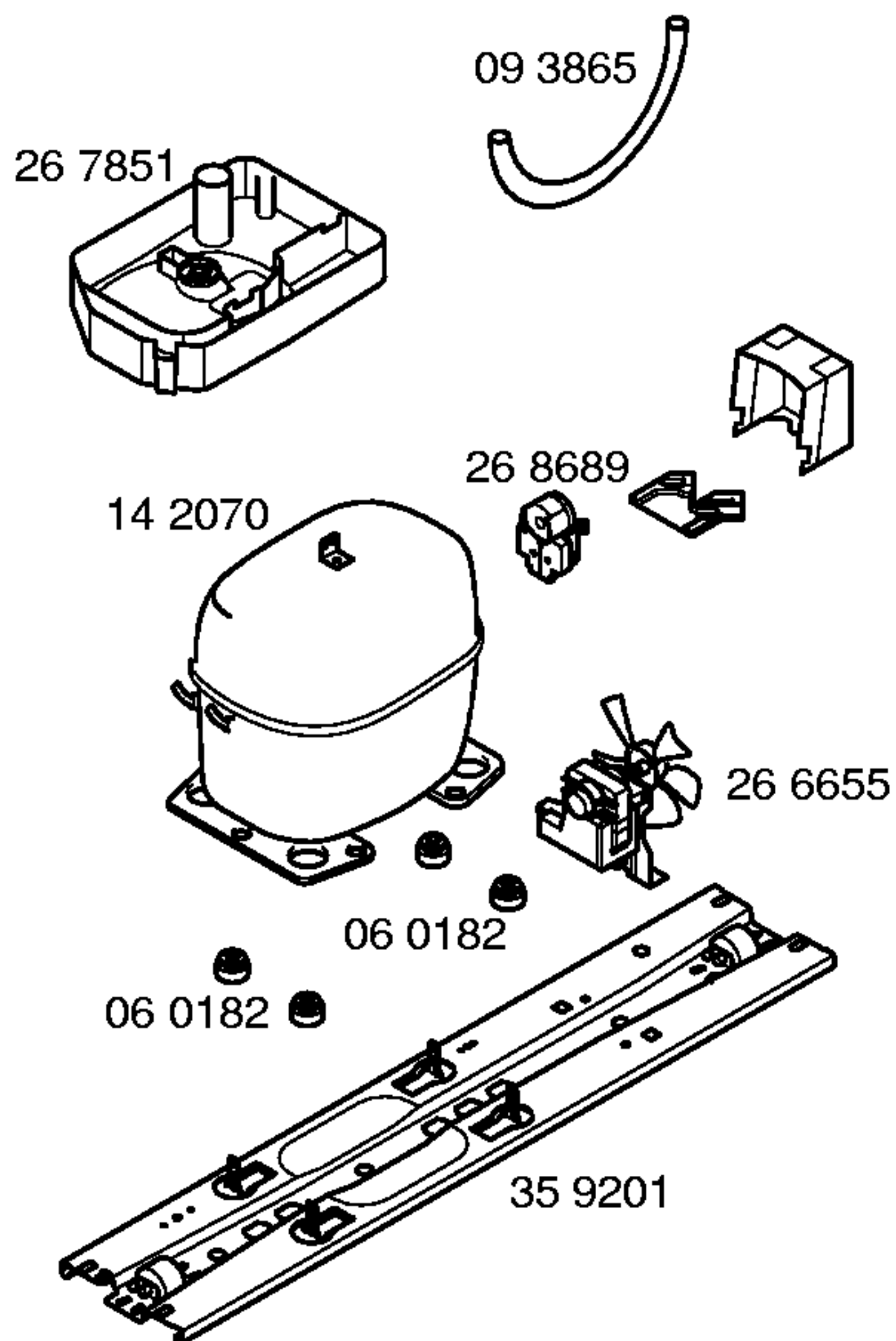

TECHNISCHE DATEN/TECHNICAL DATA/DONNEES TECHNIQUES/DATOS TECNICOS				
Verdichter/Compressor/Compresseur/Compresor Typ/Type/Tipo Förderleistung/Delivery/Debit/Aspiración l/h Anlaufstrom/Starting current/Cour.démarrage/Int.arranque A Widerstand/Resistance/Resistencia. Ha/main/prin. Ohm Hi/aux.	ASPERA NBT 1118Y 2574 – 11.0 16.4			
Klappe Therm./Thermostat/Termostat Typ/Type/Tipo Reglerstellung/Position/Conexión Schaltwerte/Switching values/ ..ein/conex.°C Valeurs de commutation/Desconex. ..aus"/descon. (..abtaven' od) ..alarm'				
Füllmenge/Fill. quantity/Charge/Carga R600	g	45		
Anschlusswert/Comm. load/Puiss. Connect./Potenc.	W	150		
Heizung/Heater/Chauflage/Resistenc.descong. Widerstand/Resistance/Resistencia Leistung/Power/Puissance/Potencia	KΩ W	Verdampfer 0.38 145/230	Ablaufrinne 1.4 37.5/230	Luftkanal 13.49 4/230
Ventilador/Blower/Ventilateur/Ventilador Widerstand/Resistance/Resistencia	KΩ	Verdichter 0.61	Verdampfer 0.41	