

DAEWOO

Service Manual

Split System Air Conditioner

Model: DSB-070LH
DSB-091LH
DSB-121LH
DSB-122LH
DSB-240LH-R

✓ Caution

: In this Manual, some parts can be changed for improving, their performance without notice in the parts list. So, if you need the latest parts information, please refer to PPL(Parts Price List) in Service Information Center (<http://svc.dwe.co.kr>).



DAEWOO ELECTRONICS CO., LTD.



Contents

CONTENTS

1. Specifications	2
2. Outline and Dimensions	6
3. Operation	12
4. Wiring Diagram	28
5. Refrigerant Cycle	32
6. Control Block Diagram	33
7. Electric Circuit Diagram	34
8. Trouble Shooting	36
9. Key Components of Electronic Circuit	62
10. Disassembly Instructions	65
1) Indoor Unit	65
2) Outdoor Unit	68
3) Exploded Diagram (Indoor Unit)	71
4) Exploded Diagram (Outdoor Unit)	79
5) Control Box Assembly	87

1. SPECIFICATIONS

* DSB-070LH

ITEM		MODEL	DSB-070LH	
Function		Cooling & Heating		
Class		T		
Power		AC 220~ 240V/ 50Hz		
Capacity		W	2,051/2,051	
		Btu/h	7,000/7,000	
Dehumidification		l/h	0.89	
Electrical Data	Running Current	A	3/3.2	
	Power Input	W	676/693	
	Starting Current	A	18	
Compressor	Type		Rotary	
	Model		QB 134PL 12B	
	Capacitor		25 μ F/400VAC	
Fan Motor			Indoor Unit	Outdoor Unit
	Type		Cross flow fan	Propeller fan
	Capacitor		1.0 μ F 400VAC	1.8 μ F 400V
	Motor Model Number		IC-8417DWKF5A	IC-9625DWLF5A
Refrigerant (R-22)	Control		Capillary	
	Charge Q'ty	g	900	
Connection	Type		Flare	
	OD (Liquid/Suction)	in(mm)	1/4 (6.35)	1/2 (12.7)
Dimensions (W x H x D)		mm	750 x 245 x 174	654 x 549 x 256
Net Weight		kg	7.0	34

* DSB-091LH

ITEM		MODEL	DSB-091LH	
Function		Cooling & Heating		
Class		T		
Power		AC 220~240V/ 50Hz		
Capacity		W	2,637/2,637	
		Btu/h	9,000/9,000	
Dehumidification		l/h	1.15	
Electrical Data	Running Current	A	4.0/4.2	
	Power Input	W	910/940	
	Starting Current	A	24	
Compressor	Type		Rotary	
	Model		RBB100A001	QK 185PN13B
	Capacitor		30 μ F / 450VAC	35 μ F / 400VAC
Fan Motor			Indoor Unit	Outdoor Unit
	Type		Cross flow fan	Propeller fan
	Capacitor		1.0 μ F 400VAC	1.8 μ F 400V
	Motor Model Number		IC-8417DWKF5A	IC-9630DWLF5A
Refrigerant (R-22)	Control		Capillary	
	Charge Q'ty	g	1,150	
Connection	Type		Flare	
	OD (Liquid/Suction)	in(mm)	1/4 (6.35)	1/2 (12.7)
Dimensions (W x H x D)		mm	750 x 245 x 174	654 x 549 x 256
Net Weight		kg	7.0	34

* DSB-121LH/122LH

ITEM		MODEL	DSB-121LH/122LH	
Function		Cooling & Heating		
Class		T		
Power		AC 220~240V/ 50Hz		
Capacity		W	3,654/3,946	
		Btu/h	12,500/13,500	
Dehumidification		l/h	1.6	
Electrical Data	Running Current	A	7.0/6.5	
	Power Input	W	1,500/1,410	
	Starting Current	A	37	
Compressor	Type		Rotary	
	Model		RCB 150A001	
	Capacitor		35 μ F/ 400VAC	
Fan Motor	Division		Indoor Unit	Outdoor Unit
	Type		Cross flow fan	Propeller fan
	Capacitor		1.0 μ F 400VAC	3.5 μ F 400VAC
	Motor Model Number		IC-8428DWKG7C	IC-9430DWLC5B
Refrigerant (R-22)	Control		Capillary	
	Charge Q'ty	g	1,060	
Connection	Type		Flare	
	OD (Liquid/Suction)	in(mm)	1/4 (6.35)	1/2 (12.7)
Dimensions (W x H x D)		mm	925 x 285 x 194	666 x 552 x 264(Before)
				654 x 549 x 256(After)
Net Weight		kg	9.7	34

* DSB-240LH

ITEM		MODEL	DSB-240LH	
Function		Cooling & Heating		
Class		T		
Power		AC 220~240V/ 50Hz		
Capacity		W	7,030	
		Btu/h	24,000	
Dehumidification		l/h	2.67	
Electrical Data	Running Current	A	13.4 / 13.6	
	Power Input	W	2,450 / 2,500	
Compressor	Type		Recipro	
	Model		AWG5530EXC	
	Capacitor		45μF/ 400VAC	
Fan Motor	Division		Indoor Unit	Outdoor Unit
	Type		Cross flow fan	Propeller fan
	Capacitor		2μF 400VAC	5μF 400VAC
	Motor Model Number		IC9430DWKG7A	05ME986DERC
Refrigerant (R-22)	Control		Capillary	
	Charge Q'ty	g	2,200	
Connection	Type		Flare	
	OD (Liquid/Suction)	in(mm)	3/8 (9.52)	5/8 (15.9)
Dimensions (W x H x D)		mm	1080 x 298 x 200	872 x 675 x 325
Net Weight		kg	14.7	64

2. OUTLINE AND DIMENSIONS

1 INDOOR UNIT

* DSB-070LH/DSB-091LH

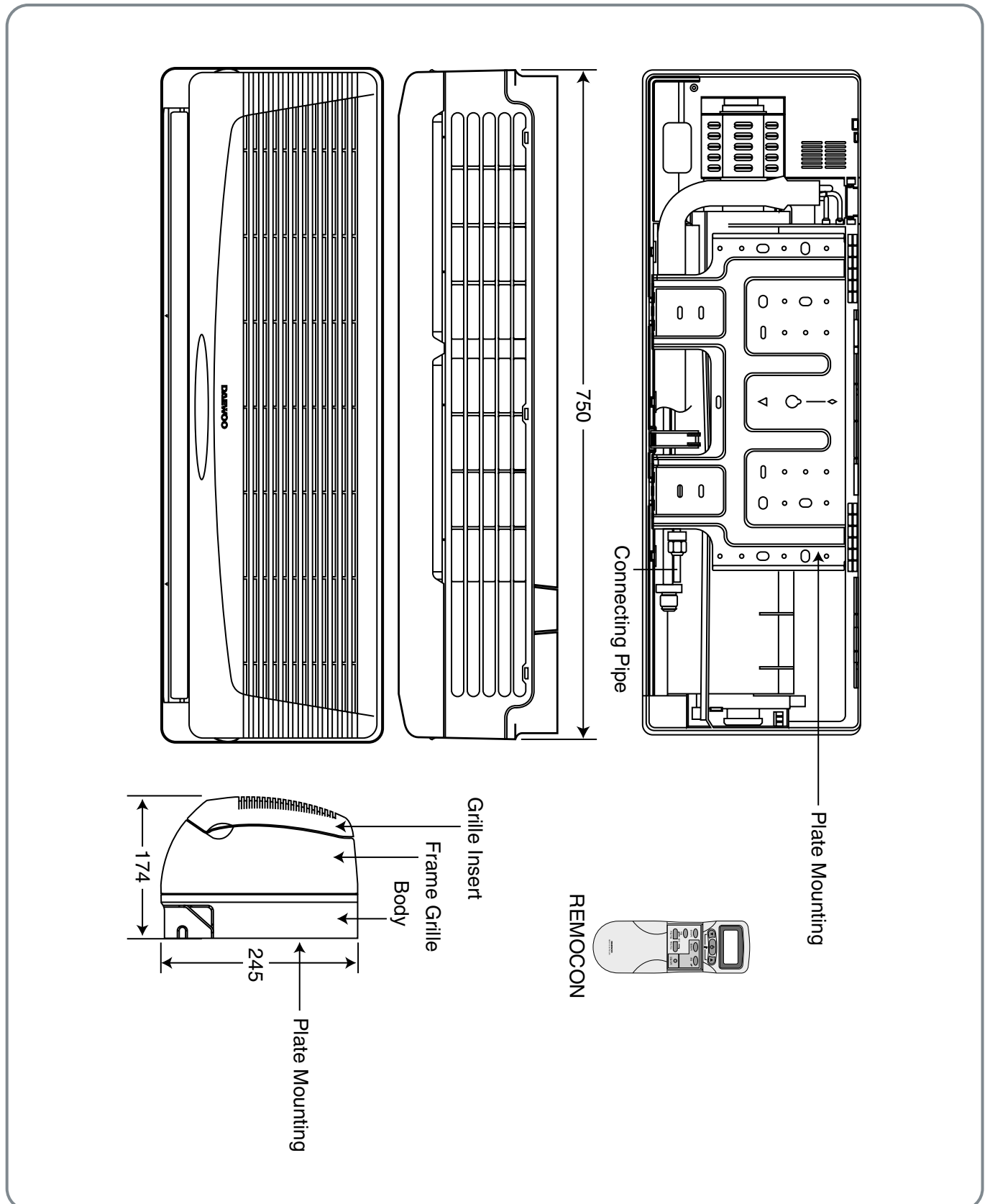

* DSB-121LH/122LH

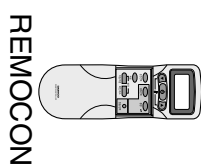
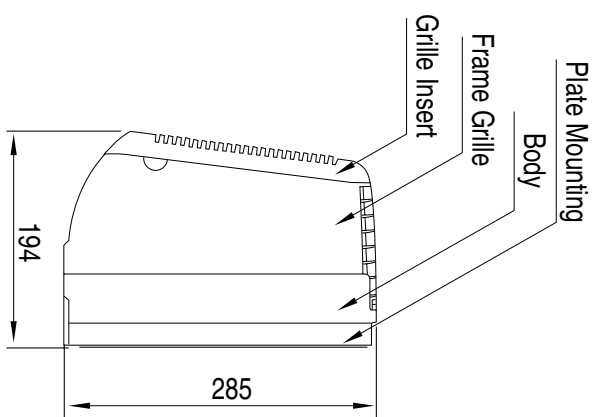
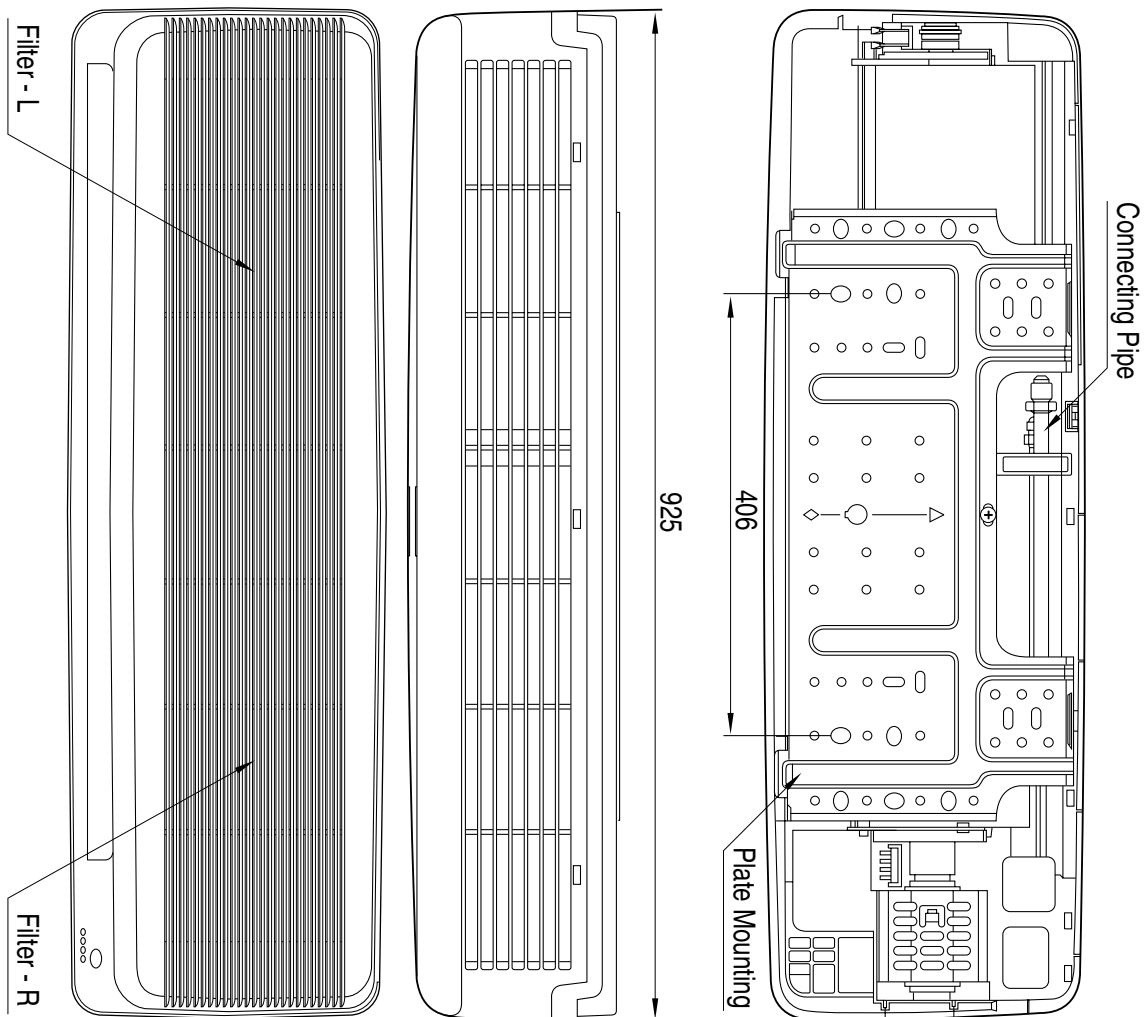

2 OUTDOOR UNIT

* DSB-070LH/DSB-091LH/DSB-121LH/DSB-122LH(After)

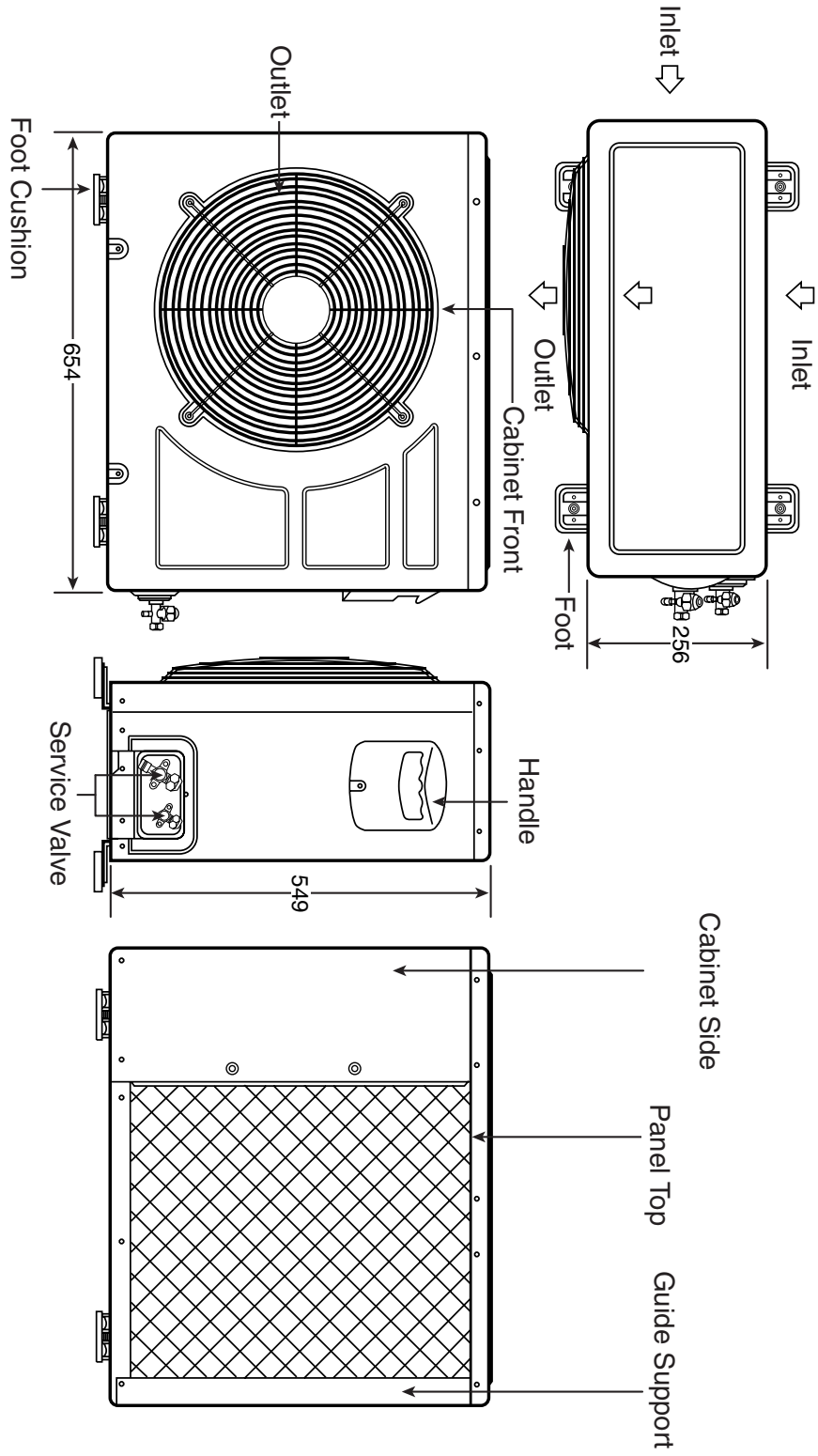

* DSB-121LH/122LH(Before)

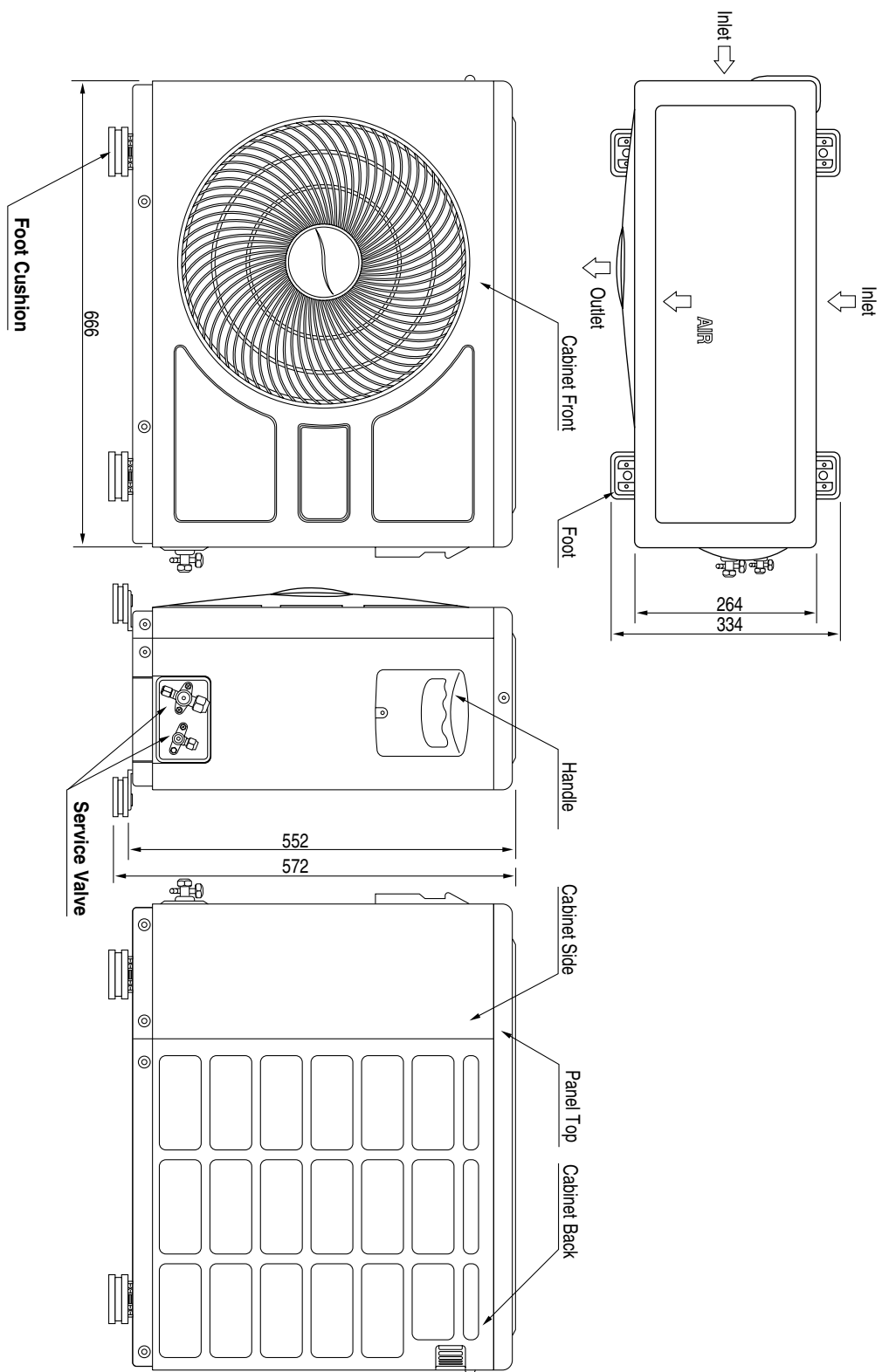

* DSB-240LH

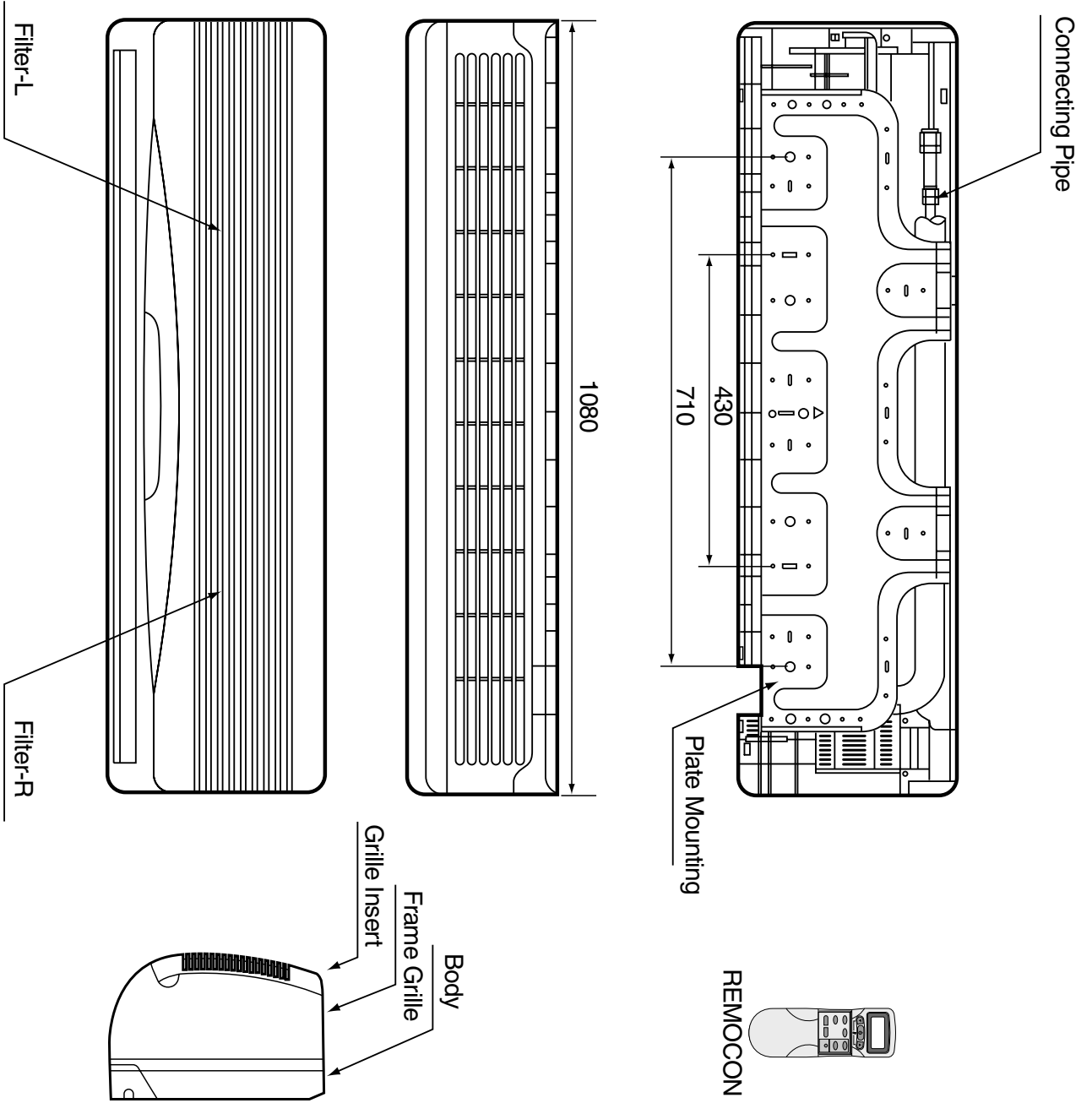

* DSB-240LH

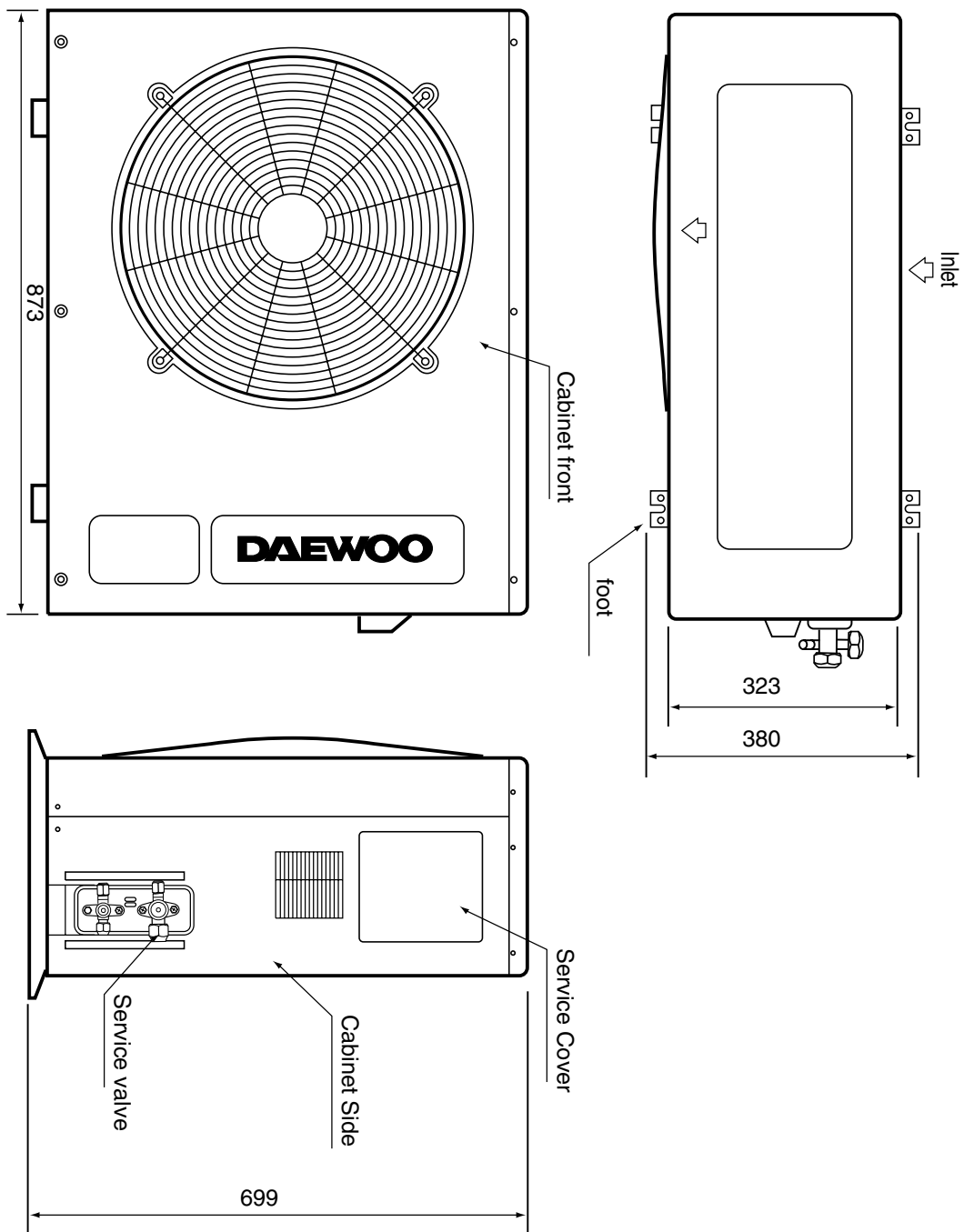

3. OPERATION

1 PARTS OF NAME AND FUNCTION

* DSB-070LH/DSB-091LH

Indoor Unit

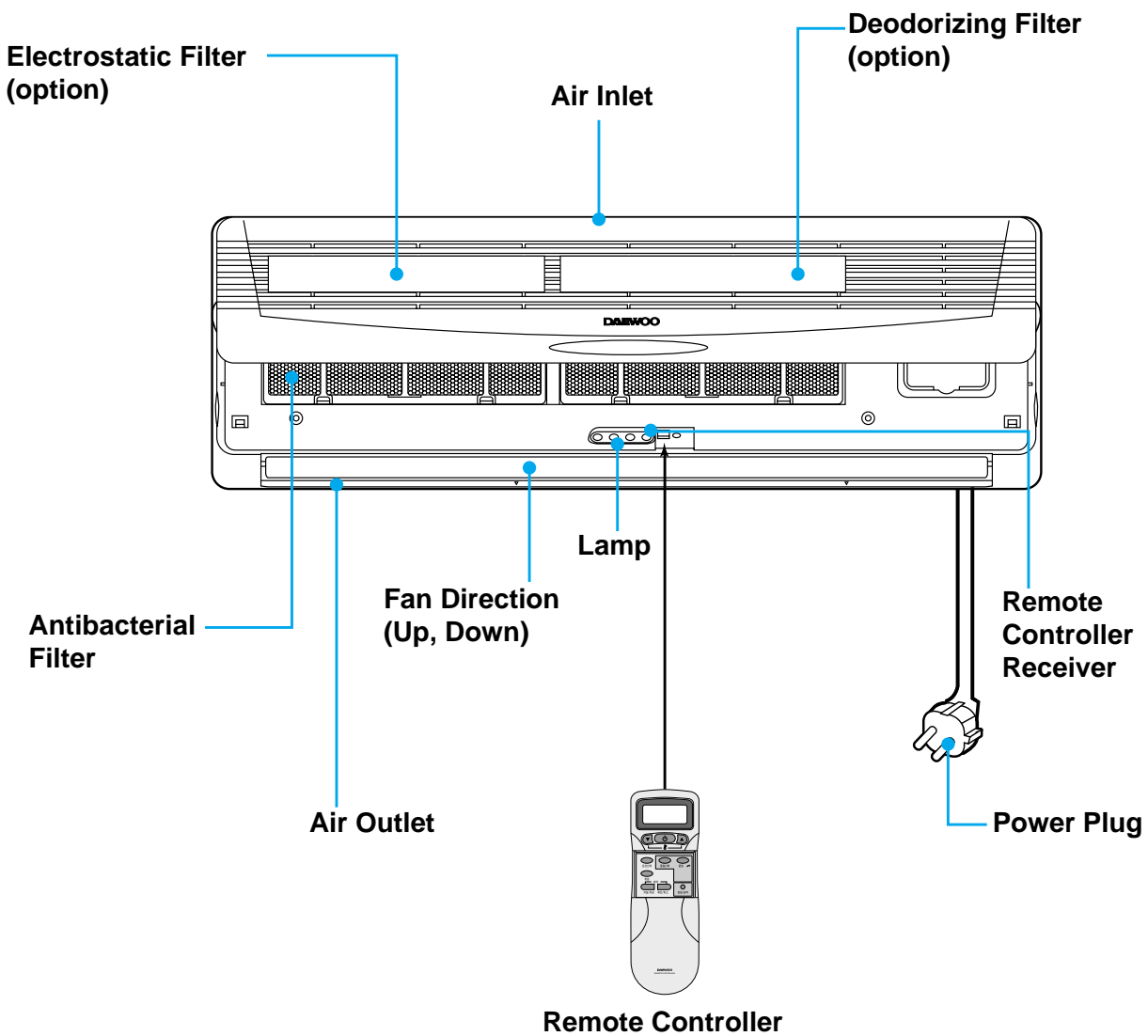

* DSB-121LH/122LH

Indoor Unit

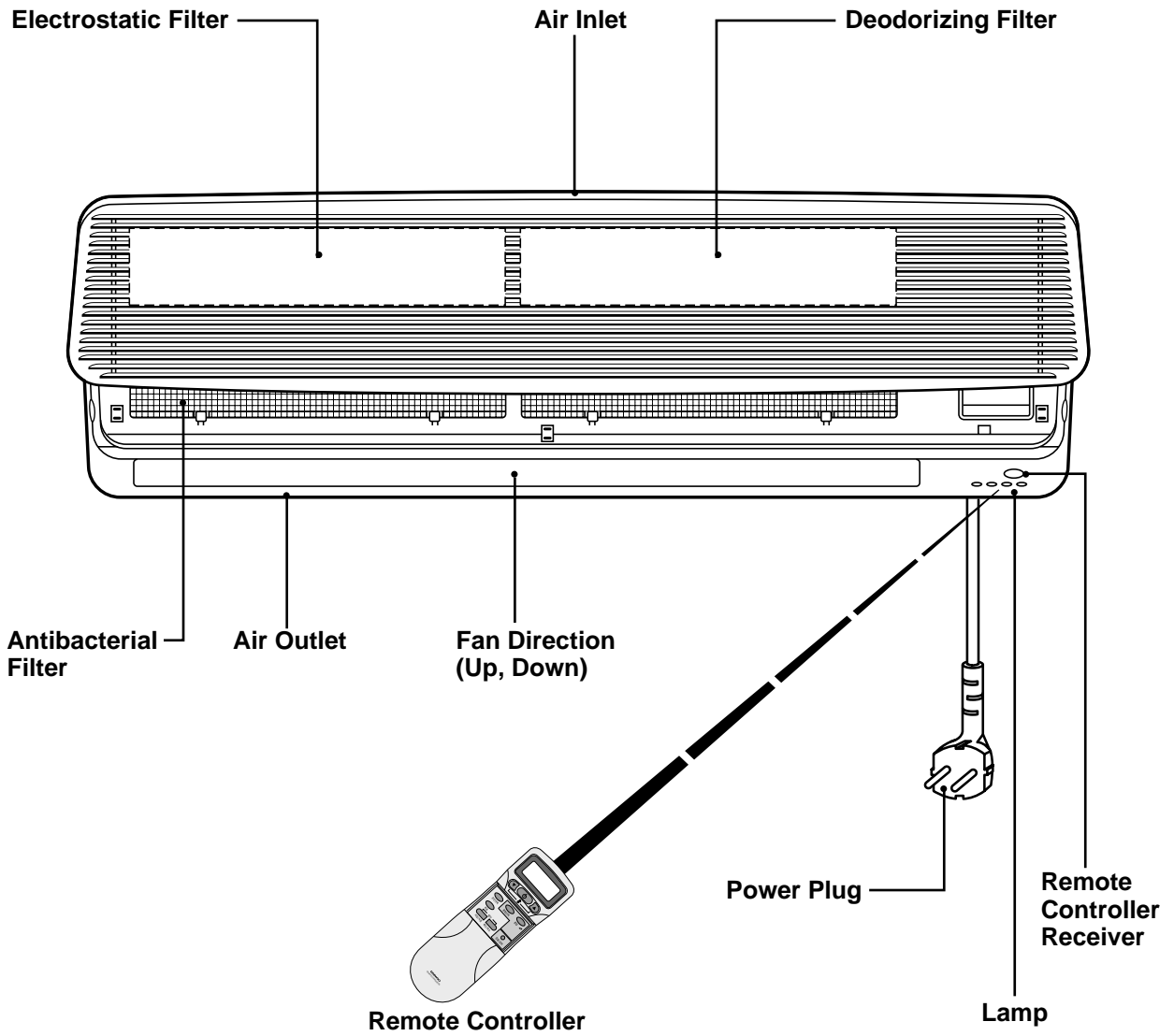

* DSB-070LH/DSB-091LH

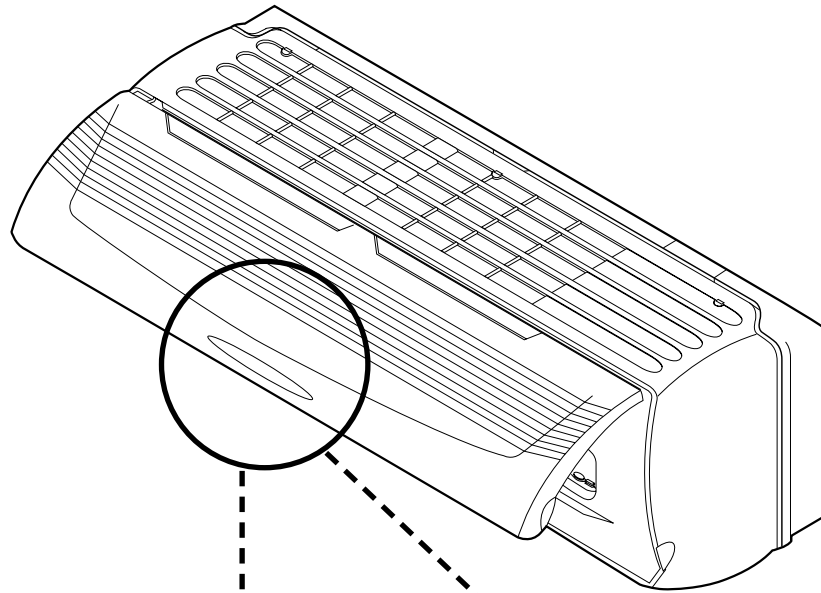

Indoor Unit Display

■ Remote Control Signal Receiver

This place is the part to receive the signal if it receive the signal, you can hear the signal “beep. beep.”



ON (Red)
Lights when the operation is going on.

Air clean (Green)

Timer (Yellow)
Lights during the time reservation mode.

Quick (Red)

Switch Panel

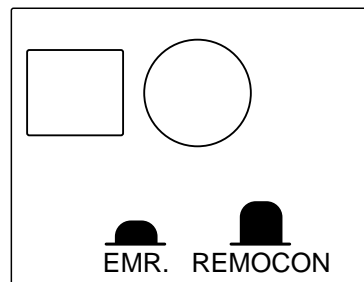

■ There is a switch panel at inside of Front Panel. At the time of operating, open the Front Panel.

Emergency switch can be used when the remote controller is lost or Testing.

Remote switch is usually used by remote controller.

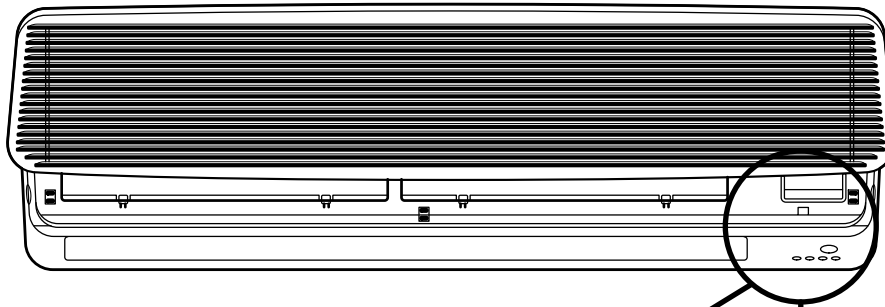

Indoor Unit Display

Remote Control Signal Receiver

This place is the part to receive the signal if it receive the signal, you can hear the signal "bep, beep".

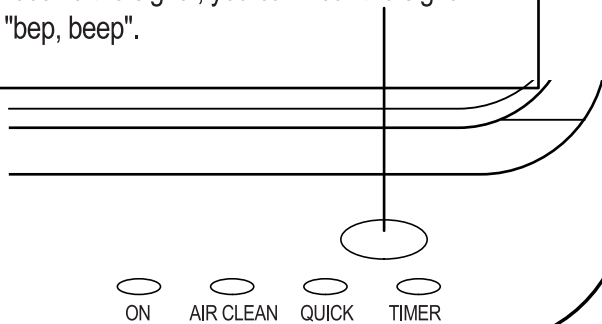

ON (Red)

Lights when the operation is going on.

Air clean (Green)

Timer (Yellow)

Lights during the time reservation mode

Quick (Red)

Switch Panel

EMERGENCY **REMOTE**

There is a switch panel at inside of Front Panel. At the time of operating, open the Front Panel.

Emergency switch can be used when the remote controller is lost or testing.

Remote switch is usually used by Remote Controller.

* DSB-240LH

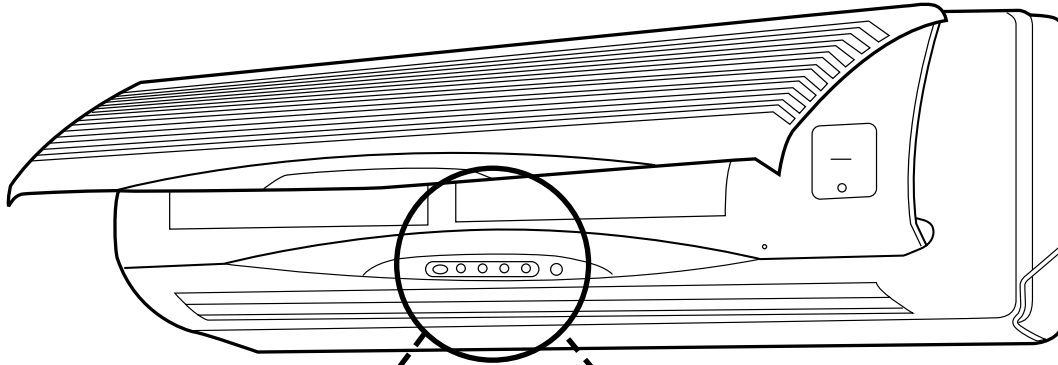

Indoor Unit Display

■ Remote Control Signal Receiver

This place is the part to receive the signal if it receive the signal, you can hear the signal “beep, beep.”



ON (Red)
Lights-on during the operation

Air clean (Green)
Lights-on during the operation

Timer (Yellow)
Lights-on during the time of reservation mode.

Quick (Red)
Lights-on during the time of Quick Mode.

Switch Panel

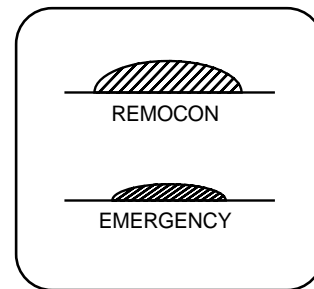

■ There is a switch panel at inside of Front Panel. At the time of operating, open the Front Panel.

Emergency switch can be used when the remote controller is lost or Testing.

Remote switch is usually used by remote controller.

* DSB-070LH/DSB-091LH/DSB-121LH/DSB-122LH(After)

Outdoor Unit

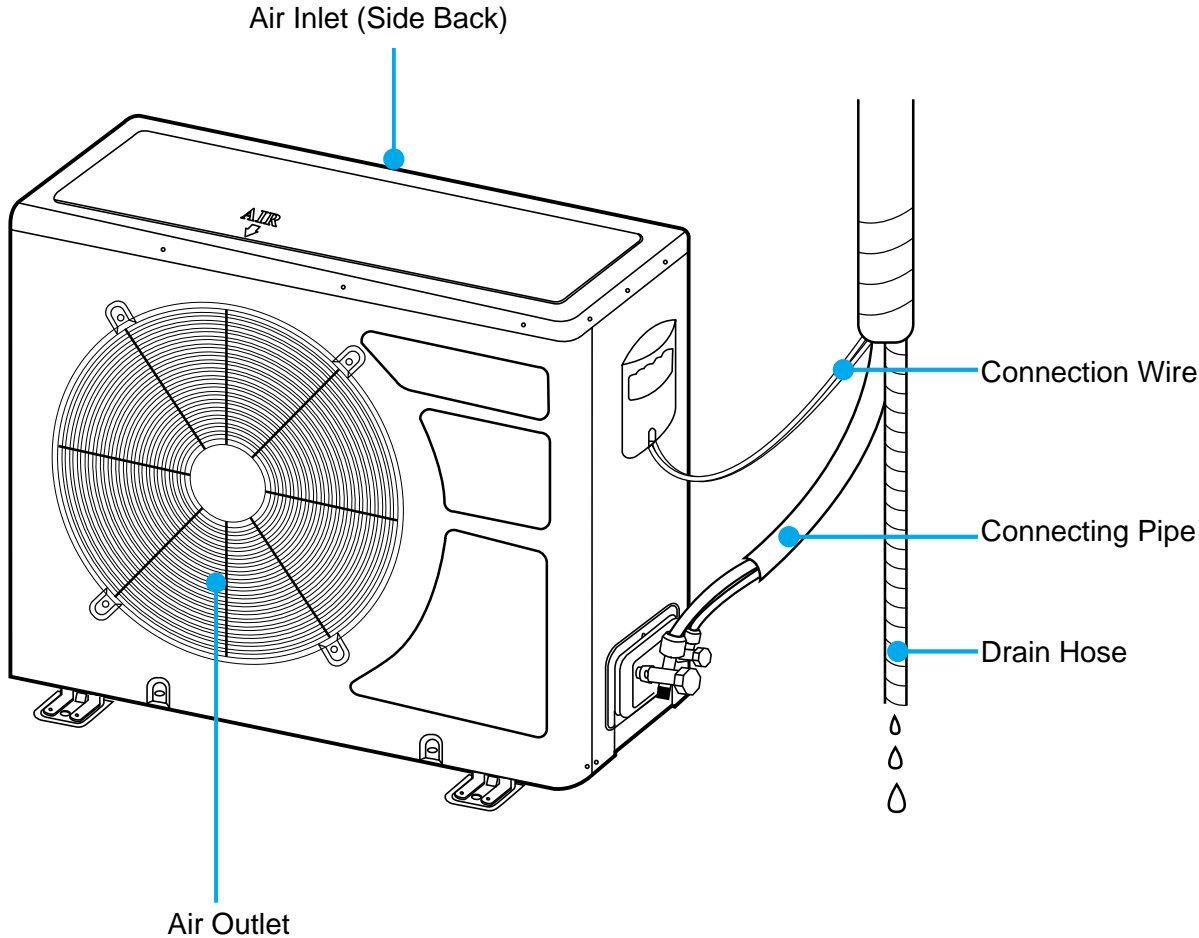

* DSB-121LH/DSB-122LH(Before)

Outdoor Unit

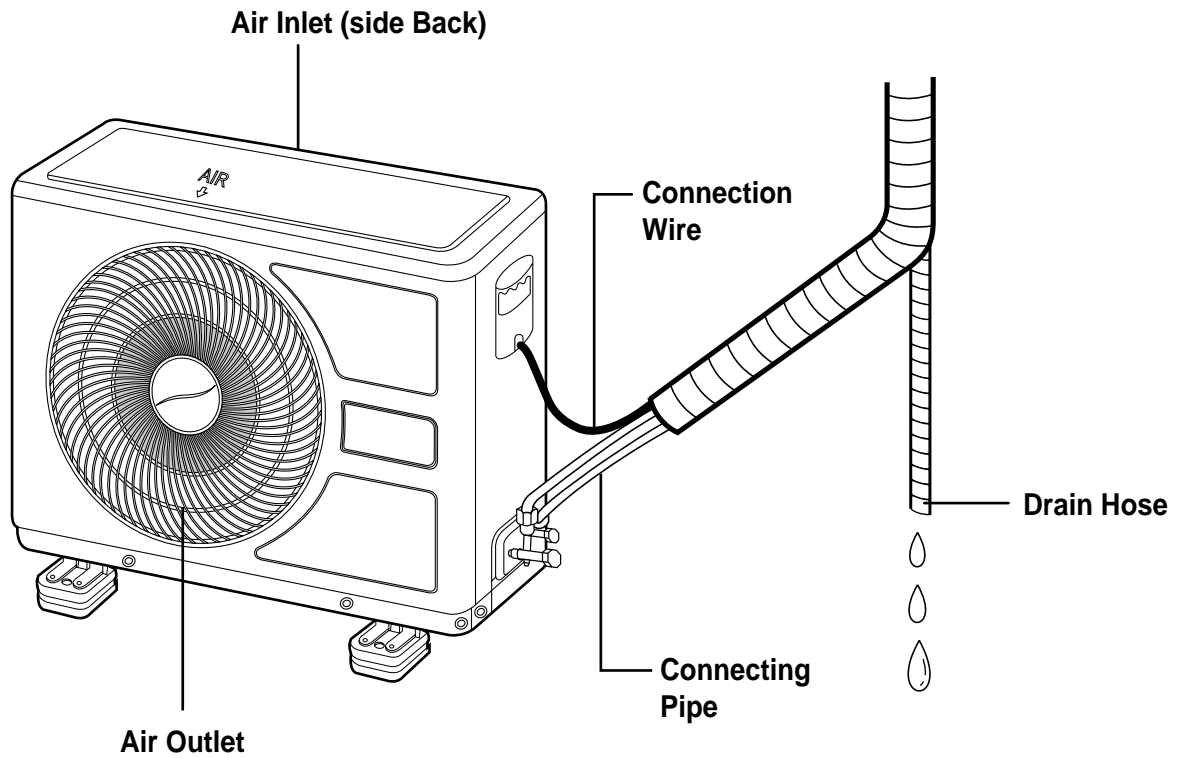

NOTE:

How to remove Top Panel

1. Loosen the screw at left and right side.
2. Push the three parts up Front and Back sides like figure orderly.
3. Unhook the locking parts of Top Panel.

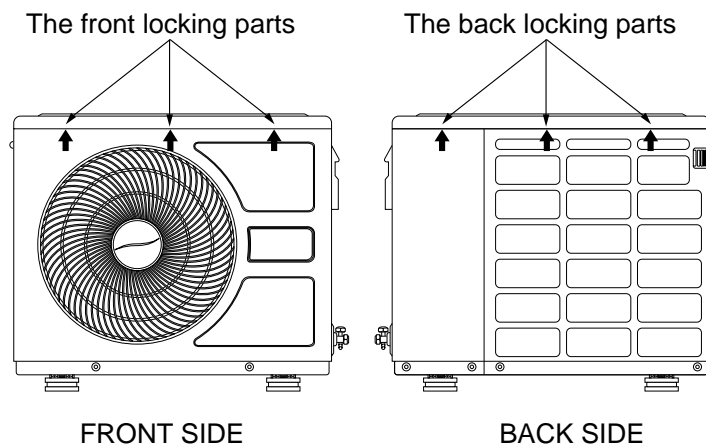

* DSB-240LH

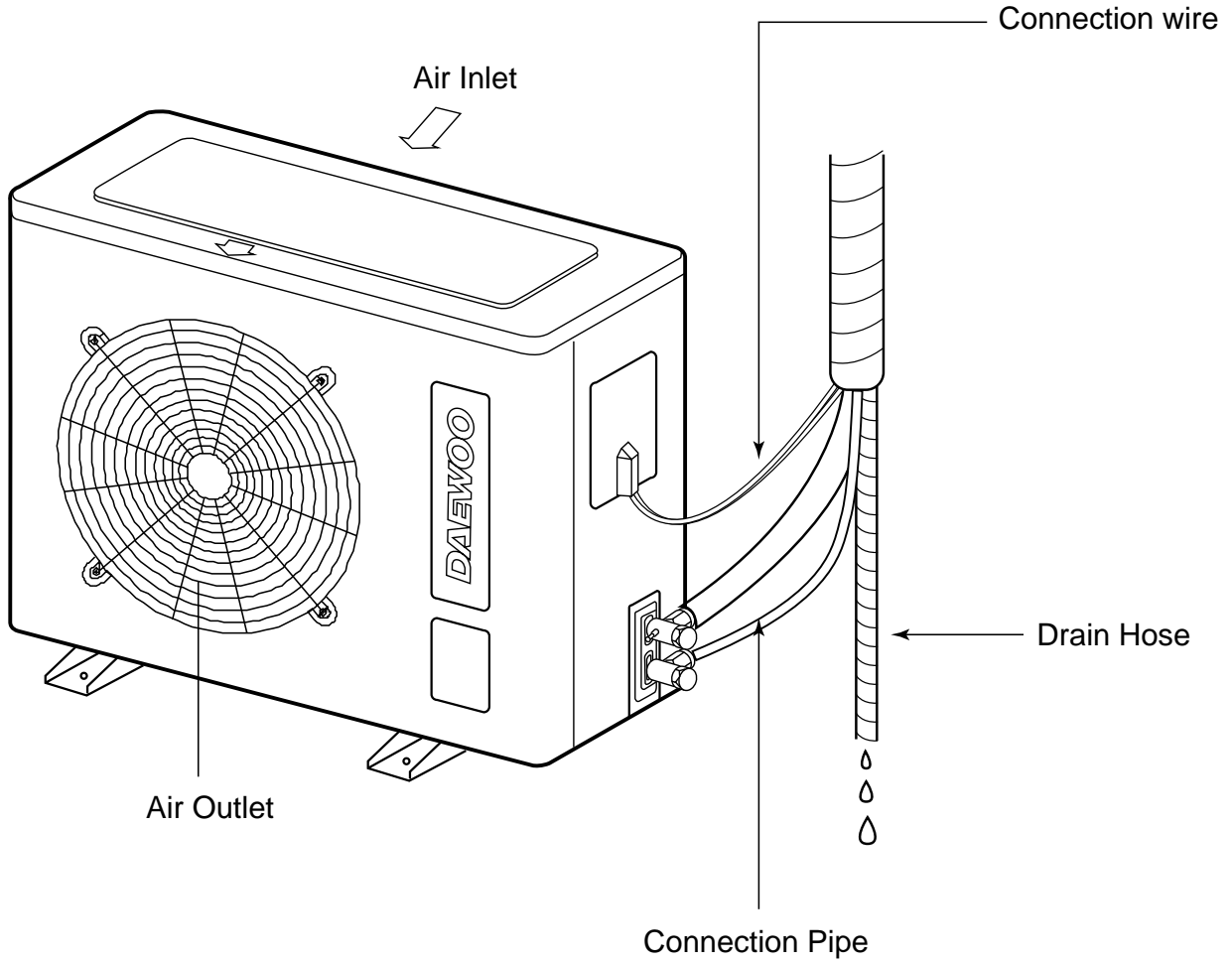

2 REMOTE CONTROLLER

* DSB-070LH/DSB-091LH/DSB-121LH/DSB-122LH/DSB-240LH

Name of Each Button

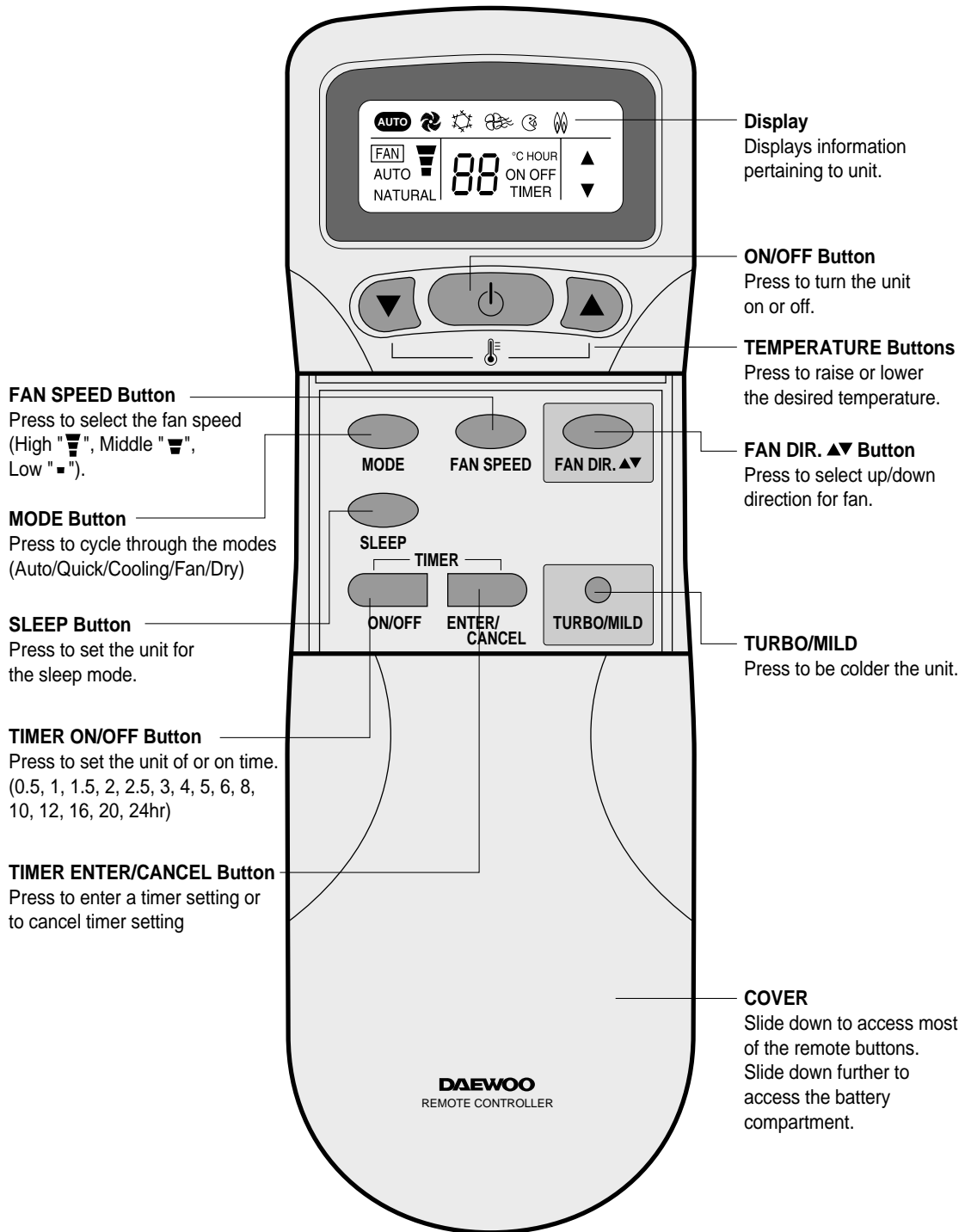

3 REMOTE CONTROLLER DISPLAY

DSB-070LH/DSB-091LH/DSB-121LH/DSB-122LH/DSB-240LH

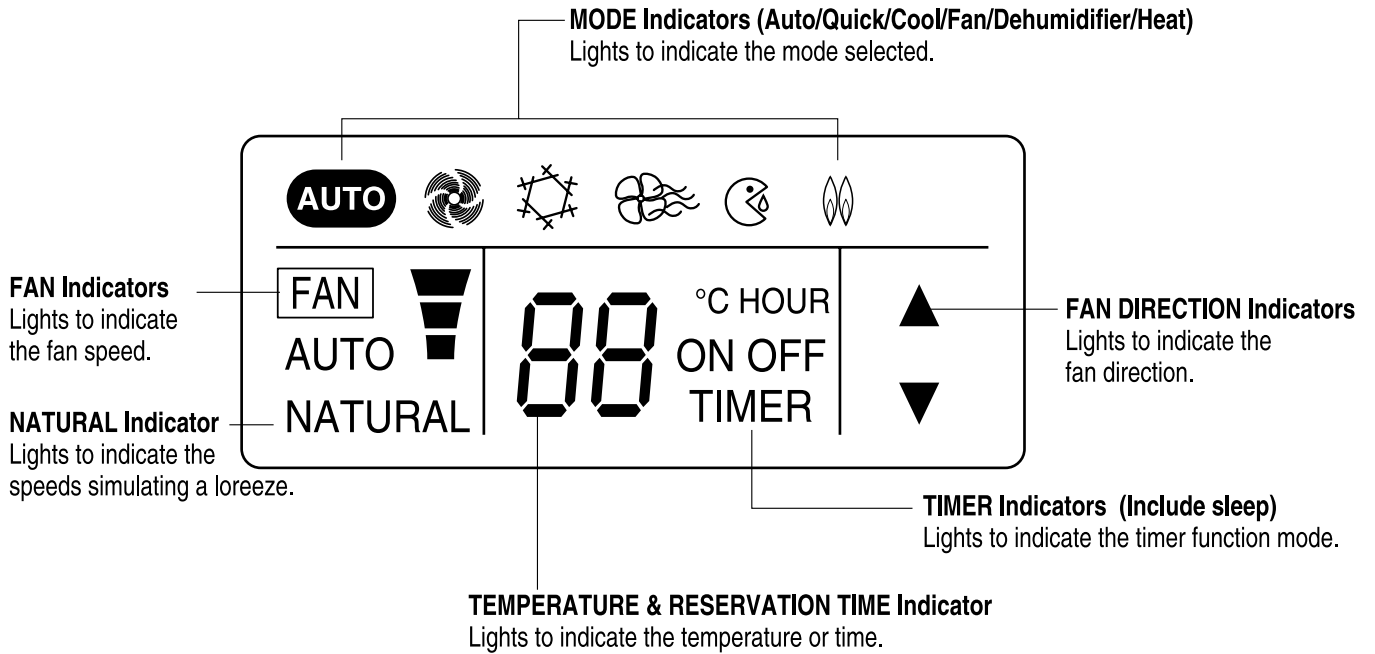

Replacing Batteries

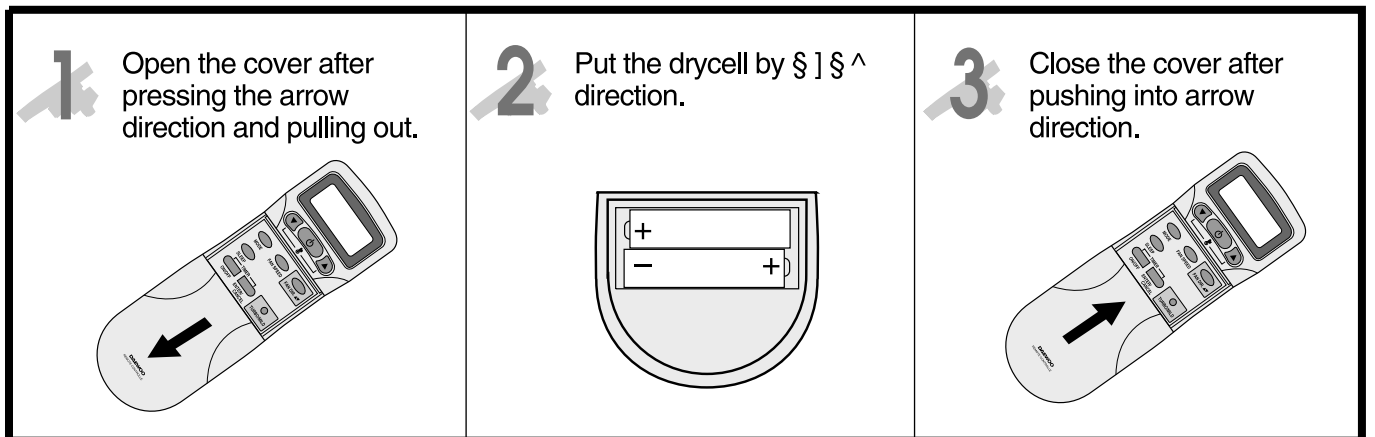

4 DESCRIPTION OF FUNCTIONS

OFF-Timer

If you set time in OFF-Timer Mode, the unit will stop at the set time.

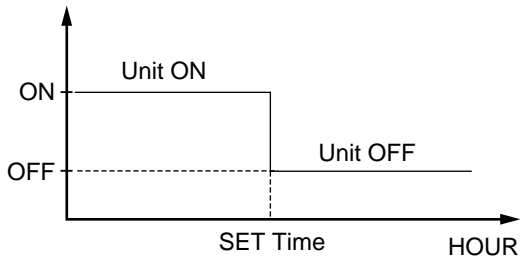

ON-Timer

If you set time in ON-Timer Mode, the unit will run at the set time.

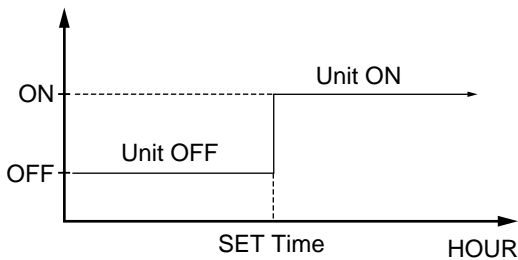

Control of Room Temperature

- (1) Range of setting temperature: 18~32°C
- (2) Setting temperature: Operating temperature of compressor

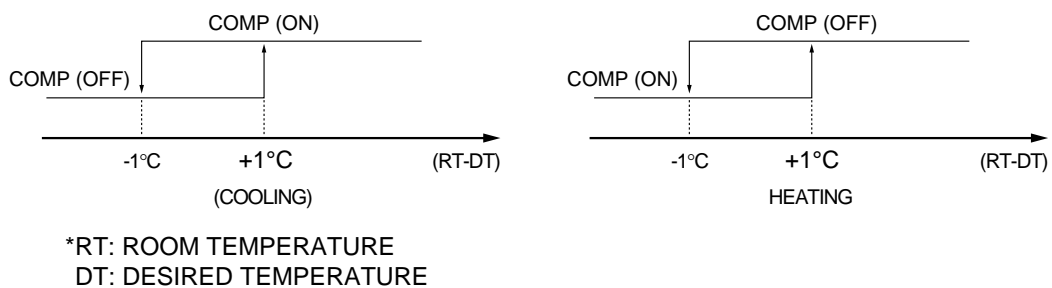

- (3) During the time of test operating, Fan (Indoor, Outdoor) and Compressor is running regardless of room temperature.

Buzzer

If the Indoor Unit Display receive the signal of Remote Controller, you can hear the signal "beep –" or "beep, beep".

- (1) In the case of receiving ON/OFF signal-"beep" "beep"
- (2) And so on-"beep"

Fan Speed (Indoor Unit)

- (1) Motor speed (Super high speed, high speed, normal speed, low speed, ultra low speed).
- (2) Remote controller setting fan speed. (Auto, L, M, H, Natural)
- (3) Relation of operating mode between fan speed. (legned: X-no relation)

	FAN ONLY	COOL	DEHUMI-DIFICATION	AUTO	QUICK	HEAT
H	H	H	L	H	H	H
M	M	M	L	M	H	M
L	L	L	L	L	H	L
Auto		Auto	L	Auto	H	Auto
Natural	Natural	Natural	L	Natural	H	Natural

(4) Automatic Operation

If the unit is set in 'AUTO' mode, the unit operates automatically according to the room temperature to keep the room temperature comfortable.

(COOLING)

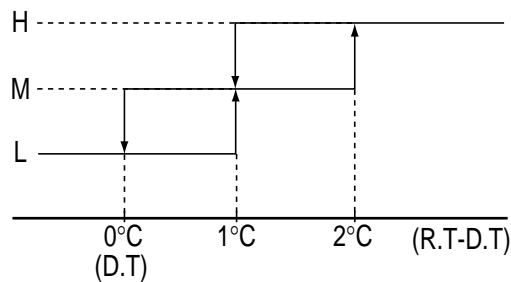

(HEATING)

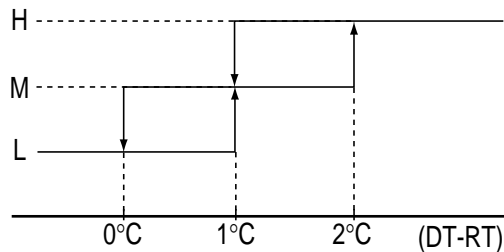

Sleep Mode

- (1) When you are going to sleep, select sleep switch and the unit controls the room to the desired temperature.
(The unit will not operate after 4 hour)
- (2) For changing the temperature.

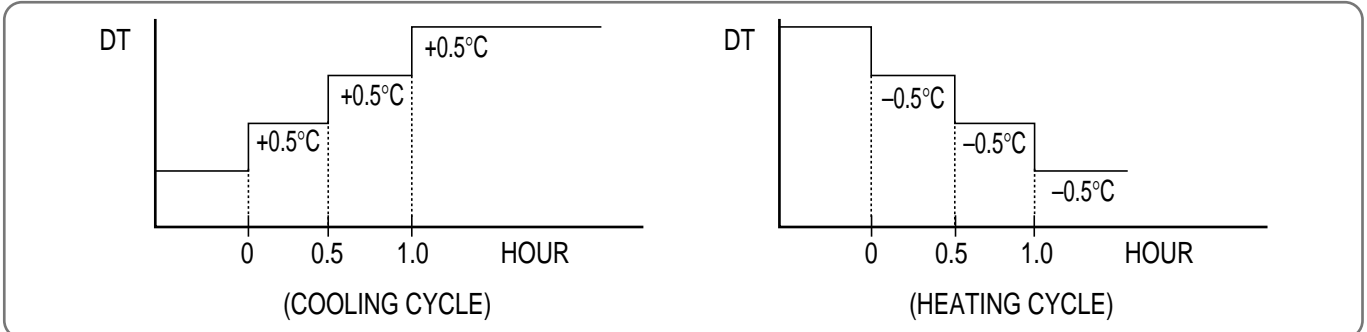

- (3) To cancel sleep mode, press the SLEEP button again or press the MODE button once.: the SLEEP indicator will disappear in the display.

Emergency Operation

- (1) When the remote controller is lost, damaged or the battery is discharged, the Emergency operation can be used to run the unit.
- (2) The setting conditions of Emergency operation are as follows.
 - * Operation mode: Quick
 - * Preset temperature: 18°C : Cooling, 32°C : Heating)
 - * Fan speed: High
 - * You cannot operate with remote controller.

Frost Prevention of Indoor Unit

When the unit operates at low ambient temperature, frost may appear on the Evaporator. When the indoor coil temperature is lower than 0°C at the end of 10 minutes of continuous compressor operation from the start, the microcomputer of the unit stops the compressor to protect the unit from the frost. The control procedure for indoor coil freeze protection.

- 1) The compressor and outdoor fan turn off.
- 2) Indoor fan operates according to user set speed.
- 3) The normal operation returns when the indoor coil temperature is higher than 7°C or equal to 7°C .

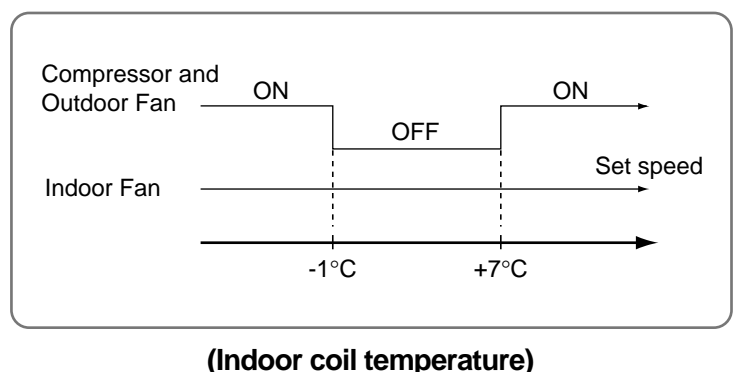

3 min. Time Delay of Compressor

In normal operation, there is a time delay of three minutes between turn off and turning back on including initial power up.

Auto Mode

(1) In Auto Mode

After the indoor fan is operated for 20 seconds in the Auto Mode the unit will operate automatically by selecting operating Mode according to the room temperature

(RT: Room temperature)

ROOM TEMPERATURE	OPERATING MODE	FLAP POSITION
$DT-2^{\circ}\text{C} > RT$	Heating	Heating Position
$DT-2^{\circ}\text{C} \leq RT \leq DT+3^{\circ}\text{C}$	Dehumidifier	Cooling Position
$DT+3^{\circ}\text{C} < RT$	Cooling	Cooling Position

(2) Selecting Operating Mode Again

Room temperature meets desired temperature and the compressor stops running over 30 minutes, then the unit selects operating Mode again.

Dehumidification Mode

- 1 Desired temperature < Room temperature
Outdoor Fan, Compressor : ON
Indoor Fan : Low speed
- 2 Desired temperature \geq Room temperature
Compressor : 3 min/ON, 5 min/OFF
Fan Speed : low speed
- 3 Room temperature \leq 18 C
Compressor : OFF
Fan speed : Low speed

Air Discharge Direction(only remote operation)

The air discharge direction procedure is below.

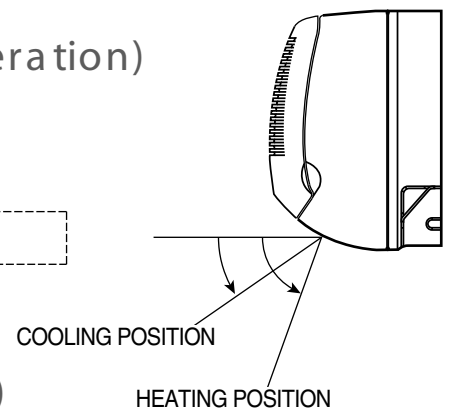
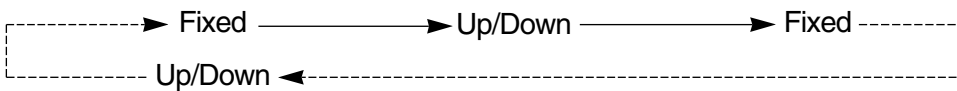

Quick Mode(Powerful Cooling & Heating)

1) Cooling Mode

* When the room temperature is higher than 22 C

- 1 Fan Speed: Super high speed
 - 2 Air discharge direction: Fixed
 - 3 Set temperature: 18 C (Fixed)
 - 4 Compressor and Outdoor Fan
- The air discharge direction procedure is below

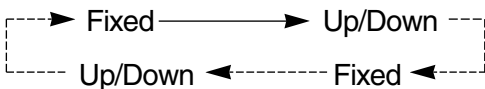

* The option is LEFT/RIGHT direction.

1) Heating Mode

* When the room temperature is higher than 22 C

- 1 Fan Speed: Super high speed
 - 2 Air discharge direction: Fixed
 - 3 Set temperature: 18 C (Fixed)
 - 4 Compressor and Outdoor Fan
- The air discharge direction procedure is below





* The option is LEFT/RIGHT direction.

Self-Diagnostic Function

The control will contain diagnostic test to verify the integrity of the system.

(1) Error Code Display Pattern

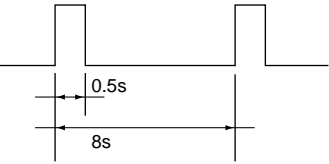
① ON LAMP: Blink

LED BLINK PATTERN	CASE	NOTE
 <p>1 times blink</p>	<p>Room Sensor open or Short</p>	<ul style="list-style-type: none"> • Continuously working to fix room temperature 18°C in heating mode. • Continuously working to fix room temperature 32°C in cooling mode
	<ul style="list-style-type: none"> • I/D coil sensor open or short • O/D coil sensor open or short 	Do not working
 <p>2 times blink</p>	<ul style="list-style-type: none"> • Compressor or electrical parts of compressor error. • Gas leak 	Continuously working

4. WIRING DIAGRAM

* DSB-070LH/DSB-091LH/DSB-121LH/DSB-122LH

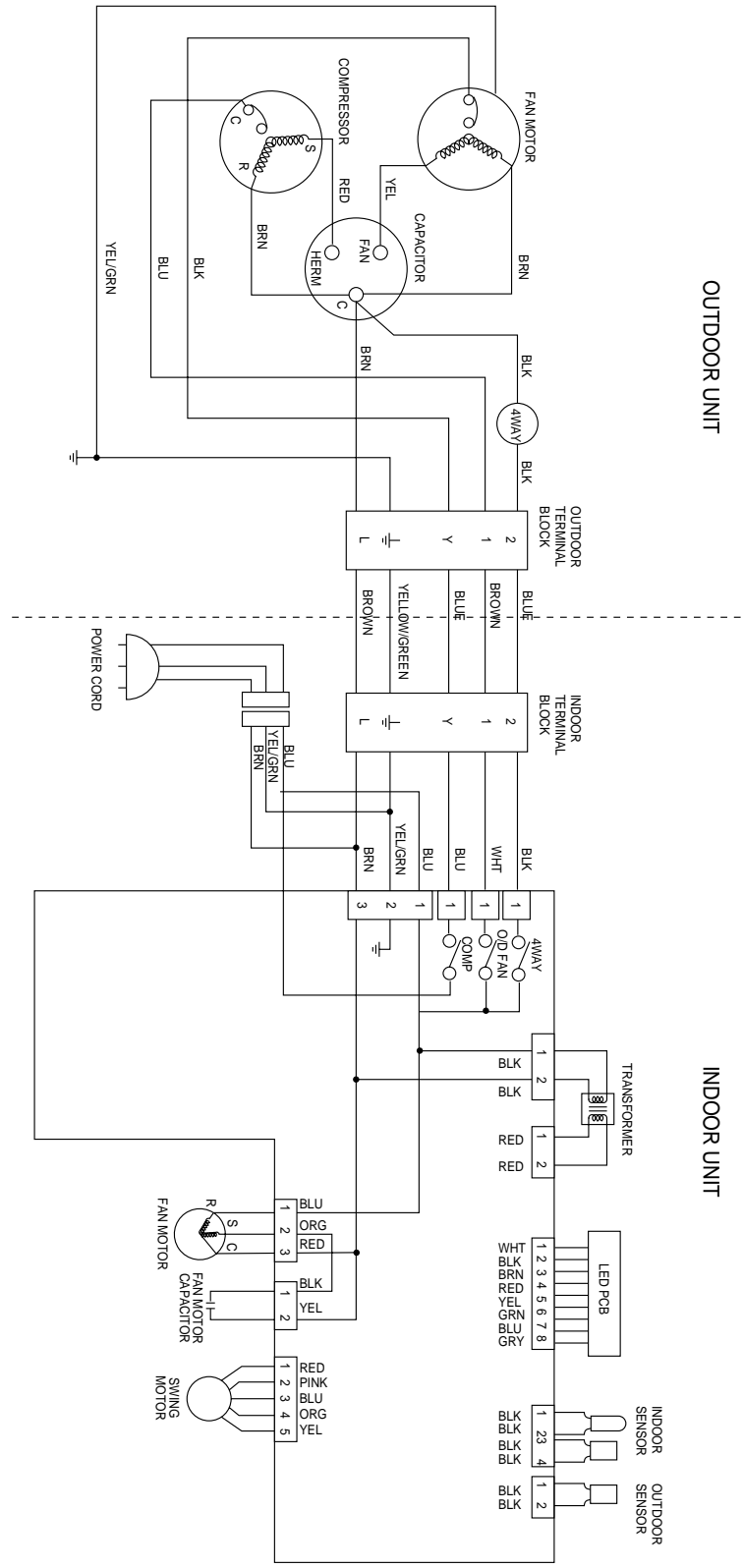

1 MAIN ELECTRIC PARTS

* DSB-070LH

	PART NAME	PART CODE	SPEC.	QUANTITY	REMARK
Indoor Unit	Fan Motor	3108003800	IC-8417DWKF5A	1	
	Fan Motor Capacitor	3106900300	1.0 μ F 400VAC	1	
	Fuse	5FVLB3152L	250V 3.15A	1	
	Transformer	5EPV050120	230V 50Hz	1	
	Stepping Motor	3108003900	GSP-24SW-061	1	
	Terminal Block	3108912301	SN-DBW-05P	1	
Outdoor Unit	Compressor	3107101200	QB134PL12B	1	
	Fan Motor	3108004000	IC-9625DWLF5A	1	
	Dual Capacitor	3109501201	1.8+25 μ F 400VAC	1	
	Terminal Block	3108912301	SN-DBW-05P	1	

* DSB-091LH

	PART NAME	PART CODE	SPEC.	QUANTITY	REMARK
Indoor Unit	Fan Motor	3108003800	IC-8417DWKF5A	1	
	Fan Motor Capacitor	3106900300	1.0 μ F 400VAC	1	
	Fuse	5FVLB3152L	250V 3.15A	1	
	Transformer	5EPV050120	230V 50Hz	1	
	Stepping Motor	3108003900	GSP-24SW-061	1	
	Terminal Block	3108912301	SN-DBW-05P	1	
Outdoor Unit	Compressor	3RC0020KE0	RBB100A001	1	
		3107101900	QK185PN13F	1	
	Fan Motor	3108004100	IC-9630DWLF5A	1	
	Dual Capacitor	3109502010	1.8+30 μ F 400VAC	1	
		3109502030	1.8+35 μ F 400VAC	1	
	Terminal Block	3108912301	SN-DBW-05P	1	
	Reversing Valve	3104401010	CHV-0104	1	
Solenoid coil	3109700110	CHV01AJ	1		

* DSB-121LH/122LH

	PART NAME	PART CODE	SPEC.	QUANTITY	REMARK
Indoor Unit	Fan Motor	3108001220	IC-8428DWKG7C	1	
	Fan Motor Capacitor	3106900300	1.0 μ F 400VAC	1	
	Fuse	5FVLB3152L	250V 3.15A	1	
	Transformer	5EPV050100	220V/18V	1	
	Stepping Motor	3108000100	MP28GA (L=400mm)	1	
	Terminal Block	3108912301	SN-DBW-05P	1	
Outdoor Unit	Compressor	3100030CE0	RCB150A001	1	
	Fan Motor	3108000800	IC-9430DWLC5A	1	
	Dual Capacitor	3109500700	3.5+25 μ F 400VAC	1	
	Terminal Block	3108912301	SN-DBW-05P	1	
	Reversing Valve	3105401000	VH7-A TYPE	1	
	Solenoid coil			1	

* DSB-240LH

	PART NAME	PART CODE	SPEC.	QUANTITY	REMARK
Indoor Unit	Fan Motor	3108007500	IC-9430DWKG7A	1	
	Fan Motor Capacitor	3106902400	2.0uF 400VAC	1	
	Fuse	5FVLB3152L	250V 3.15A	1	
	Transformer	5EPV050120	230V/50Hz	1	
	Stepping Motor	3108007600	GSP-24RW-062	1	
	Terminal Block	3108912320	SN-DBW-062	1	
Outdoor Unit	Compressor	3100068201	AWG-5530EXC	1	
	Fan Motor	3108007400	OSME986DERC 230/50	1	
	Dual Capacitor	3109508100	5/45μF 400VAC	1	
	Terminal Block	3108912320	SN-DBW-4P	1	
	Reversing Valve	3105400310	CHV-0201 SAGINDMIYA	1	
	Solenoid coil	3109700110	CHV-01AJ506B1	1	

5. REFRIGERANT CYCLE

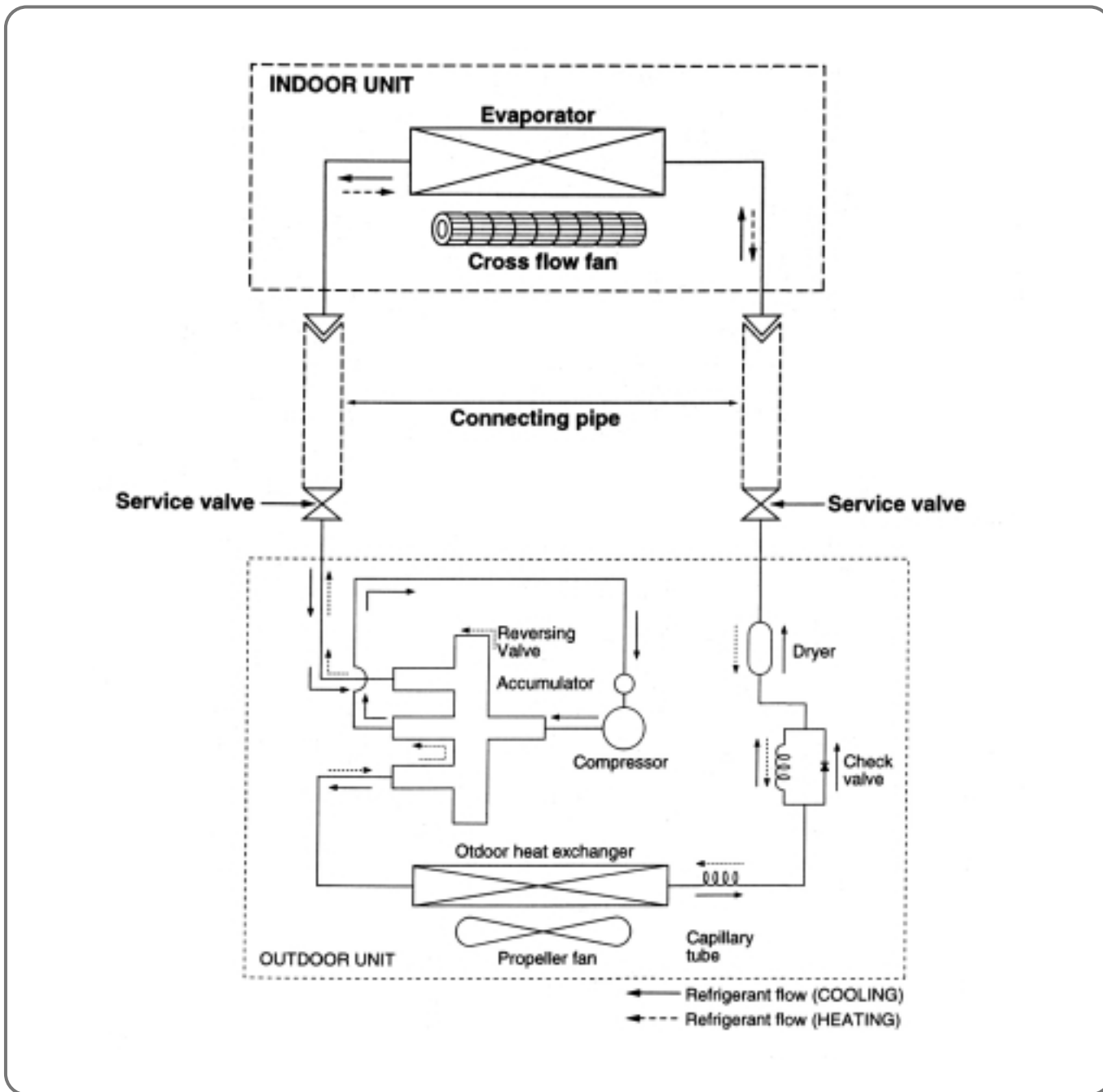

Note) If the pipe length exceeds the standard length, add 30g of refrigerant per extra meter.

Model Name		DSB-070LH	DSB-091LH	DSB-121LH/122LH	DSB-240LH
Contents	Cool	IDØ1.78 x ODØ3.2 x 500L	IDØ1.8 x ODØ3.2 x 800L	IDØ1.8 x ODØ3.2 x 500L	IDØ2.0 x ODØ3.2 x 600L
	Heat	IDØ1.78 x ODØ3.2 x 700L	IDØ1.78 x ODØ3.2 x 1,000L	IDØ1.8 x ODØ3.2 x 900L	IDØ2.0 x ODØ3.2 x 300L
Charge Quantity		900 g	1,150 g	1,060 g	2,200 g

6. CONTROL BLOCK DIAGRAM

* DSB-070LH/DSB-091LH/DSB-121LH/DSB-122LH/DSB-240LH

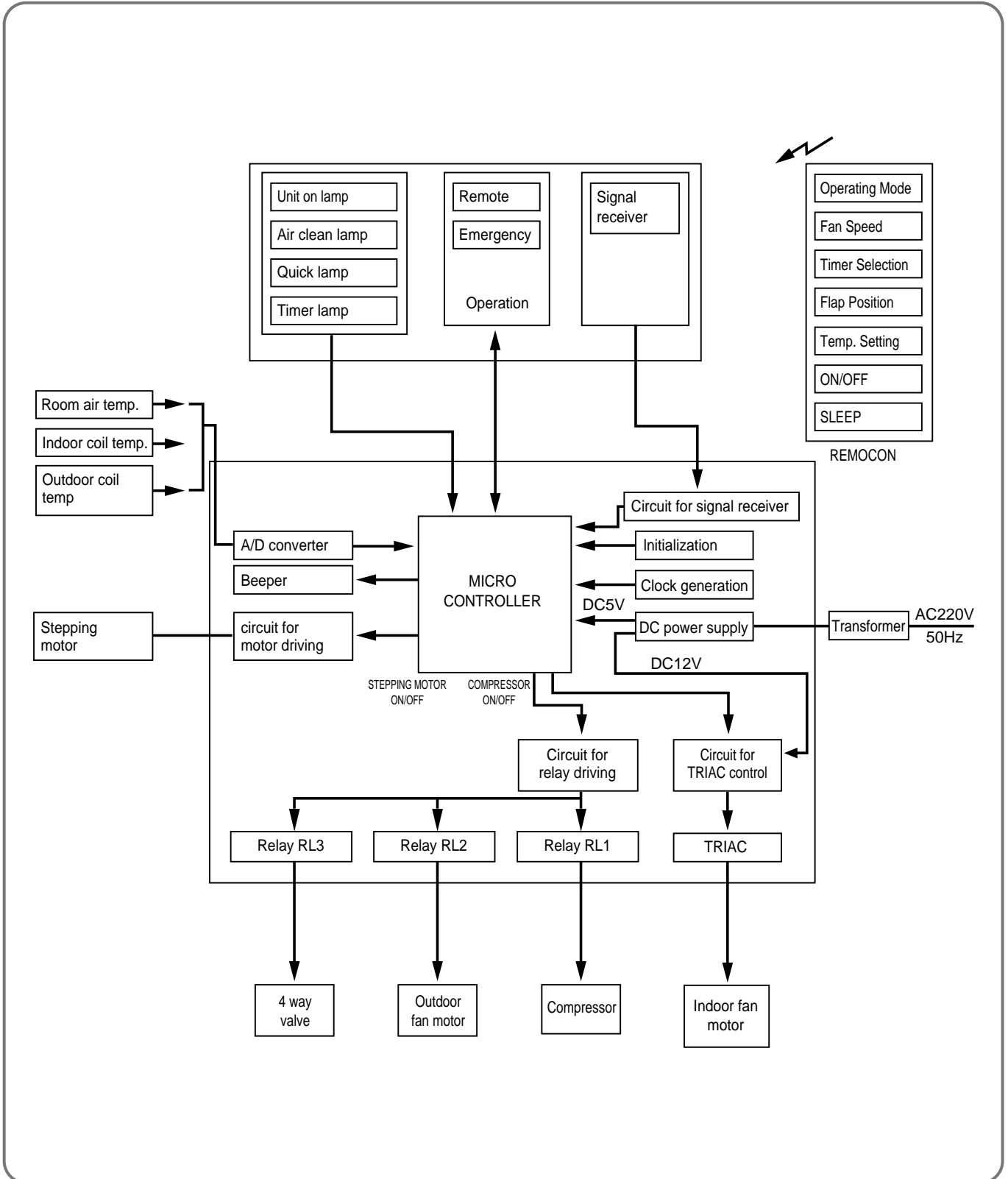

7. ELECTRIC CIRCUIT DIAGRAM

1 ELECTRIC CIRCUIT DIAGRAM

* DSB-070LH/DSB-091LH/DSB-121LH/DSB-122LH

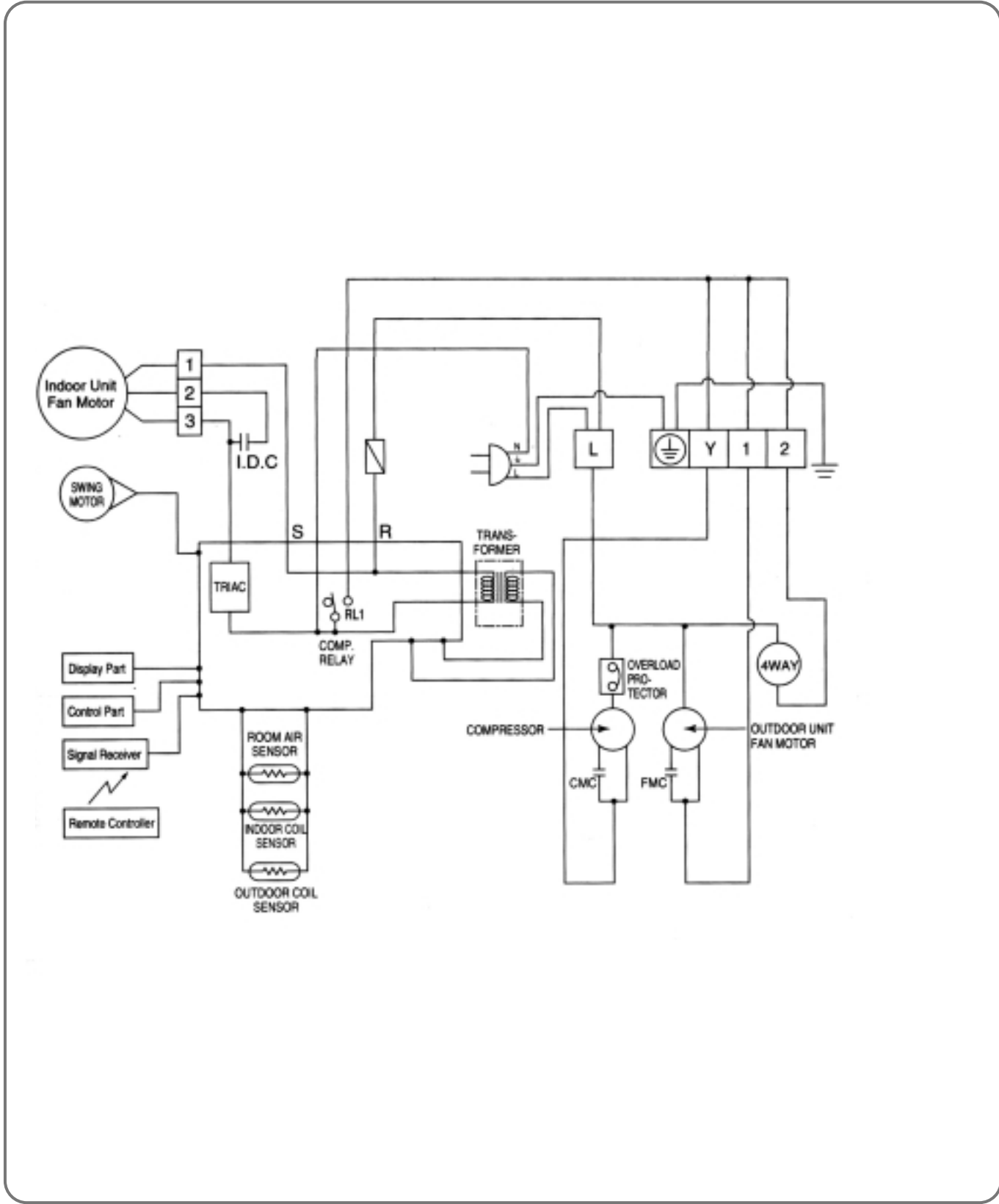

Description

1. After the power ON/OFF button is pressed once, the relay and triac are turned ON or OFF per the remote control setpoint.
 - TRIAC is controlled per the fan speed selection.
 - RELAY is controlled per the operation mode selection.
2. If the power ON/OFF button is pressed once more, the relay and triac are turn off and the unit stops operation.
3. The unit turns on or off according to the temperature set point by sensing the room air temperature through thermistor.
4. If the fan speed selection is set to the auto position, the fan speed is automatically controlled according to the temperature difference between room temperature and temperature set point.
5. If you press the ON/OFF button during operating the unit, Relay and LED is OFF and the unit is OFF.

8. TROUBLE SHOOTING

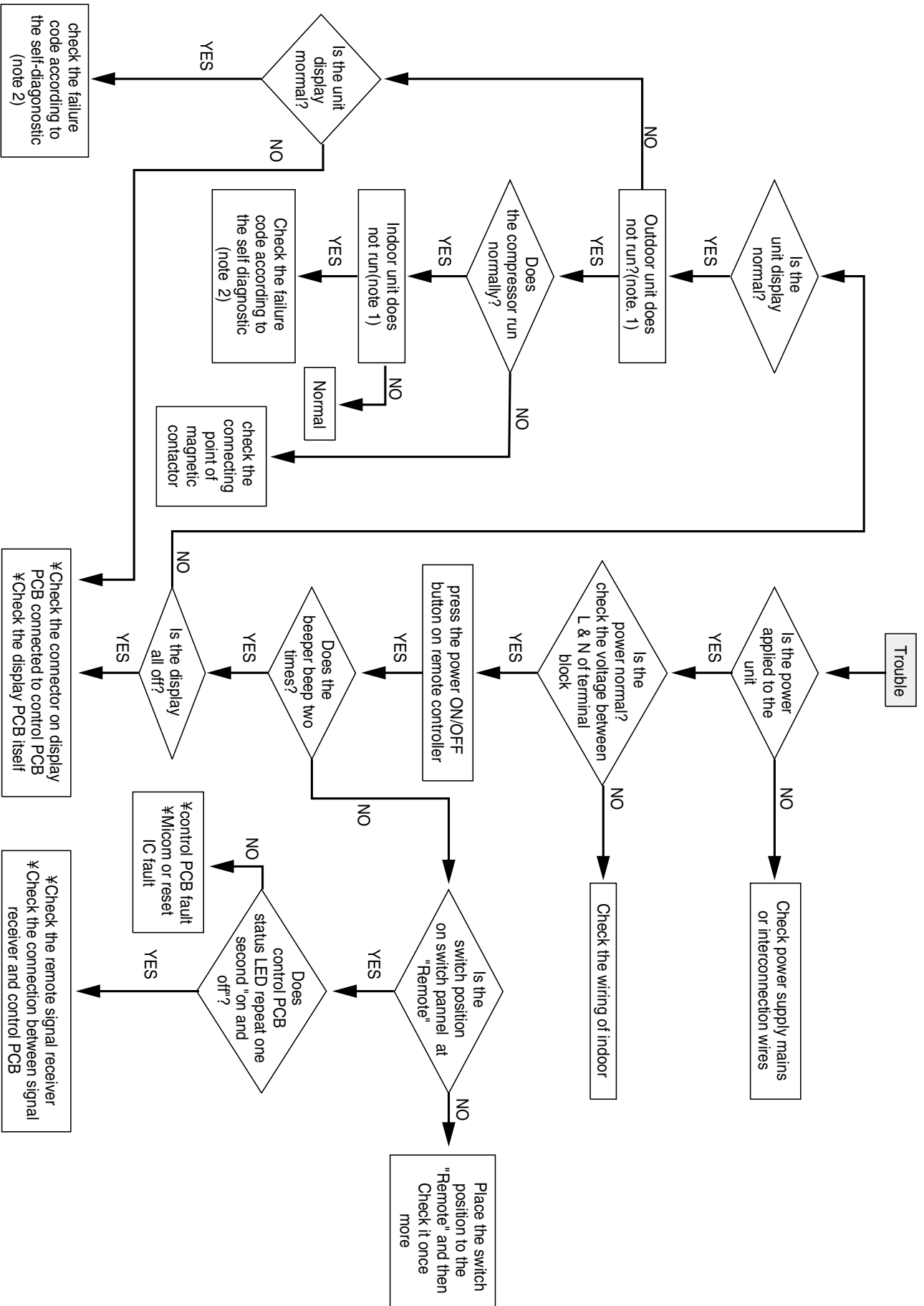

Note 1)

- ① Neither indoor unit nor outdoor unit runs.
Check the following points first. (There are following case in normal operation)
 - a. Is the timer mode set the "timer ON".
 - b. Is the timer mode set the "timer-OFF" and the time had passed?
- ② Neither outdoor fan nor compressor runs while indoor fan runs.
Check following points first. (There are following cases in normal operation)
 - a. Is the temperature set point suitable?
 - b. Has the 3 minutes time guard for compressor operated?

Self-Diagnostic Function

• Error Code •

- ① When the compressor do not run.
 - i) Check the voltage between **L** and **Y** of terminal block.
(Indoor Unit, Outdoor Unit)
 - ii) Check connecting wire of indoor unit and outdoor unit.
 - iii) Check relay RL1 on power P.C.B
- ② Check fixing of indoor coil thermistor.
- ③ Check the GAS LEAKAGE of the pipe.

Neither Indoor Unit nor Outdoor Unit Runs

Confirm following statement.

When the unit operate normally, Sometimes the outdoor unit and indoor unit cannot operate.

- ① Check the function select switch. Is it timer mode?
- ② The function select switch locate the sleep mode and is the setting time over?
- ③ Is the setting mode DEHUMIDIFIER mode?
- ④ When the unit is DEHUMIDIFIER mode while in the auto mode, the outdoor unit and indoor unit does not run.

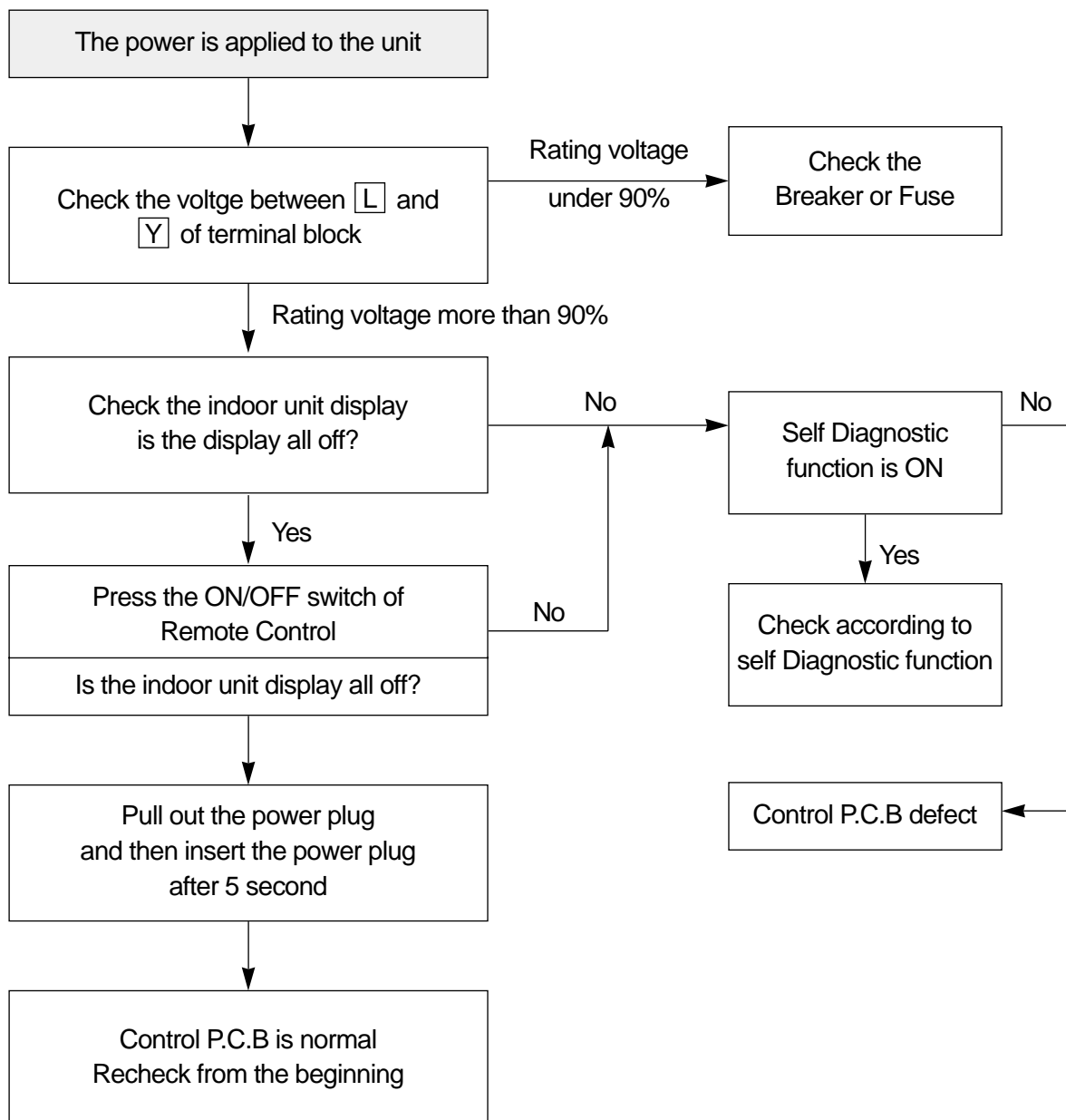

Outdoor Unit Runs but Indoor Fan Do Not Run

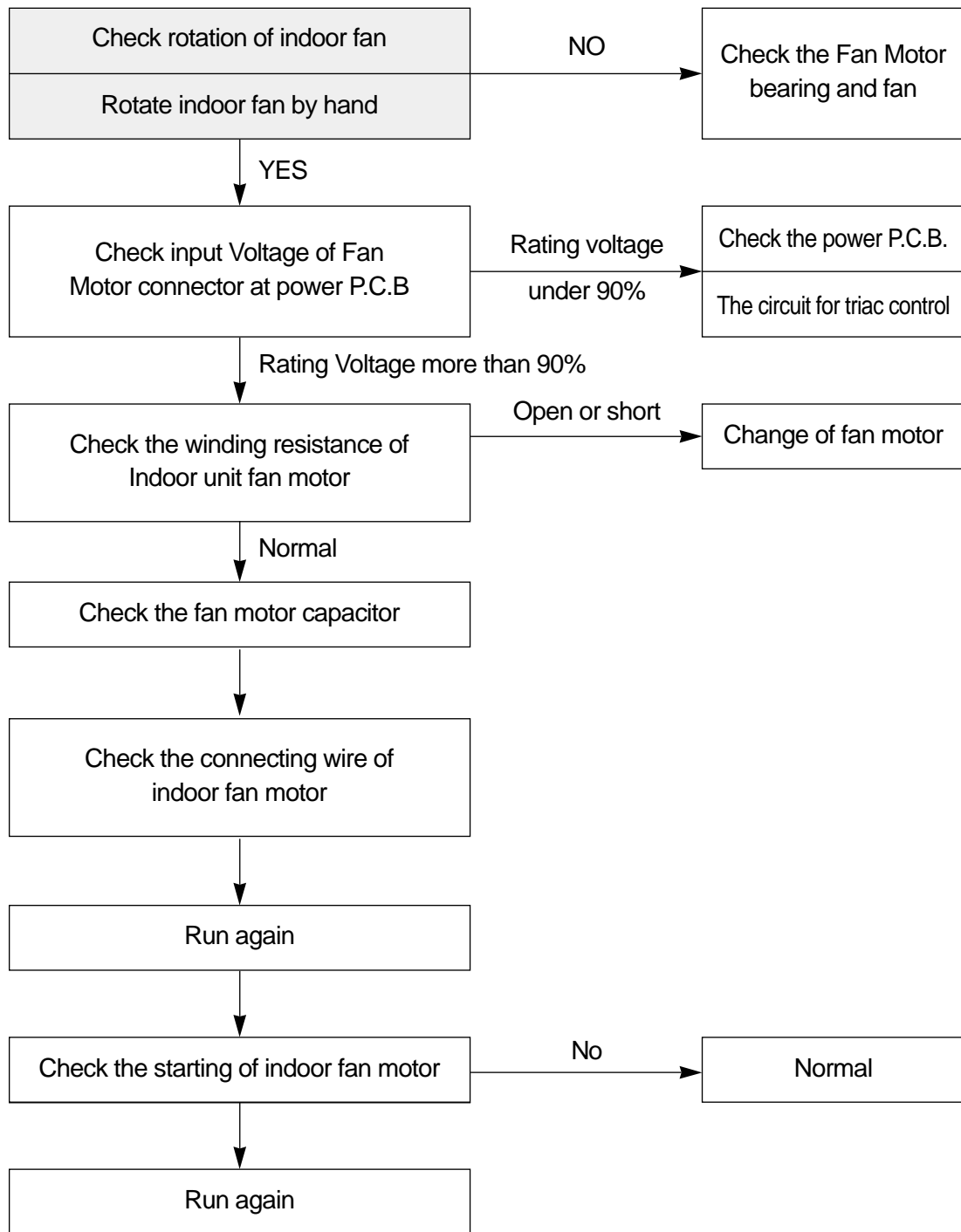

Outdoor Fan and Compressor Do Not

Confirm following statement.

When the unit operate normally, Sometimes the outdoor unit and indoor unit cannot operate.

- ① Is the setting temperature proper?
- ② Is the unit during 3min. Time delay of compressor.
- ③ During frost prevention of Indoor unit.
- ④ During dehumidifier mode.

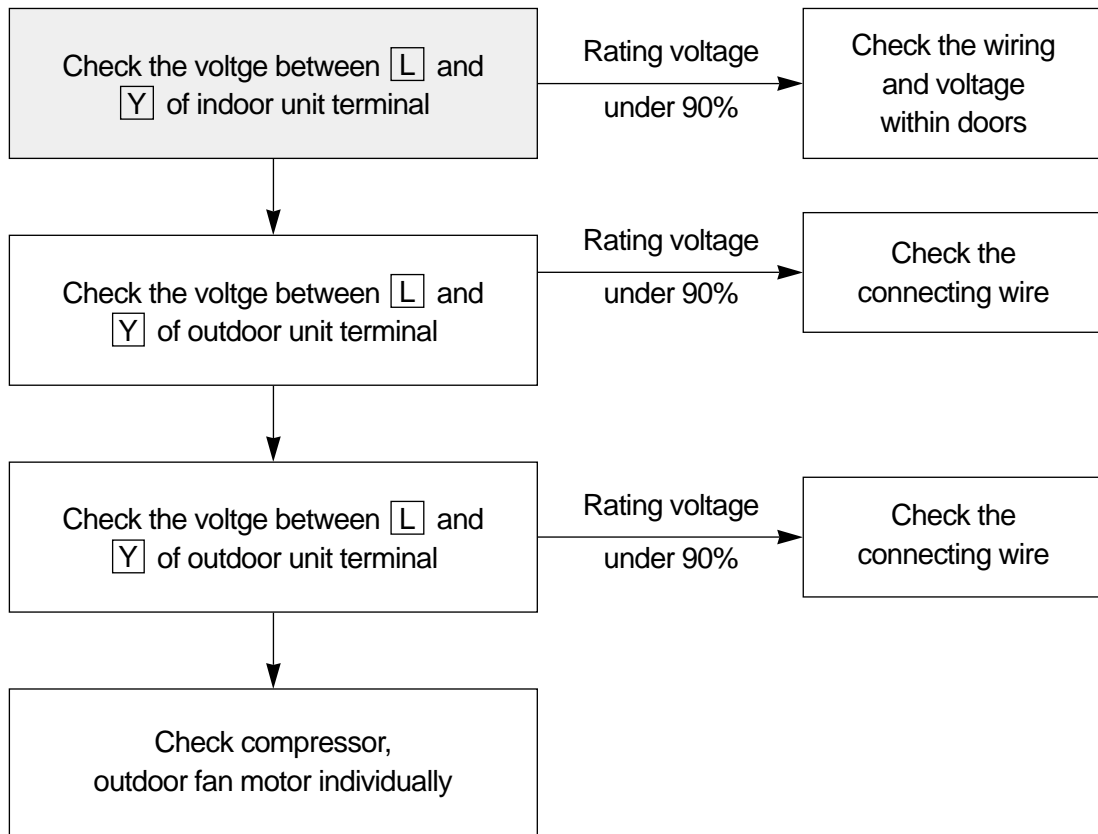

Only Compressor Do not Run

- Check the following at cooling mode

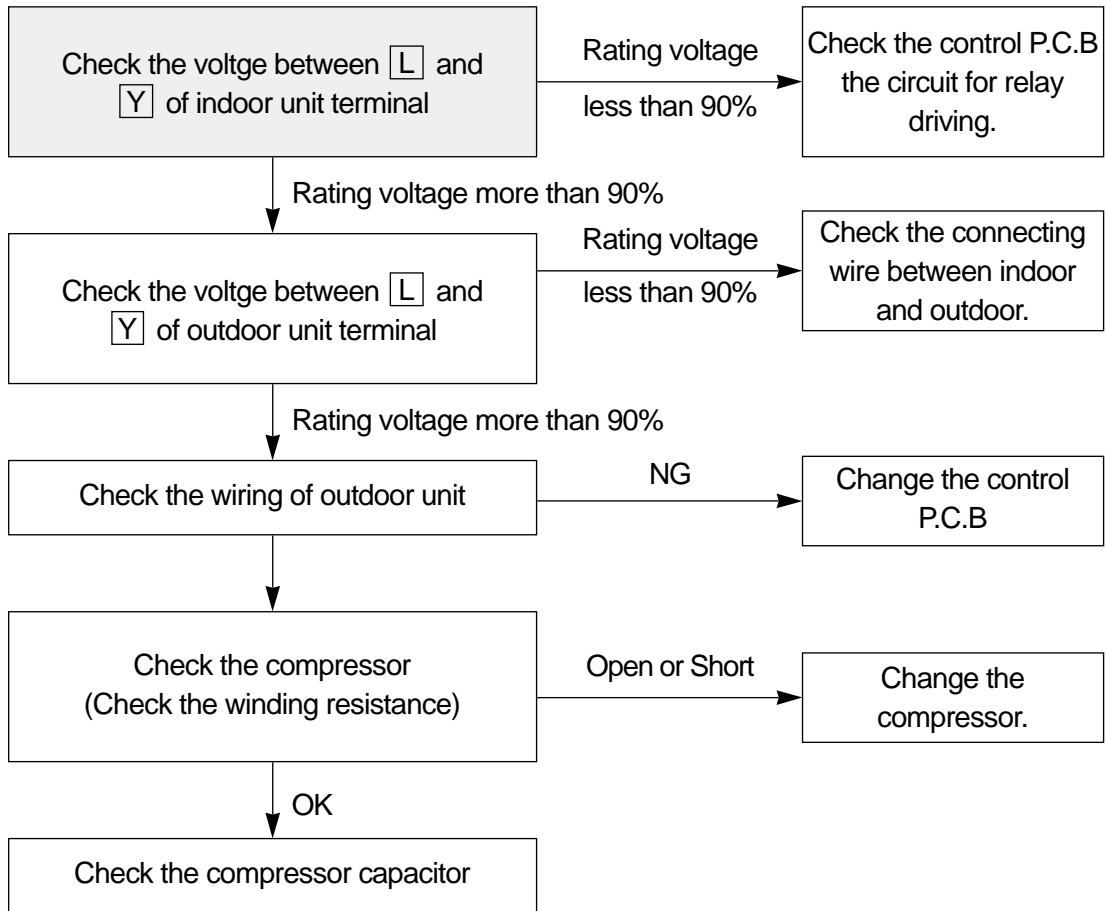



PCB DRIVING DESCRIPTION

1 PCB CIRCUIT DIAGRAM

* DSB-070LH/DSB-091LH/DSB-240LH

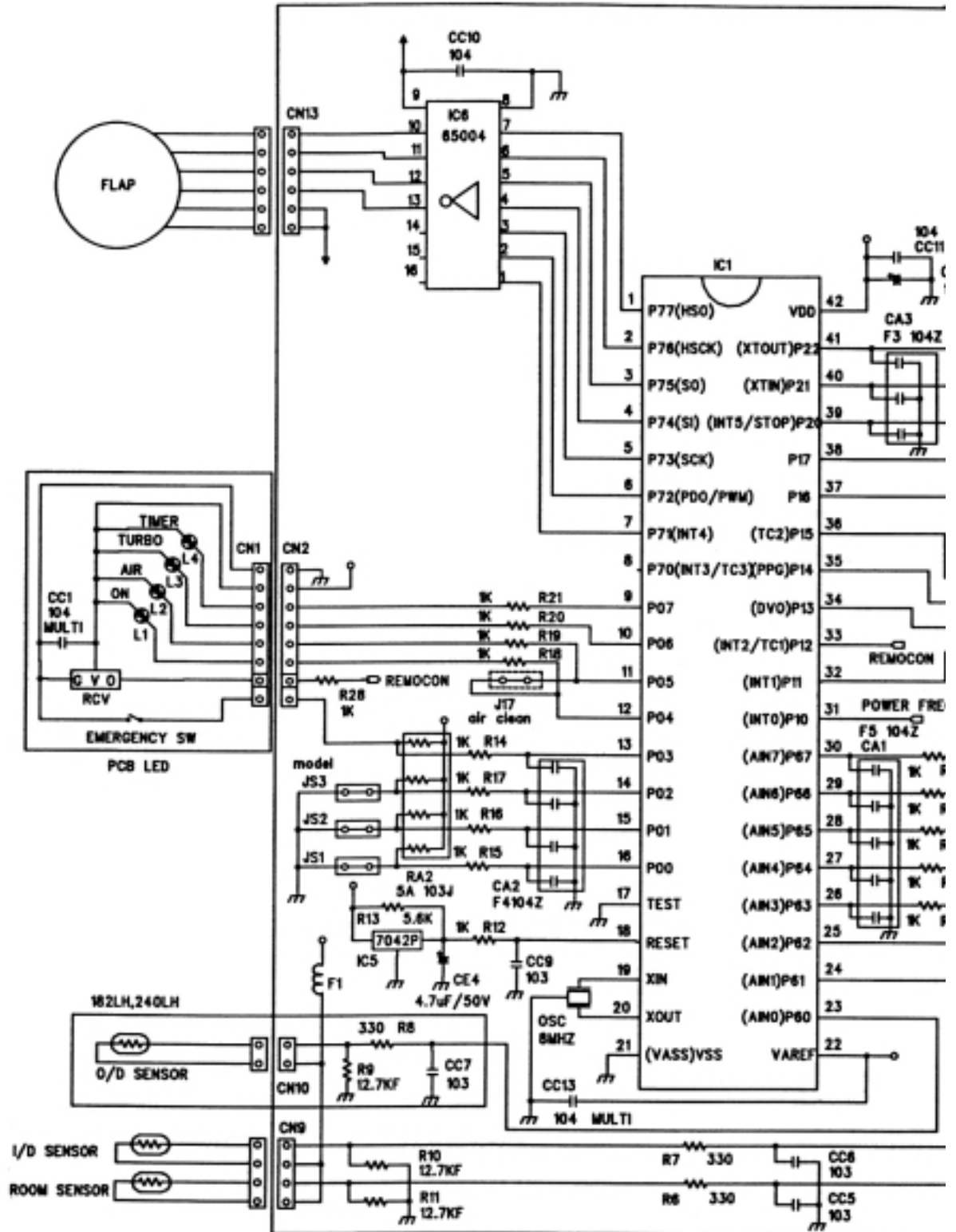

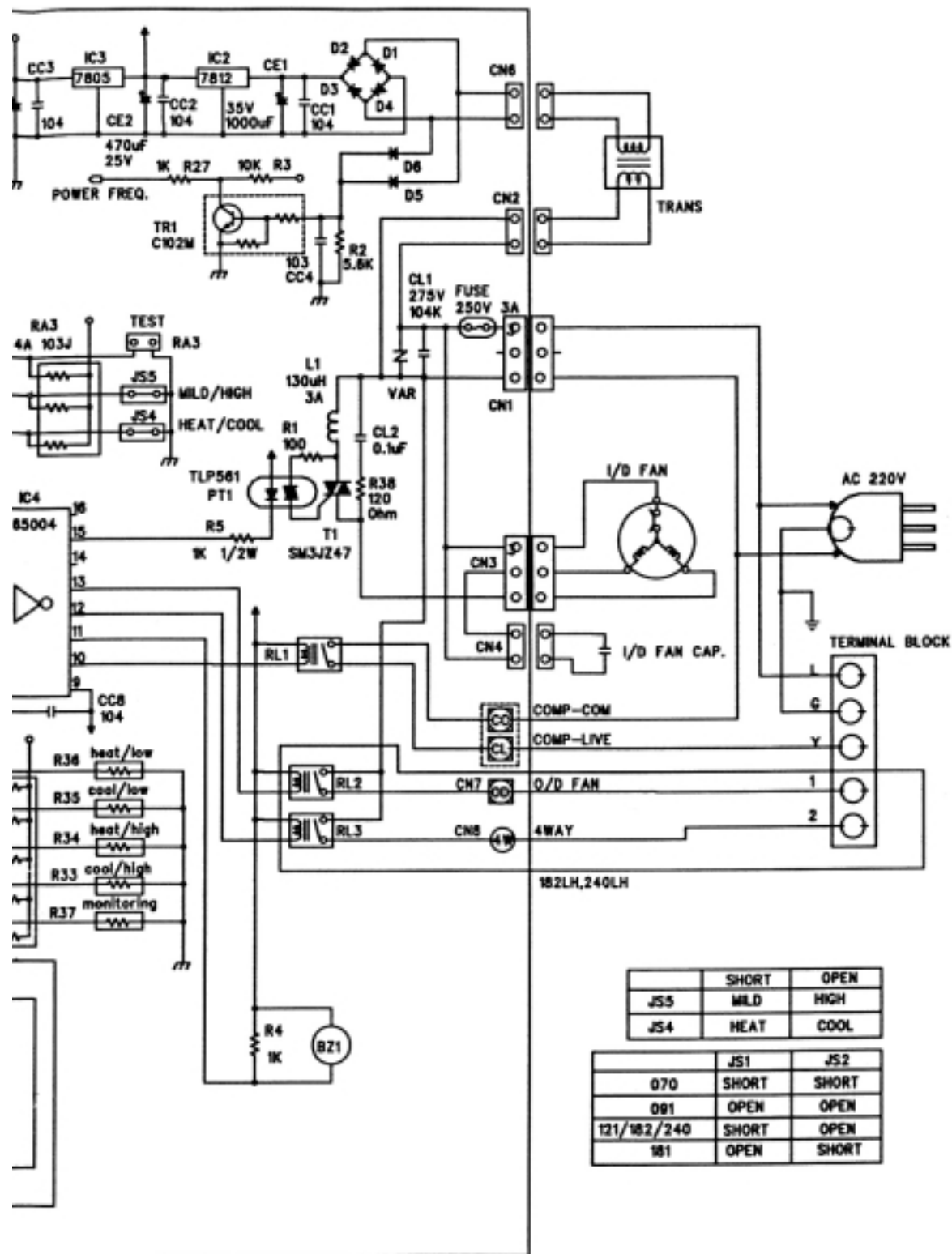

* DSB-121LH/DSB-122LH

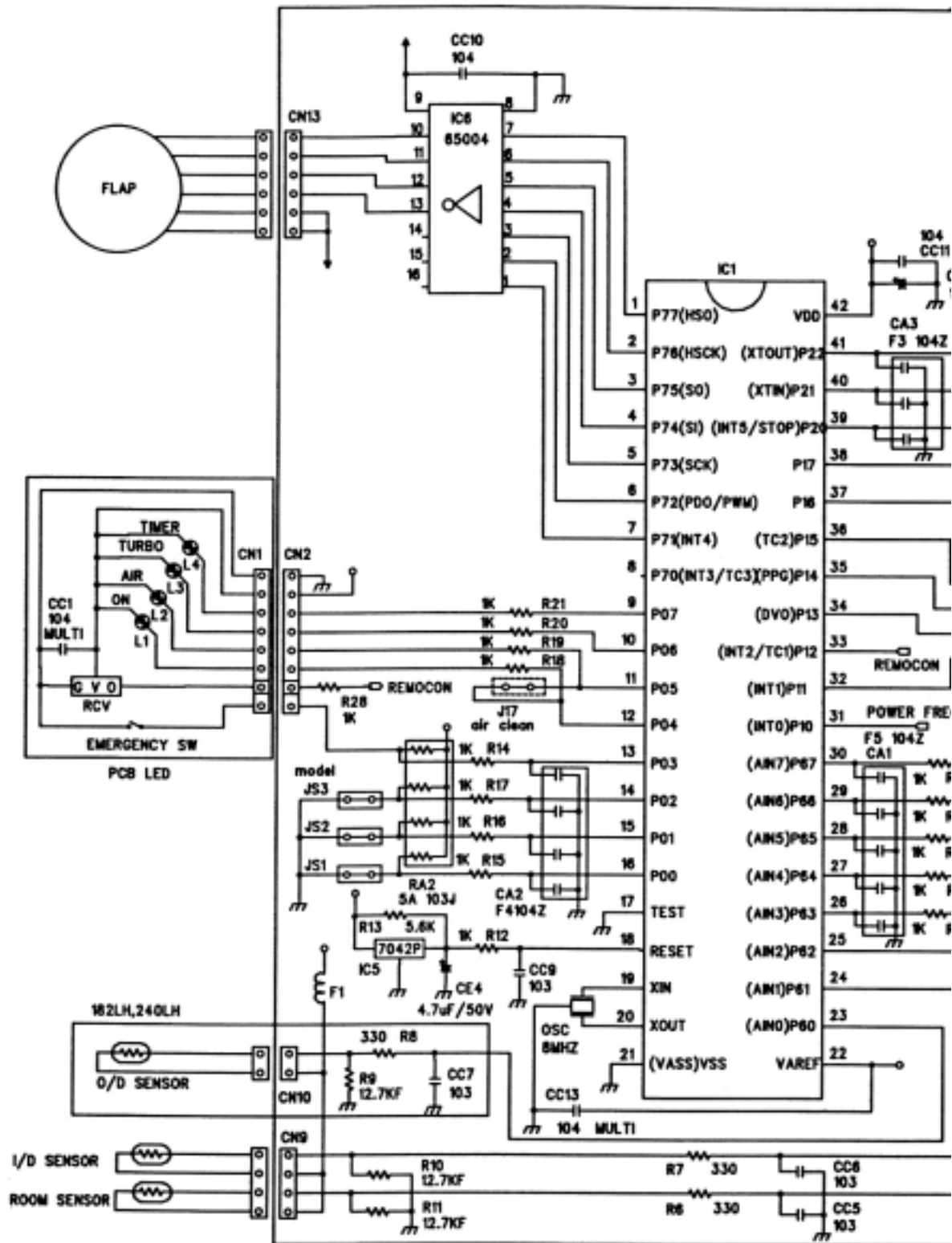

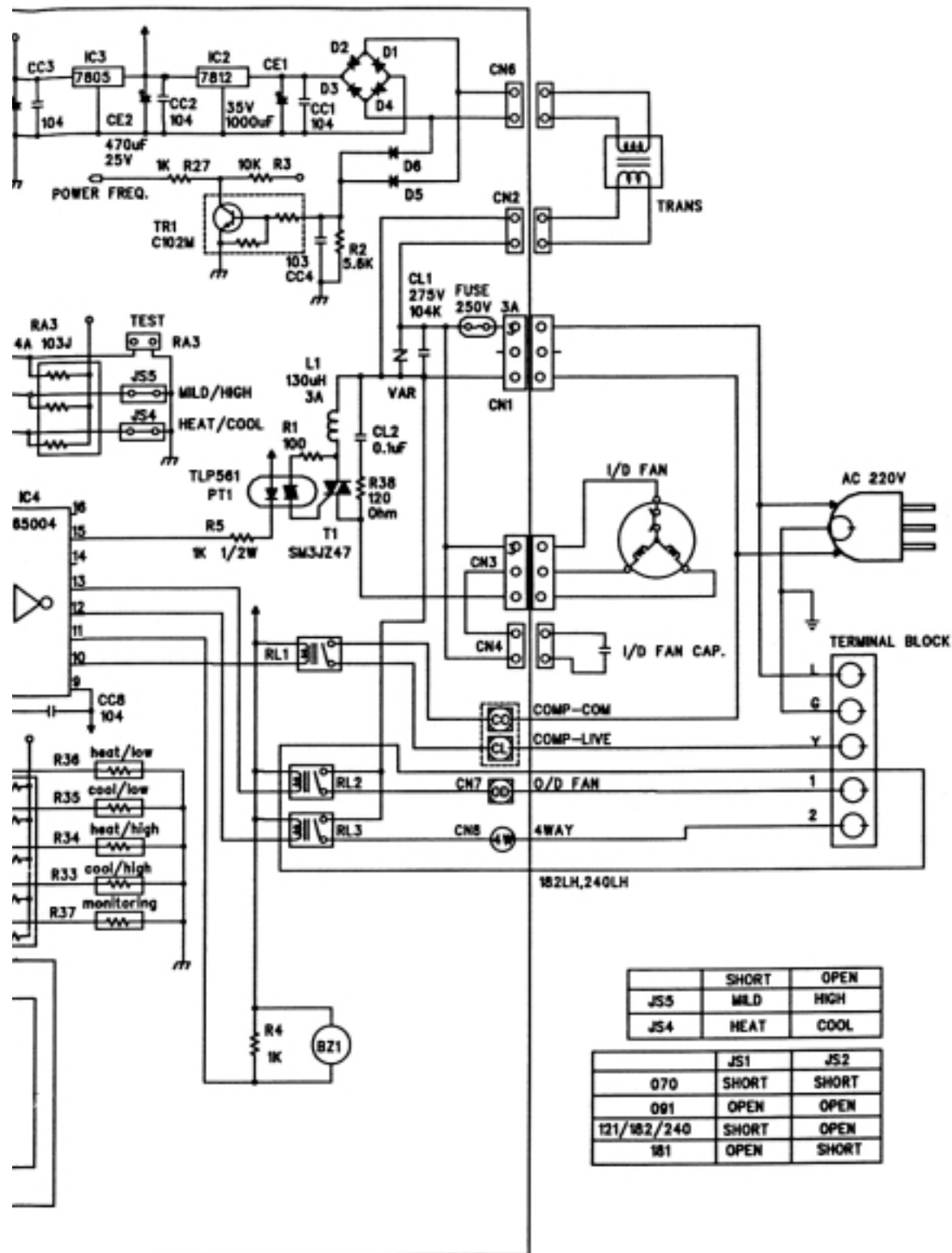

*** DSB-070LH/DSB-091LH/DSB-240LH PART LIST(INDOOR UNIT)**

No	PART CODE	PART NAME	SPEC	Q'TY	UNIT	REMARK
BZ1	3105698200	BUZZER	DP-2520BA	1	EA	
CA1	CN5XD104M-	C-ARRAY	F5 104Z	1	EA	
CA2	CN4XD104M-	C-ARRAY	F4 104Z	1	EA	
CA3	CN3XD104M-	C-ARRAY	F3 104Z	1	EA	
CC	3108803500	PIN	GP881206-2(250)	1	EA	
CC1	CCXE1E104M	C-CERA	104Z 25VDC	1	EA	
CC10	CCXE1E104M	C-CERA	104Z 25VDC	1	EA	
CC11	CCXE1E104M	C-CERA	104Z 25VDC	1	EA	
CC13	CDXE1H104M	C-MULTI	CR501B-Z5U,104Z,50V	1	EA	
CC2	CCXE1E104M	C-CERA	104Z 25VDC	1	EA	
CC3	CCXE1E104M	C-CERA	104Z 25VDC	1	EA	
CC4	CCXE1H103M	C-CERA	103Z 50VDC	1	EA	
CC5	CCXE1H103M	C-CERA	103Z 50VDC	1	EA	
CC6	CCXE1H103M	C-CERA	103Z 50VDC	1	EA	
CC7	CCXE1H103M	C-CERA	103Z 50VDC	1	EA	070LH,091LH,240LH
CC8	CCXE1E104M	C-CERA	104Z 25VDC	1	EA	
CC9	CCXE1H103M	C-CERA	103Z 50VDC	1	EA	
CE1	CEXE1V108C	C-ELEC	1000MF 35V SD	1	EA	
CE2	CEXE1E477C	C-ELEC	470MF 25V SD	1	EA	
CE3	CEXE1C107C	C-ELEC	100MF 16V SD	1	EA	070LH,091LH,240LH
CE4	CEXE1C475A	C-ELEC	4.7MF 50V SS	1	EA	
CE5	CEXE1C106A	C-ELEC	10MF 16V SS	1	EA	
CL	3108803500	PIN	GP881206-2(250)	1	EA	
CL1	CLV-B3104M	C-LINE ACROSS	275V 104K(PILKOR)	1	EA	
CL2	CLV-B3104M	C-LINE ACROSS	275V 104K(PILKOR)	1	EA	
CLIP	3107000600	FUSE CLIP	AFC-520	2	EA	
CN1	3108803900	WAFER	YW396-05AV(RE D)	1	EA	
CN10	3108801100	WAFER	5267-02A	1	EA	070LH,091LH,240LH
CN11	3108804000	WAFER	SMAW250-08	1	EA	
CN13	3108802000	WAFER	SMW250-06(WHITE)	1	EA	
CN2	3108803800	WAFER	YFW800-02	1	EA	
CN3	3108802900	WAFER	YW396-05AV	1	EA	
CN4	3108802500	WAFER	YW396-03AV	1	EA	
CN6	3108800320	WAFER	5281-02A	1	EA	
CN7	3108803400	PIN	GP881205-2(187)	1	EA	
CN8	3108803600	WAFER	YFW800-01	1	EA	
CN9	3108804500	WAFER	5267-04A	1	EA	
D1	DZN4004A--	DIODE	KN4004A AUTO 52MM	1	EA	
D2	DZN4004A--	DIODE	KN4004A AUTO 52MM	1	EA	
D3	DZN4004A--	DIODE	KN4004A AUTO 52MM	1	EA	
D4	DZN4004A--	DIODE	KN4004A AUTO 52MM	1	EA	
D5	DZN4004A--	DIODE	KN4004A AUTO 52MM	1	EA	
D6	DZN4004A--	DIODE	KN4004A AUTO 52MM	1	EA	
FUSE	5FVLB3152L	FUSE GLASS TUBE	250V/50T 3.15A	1	EA	
HS1	3105797200	HEAT SHINK	22(H)*23*17	1	EA	
IC1	13GS1H13--	IC MICOM	TMP87C846-1H13	1	EA	
IC2	1KA7812AP-	IC REGULATOR	KIA 7812AP	1	EA	
IC3	1KA7805AP-	IC REGULATOR	KIA 7805AP TO-220IS	1	EA	
IC4	1KD65004AP	IC DRIVER	KID65004AP	1	EA	

No	PART CODE	PART NAME	SPEC	Q'TY	UNIT	REMARK
IC5	1KA7042P--	IC RESET	KIA7042P 5L	1	EA	
IC6	1KD65004AP	IC DRIVER	KID65004AP	1	EA	
L1	52C1374001	COIL	130UH 3A	1	EA	
OSC	4850103610	RESONATOR	CST8.00MTW,8MHZ	1	EA	
PCB	3104398102	PCB CONTROL	160.5*140*1.6T.1(42)	1	EA	
PT1	1TLP560J--	IC PHOTO COUPLER	TLP 560J	1	EA	
R-OPT	3104810000	RESISTOR OPTION	NOTE OPTION TABLE	1	ST	
R1	RD-4K101J-	R CARBON FILM	1/4 100 OHM J	1	EA	
R10	RN-4K1272F	R METAL FILM	1/4 12.7K OHM F	1	EA	
R11	RN-4K1272F	R METAL FILM	1/4 12.7K OHM F	1	EA	
R12	RD-4K102J-	R CARBON FILM	1/4 1K OHM J	1	EA	
R13	RD-4K562J-	R CARBON FILM	1/4 5.6K OHM J	1	EA	
R14	RD-4K102J-	R CARBON FILM	1/4 1K OHM J	1	EA	
R15	RD-4K102J-	R CARBON FILM	1/4 1K OHM J	1	EA	
R16	RD-4K102J-	R CARBON FILM	1/4 1K OHM J	1	EA	
R17	RD-4K102J-	R CARBON FILM	1/4 1K OHM J	1	EA	
R18	RD-4K102J-	R CARBON FILM	1/4 1K OHM J	1	EA	
R19	RD-4K102J-	R CARBON FILM	1/4 1K OHM J	1	EA	
R2	RD-4K562J-	R CARBON FILM	1/4 5.6K OHM J	1	EA	
R20	RD-4K102J-	R CARBON FILM	1/4 1K OHM J	1	EA	
R21	RD-4K102J-	R CARBON FILM	1/4 1K OHM J	1	EA	
R23	RD-4K102J-	R CARBON FILM	1/4 1K OHM J	1	EA	
R24	RD-4K102J-	R CARBON FILM	1/4 1K OHM J	1	EA	
R25	RD-4K102J-	R CARBON FILM	1/4 1K OHM J	1	EA	
R26	RD-4K102J-	R CARBON FILM	1/4 1K OHM J	1	EA	
R27	RD-4K102J-	R CARBON FILM	1/4 1K OHM J	1	EA	
R28	RD-4K102J-	R CARBON FILM	1/4 1K OHM J	1	EA	
R29	RD-4K102J-	R CARBON FILM	1/4 1K OHM J	1	EA	
R3	RD-4K103J-	R CARBON FILM	1/4 10K OHM J	1	EA	
R30	RD-4K102J-	R CARBON FILM	1/4 1K OHM J	1	EA	
R31	RD-4K102J-	R CARBON FILM	1/4 1K OHM J	1	EA	
R32	RD-4K102J-	R CARBON FILM	1/4 1K OHM J	1	EA	
R38	RS01F121J-	R M-OXIDE FILM	1W 120 OHM J	1	EA	
R4	RD-4K102J-	R CARBON FILM	1/4 1K OHM J	1	EA	
R5	RD-2K102J-	RESISTOR	1/2W - 1K	1	EA	
R6	RD-4K331J-	R CARBON FILM	1/4 330 OHM J	1	EA	
R7	RD-4K331J-	R CARBON FILM	1/4 330 OHM J	1	EA	
R8	RD-4K331J-	R CARBON FILM	1/4 330 OHM J	1	EA	070LH,091LH,240LH
R9	RN-4K1272F	R METAL FILM	1/4 12.7K OHM F	1	EA	070LH,091LH,240LH
RA1	RA8K5103J-	RESISTOR ARRAY	6A 103J	1	EA	
RA2	RA8K4103J-	RESISTOR ARRAY	5A 103J	1	EA	
RA3	RA8K3103J-	RESISTOR ARRAY	4A 103J	1	EA	
RL1	5SC0101220	RELAY	UKH-12SP	1	EA	
RL1	5SC0101128	RELAY	CS11-12SH 1C 1P	1	EA	240L/LH
RL2	5SC0101128	SW RELAY	CS11-12SH 1C 1P	1	EA	
RL3	5SC0101128	SW RELAY	CS11-12SH 1C 1P	1	EA	
SCRW	7122401211	SCREW TAPPING	T2S TRS 4*12 MFZN	1	EA	
T1	TSM3JZ47--	TRIAC	SM3JZ47	1	EA	
TEST	3108804300	WAFER	YF254S-02	1	EA	
TR1	TKRC102M--	TR	KRC 102-M (TAPPING)	1	EA	
VAR	D15G561K--	VARISTOR	15G561K/350V	1	EA	
WSHR	3106002900	WASHER	3*6	1	EA	

* CONTROL PCB ASS`Y (MODEL : 082M/H,102M/H,122M/H,151L,122L/LH,181L/LH)

No	PART CODE	PART NAME	SPEC	Q'TY	UNIT	REMARK
CA1	CN4XD104M-	C-ARRAY	F4 104Z	1	EA	
CA2	CN3XD104M-	C-ARRAY	F3 104Z	1	EA	
CC1	CCXE1E104M	C-CERA	104Z 25VDC	1	EA	
CC10	CCXE1H103M	C-CERA	103Z 50VDC	1	EA	122LH,181LH
CC13	CDXE1H104M	C-MULTI	CR501B-Z5U,104Z,50V	1	EA	
CC2	CCXE1E104M	C-CERA	104Z 25VDC	1	EA	
CC3	CCXE1H103M	C-CERA	103Z 50VDC	1	EA	
CC4	CCXE1H103M	C-CERA	103Z 50VDC	1	EA	
CC5	CCXE1H103M	C-CERA	103Z 50VDC	1	EA	
CC6	CCXE1H103M	C-CERA	103Z 50VDC	1	EA	
CC7	CCXE1E104M	C-CERA	104Z 25VDC	1	EA	
CC8	CCXE1H103M	C-CERA	103Z 50VDC	1	EA	
CC9	CCXE1H103M	C-CERA	103Z 50VDC	1	EA	
CE1	CEXE1C475A	C-ELEC	4.7MF 50V SS	1	EA	
CE2	CEXE1C106A	C-ELEC	10MF 16V SS	1	EA	
CN1	3108802400	WAFER	SMAW250-10	1	EA	
CN2	3108804100	WAFER	SMW250-07	1	EA	
CN3	3108804200	WAFER	SMW250-02	1	EA	
CN4	3108802010	WAFER	SMW250-06(RED)	1	EA	181L/LH
CN5	3108802000	WAFER	SMW250-06(WHITE)	1	EA	
CN6	3108802000	WAFER	SMW250-06(WHITE)	1	EA	181L/LH
CN7	3108801100	WAFER	5267-02A	1	EA	122LH,181LH
CN8	3108804500	WAFER	5267-04A	1	EA	
D1	DZN4148FTB	DIODE	1N4148 AUTO 26MM	1	EA	181L/LH
F1	52F6010100	FILTER EMI	0.6*10*3TUTN	1	EA	181LH
IC1	13GS1H13--	IC MICOM	TMP87C846-1H13	1	EA	
IC2	1KA7042P--	IC RESET	KIA7042P 5L	1	EA	
IC3	1KD65004AP	IC DRIVER	KID65004AP	1	EA	
IC4	1KD65004AP	IC DRIVER	KID65004AP	1	EA	
OSC1	4850103610	RESONATOR	CST8.00MTW,8MHZ	1	EA	
PCB	3104397162	PCB CONTROL	110*90.5*1.6T(99)	1	EA	
R-OPT	3104810000	RESISTOR OPTION	NOTE OPTION TABLE	1	ST	
R1	RD-4K103J-	R CARBON FILM	1/4 10K OHM J	1	EA	
R10	RD-4K562J-	R CARBON FILM	1/4 5.6K OHM J	1	EA	
R11	RD-4K102J-	R CARBON FILM	1/4 1K OHM J	1	EA	
R12	RD-4K102J-	R CARBON FILM	1/4 1K OHM J	1	EA	
R13	RD-4K102J-	R CARBON FILM	1/4 1K OHM J	1	EA	
R14	RD-4K102J-	R CARBON FILM	1/4 1K OHM J	1	EA	
R16	RD-4K103J-	R CARBON FILM	1/4 10K OHM J	1	EA	
R17	RD-4K103J-	R CARBON FILM	1/4 10K OHM J	1	EA	181L/LH
R18	RN-4K1272F	R METAL FILM	1/4 12.7K OHM F	1	EA	
R19	RD-4K331J-	R CARBON FILM	1/4 330 OHM J	1	EA	

No	PART CODE	PART NAME	SPEC	Q'TY	UNIT	REMARK
R2	RD-4K103J-	R CARBON FILM	1/4 10K OHM J	1	EA	
R20	RN-4K1272F	R METAL FILM	1/4 12.7K OHM F	1	EA	
R21	RD-4K331J-	R CARBON FILM	1/4 330 OHM J	1	EA	
R22	RN-4K1272F	R METAL FILM	1/4 12.7K OHM F	1	EA	122LH,181LH
R23	RD-4K331J-	R CARBON FILM	1/4 330 OHM J	1	EA	122LH,181LH
R26	RD-4K102J-	R CARBON FILM	1/4 1K OHM J	1	EA	
R3	RD-4K102J-	R CARBON FILM	1/4 1K OHM J	1	EA	
R32	RD-4K102J-	R CARBON FILM	1/4 1K OHM J	1	EA	
R33	RD-4K102J-	R CARBON FILM	1/4 1K OHM J	1	EA	
R34	RD-4K102J-	R CARBON FILM	1/4 1K OHM J	1	EA	
R4	RD-4K102J-	R CARBON FILM	1/4 1K OHM J	1	EA	
R5	RD-4K102J-	R CARBON FILM	1/4 1K OHM J	1	EA	
R6	RD-4K102J-	R CARBON FILM	1/4 1K OHM J	1	EA	
R7	RD-4K102J-	R CARBON FILM	1/4 1K OHM J	1	EA	
R8	RD-4K102J-	R CARBON FILM	1/4 1K OHM J	1	EA	
R9	RD-4K102J-	R CARBON FILM	1/4 1K OHM J	1	EA	
RA1	RA8K5103J-	RESISTOR ARRAY	6A 103J	1	EA	
RA2	RA8K3103J-	RESISTOR ARRAY	4A 103J	1	EA	
TEST	3108804300	WAFER	YF254S-02	1	EA	
TR1	TZTC3198Y-	TRANSISTOR	KTC3198Y-(1815Y)	1	EA	181L/LH
TR2	TKRC102M--	TR	KRC 102-M (TAPPING)	1	EA	181L/LH

*** R-OPT. DETAIL LIST**

MODEL	High		Low		Monitoring
	Cool	Heat	Cool	Heat	
LOCATION	R28	R29	R30	R31	R27
DSB-121L	2.87K	X	28.0K	X	X
DSB-122LH	2.87K	2.87K	28.0K	28.0K	24.3K
DSB-181L, (151L)	3.65K	X	22.6K	X	X
DSB-181LH	3.65K	3.65K	22.6K	22.6K	22.1K
LOCATION	R33	R34	R35	R36	R37
DSB-070L, 091L	3.24K	X	24.9K	X	X
DSB-070LH	3.24K	49.9K	24.9K	32.4K	24.3K
DSB-091LH	3.24K	12.4K	24.9K	15.0K	24.3K
DSB-240L	3.76K	X	36.5K	X	X
DSA-240L	6.34K	X	7.68K	X	X
DSB-240LH	5.76K	5.76K	36.5K	36.5K	22.1K
DSA-240LH	(6.34K)	(6.34K)	(7.68K)	(7.68K)	(6.19K)

* POWER PCB ASS'Y (MODEL : 122L/LH,151L,181L/LH,082M/H,102M/H,122M/H)

No	PART CODE	PART NAME	SPEC	Q'TY	UNIT	REMARK
BZ1	3105698200	BUZZER	DP-2520BA	1	EA	
C1	CLV-B3104M	C-LINE ACROSS	275V 104K(PILKOR)	1	EA	
C2	CLV-B3104M	C-LINE ACROSS	275V 104K(PILKOR)	1	EA	
CC	3108803500	PIN	GP881206-2(250)	1	EA	
CC1	CCXE1E104M	C-CERA	104Z 25VDC	1	EA	
CC2	CCXE1E104M	C-CERA	104Z 25VDC	1	EA	
CC3	CCXE1E104M	C-CERA	104Z 25VDC	1	EA	
CC4	CCXE1H103M	C-CERA	103Z 50VDC	1	EA	
CE1	CEXE1V108C	C-ELEC	1000MF 35V SD	1	EA	
CE2	CEXE1E477C	C-ELEC	470MF 25V SD	1	EA	
CE3	CEXE1C107C	C-ELEC	100MF 16V SD	1	EA	
CL	3108803500	PIN	GP881206-2(250)	1	EA	
CLIP	3107000600	FUSE CLIP	AFC-520	2	EA	
CN1	3108803900	WAFER	YW396-05AV(RE D)	1	EA	
CN2	3108803800	WAFER	YFW800-02	1	EA	
CN3	3108802900	WAFER	YW396-05AV	1	EA	
CN4	3108802500	WAFER	YW396-03AV	1	EA	
CN5	3108802800	WAFER	YW396-04AV(BLUE)	1	EA	082H,102H,122H
CN6	3108802100	WAFER	SMW250-10	1	EA	
CN7	3108800320	WAFER	5281-02A	1	EA	
CN8	3108803400	PIN	GP881205-2(187)	1	EA	122LH,181LH
CN9	3108803600	WAFER	YFW800-01	1	EA	122LH,181LH
D1	DZN4004A--	DIODE	KN4004A AUTO 52MM	1	EA	
D2	DZN4004A--	DIODE	KN4004A AUTO 52MM	1	EA	
D3	DZN4004A--	DIODE	KN4004A AUTO 52MM	1	EA	
D4	DZN4004A--	DIODE	KN4004A AUTO 52MM	1	EA	
D5	DZN4004A--	DIODE	KN4004A AUTO 52MM	1	EA	
D6	DZN4004A--	DIODE	KN4004A AUTO 52MM	1	EA	
FUSE	5FVLB3152L	FUSE GLASS TUBE	250V/50T 3.15A	1	EA	
HS1	3105797200	HEAT SHINK	22(H)*23*17	1	EA	
IC1	1KA7812AP-	IC REGULATOR	KIA 7812AP	1	EA	
IC2	1KA7805AP-	IC REGULATOR	KIA 7805AP TO-220IS	1	EA	
L1	52C1374001	COIL	130UH 3A	1	EA	
PCB	3104396142	PCB POWER	130*81*1.6T(84)	1	EA	
PT1	1TLP560J--	IC PHOTO COUPLER	TLP 560J	1	EA	
R1	RD-4K102J-	R CARBON FILM	1/4 1K OHM J	1	EA	
R2	RD-4K103J-	R CARBON FILM	1/4 10K OHM J	1	EA	
R3	RD-4K562J-	R CARBON FILM	1/4 5.6K OHM J	1	EA	
R4	RD-2K102J-	RESISTOR	1/2W - 1K	1	EA	
R5	RD-4K101J-	R CARBON FILM	1/4 100 OHM J	1	EA	
R6	RD-4K102J-	R CARBON FILM	1/4 1K OHM J	1	EA	
R7	RS01F121J-	R M-OXIDE FILM	1W 120 OHM J	1	EA	
RL1	5SC0101220	RELAY	UKH-12SP	1	EA	122L/LH,082M/H
RL1	5SC0101220	SW RELAY	CS11-12SH 1C 1P	1	EA	
RL2	5SC0101128	SW RELAY	CS11-12SH 1C 1P	1	EA	122LH,181LH
RL3	5SC0101128	SW RELAY	CS11-12SH 1C 1P	1	EA	122LH,181LH
RL4	5SC0101128	SW RELAY	CS11-12SH 1C 1P	1	EA	082H,102H,122H
SCRW	7122401211	SCREW TAPPING	T2S TRS 4*12 MFZN	1	EA	
T1	TSM3JZ47--	TRIAC	SM3JZ47	1	EA	
TR1	TKRC102M--	TR	KRC 102-M (TAPPING)	1	EA	
VAR	D15G561K--	VARISTOR	15G561K/350V	1	EA	
WSHR	3106002900	WASHER	3*6	1	EA	

*** LED PCB ASS`Y (MODEL : 070L/LH,091L/LH,052M/H)**

No	PART CODE	PART NAME	SPEC	Q'TY	UNIT	REMARK
CC1	CDXE1H104M	C-MULTI	CR501B-Z5U,104Z,50V	1	EA	
CN1	3108804800	WAFER	SMAW250-08	1	EA	
HOLD	3103002700	HOLDER LED	ABS	1	EA	
L1	DDLS05031D	LED	DLSO-5031D(RE D)	1	EA	
L2	DDL G05031D	LED	DLG-5031D(GRN)	1	EA	
L3	DDLS05031D	LED	DLSO-5031D(RE D)	1	EA	
L4	DDLY05031D	LED	DLY-5031D(YLW)	1	EA	
PCB	3104398201	PCB LED	110*31*1.6T.10(288)	1	EA	
RCV	1TSP1838YA	RECEIVER MODULE	TSOP-1838YA1(HOLDER)	1	EA	
SW1	5S40202000	S/W PUSH	JPS2281	1	EA	

*** LED PCB ASS`Y (MODEL : 240L/LH)**

No	PART CODE	PART NAME	SPEC	Q'TY	UNIT	REMARK
CC1	CDXE1H104M	C-MULTI	CR501B-Z5U,104Z,50V	1	EA	
CN1	3108804800	WAFER	SMAW250-08	1	EA	
HOLD	3103004100	HOLDER LED	DSB-240L/LH	1	EA	
L1	DDLS05031D	LED	DLSO-5031D(RE D)	1	EA	
L2	DDL G05031D	LED	DLG-5031D(GRN)	1	EA	
L3	DDLS05031D	LED	DLSO-5031D(RE D)	1	EA	
L4	DDLY05031D	LED	DLY-5031D(YLW)	1	EA	
PCB	3104398202	PCB LED	150*24.5*1.6T(240)	1	EA	
RCV	1TSP1838YA	RECEIVER MODULE	TSOP-1838YA1(HOLDER)	1	EA	
SW1	5S40202000	S/W PUSH	JPS2281	1	EA	

*** LED PCB ASS`Y (MODEL : 122L/LH,080M/H)**

No	PART CODE	PART NAME	SPEC	Q'TY	UNIT	REMARK
CC1	CXCH1H103M	C CERA	103J/50 20%	1	EA	
CN1	3108804600	WAFER	SMAW250-07	1	EA	
HOLD	3103001900	LED HOLDER	ABS(VO) T2.0	1	EA	
L1	DDSR302D--	LED	DLSR-302D(RE D)	1	EA	
L2	DDL G302D--	LED	DLG-302D	1	EA	
L3	DDSR302D--	LED	DLSR-302D(RE D)	1	EA	
L4	DDLY302D--	LED	DLY-302D	1	EA	
PCB	3104397402	LED PCB	72*50*1.6T(247)	1	EA	
RCV	1TSP1838YA	RECEIVER MODULE	TSOP-1838YA1(HOLDER)	1	EA	

*** LED PCB ASS`Y (MODEL : 181L/LH,151L/LH,102M/H,122M/H)**

No	PART CODE	PART NAME	SPEC	Q'TY	UNIT	REMARK
CC1	CXCH1H103M	C CERA	103J/50 20%	1	EA	
CN1	3108804600	WAFER	SMAW250-07	1	EA	
HOLD	3103001100	LED HOLDER	ABS (BLK)	1	EA	
L1	DDSR302D--	LED	DLSR-302D(RE D)	1	EA	
L2	DDL G302D--	LED	DLG-302D	1	EA	
L3	DDSR302D--	LED	DLSR-302D(RE D)	1	EA	
L4	DDLY302D--	LED	DLY-302D	1	EA	
PCB	3104395412	LED PCB	67.5*40*1.6T(350)	1	EA	
RCV	1TSP1838YA	RECEIVER MODULE	TSOP-1838YA1(HOLDER)	1	EA	

*** SWITCH PCB ASS`Y (MODEL : 181L/LH, 151L,102M/H,122M/H)**

No	PART CODE	PART NAME	SPEC	Q'TY	UNIT	REMARK
CN1	3108804700	WAFER	SMAW250-02	1	EA	
PCB	3104395311	SW PCB	36*29.5*1.6T(891)	1	EA	
SW1	5S30101330	SWITCH SLIDE	KSA-2340B	1	EA	

Power Supply(1)

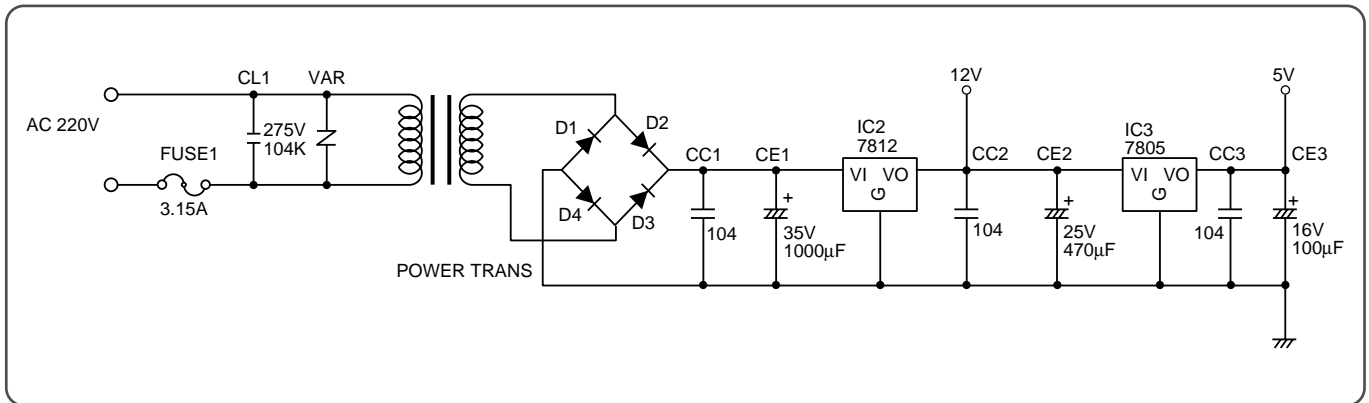

DESCRIPTION

DC Power Supply in circuit needs +12V and +5V. +12V is used for Compressor Driving Relay, Triac Driving Photo Triac, Buzzer Driving Swing, Sweep Motor. AC voltage of secondary Power Transformer is rectified by Bridge Diode, and it is filtering by Main Condensor CE1.

Filtered DC voltage is about +18V, is regulated +12V DC by Regulator IC7812.

And it is regulated +5V DC by Regulator IC7805.

VAR is surge filter and CC1, CC2, CC3 is Noise filter.

Oscillator(2)

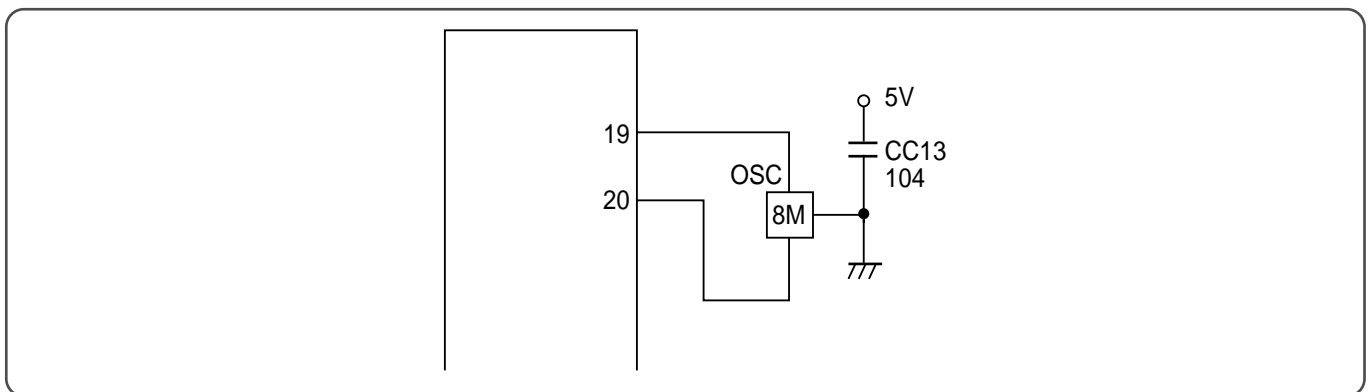

DESCRIPTION

Oscillatory Frequency drive Micom, it is made up 8MHz resonator oscillatory Frequency.

Oscillatory wave is as following Fig 2-1.

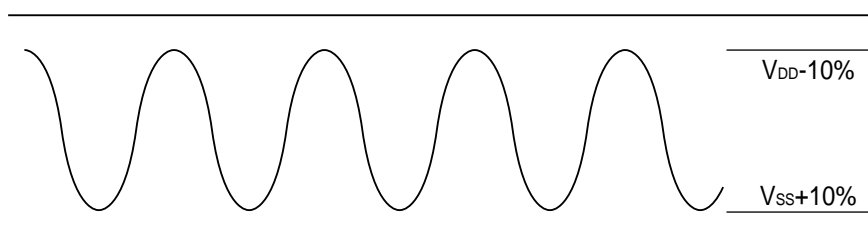
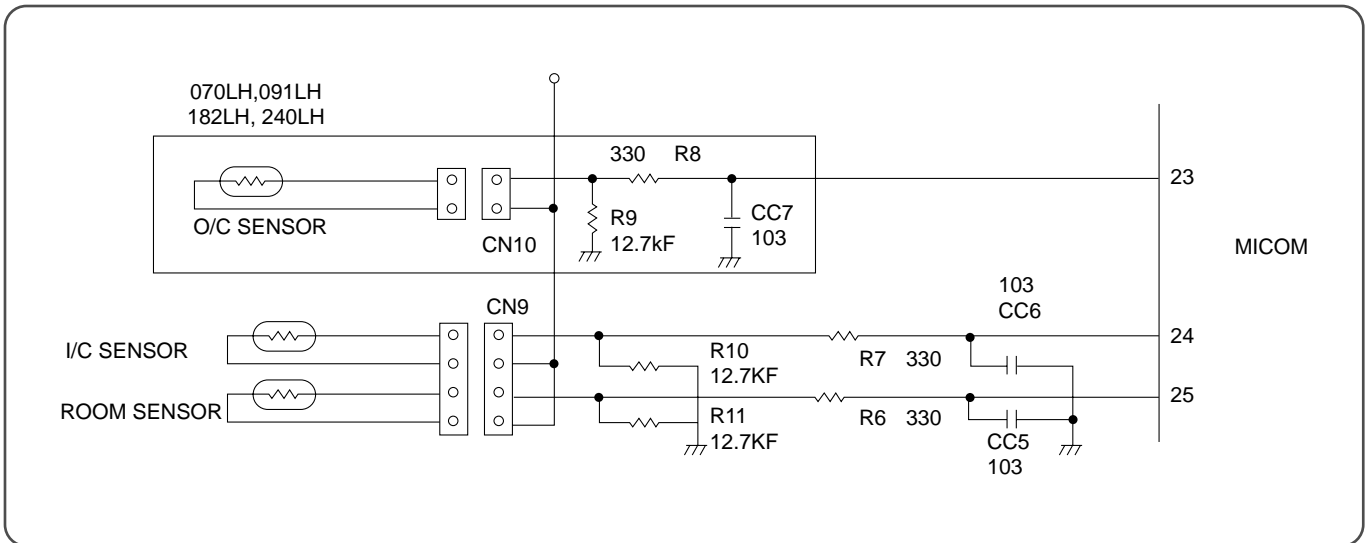

Fig 2-1

Sensor(3)

Room temperature and Evaporator temperature Sensor Input



DESCRIPTION

Number 24, 25 of Micom is Terminal of A/D convertor Input.

Room temperature and Evaporator temperature is sensing by change of Thermister Resistance, Micom is put in 5V by ratio between R10 (12.7K Ω) and R11 (12.7K Ω).

Relation between temperature and voltage is following Table 3-1.

CC5, 6 is Noise filter.

Temperature (°C)	Voltage (V)	
	No. 1	No. 3
-5	1.127	1.127
0	1.378	1.378
5	1.650	1.650
10	1.936	1.936
15	2.228	2.228

Table 3-1

Triac Driving(4)

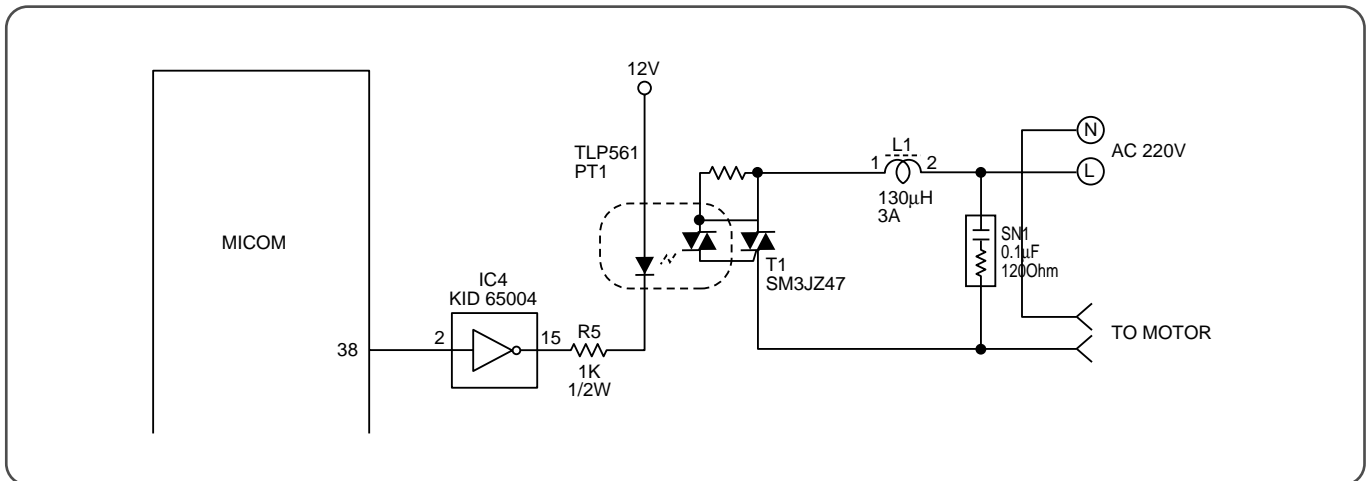

DESCRIPTION

Number 38 Terminal of Micom is put out Pulse Output, by way of Buffer it is driving Photo Triac is supplied Trigger Signal.

Trigger Test of Triac is detected Zero Cross Part of AC input and it is triggered from Zero Cross part to Time delay part according to Fan Speed. (Ref. Fig 4-1) SN1 is Snubber.

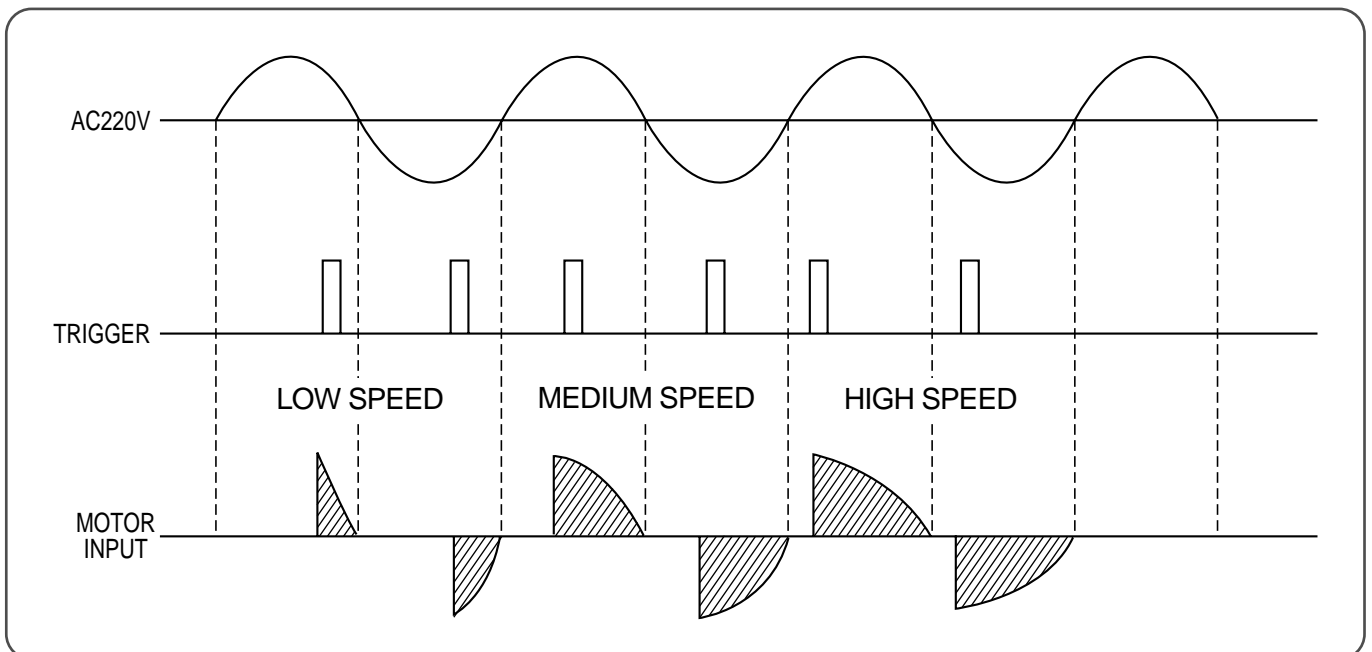

Fig 4-1

Remote Controller(5)

DESCRIPTION

Signal from Remote Controller put in only Control Data Signal at Micom Terminal of Number 33, which is gotten from Carrier (38KHz) from Receive Module. Signal Wave repeat third as following Fig 5-1. But in Secondary Wave Custom Code is Reversed Face.

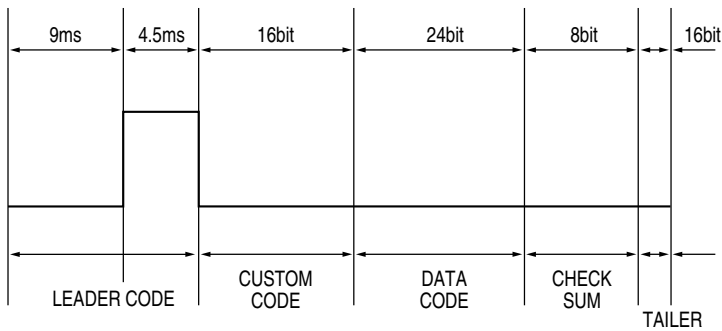

Fig 5-1

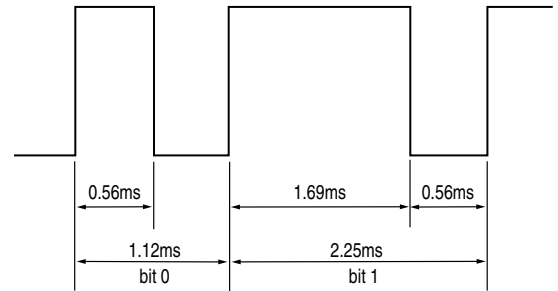
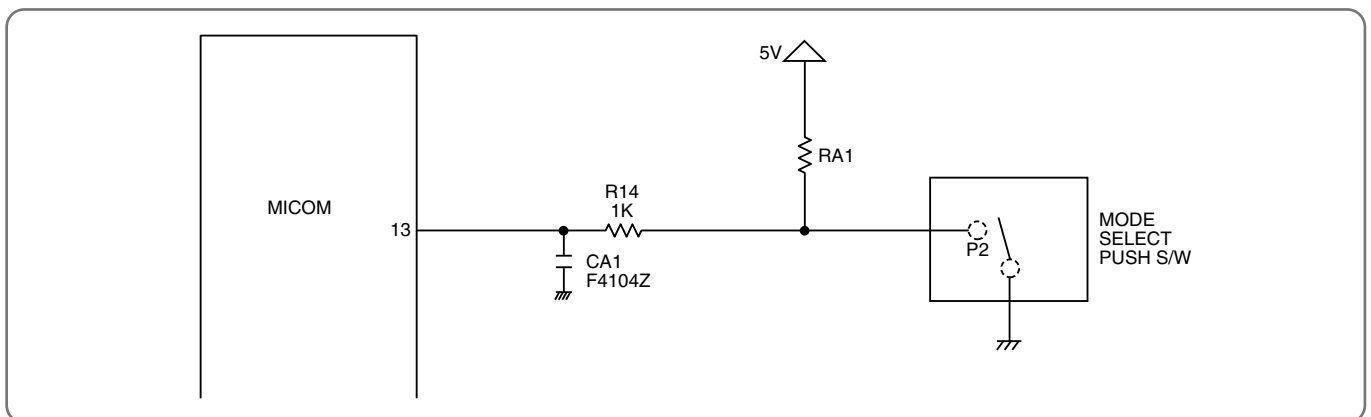

Fig 5-2
BIT STRUCTURE

Selecting Mode(6)

(SELECT S/W INPUT, OUTPUT)



DESCRIPTION

There are Mode according to SW position as following Table 6-1.

According as port of fixed Micom is Low, the unit is operating as following Table 6-1.

POSITION	MODE
OPEN	REMOCON
GND	EMERGENCY

Table 6-1

Micom Power Supply(7)

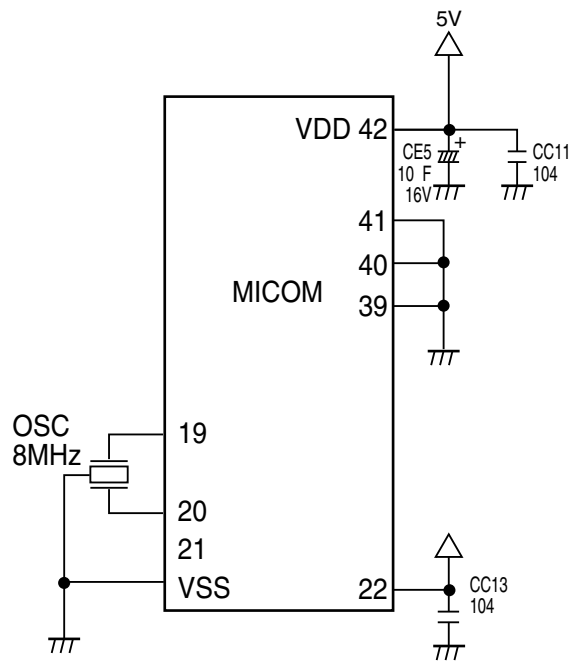

DESCRIPTION

MICOM Power is supplied 5V at Number 42 using VDD, Number 19, 20 V using Oscillator, CC13 is noise filter.

Reset(8)

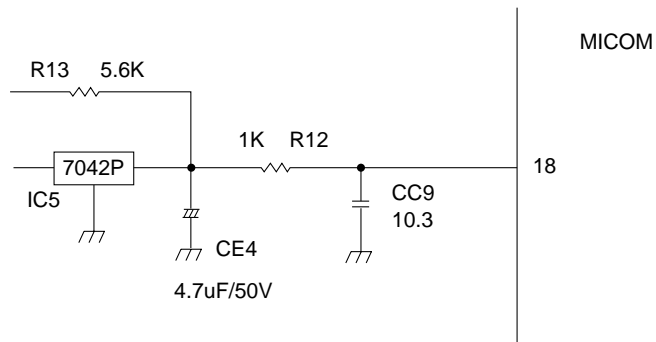

DESCRIPTION

Voltage less than about 0.8V put in Micromicro Terminal of Number 18 and then Micromicro reset. Reset IC detect Power ON and Voltage less than 4.25V, and then send Reset Signal.

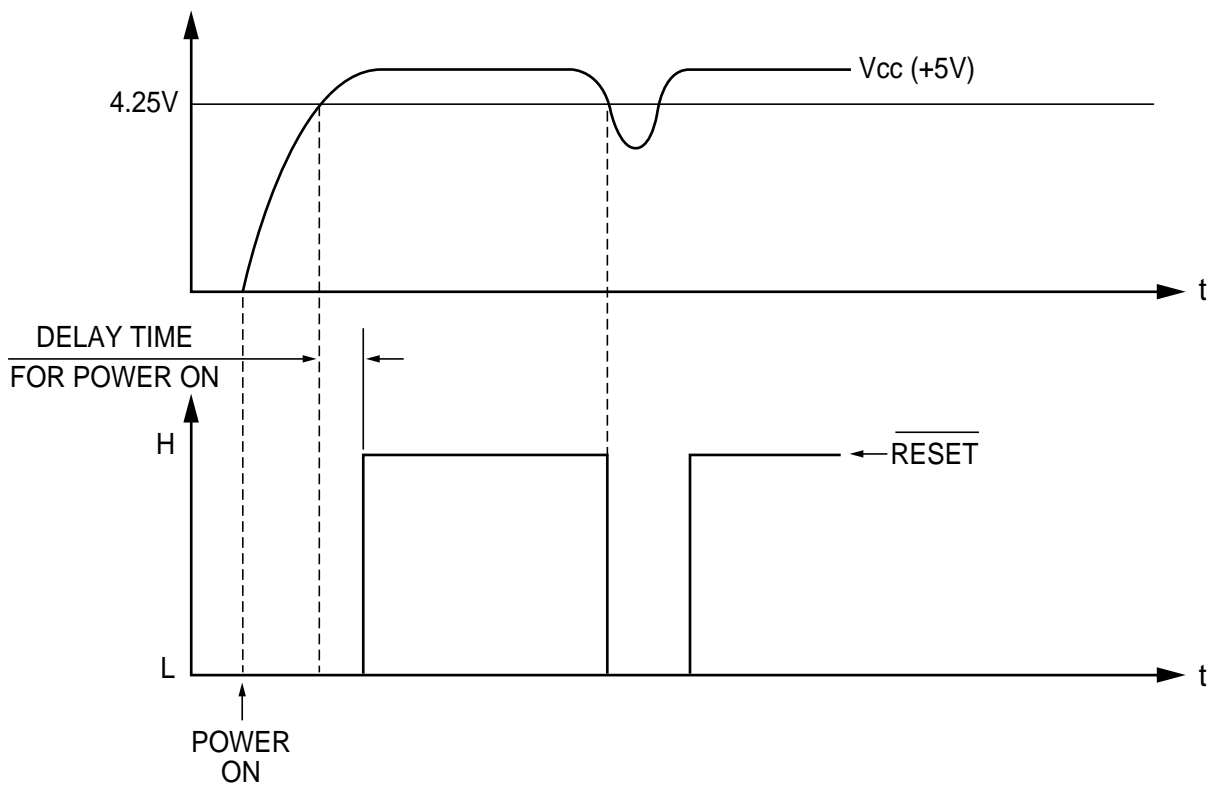

Function Selecting(9)

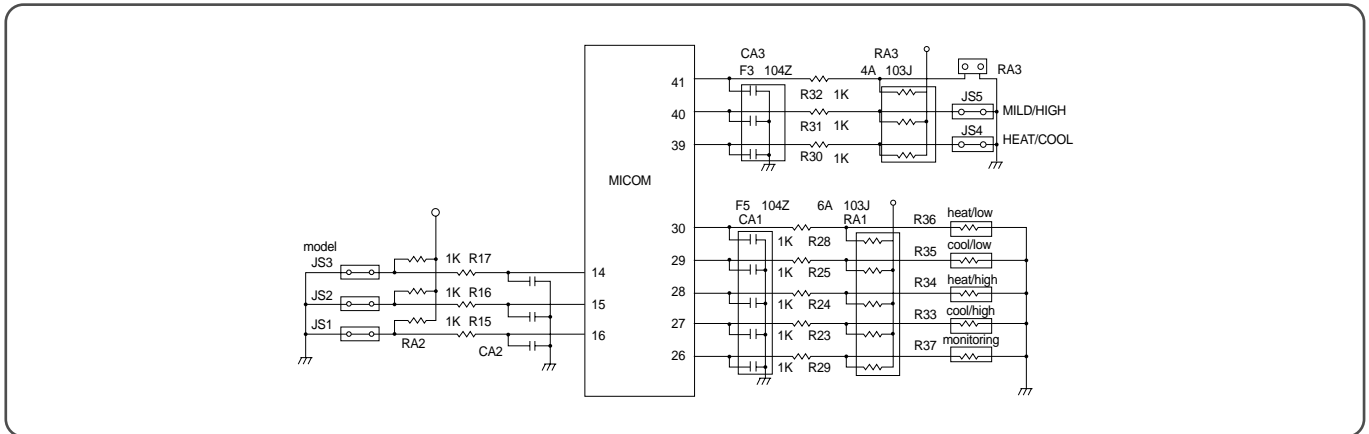

DESCRIPTION

Selecting function is as following table 9-1.

* When power source is put at first, Function selection input is recognized.

And when the unit is running the microcomputer ignore variation of function selection input.

		JS1	JS2	JS4	JS5
FAN	MILD	—	—	—	SHORT
	HIGH	—	—	—	OPEN
FUNCTION	HEAT	—	—	SHORT	—
	COOL	—	—	OPEN	—
MODEL	070	SHORT	SHORT	—	—
	091	OPEN	OPEN	—	—
	122/240	SHORT	OPEN	—	—
	181	OPEN	SHORT	—	—

Buzzer Driving(10)

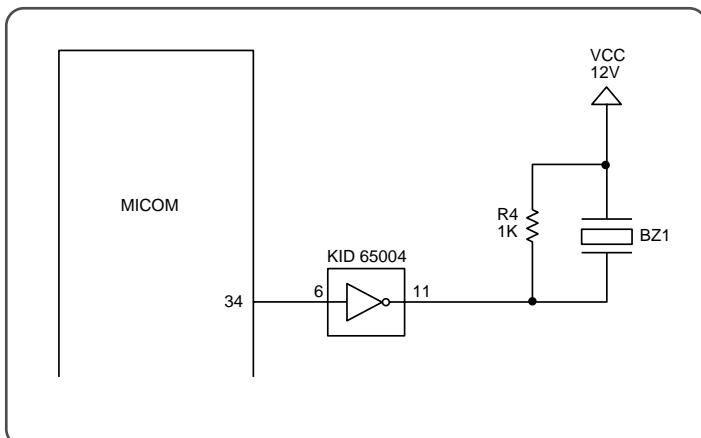

DESCRIPTION

Micom 34 Terminal put out Buzzer Driving Pulse, its output is driving Buzzer through Buffer.

Oscillatory Frequency of buzzer is selected by internal Micom.

This unit is setting at 4KHz.

Zero Crossing Detect(11)

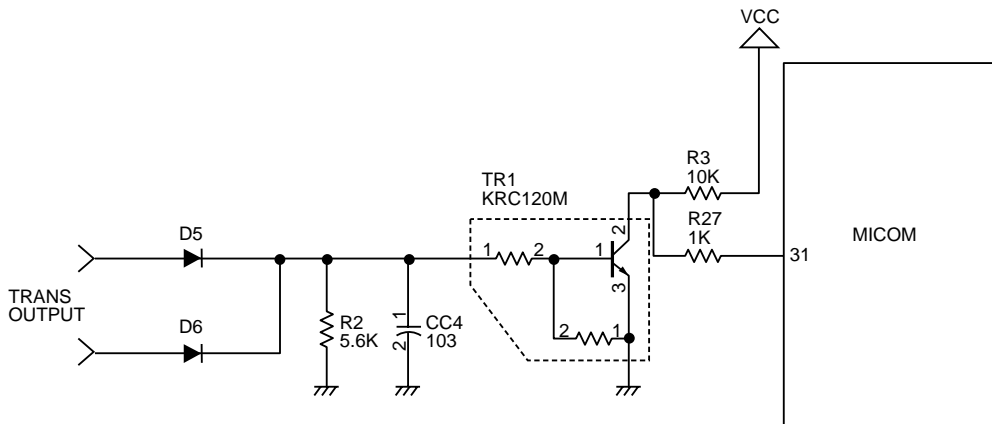

DESCRIPTION

It detect Zero Cross part of Trans output voltage, Transistor TR1 is used to put in the Micom.
 Detail Driving is as following Fig 11-1.
 R19 is Resistance to limit current.

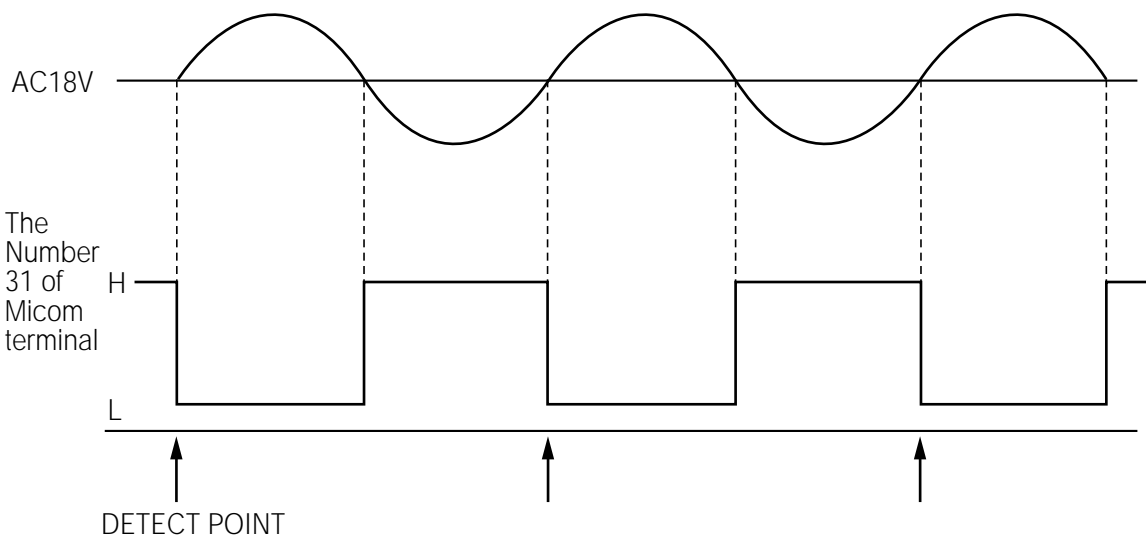
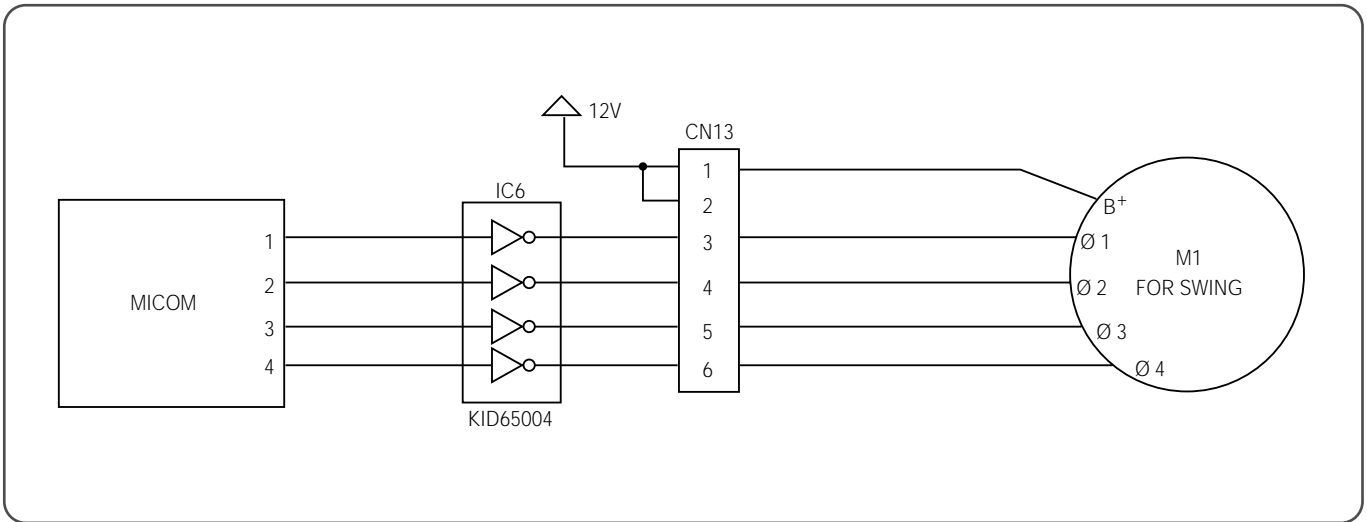

Fig 11-1

Stepping Motor Driving(12)



DESCRIPTION

There are one Stepping Motor for Flap (up and down) and it is used 4 face Drive Method. It is driving as following Fig 12-1. (Ring Count Method of 8 Status)

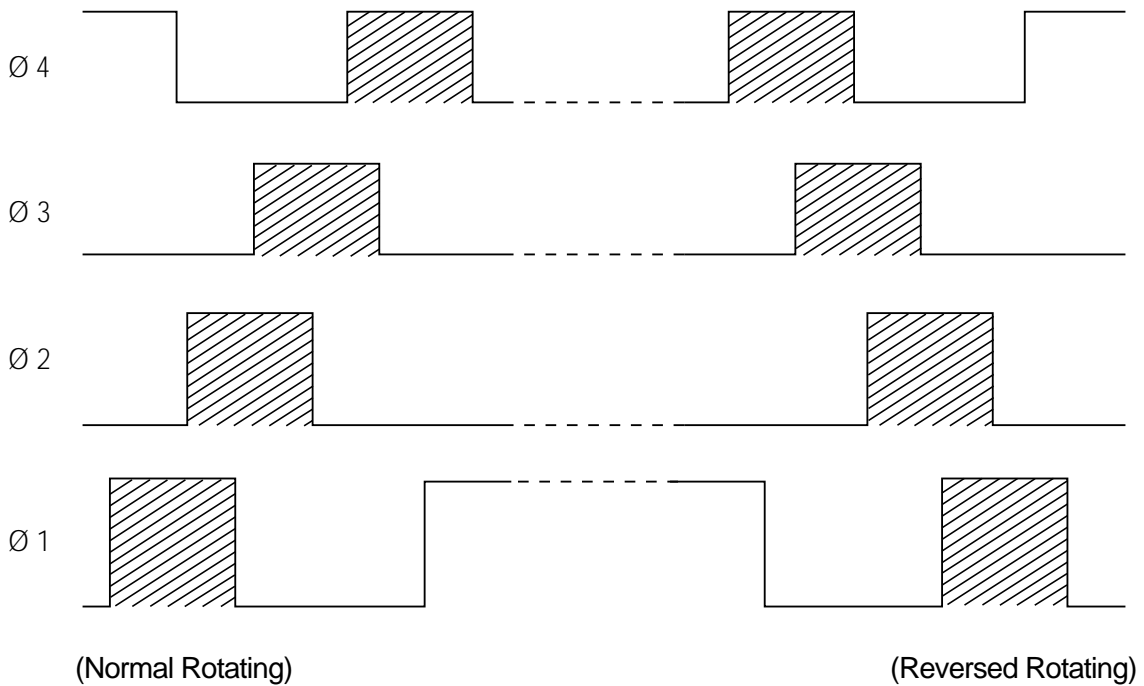
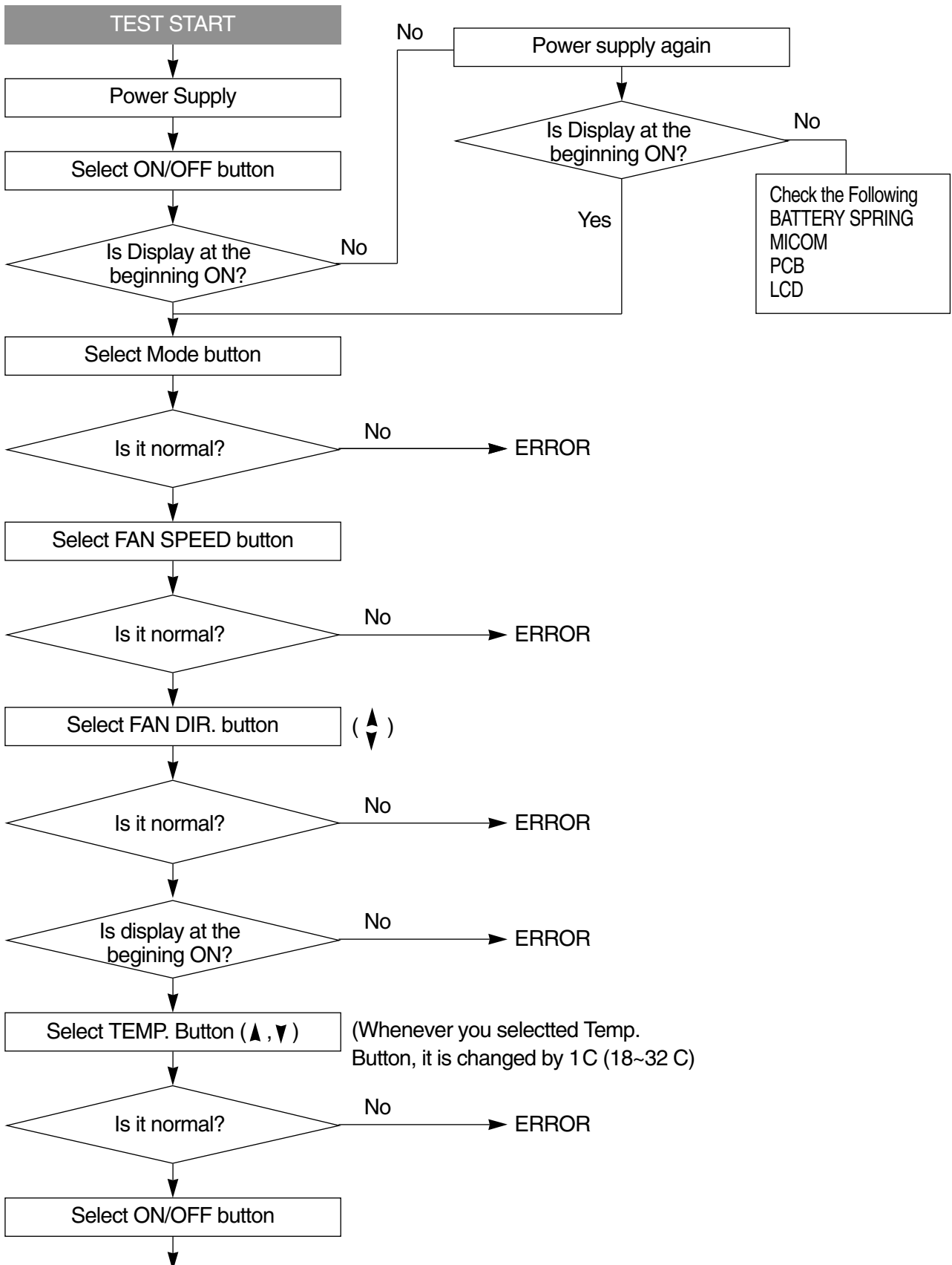
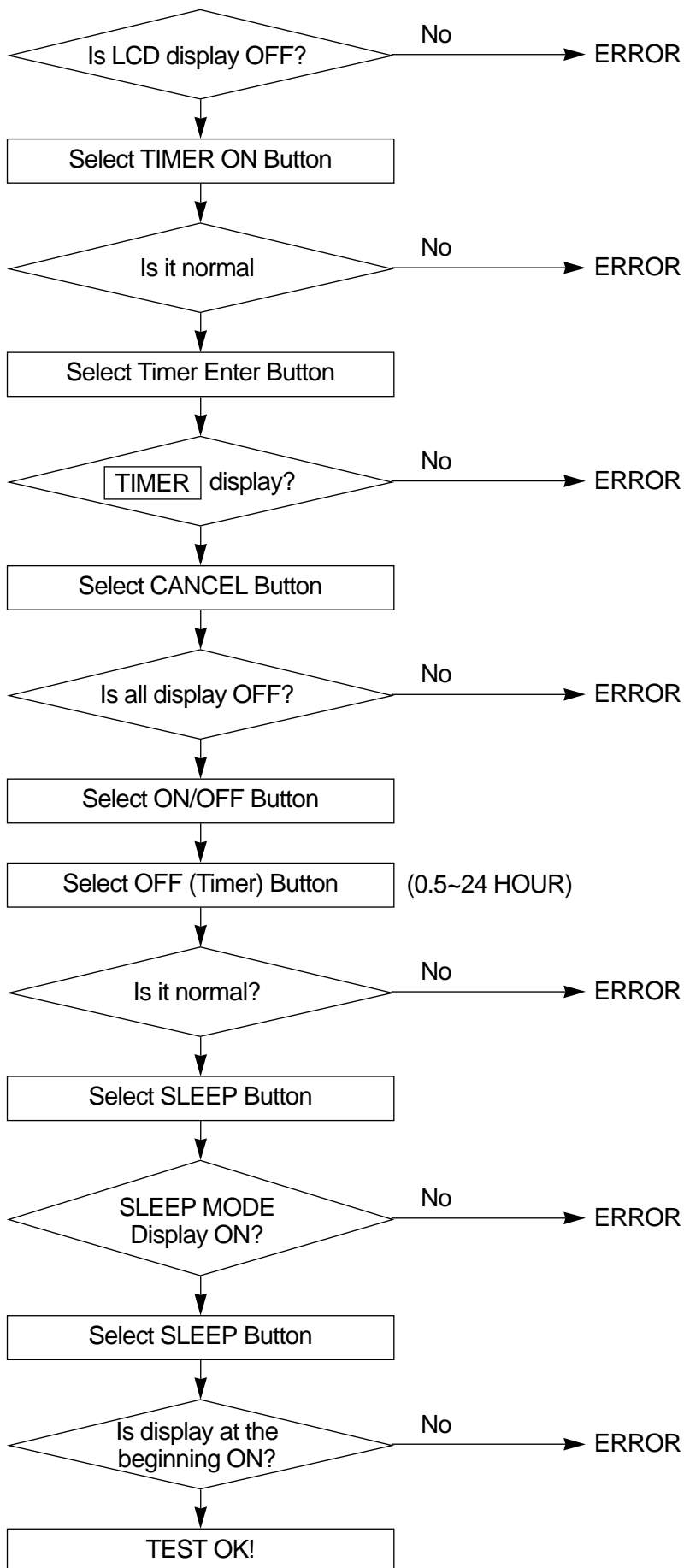

Fig 12-1

2 REMOTE CONTROLLER ASSMBLY FUNCTIONAL TEST METHOD





9. KEY COMPONENTS OF ELECTRONIC CIRCUIT

(1) U1 (MICOM)

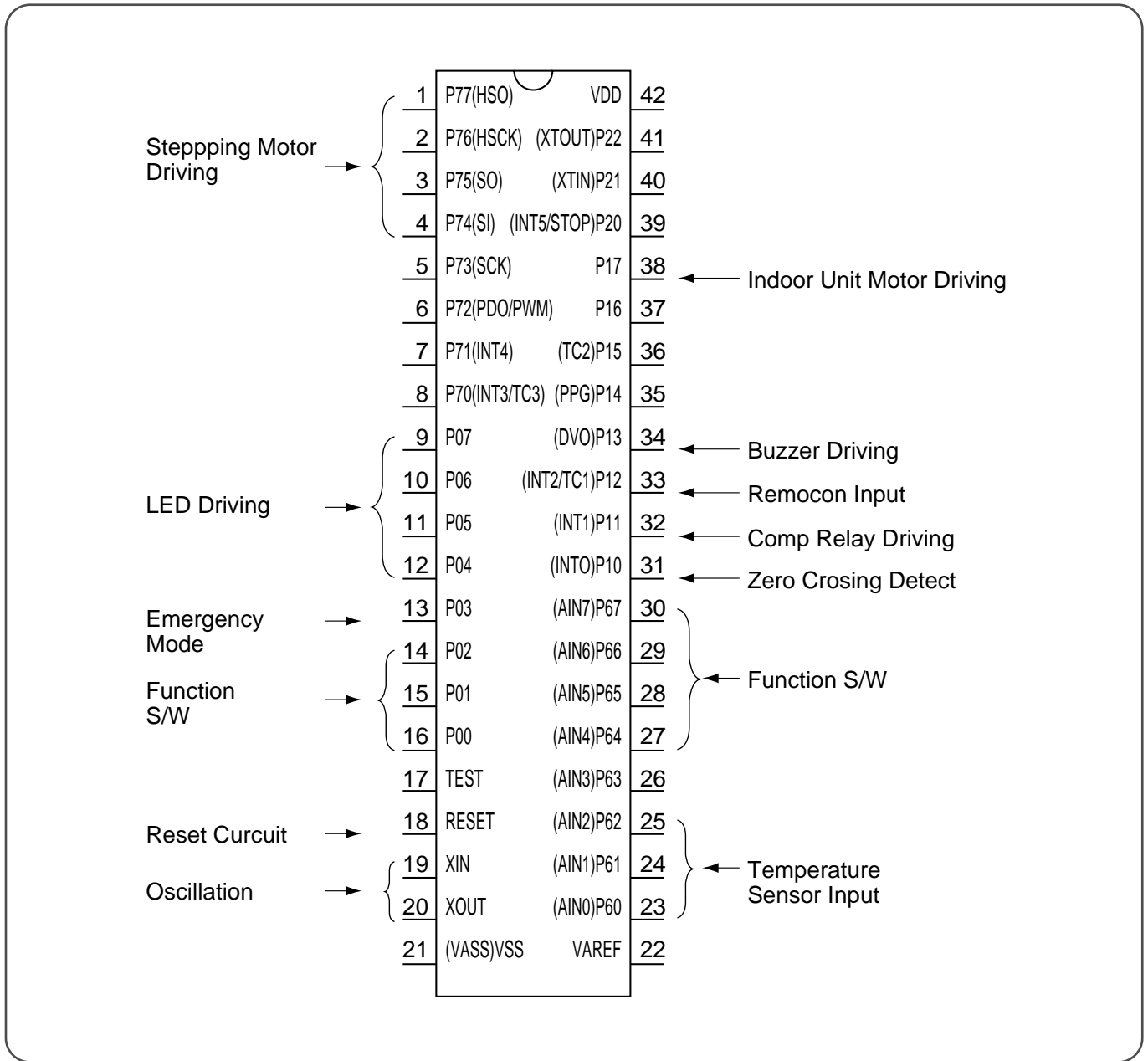

(5) U9 (KIA7042P) : RESET IC

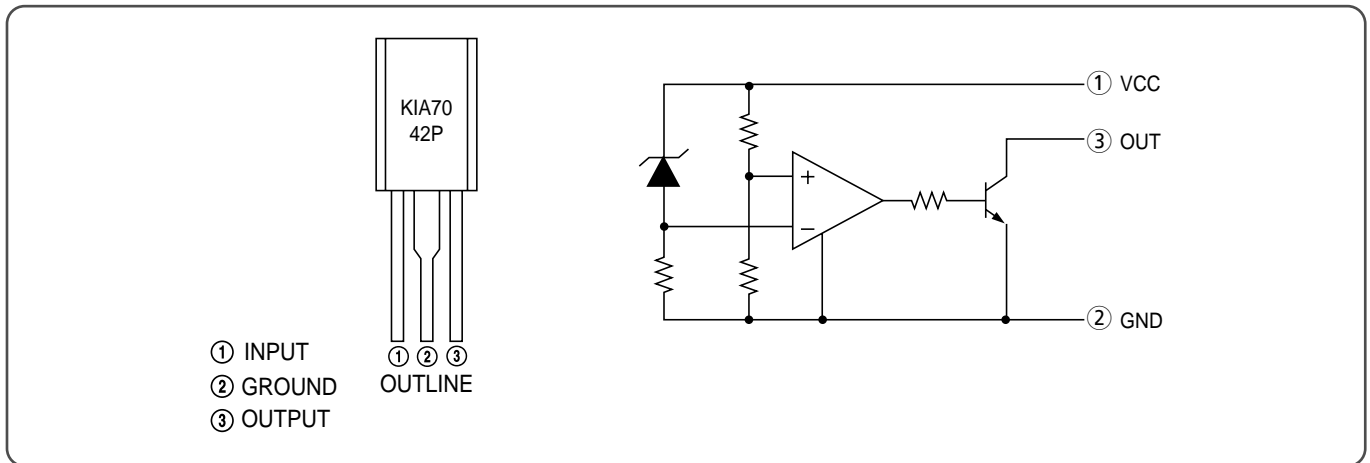

10. DISASSEMBLY INSTRUCTIONS

1 INDOOR UNIT

* DSB-070LH/DSB-091LH

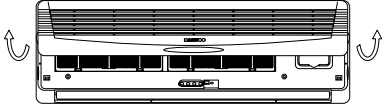
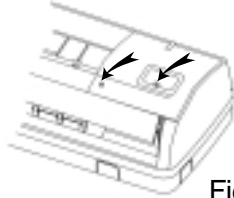
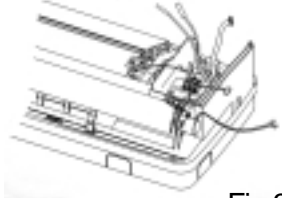
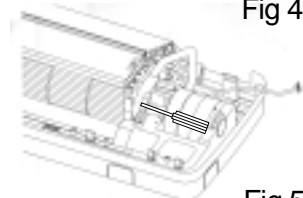
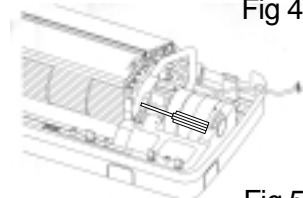
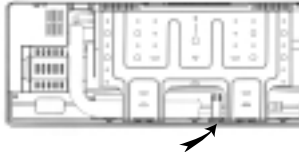
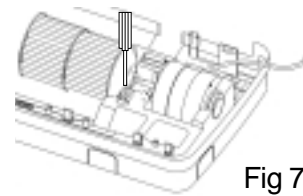
PROCEDURES	PHOTOS
<p>1. Stop the Air conditioner and disconnect the power cord from the wall outlet.</p>	
<p>2. Removing the Insert Grille and Frame Grille. (Fig 1~2)</p> <ol style="list-style-type: none"> ① Draw up the Insert Grille and remove it. ② Loosen one screw for fixing the Cover Ter-Block. ③ Loosen two screw at the Frame Grille. ④ Remove the Frame Grille. 	
<p>3. Removing the Control Box. (Fig 3)</p> <ol style="list-style-type: none"> ① Remove room and coil thermistors. ② Disconnect the fan motor lead wire from connection at the Control PCB. ③ Disconnect the stepping motor lead wire from connection at the Control PCB. ④ Remove the select switch from connection at the Control PCB. ⑤ Loosen a screw for fixing ground wire. ⑥ Remove the Control Box 	
<p>4. Removing the Drain Pan. (Fig 4)</p> <ol style="list-style-type: none"> ① Disconnect the Body drain hole. (left and right Body) ② Disconnect three hook and remove the Drain Pan. 	
<p>5. Removing the Indoor Evaporator. (Fig 5~6)</p> <ol style="list-style-type: none"> ① Remove one screw for fixing indoor Evaporator at the Body. ② Remove the hook for fixing Bracket Pipe at the back of Body. ③ Remove Indoor Evaporator. 	
<p>6. Removing the Cross Flow Fan. (Fig 7)</p> <ol style="list-style-type: none"> ① Remove set screw for fixing Motor shaft. ② Remove Cross Flow Fan. 	
<p>7. Remove Motor IDU and Bearing Plastic.</p>	

* DSB-121LH/DSB-122LH

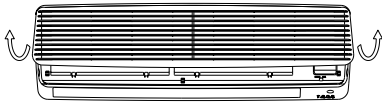
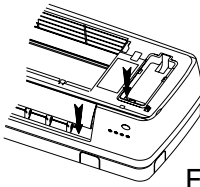
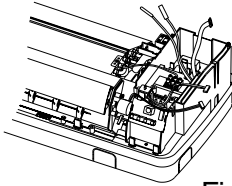
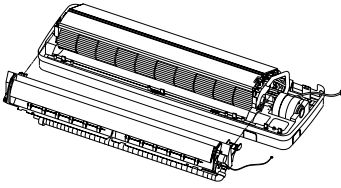
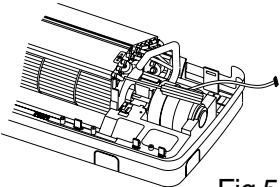
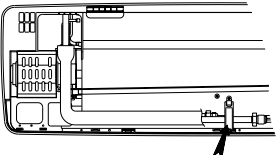
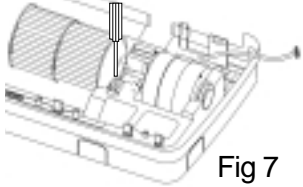

PROCEDURES	PHOTOS
<p>1. Stop the Air conditioner and disconnect the power cord from the wall outlet.</p>	
<p>2. Removing the Insert Grille and Frame Grille. (Fig 1~2)</p> <ol style="list-style-type: none"> ① Draw up the Insert Grille and remove it. ② Loosen two special screw for fixing the Cover Ter-Block. ③ Loosen three screw at the Body. ④ Remove the Frame Grille. 	
<p>3. Removing the Control Box. (Fig 3)</p> <ol style="list-style-type: none"> ① Remove room and coil thermistors. ② Disconnect the fan motor lead wire from connection at the Control PCB. ③ Disconnect the stepping motor lead wire from connection at the Control PCB. ④ Remove the select switch from connection at the Control PCB. ⑤ Loosen a screw for fixing ground wire. ⑥ Remove the Control Box 	
<p>4. Removing the Drain Pan. (Fig 4)</p> <ol style="list-style-type: none"> ① Disconnect the Body drain hole. (left and right Body) ② Disconnect three hook and remove the Drain Pan. 	
<p>5. Removing the Indoor Evaporator. (Fig 5~6)</p> <ol style="list-style-type: none"> ① Remove three screw for fixing indoor Evaporator at the Body. ② Remove the hook for fixing Bracket Pipe at the back of Body. ③ Remove Indoor Evaporator. 	
<p>6. Removing the Cross Flow Fan. (Fig 7)</p> <ol style="list-style-type: none"> ① Remove set screw for fixing Motor shaft. ② Remove Cross Flow Fan. 	
<p>7. Remove Motor IDU and Bearing Plastic.</p>	

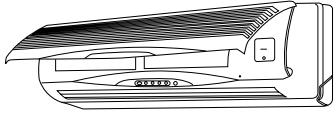
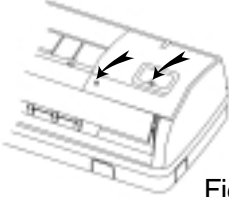
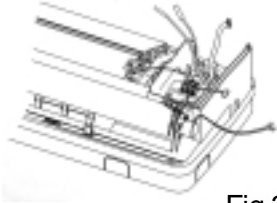
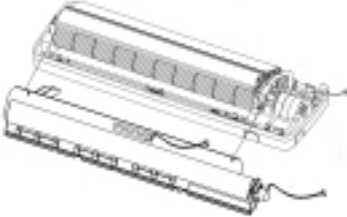
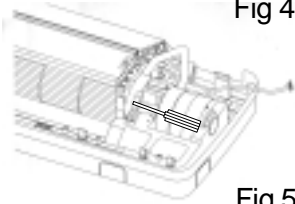
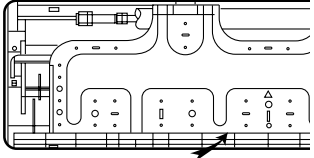
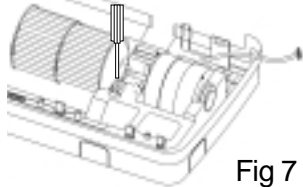
* DSB240LH

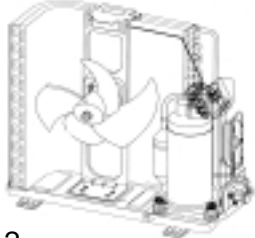
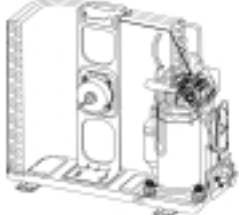
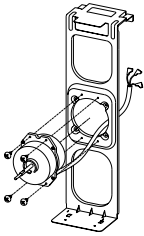

PROCEDURES	PHOTOS
<p>1. Stop the Air conditioner and disconnect the power cord from the wall outlet.</p>	 <p>Fig 1</p>
<p>2. Removing the Insert Grille and Frame Grille. (Fig 1~2)</p> <ol style="list-style-type: none"> ① Draw up the Insert Grille and remove it. ② Loosen one screw for fixing the Cover Ter-Block. ③ Loosen two screw at the Frame Grille. ④ Remove the Frame Grille. 	 <p>Fig 2</p>
<p>3. Removing the Control Box. (Fig 3)</p> <ol style="list-style-type: none"> ① Remove room and coil thermistors. ② Disconnect the fan motor lead wire from connection at the Control PCB. ③ Disconnect the stepping motor lead wire from connection at the Control PCB. ④ Remove the select switch from connection at the Control PCB. ⑤ Loosen a screw for fixing ground wire. ⑥ Remove the Control Box 	 <p>Fig 3</p>  <p>Fig 4</p>
<p>4. Removing the Drain Pan. (Fig 4)</p> <ol style="list-style-type: none"> ① Disconnect the Body drain hole. (left and right Body) ② Disconnect three hook and remove the Drain Pan. 	 <p>Fig 5</p>
<p>5. Removing the Indoor Evaporator. (Fig 5~6)</p> <ol style="list-style-type: none"> ① Remove the hook for fixing Plate mounting at the back of Body. ② Remove Indoor Evaporator. 	 <p>Fig 6</p>
<p>6. Removing the Cross Flow Fan. (Fig 7)</p> <ol style="list-style-type: none"> ① Remove set screw for fixing Motor shaft. ② Remove Cross Flow Fan. 	 <p>Fig 7</p>
<p>7. Remove Motor IDU and Bearing Plastic.</p>	

2 OUTDOOR UNIT

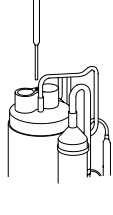
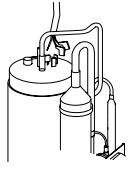
* DSB-070LH/DSB-091LH/DSB-121LH(After)

PROCEDURES	PHOTOS
<p>1. Stop the air conditioner and disconnect the wire from Indoor Unit to Outdoor Unit.</p>	
<p>2. Disassemble the case. (Fig 1~2)</p> <ol style="list-style-type: none"> ① Remove the Top Panel. (Loosen thirteen screw) ② Remove the Front Cabinet. (Loosen six screw) ③ Remove the Side Cabinet. (Loosen seven screw) ④ Remove the Guide Support. (Loosen two screw) 	<p>Fig 1</p> 
<p>3. Removing the Propeller Fan. (Fig 3)</p> <ol style="list-style-type: none"> ① Loosen the Nut for fixing the Propeller Fan. ② Remove the Plain Washer. ③ Remove the Propeller Fan. 	<p>Fig 2</p> 
<p>4. Removing the Motor ODU. (Fig 4)</p> <ol style="list-style-type: none"> ① Loosen four screw at Bracket Motor. ② Disconnect the wire at Control Panel and remove Motor ODU. 	<p>Fig 3</p> 
<p>5. Removing the Dual Capacitor. (Fig 5)</p> <ol style="list-style-type: none"> ① Disconnect the wire at Control Panel. ② Loosen a screw at Clamp Capacitor. ③ Remove the Dual Capacitor. 	<p>Fig 4</p> 
<p>6. Removing the Over load Protector. (Fig 6~7)</p> <ol style="list-style-type: none"> ① Loosen a Hex Nut at Terminal Cover. ② Remove the Terminal Cover. ③ Remove the wire at Over load Protector. ④ Remove the Over load Protector. 	<p>Fig 5</p> 
	<p>Fig 6</p>  <p>Fig 7</p>

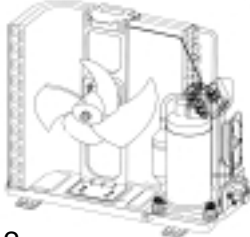
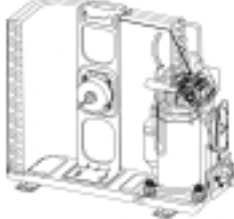
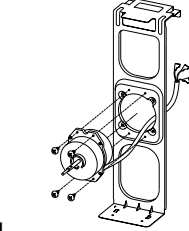
* DSB-121LH/DSB-122LH(After)

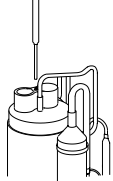
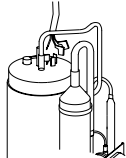
PROCEDURES	PHOTOS
<p>1. Stop the air conditioner and disconnect the wire from Indoor Unit to Outdoor Unit.</p>	
<p>2. Disassemble the case. (Fig 1~2)</p> <ol style="list-style-type: none"> ① Remove the Top Panel. (Loosen thirteen screw) ② Remove the Front Cabinet. (Loosen six screw) ③ Remove the Side Cabinet. (Loosen seven screw) ④ Remove the Guide Support. (Loosen two screw) 	<p>Fig 1</p> 
<p>3. Removing the Propeller Fan. (Fig 3)</p> <ol style="list-style-type: none"> ① Loosen the Nut for fixing the Propeller Fan. ② Remove the Plain Washer. ③ Remove the Propeller Fan. 	<p>Fig 2</p> 
<p>4. Removing the Motor ODU. (Fig 4)</p> <ol style="list-style-type: none"> ① Loosen four screw at Bracket Motor. ② Disconnect the wire at Control Panel and remove Motor ODU. 	<p>Fig 3</p> 
<p>5. Removing the Dual Capacitor. (Fig 5)</p> <ol style="list-style-type: none"> ① Disconnect the wire at Control Panel. ② Loosen a screw at Clamp Capacitor. ③ Remove the Dual Capacitor. 	<p>Fig 4</p> 
<p>6. Removing the Over load Protector. (Fig 6~7)</p> <ol style="list-style-type: none"> ① Loosen a Hex Nut at Terminal Cover. ② Remove the Terminal Cover. ③ Remove the wire at Over load Protector. ④ Remove the Over load Protector. 	<p>Fig 5</p> 
	<p>Fig 7</p> 

* DSB-240LH

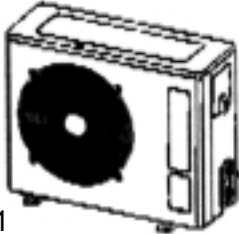
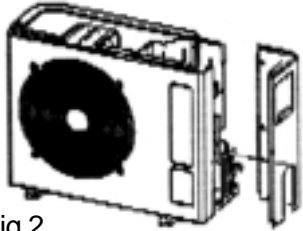
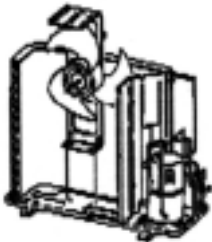
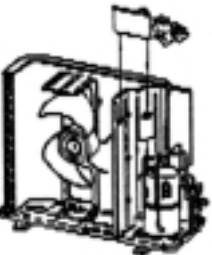
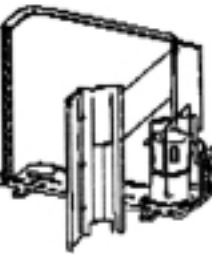
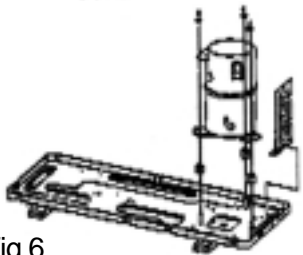
PROCEDURES	PHOTOS
<p>1. Stop the air conditioner and dis connect the wire from in door unit to out door unit.</p>	
<p>2. Disassemble the case. (Fig 1~2)</p> <ol style="list-style-type: none"> ① Remove the Top Panel. (Loosen two screw and remove six hook) ② Remove the Front Cabinet. (Loosen four screw and four hook) ③ Remove the Side Cabinet and Back Cabinet. (Loosen eight screw) 	<p>Fig 1</p> 
<p>3. Removing the Propeller Fan. (Fig 3)</p> <ol style="list-style-type: none"> ① Loosen the screw for fixing the motor bracket. ② Remove the Plain Washer. ③ Remove the Propeller Fan. 	<p>Fig 2</p> 
<p>4. Remove the panel control. (Fig 4)</p> <ol style="list-style-type: none"> ① Disconnect the wire at control panel. ② Loosen a screw at panel control. ③ Remove the parts on panel control. 	<p>Fig 3</p> 
<p>5. Remove the partition panel. (Fig 5)</p> <ol style="list-style-type: none"> ① Loosen four screws at bracket motor. ② Disconnect the wire at control panel. 	<p>Fig 4</p> 
<p>6. Removing the Over load Protector. (Fig 6)</p> <ol style="list-style-type: none"> ① Remove the cocondenser ② Loosen three volts at compressor. ③ Remove the compressor. 	<p>Fig 5</p>  <p>Fig 6</p>

3 EXPLODED DIAGRAM (Indoor Unit)

* DSB-070LH/DSB-091LH

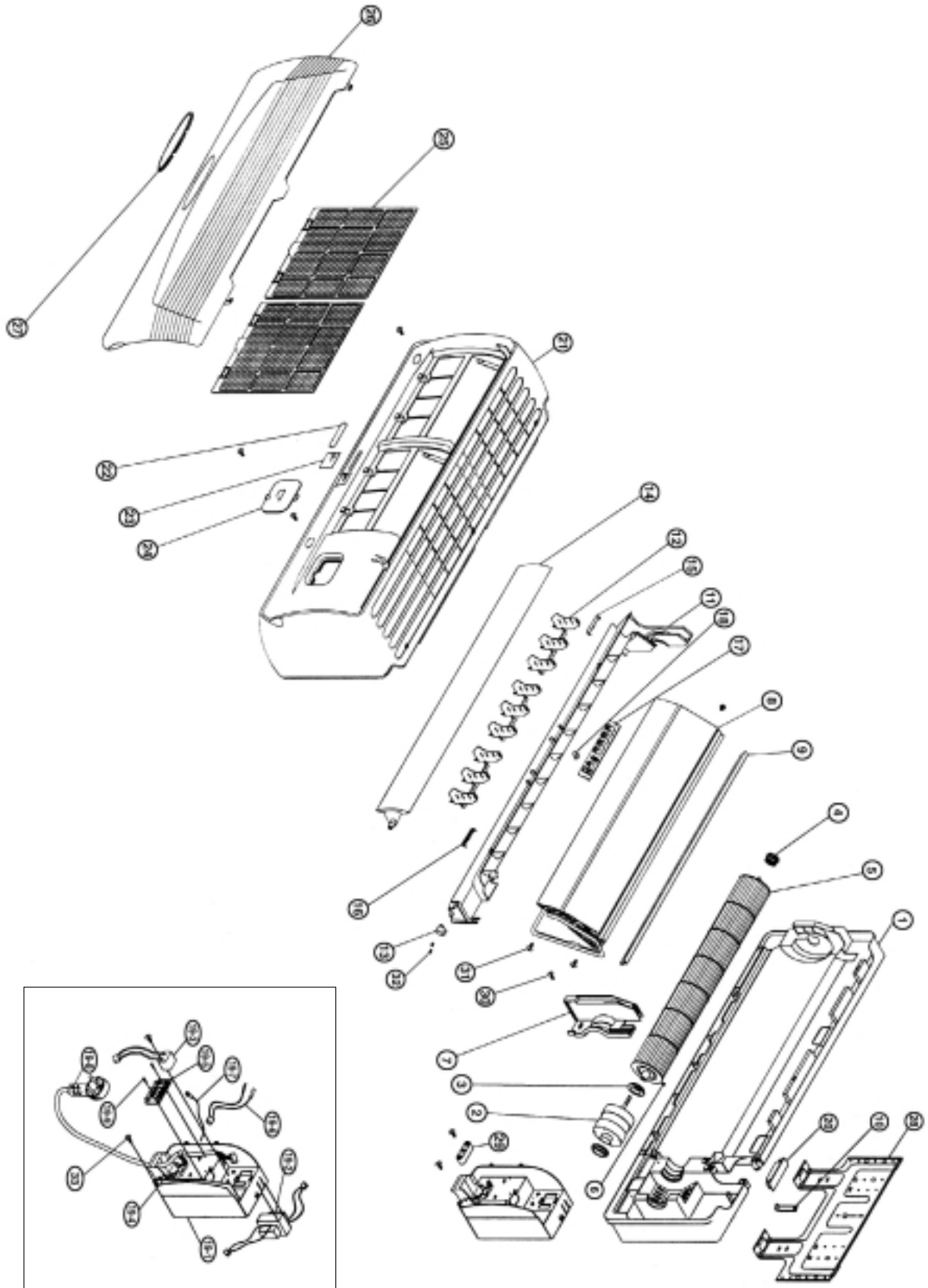

* DSB-070LH/DSB-091LH PART LIST(INDOOR UNIT)

✓ **Caution:** In this Service Manual, some parts can be changed for improving, their performance without notice in the parts list. So, if you need the latest parts information, please refer to PPL(Parts Price List) in Service information Center(<http://svc.dwe.co.kr>)

No	PART CODE	PART NAME	Q'TY	SPEC	REMARK
1	3100400300	BODY	1	HIPS T2.0	
2	3108004700	MOTOR IDU	1	IC-8417DWKF5A	
3	3101500400	CUSHION MOTOR	2	CR Ø30	
4	3106400400	BEARING PLASTIC ASS'Y	1		
5	3100053700	FAN CROSS FLOW ASS'Y	1	Ø90.0xL540	
6	7485401012	SET SCREW	1	6S-4x10-E MFZN	
7	3103002600	HOLDER MOTOR	1	HIPS T2.0	
8	3100053800	EVAPORATOR ASS'Y	1		
9	3102501200	EVAP. GUIDE	1	PVC T1.0 L536	
10	3100603800	BRACKET PIPE	1	HIPS T2.0	
11	3108100800	PAN DRAIN	1	HIPS T2.0	
12	3106501600	BLADE VERTICAL	3	P.P. T1.5	
13	3108003900	MOTOR STEPPING	1	MP24GA or GSP-24SW-061	
14	3107600400	FLAP	1	HIPS T2.5	
15	3101404800	COVER WIRE L	1	HIPS	
16	3101404900	COVER WIRE R	1	HIPS	
17	3100054200	LED PCB ASS'Y	1		
18	3100901600	CAP RUBBER	1	SILICON	
19-1	3100508400	CONTROL BOX	1	P.P.+G.F.20%	
19-2	5EPV050120	TRANSFORMER	1	DWA-220B	
19-3	3106900300	CAPACITOR SH. M. B	1	1.0µF 400VAC	
19-4	3100054400	CONTROL PCB ASS'Y	1		
19-5	3108912310	TERMINAL BLOCK	1	SN-DBW-05P	
19-6	3104896300	SENSOR ID ASS'Y	1	PTM-KD-43C-D2	
19-7	3102797910	HARNESS	1	I.D EARTH	
19-8	31013A24B1	POWER CORD ASS'Y	1	16A 250V	
19-9	7111301611	SCREW TAPPING	2	T1S PAN 3x16 MFZN	
20	3100400400	BODY-TOP	1	HIPS T2.0	
21	3102200800	FRAME GRILLE	1	HIPS T2.5	
22	3104508700	PLATE LED	1	PC SHEET T0.2	
23	3104510200	PLATE SWITCH	1	PC SHEET T0.2	
24	3101404600	COVER TERMINAL BLOCK	1	HIPS T2.0	
25	3102200900	FILTER FRAME	2	P.P. T2.0	
26	3102402200	INSERT GRILLE	1	HIPS T2.5	
27	3101403900	COVER LED	1	ABS(TRANSPARENCY) T2.0	
28	3104507200	PLATE MOUNTING	1	SBHG 1 T0.7	
29	3101203000	CLAMP WIRE	1	P.P.+G.F.20%	
30	7S422X40B1	SPECIAL SCREW	8	TT2 TRS SE 4x12 MFZN	
31	7112400611	SCREW TAPPING	2	T1S TRS 4x6 MFZN	
32	7141400811	SCREW TAPPING	2	T2 PAN 4x8 MFZN	
33	7122401211	SCREW TAPPING	1	T2S TRS 4x12 MFZN	

* DSB-121LH

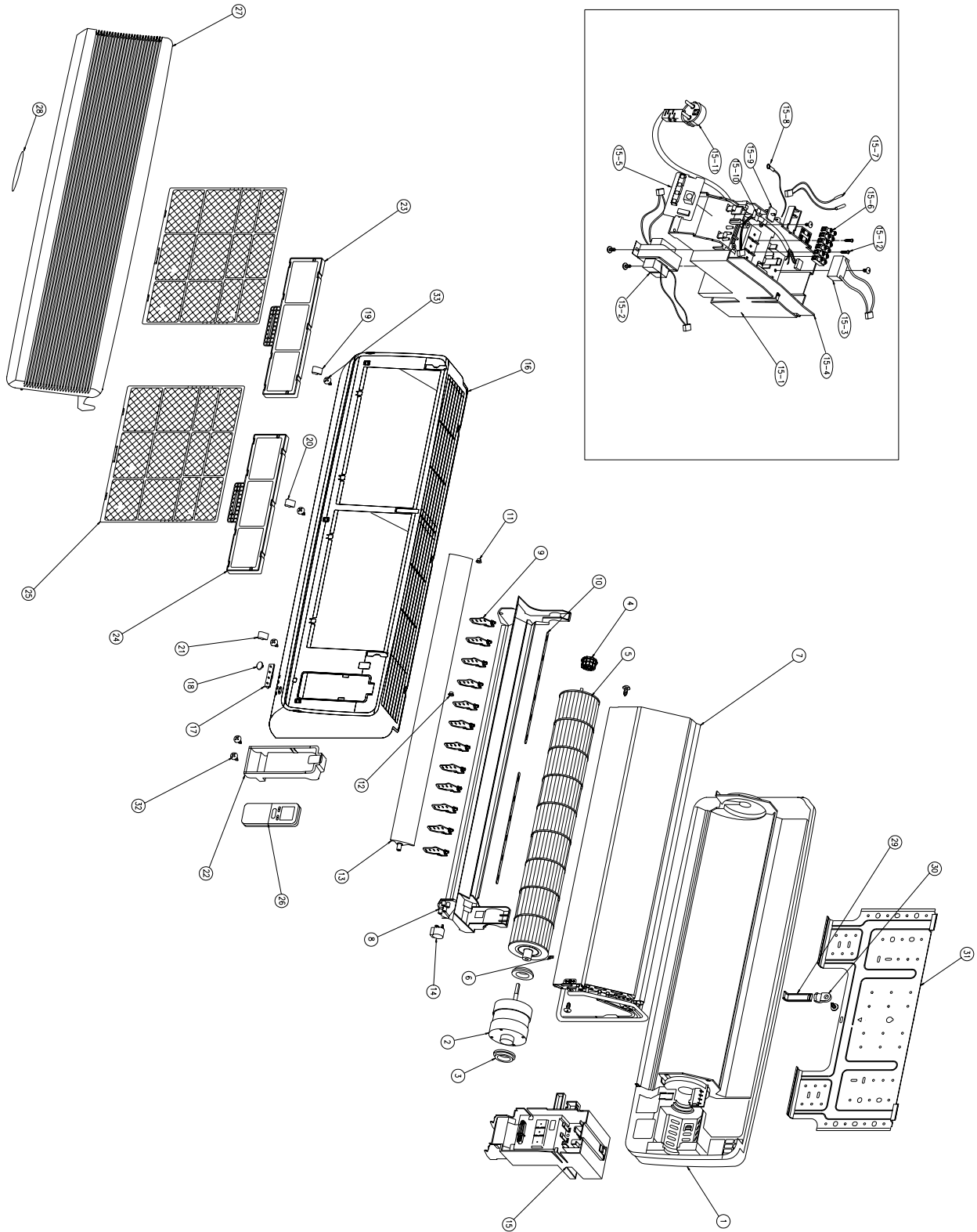

* DSB-121LH/122LH PART LIST(INDOOR UNIT)

✓ **Caution:** In this Service Manual, some parts can be changed for improving, their performance without notice in the parts list. So, if you need the latest parts information, please refer to PPL(Parts Price List) in Service information Center(<http://svc.dwe.co.kr>)

No	PART CODE	PART NAME	Q'TY	SPEC	REMARK
1	3100400201	BODY	1	ABS or HIPS	
2	3108001220	MOTOR IDU	1	220V 50/60Hz	
3	3101500400	CUSHION MOTOR	2	CR	
4	3106400200	BEARING PLASTIC ASS'Y	1		
5	3100014400	FAN CROSS FLOW ASS'Y	1	SAN+G. F20%	
6	7485401012	SET SCREW	1	6S-4 X 10-E	
7	3100014300	EVAPORATOR ASS'Y	1		
8	3108100401	PAN DRAIN	1	ABS	
9	3106500800	BLADE VERTICAL MN	12	ABS	
10	3106300800	BAR BLADE	2	ABS	
11	3100700800	BUSHING L	1	POM	
12	3100700700	BUSHING R	1	POM	
13	3107600300	FLAP	1	ABS	
14	3108000100	MOTOR STEPPING	1	MG28GA	
15	3100038210	CONTROL BOX ASS'Y	1		BUYER
15-1	3100503101	BOX CONTROL	1	P.P+G.F30%	
15-2	5EPV050100	TRANS FORMER	1	DWA220A-50/60Hz	
15-3	3106900300	CAPACITOR SH.M.B	1	1.0 μ F 400VAC	
15-4	3100054400	CONTROL PCB ASS'Y	1		
15-5	3100054200	LED PCB ASS'Y	1		
15-6	3108912301	TERMINAL BLOCK	1	SN-DBW-05P	
15-7	3104896300	SENSOR I.D ASS'Y	1	PTM-KD43C-D2	

*** DSB-121LH/121LH PART LIST(INDOOR UNIT)**

No	PART CODE	PART NAME	Q'TY	SPEC	REMARK
15-8	3102797910	HARNESS	1	I.D EARTH	
15-9	3103400300	KNOB RESET SWITCH	1	ABS	
15-10	3100024000	MODE SELECT ASS'Y	1	TS-11 & HARNESS	
15-11	3101395060	POWER CORD ASS'Y	1		BUYER
15-12	7111301611	TAPPING SCREW	2	T1S PAN 3 X 16 MFZN	
16	3102200401	FRAME	1	ABS	BUYER
17	3103600300	LAMP INDICATE	1	MIPS	
18	3105500500	WINDOW SENSOR	1	ACRIL	
19	3100901000	CAP FRAME L	1	ABS	
20	3100900900	CAP FRAME C	1	ABS	
21	3100900800	CAP FRAME R	1	ABS	
22	3101401701	COVER TER-BLOCK	1	ABS	
23	3100017800	FILTER ELECTRO ASS'Y	1		
24	3100017900	FILTER CARBON ASS'Y	1		
25	3100017700	FILTER PRE ASS'Y	2		
26		REMOCON ASS'Y	1		BUYER
27	3102401500	INSERT GRILLE	1	ABS	
28	3107500200	EMBLEM	1	URETANE	BUYER
29	3100602400	BRACKET PIPE	1	HIPS	
30	3101201200	CLAMP BRACKET PIPE	1	HIPS	
31	3104503900	PLATE MOUNTING	1	SBHG1	
32	3106001600	SPECIAL SCREW	1	T2 4 X 16 MFNI LOCKING	
33	7S422X40B1	SPECIAL SCREW	13	TT2 TRS SE 4x12 MFZN	

* NO 15, 15-11, 16, 26, 28 Will be changed depend on export destination & buyer requirements.

EXPLODED DIAGRAM (INDOOR UNIT)

* DSB-240LH

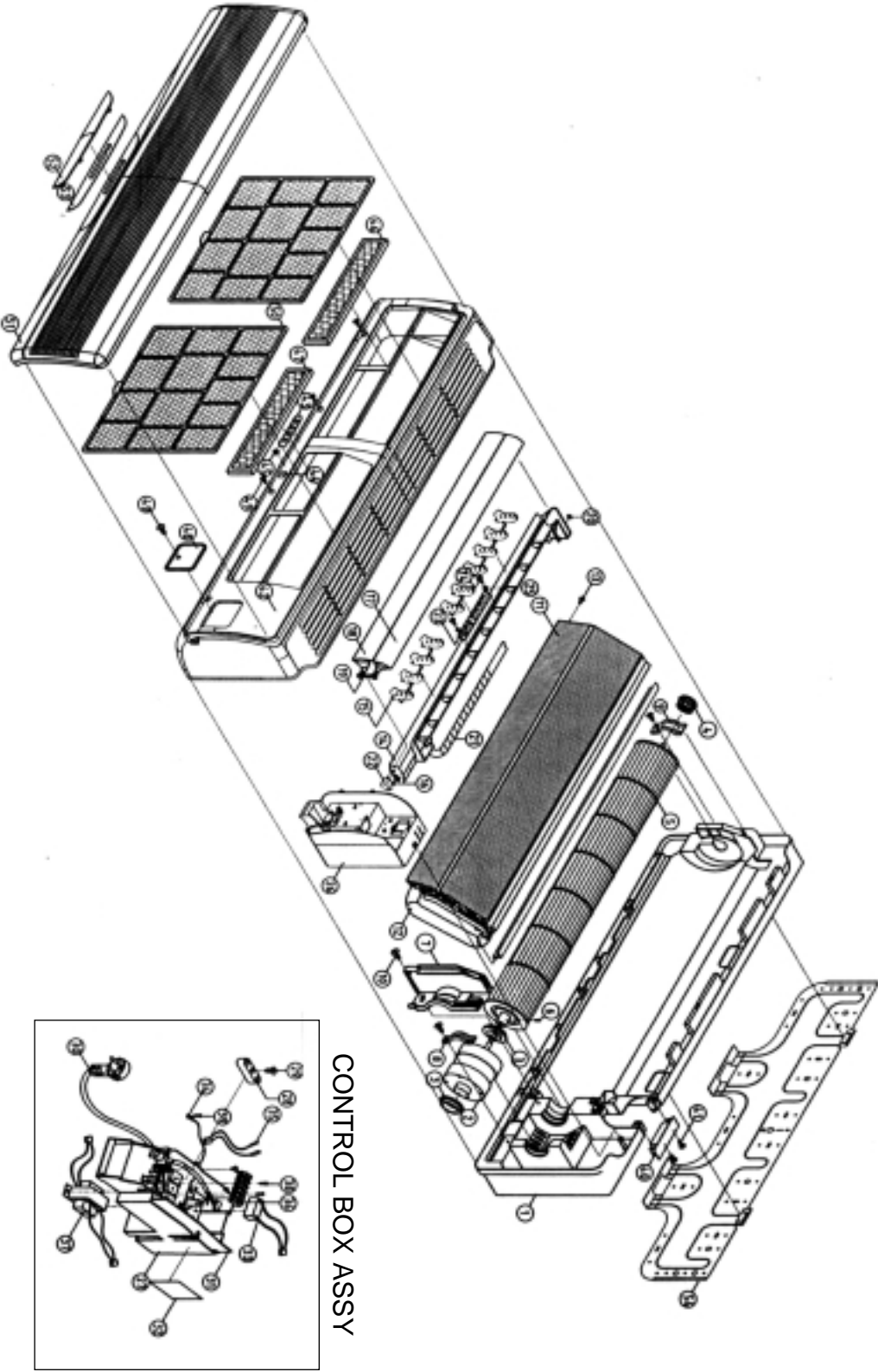

* DSB-240LH PART LIST (INDOOR UNIT)

✓ **Caution:** In this Service Manual, some parts can be changed for improving, their performance without notice in the parts list. So, if you need the latest parts information, please refer to PPL(Parts Price List) in Service information Center(<http://svc.dwe.co.kr>)

No	PART CODE	PART NAME	Q'TY	SPEC	REMARK
1	3100400600	BODY	1	DSB-240L/LH	
2	3108007500	MOTOR FCU	1	IC-9430DWKG7A	
3	3101500400	CUSHION MOTOR	2	CR I.D30 (R/W45)	
4	3106400200	BEARING PLASTIC ASSY	2	O.D37 .0*I.D6.0	
5	3100076400	FAN CROSS FLOW ASSY	1	Ø100XL864	
6	7485401012	SET SCREW	1	6S-4*10-E MFZN(BLACK)	
7	3103003800	HOLDER MOTOR L/B	1	DSB-240L/LH	
8	3103003900	HOLDER MOTOR R	1	DSB-240L/LH	
9	3103004000	HOLDER BEARING	1	ABS T2.5	
10	7172401211	SCREW TAPPING	3	TT2 TRS 4*12 MFZN	
11	3100089100	EVAPORATOR	1	ASSY	
12	3104440100	PIPE ARTRON HOSE	1	O.D:42 I.D:26 T=7, F-PE	
13	7172401211	SCREW TAPPING	1	TT2 TRS 4*12 MFZN	
14	3108101400	PAN DRAIN	1	DSB-240L/LH	
15	3106502700	BLADE VERTICAL (M)	2.5	DSB-240L/LH J360A	
16	7141400811	SCREW TAPPING	1	T2 PAN 4X8 MFZN	
17	3107600500	FLAP UP	2	DSB-240L/LH	
18	3107600600	FLAP DOWN	1	DSB-240L/LH	
19	3107801700	LINK FLAP	1	DSB-240L/LH	
20	3100702000	BUSHING	2	DSB-240L/LH	
21	3103200800	HOSE DRAIN ASSY	1	ASSY	
22	3108007600	MOTOR STEPPING	1	GSP-24RW-062	
23	3104301700	LED PCB ASSY	1	18/24K (150X24.5X1.6T)	
24	7112300611	SCREW TAPPING	2	T1, TRS M3*6	
25	3106002900	WASHER PLASTIC	2	IS Ø3	
26	3100077000	CONTROL BOX ASSY	1	ASSY	
27	3100510700	BOX CONTROL	1	DSB-240L/LH	
28	3101200400	CLAMP POWER CORD	1	DA-5N	
29	7172401211	SCREW TAPPING	2	TT2 TRS 4*12 MFZN	
30	3101300440	POWER CORD ASSY	1	SJT 3X14 AWG105	
31	3104300830	CONTROL PCB ASSY	1	240LH(A), 240LH(B)	

*** DSB-240LH PART LIST (INDOOR UNIT)**

No	PART CODE	PART NAME	Q'TY	SPEC	REMARK
32	2150013200	AL FOIL EMI	0.1	AL100P (W100XL100)	
33	3106902400	CAPACITOR SH.M.B	1	2.0MF 400V	
34	3102797910	HARNESS EARTH	1	GREEN/YELLOW L170mm	
35	3104896300	SENSOR ID ASSY	1	NTM-KD43C-D1D2 L450, L330	
36	3108912320	TERMINAL BLOCK	1	SN-DBW-4P	
37	5EPV050120	TRANSFORMER	1	DWA-220B	
38	7172401211	SCREW TAPPING	2	TT2 TRS 4*12 MFZN	
39	7S422X40B1	SPECIAL SCREW	2	TTS TRS SE 4*12 MFZN	
40	3100400700	BODY TOP	1	DSB-240L/LH	
41	7172401211	SCREW TAPPING	2	TT2 TRS 4*12 MFZN	
42	3102201400	FRAME GRILLE	1	DSB-240L/LH	
43	3104512400	PLATE LED	1	PC SHEET T0.2	
44	3104510200	PLATE SWITCH	1	PC SHEET T0.2	
45	3103401400	KNOB SWITCH	1	DSB-240L/LH	
46	3100017810	FILTER ELECTRO ASSY	1	070MG/HG	
47	3100017910	FILTER CARBON ASSY	1	070MG/HG	
48	3101406820	COVER T/BLOCK	1	ABS (DSB-240L/LH)	
49	7112401211	SCREW TAPPING	4	T1 TRS 4*12 MFZN	
50	3102201500	FILTER FRAME	2	DSB-240L/LH J360A	
51	3102403500	GRILLE INSERT	1	DSB-240L/LH	
52	3101406900	COVER LED	1	DSB-240L/LH	
53	3104512600	PLATE INSERT GRILLE	1	PET T=0.1	
54	3104511800	PLATE MOUNTING	1	DSB-240L/LH	

4 EXPLODED DIAGRAM (Outdoor Unit)

* DSB-070LH/DSB-091LH/DSB-121LH/DSB-122LH(After)

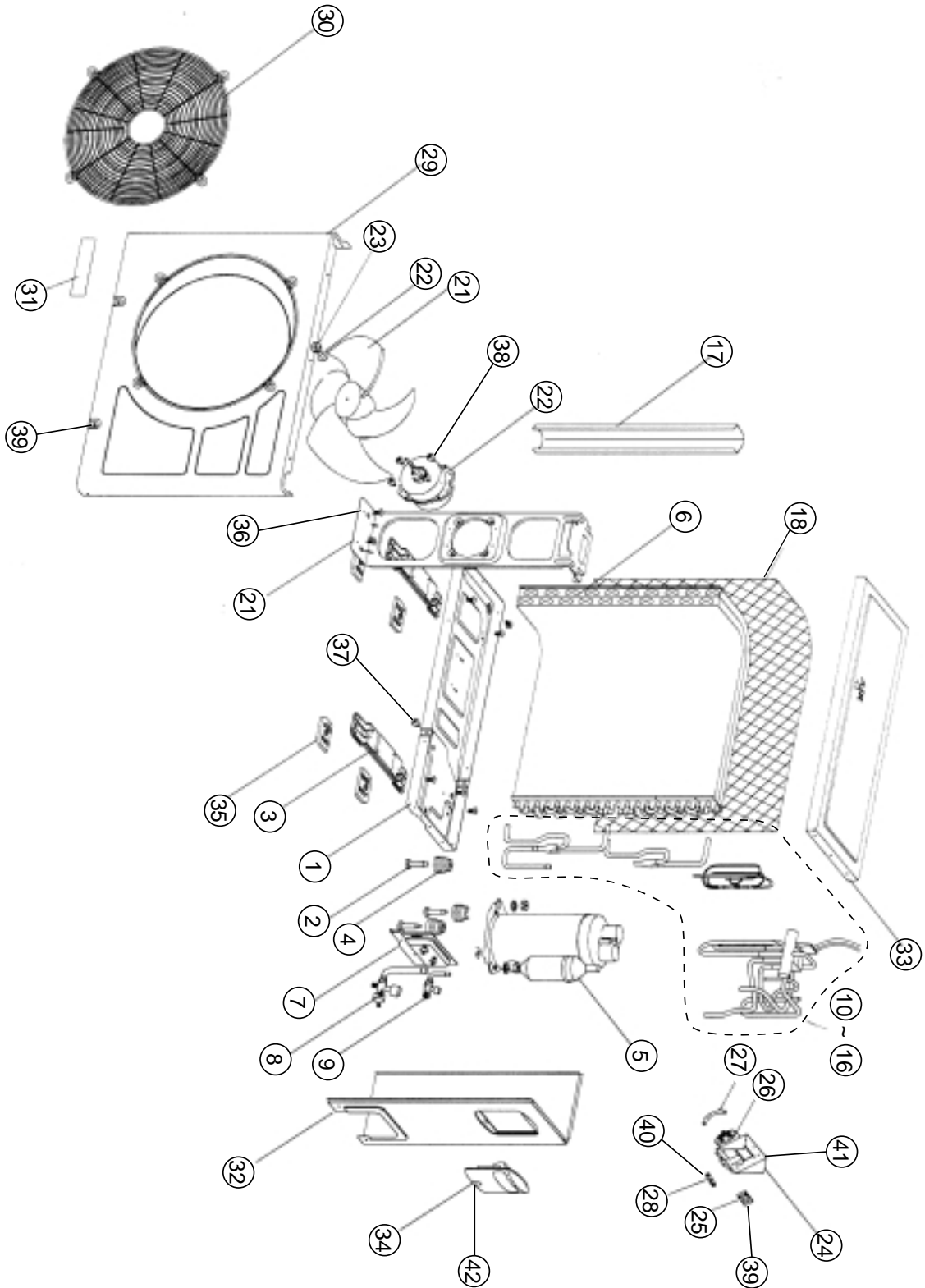

*** DSB-070LH/DSB-091LH/DSB-121LH/DSB-122LH(After) PART LIST(OUTDOOR UNIT)**

✓ **Caution:** In this Service Manual, some parts can be changed for improving, their performance without notice in the parts list. So, if you need the latest parts information, please refer to PPL(Parts Price List) in Service information Center(<http://svc.dwe.co.kr>)

No	PART CODE	PART NAME	Q'TY	SPEC	REMARK
1	3100300511	PAN BASE	3	SECC T1.2	070LH(LG COMP. QB134PL12B)
	3100300521				091LH(LG COMP. QK185PN13B)
	3100300511				091LH(DW COMP. RBB100A00A)
	3100300531				121LH(DW COMP. RCB150A001)
2	3107101180	COMP. BOLT	3	M8 x L47.5	070LH(LG COMP. QB134PL12B)
	310600900			MB x L46.5	091LH(LG COMP. QK185PN13B)
					091LH(DW COMP. RBB100A001)
					121LH(DW COMP. RCB150A001)
3	3102100800	FOOT	2	SECC T1.2	
4	3107101110	COMP. GROMMET	3	EPDM	070LH(LG COMP. QB134PL12B)
	3108134AE0				091LH(LG COMP. QK185PN13B)
					091LH(DW COMP. RBB100A001)
					121LH(DW COMP. RCB150A001)
5	3107101200	COMPRESSOR ASS'Y	1	QB 134PL12B	070LH
	3107101900			QK 185PN13B	091LH
	3RC0020KE0			RBB100A001	
	3100030GE0			RCB 150A001	121LH
6	3100054900	CONDENSER ASS'Y	1	L465xW208.5xH508	070LH(LG COMP. QB134PL12B)
	3100054910				091LH(DW COMP. RBB100A001)
					091LH(LG COMP. QK185PN13B)
					3100037010
7	3100602200	BRACKET SERVICE	1	SECC T1.2	
8	3105400700	SERVICE VALVE	1	1/2	
9	3105400800	SERVICE VALVE	1	1/4	
10	3104410710	PIPE COND IN ASS'Y	1	C1220T	070LH/091LH/121H
11	3104412810	PIPE COND OUT ASS'Y	1	C1220T	070LH(LG COMP. QB134PL12B)
					091LH(DW COMP. RBB100A001)
	3104412820				121LH(DW COMP. RCB150A001)
12	3104411411	PIPE OUTLET	1	C1220T	070LH(LG COMP. QB134PL12B)
	3104411420				091LH(DW COMP. RBB100A001)
					091LH(LG COMP. QK185PN13B)
13	3100061901	PIPE FILTER ASS'Y	1	C1220T	070LH(LG COMP. QB134PL12B)
	3100062001				091LH(LG COMP. QK185PN13B)
					091LH(DW COMP. RBB100A00A)
	3100037800				121LH(DW COMP. RCB150A001)
14	3104400300	PIPE SENSOR	1	C1220T	070LH/091LH/121LH

*** DSB-070LH/DSB-091LH/DSB-121LH/DSB-122LH(After) PART LIST(OUTDOOR UNIT)**

No	PART CODE	PART NAME	Q'TY	SPEC	REMARK
15	3100062100	PIPE REVERSING ASS'Y	1	C1220T	070LH(LG COMP. QB134PL12B)
	3100069100				091LH(LG COMP. QK185PN13B)
	3100062200				091LH(DW COMP. RBB100A00A)
	3100038810				121LH(DW COMP. RCB150A001)
16	3104401010	REVERSING VALVE	1	CHV-0104	070LH/091LH
	3105401000			VH7-ATYPE	121LH
17	3102501100	GUIDE SUPPORT	1	SECC T1.2	
18	3102402600	GRILLE CONDENSER	1	P.E. 660x525.5xT3.5	
19	3100601901	BRACKET MOTOR	1	SBHG1 T1.2	
20	3108004000	MOTOR ODU	1	IC-9625DWLF5A	070LH
	3108004100			IC-9625DWLF5A	091LH
	3108000800			IC-9430DWLC5B	121LH
21	3101801000	FAN PROPELLER	1	ABS+G.F20% (BLACK)	
22	7400208411	WASHER PLAIN	1	PW-2-8 MFZN	
23	7392800011	NUT LOCK	1	M8 x P1.25 MFZN	
24	3104201900	PANEL CONTROL	1	SBHG1 T0.8	
25	3108912301	TERMINAL BLOCK	1	SN-DBW-05P	
26	3109501201	CAPACITOR DUAL	1	1.8+25uF 400VAC	070LH(LG COMP. QB134PL12B)
	3109502030			1.8+35uF 400VAC	091LH(LG COMP. QK185PN13B)
	3109502010			1.8+30uF 400VAC	091LH(DW COMP. RBB100A00A)
	3109501301			3.5+35uF 400VAC	121LH(DW COMP. RCB150A001)
27	3101201100	CLAMP CAPACITOR	1	SBHG1 T1.0	
28	3101202000	CLAMP CORD	1	NYLON	
29	3100801200	CABINET FRONT	1	SECC T0.8	
30	3102402500	GRILLE DISCHAGE	1	Ø 425.5	
31	3103502210	LABEL BRAND	1	P.C.FILM T0.4	
32	3100801300	CABINET SIDE	1	SECC T0.8	
33	3104201800	PANEL TOP	1	SECC T0.8	
34	3102600300	HANDLE	1	A.E.S. T2.5 (WH104A)	
35	3102101000	FOOT CUSHION	4	NBR	
36	7112401211	TAPPING SCREW	11	T1S TRS 4X12 MFZN	
37	7112401214	TAPPING SCREW+PVC WASHER	29	T1S TRS 4X12 MFZN	
38	7112401211	TAPPING SCREW	4	T1S TRS 4X12 MFZN	070LH/091LH
	7112402011			T1S TRS 4X20 MFZN	121LH
39	7111301611	TAPPING SCREW	2	T1S PAN 3X16 MFZN	
40	7112403011	TAPPING SCREW	3	T1S TRS 4X30 MFZN	
41	7S432X40A1	SPECIAL SCREW	1	TT3 TRS SE 4X8 MFZN	
42	7112401614	TAPPING SCREW+PVC WASHER	5	T1S TRS 4X16 MFZN	

* DSB-121LH/DSB-122LH(Before)

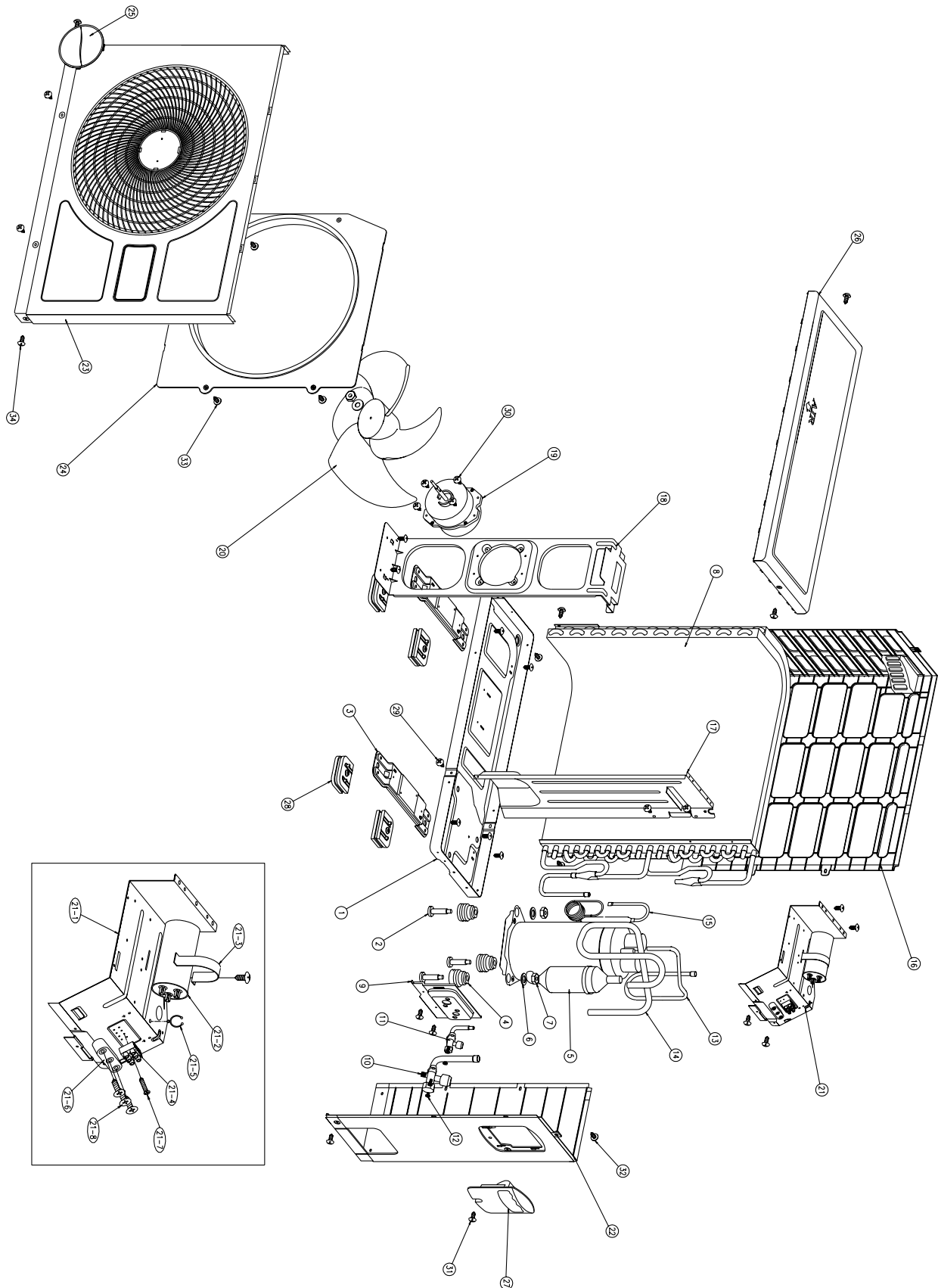

* DSB-121LH/DSB-121LH(Before) PART LIST(OUTDOOR UNIT)

✓ **Caution:** In this Service Manual, some parts can be changed for improving, their performance without notice in the parts list. So, if you need the latest parts information, please refer to PPL(Parts Price List) in Service information Center(<http://svc.dwe.co.kr>)

No	PART CODE	PART NAME	Q'TY	SPEC	REMARK
1	3100300501	PAN BASE	1	SECC	
2	3106000900	COMP BOLT	3	M8 X L46.5 MFZN	
3	3102100800	FOOT	2	SECC	
4	3108134AE0	GRMMET	3	EPDM	
5	3100030CE0	COMPRESSOR ASS'Y	1	RCB150A001	
6	7400208411	WASHER PLANE	4	M8.4 X 0.D22 X T1.6	
7	7392800011	NUT LOCK	4	M8 X P1.25 MFZN	
8	3100037000	CONDENSER ASS'Y	1		
9	3100015100	BRACKET SERVICE ASS'Y	1		
10	3105401100	SERVICE VALVE	1	1/2"	
11	3105400700	SERVICE VALVE	1	1/4"	
12	7347602011	BOLT HEX	4	M6 X L20 MFZN	
13	3100038800	PIPE REVERSING ASS'Y	1		
14	3100037800	FILTER ASS'Y	1	C1220T	
15	3104503800	PLATE PARTITION	1	SBHG1	
16	3100800601	CABINET BACK	1	A.E.S or ABS	
17	3100601901	BRACKET MOTOR	1	SBHG1	
18	3108000810	MOTOR ODU	1	220-240/50Hz	
19	3101801000	FAN PROPELLER	1	ABS+G.F20%	
20	3100038410	PANEL CONTROL ASS'Y	1		
20-1	3104201301	PANEL CONTROL	1	SBHG1	
20-2	3109501301	CAPACITOR DUAL		3.5+35μF 400VAC	

*** DSB-121L/DSB-122L(Before) PART LIST(OUTDOOR UNIT)**

No	PART CODE	PART NAME	Q'TY	SPEC	REMARK
20-3	3101201100	CLAMP CAPACITOR	1	SBHG1	
20-4	3108912301	TERMINAL BLOCK	1	SN-DBW-05P	
20-5	3103800300	LOCK TWIST	1	DATL-250	
20-6	3101202000	CLAMP CORD	1	NYLON	
20-7	7111301611	TAPPING SCREW	2	T1S PAN 3 X 16 MFZN	
20-8	7112403011	TAPPING SCREW	3	T1S TRS 4 X 30 MFZN	
21	3100800701	CABINET SIDE	1	A.E.S or ABS	
22	3100800501	CABINET FRONT	1	A.E.S or ABS	
23	3104201201	PANEL ORIFICE	1	P.P + TALK30%	
24	3101401900	COVER GRILLE	1	A.E.S or ABS	
25	3104201100	PANEL TOP	1	A.E.S or ABS	
26	3102600300	HANDLE	1	A.E.S or ABS	
27	3104895000	O.D SENSOR ASS'Y	1	PTM-KD43C-D3	
28	3102100710	FOOT CUSHION	4	NBR	
29	3106001600	SPECIAL SCREW	1	T2 4X16 MFNI LOCKING	
30	7112401614	TAPPING SCREW	4	T1S TRS 4X16 MFNI+PVC/W	
31	7S422X40B1	SPECIAL SCREW	4	TT2 TRS SE 4X12 MFZN	
32	7112401214	TAPPING SCREW	12	T1S TRS 4X12 MFNI+PVC/W	
33	7S432X4018	SPECIAL SCREW	5	TT3 TRS SE 4X8 MFZN	
34	7112402011	TAPPING SCREW	4	T1S TRS 4X20 MFZN	
35	7112401211	TAPPING SCREW	18	T1S TRS 4X12 MFZN	

* DSB-240LH

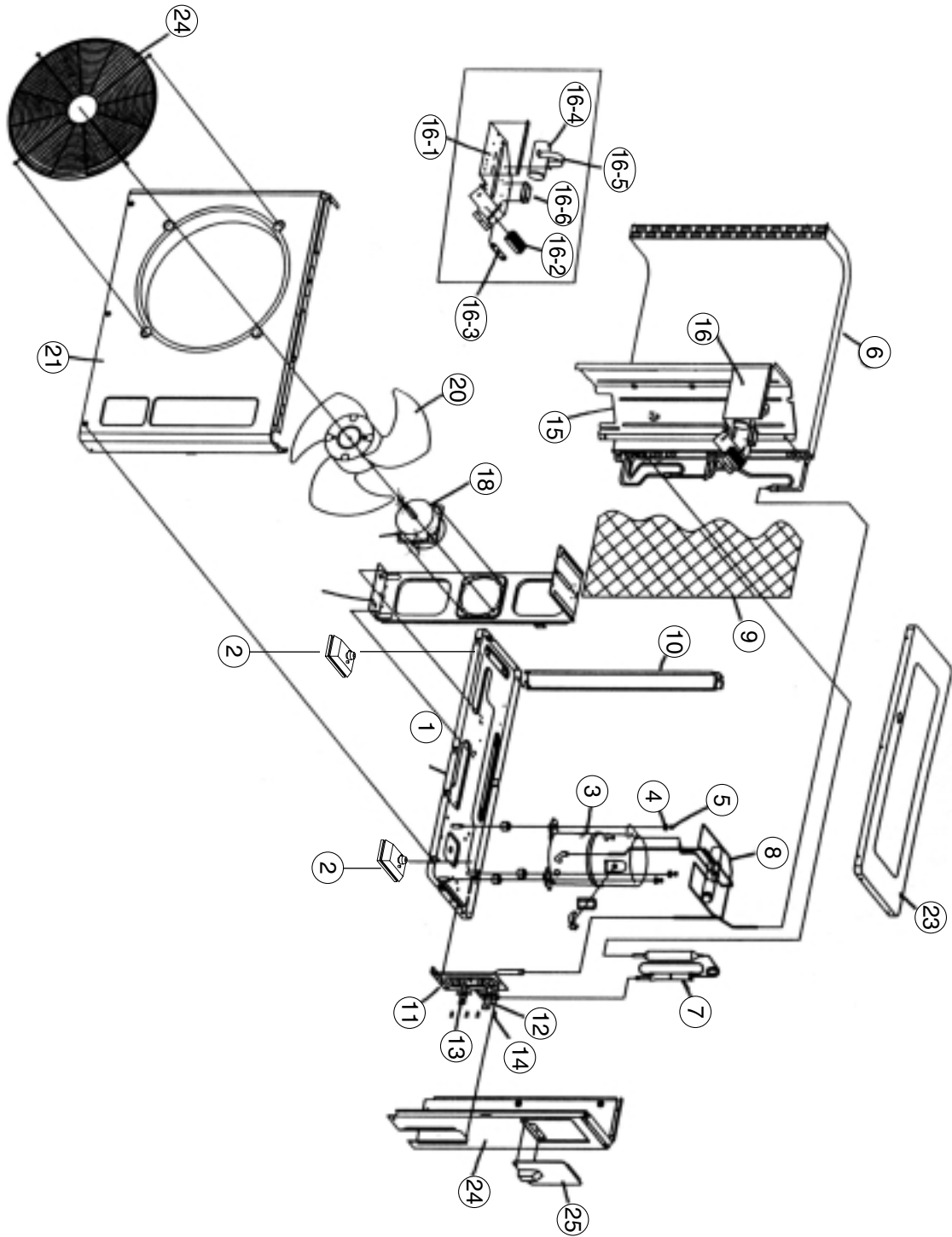

* DSB-240LH PART LIST (OUT DOOR UNIT)

✓ **Caution:** In this Service Manual, some parts can be changed for improving, their performance without notice in the parts list. So, if you need the latest parts information, please refer to PPL(Parts Price List) in Service information Center(<http://svc.dwe.co.kr>)

No	PART CODE	PART NAME	Q'TY	SPEC	REMARK
1	3100041750	BASE PAN PAINT ASSY	1	PAINTING	
2	310P30281A	FOOT CUSHION	4	NBR (54*63.5)	
3	3100068201	COMPRESSOR ASSY	1	AWG5530EXC	
4	7400208411	WASHER PLAIN	3	ID8.4*OD22*T1.6	
5	7392801211	NUT LOCK	3	M8*1.25P	
6	3100078000	CONDENSER ASSY	1	AL+CU DSB-240LH	
7	3100082900	PIPE CAPELLARY ASSY	1	C1220T H/P	
8	3100082800	PIPE REVERSING ASSY	1	C1220T-O	
9	3102402100	GRILLE COND	1	PE	
10	3100041100	GUIDE POST P/T ASSY	1	PAINTING	
11	3100041201	BRK SERVICE P/T AS	1	PAINTING	
12	3105401800	SERVICE VALVE (G)	1	Ø15.88 (5/8")	
13	3105401200	SERVICE VALVE (L)	1	Ø9.52 (3/8")	
14	3106002300	BOLT HEX	4	M6*L20 MFZN	
15	3100031702	PLT PARTITION ASSY	1	SGCC-M-Z22	
16	3100088500	ASSY PANEL CONTROL	1	SGCC-M-Z22 T0.8 H/P	
16-1	3104201601	PANEL CONTROL	1	SGCC-M-Z22 T0.8	
16-2	3108912330	TERMINAL BOLCK	1	SN-DBW-6P	
16-3	3101202000	CLAMP CORD	1	NYLON66, (VDE)	
16-4	3109508100	CAPACITOR DUAL	1	5/45MF 400VAC	
16-5	3101203300	CLAMP CAPACITOR	1	SGCC Ø63 T0.8	
16-6	5SC0202700	POWER RELAY	1	G7L-2A-TUB, 220/240V 50/60H	
17	3105300400	SUPPORT MOTOR	1	SGCC-M-Z22 T1.6	
18	3108007400	MOTOR ODU	1	OSME986DERC 230/50	
19	7348602011	BOLT HEX	4	WAS M6*L20 MFZN	
20	3101802000	FAN PROPELLER	1	ABS+G/F(20%)	
21	3100031400	CABINET FRONT P/T AS	1	PAINTING	
22	3100031500	CABINET SIDE P/T AS	1	PAINTING	
23	3100041500	PANEL TOP P/T ASSY	1	PAINTING	
24	3102102000	GRILLE DISCHARGE	1	(BE-002D)	
25	3100044250	SERVICE COVER ASSY	1	ASA	

5 CONTROL BOX ASSEMBLY

* DSB-070LH/DSB-091LH

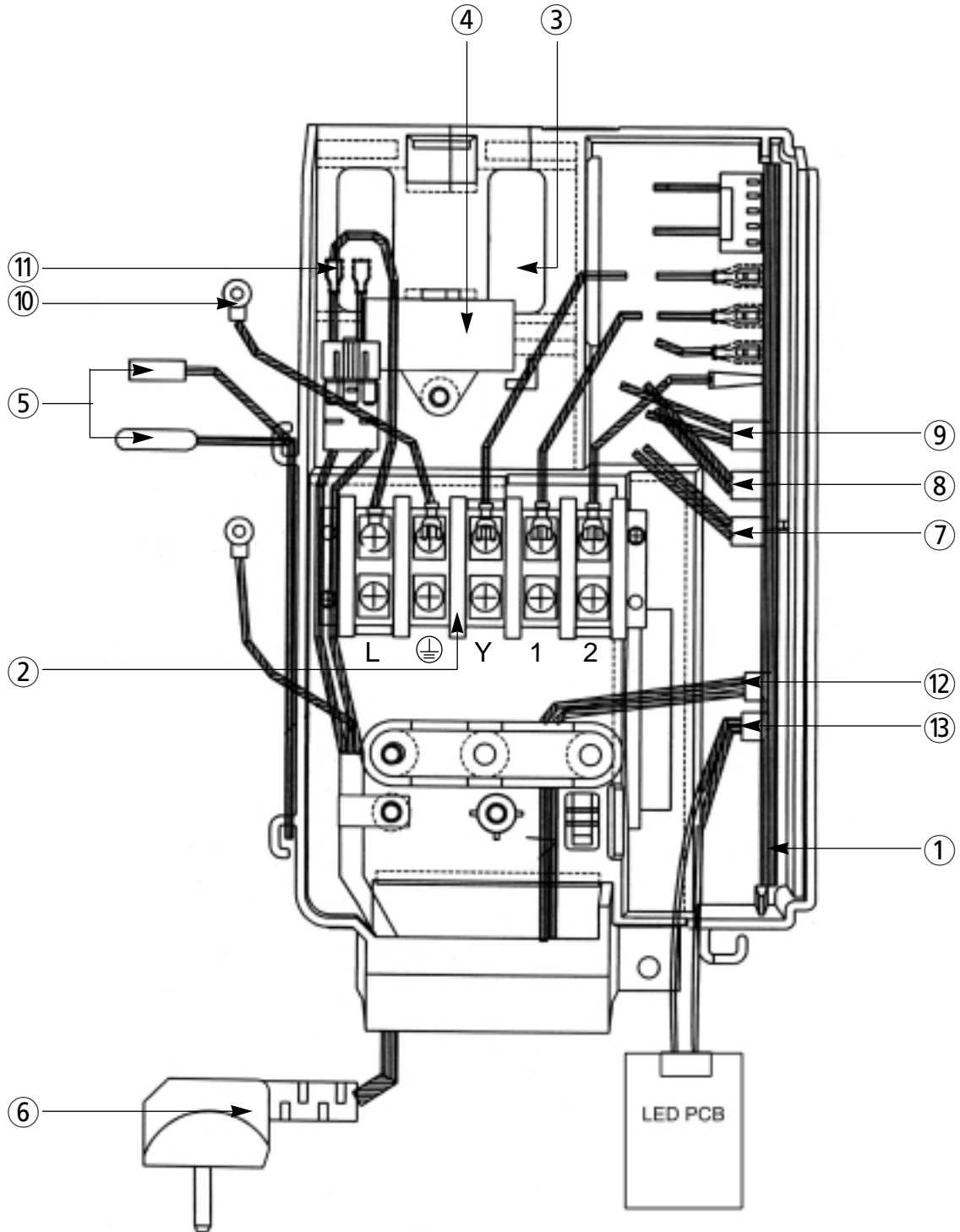

*** DSB-070LH/DSB-091LH**

✓ **Caution:** In this Service Manual, some parts can be changed for improving, their performance without notice in the parts list. So, if you need the latest parts information, please refer to PPL(Parts Price List) in Service information Center(<http://svc.dwe.co.kr>)

No	PART CODE	PART NAME	Q'TY	SPEC	REMARK
1	3100054410	CONTROL PCB ASS'Y	1		
2	3108912301	TERMINAL BLOCK	1	SN-DBW-05P 300V 25A	
3	5EPV050120	TRANSFORMER	1	DWA-220B 220V 50/60Hz	
4	3106900300	CAPACITOR SH.M.B	1	1.0 μ F 400VAC	
5	3104896300	SENSOR ID ASS'Y	1	PTM-KD43C-D2	
6	3101300100	POWER CORD ASS'Y	1	16A 250V	
7	3102797610	HARNESS	1	I/D COMP	
8	3102797150	HARNESS	1	I/D 4WAY VALVE	
9	3102704400	HARNESS	1	O/D MOTOR	
10	3102797910	HARNESS	1	I/D EARTH	
11	3102704000	HARNESS	1	POWER	
12	3102702200	HARNESS	1	TH-3-1	
13	3102704500	HARNESS	1	LED PCB	

* DSB-121LH/DSB-122LH

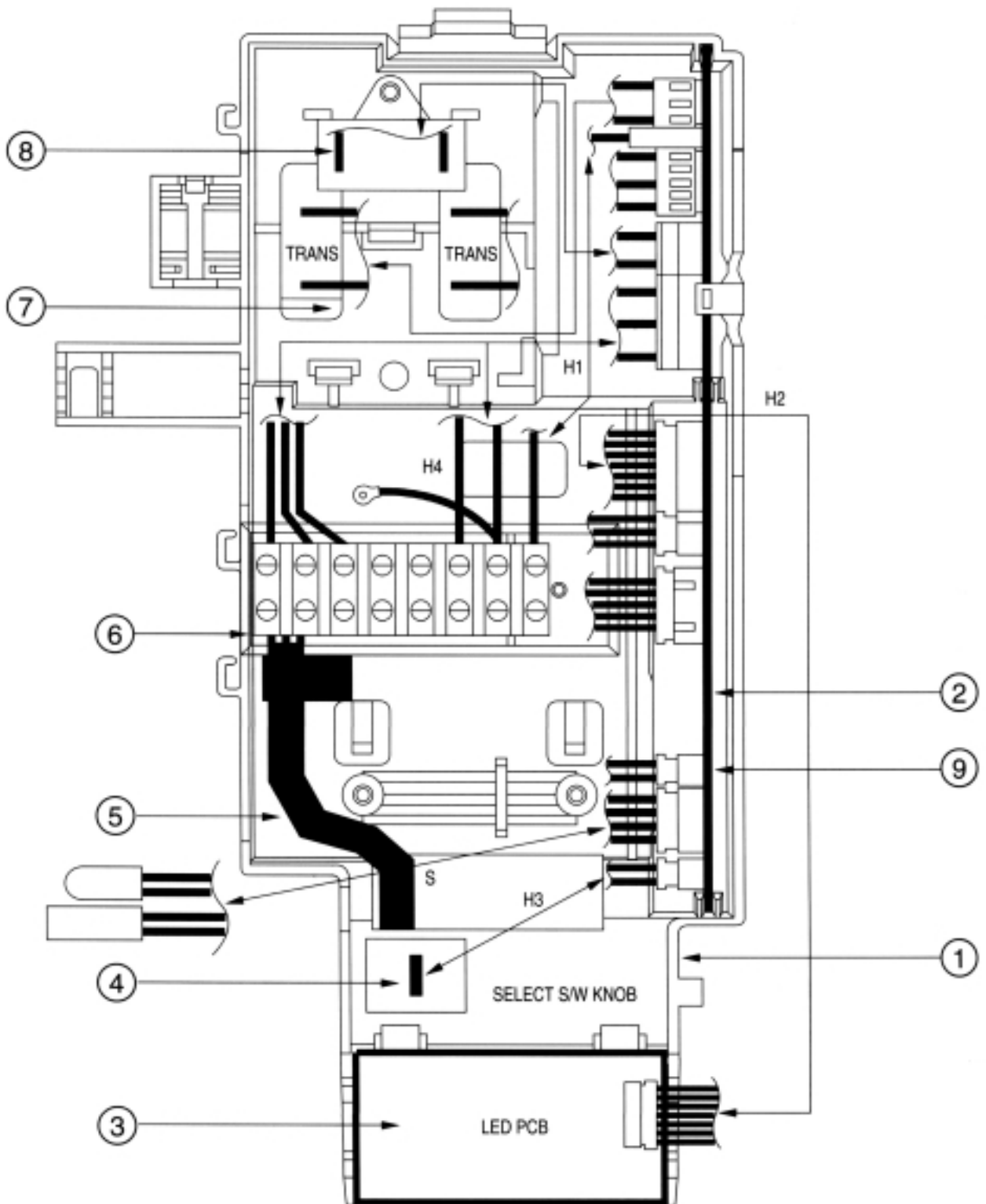

*** DSB-090LH/DSB-121LH/DSB-122LH**

✓ **Caution:** In this Service Manual, some parts can be changed for improving, their performance without notice in the parts list. So, if you need the latest parts information, please refer to PPL(Parts Price List) in Service information Center(<http://svc.dwe.co.kr>)

No	PART CODE	PART NAME	Q'TY	SPEC	REMARK
1	3100503100	CONTROL BOX	1	P.P+G.F 20%	
2	3100054400	CONTROL PCB ASS'Y	1	FR-1	
3	3100054200	LED PCB ASS'Y	1	FR-1	
4	3103400300	KNOB RESET SWITCH	1	ABS	
5	3101395060	POWER CORD ASS'Y	1		BUYER
6	3108912301	TERMINAL BLOCK	1	SN-DBW-05P	
7	5EPV050100	TRANS FORMER	1	DWA220A-50/60HZ	
8	3106900300	CAPACITOR SH.M.B	1	1.0μF 400VAC	
H1	3102797610	HARNESS I/D COMP	1		
H2	3102797500	HARNESS LED PCB	1		
H3	3102797410	HARNESS MODE SELECT	1		
H4	3102797910	HARNESS I/D EARTH	1		
S	3104896300	SENSOR ID ASS'Y	1	PTM-KD-43C-D2	
9	3102702200	HARNESS O/D SENSOR	1	6M	

* DSB-240LH

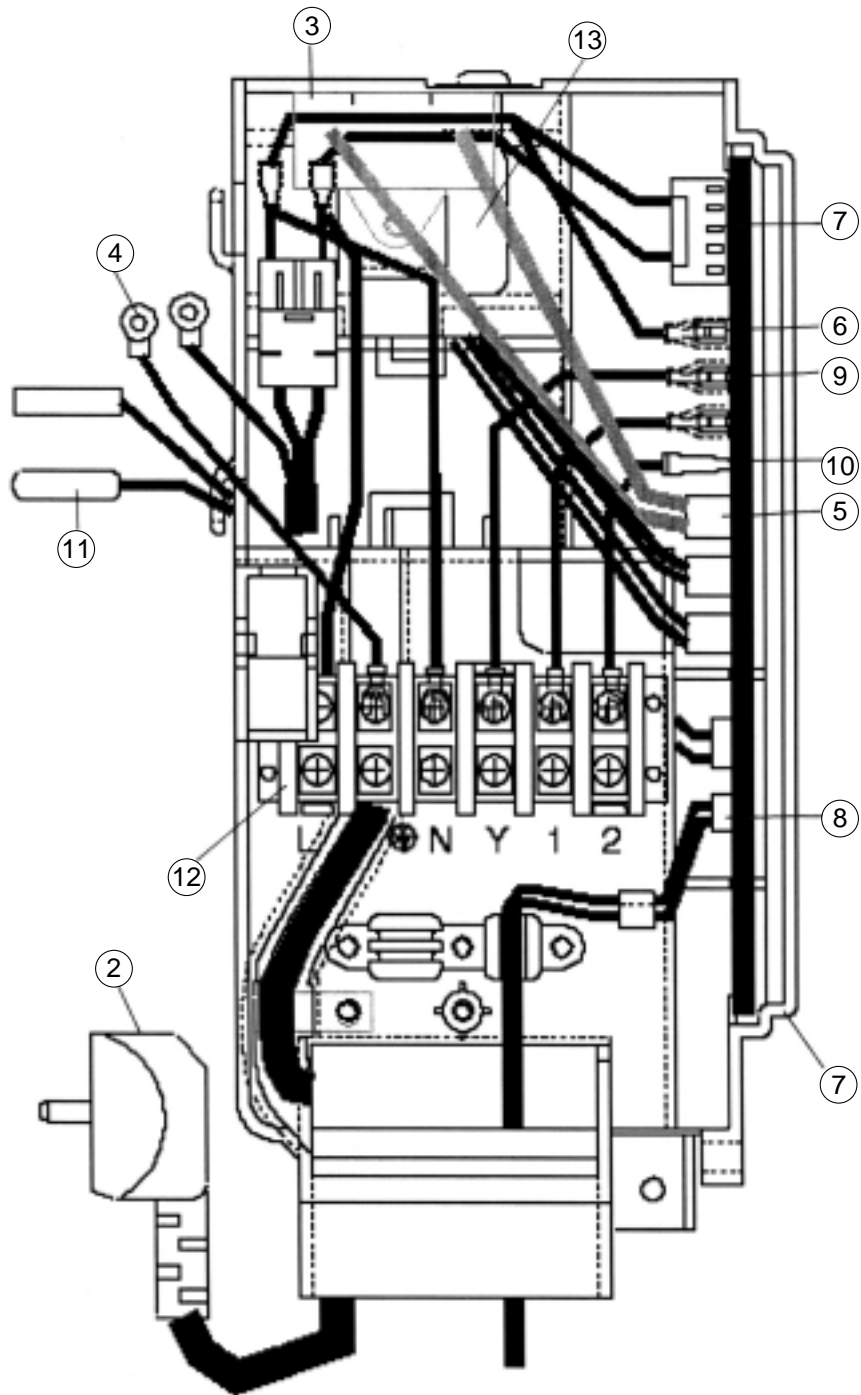

* DSB-240LH

✓ **Caution:** In this Service Manual, some parts can be changed for improving, their performance without notice in the parts list. So, if you need the latest parts information, please refer to PPL(Parts Price List) in Service information Center(<http://svc.dwe.co.kr>)

No	PART CODE	PART NAME	Q'TY	SPEC	REMARK
1	3104300830	CONTROL PCB ASS'Y	1	240LH(A), 240LH(B)	
2	3101200400	CLAMP POWER CORD	1	DA-5N	
3	3106902400	CAPACITOR SH.M.B	1	2.0MF 400V	
4	3102797910	HARNESS EARTH	1	GREEN/YELLOW L170mm	
5	3102714400	HARNESS CAPACITOR	1	DSB-240L, LH CAPACITOR	
6	3102704410	HARNESS COMP SIGNAL	1	UL1015#18	
7	3102704010	HARNESS POWER	1	UL1015#16	
8	3102702200	HARNESS TH3	1	TH-3-1	
9	3102704430	HARNESS OD SIGNAL	1	UL1015#18	
10	3102704420	HARNESS REVERSING V/	1	UL1015#18	
11	3104896300	SENSOR ID ASSY	1	NTM-KD43C-D1D2 L450, L330	
12	3108912320	TERMINAL BLOCK	1	SB-DBW-4P	
13	5EPV050120	TRANSFORMER	1	DWA-220B	

DAEWOO

DEAWOO ELECTRONICS CO., LTD

686, AHYEON-DONG MAPOGU,
SEOUL, KOREA.

C.P.O. BOX 8003 SEOUL KOREA

TELEX: DWELEC K28177-8

CABLE:"DAEWOOELEC"

FAX: +82-2-364-5588

TEL: +82-2-360-7114, 8114

<http://www.dwe.daewoo.co.kr>

PRINTED DATE: APR. 1999

S/M NO. : DSB070LH10_2