

DAEWOO

Service Manual

Refrigerator

Model: FR-251

✓ Caution

: In this Manual, some parts can be changed for improving, their performance without notice in the parts list. So, if you need the latest parts information, please refer to PPL(Parts Price List) in Service Information Center (<http://svc.dwe.co.kr>).



1. Specification	1
2. External view	2
3. Wire diagram	3
4. Name of parts	4
5. Air flow diagram	5
6. Refrigerant cycle diagram	6
7. Machine room view and part list	7
8. Main components	8
9. Door color specification	11
10. Exploded view and parts list	14

1. SPECIFICATION

MODEL NAME		FR-251
Refrigerant	R12	115g
	R134a	100g
Cooling System		Fan Cooling Convection Type
Refrigeration System		Air Forced Convection
Defrost System		Forced Fin-enanporator Type
Defrost Operation		Automatic Start & Stop
Cold Control		Adjustable Dial
Capacity	Freezer	56 ℓ
	Refrigerator	160 ℓ
	Total	216 ℓ
External Dimension	Height	1536mm
	Width	551mm
	Depth	576mm
Net Weight		51Kg

2. EXTERNAL VIEW

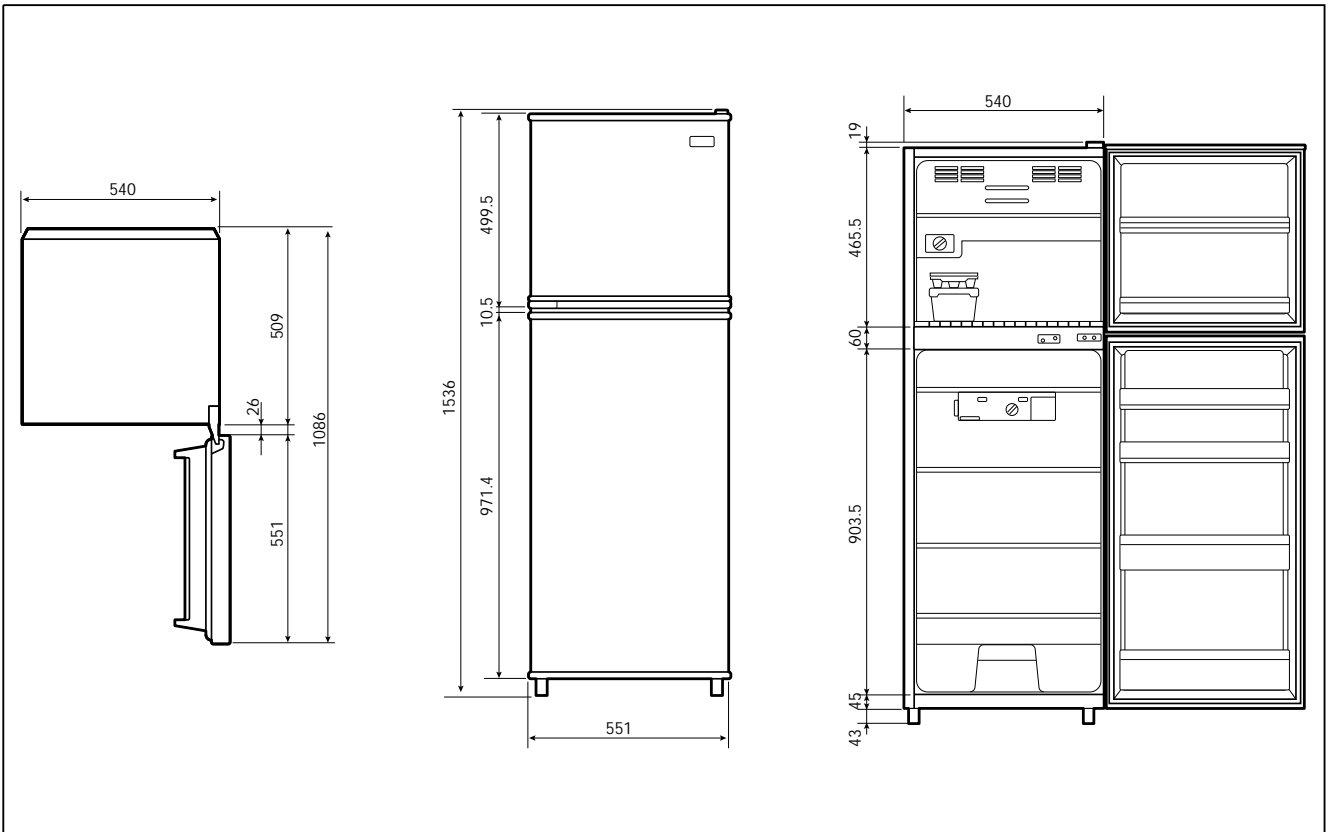

3. WIRE DIAGRAM

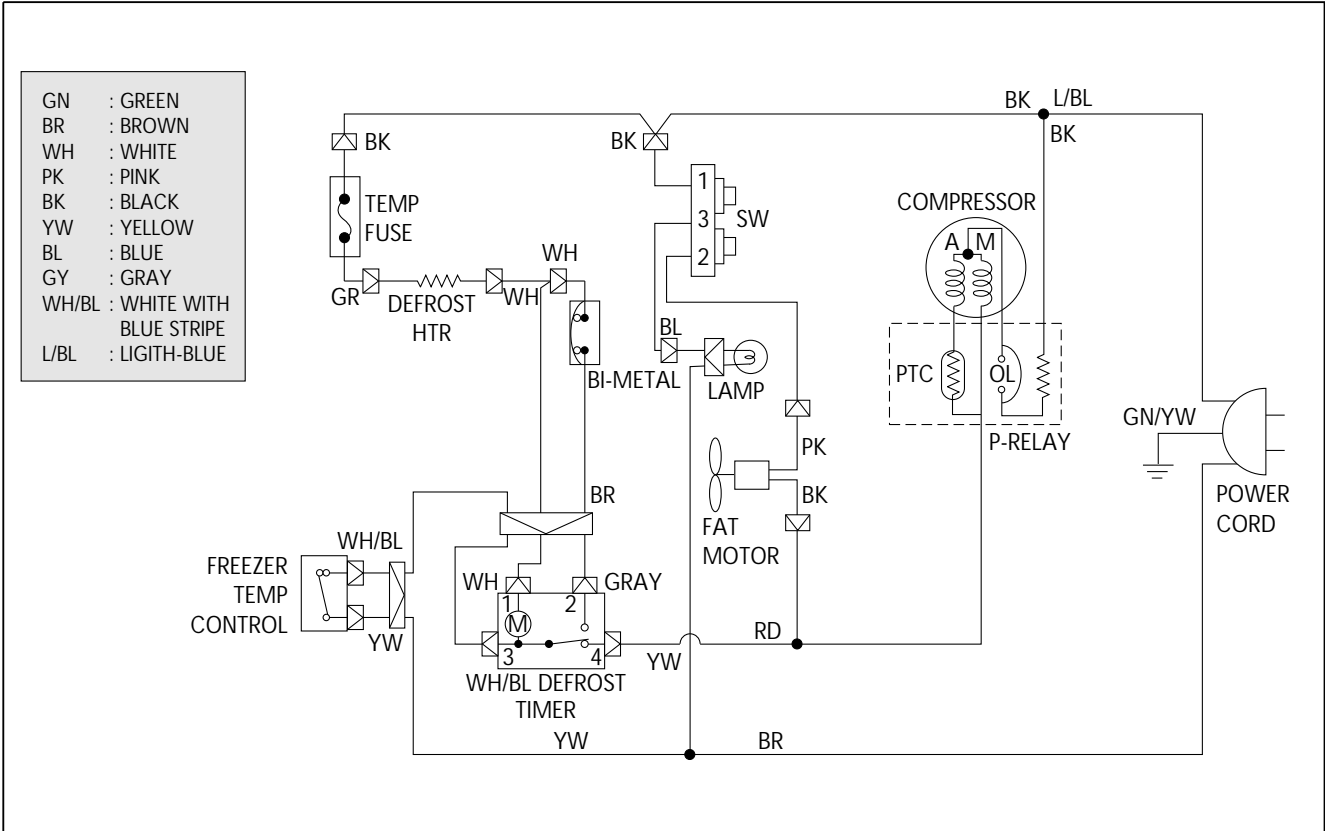

4. NAME OF PARTS

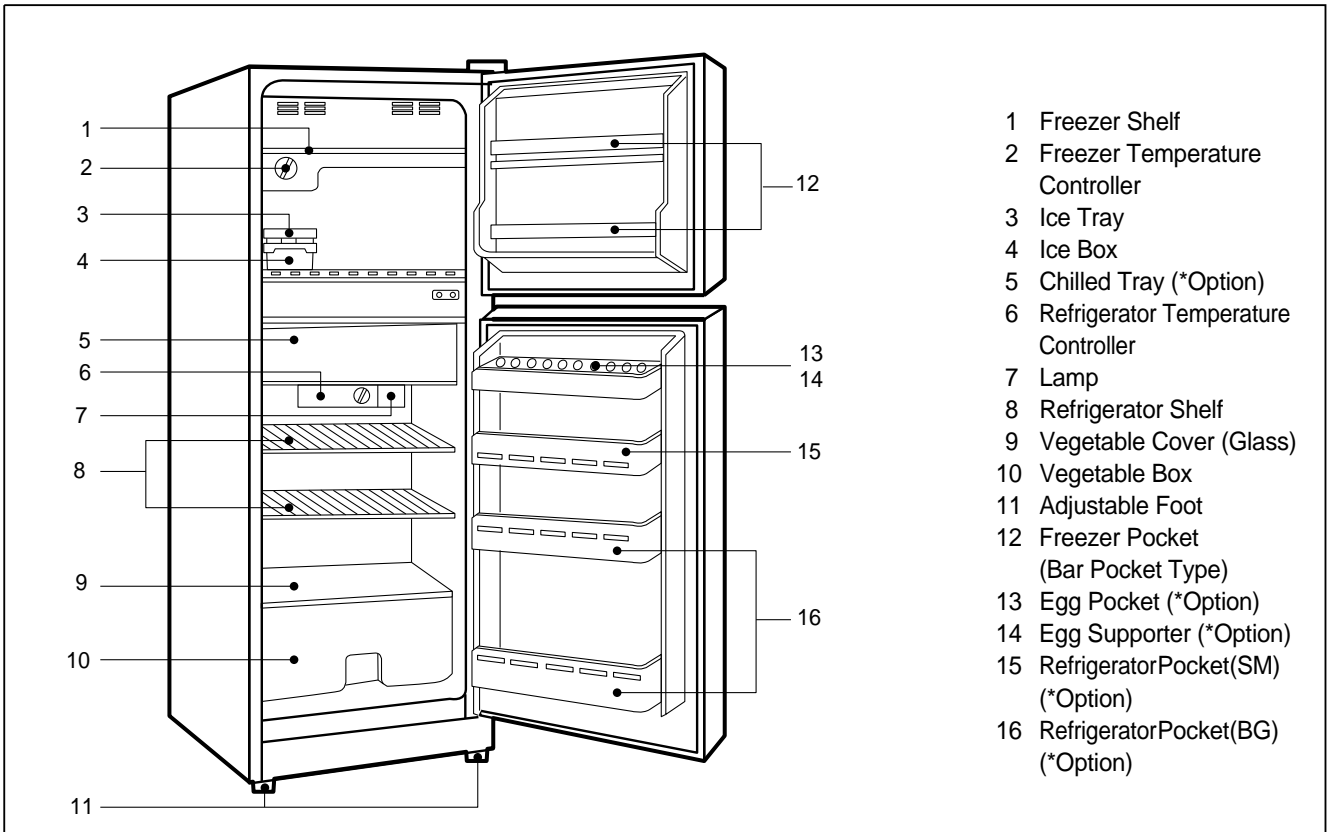

5. AIR FLOW DIAGRAM

Freezer door pocket
Do not put ice cream or frozen food in freezer door pocket to store for a long term. Opening and shutting the door can rise up the temperature.

Cold air absorbing duct
Do not place food in front of the duct because it is the entrance of the cold air.

Refrigerator door pocket
Temperature is high even if the pocket is in the middle.
When storing margarine or cheese for one or two weeks, make use of the refrigerator shelf.

Crisper
Suitable in storing fruits or vegetable.
Wrapping can prevent from dryness.

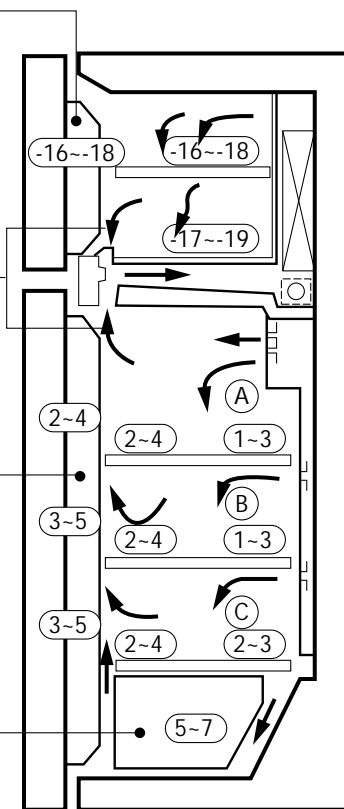

Freezer room
Do not put in any bottle such as beer or beverage because it can be frozen and broken.

Refrigerator room
This model is multi-flow type which flows out cold air from each shelf space. The hot air after making the refrigerator cold, flows into cooling system through the front upper part.

Do not put food having much moisture at the middle part of each shelf space (0A0, 0B0 and 0C0 part). It can be frozen owing to the low temperature.

6. REFRIGERANT CYCLE DIAGRAM

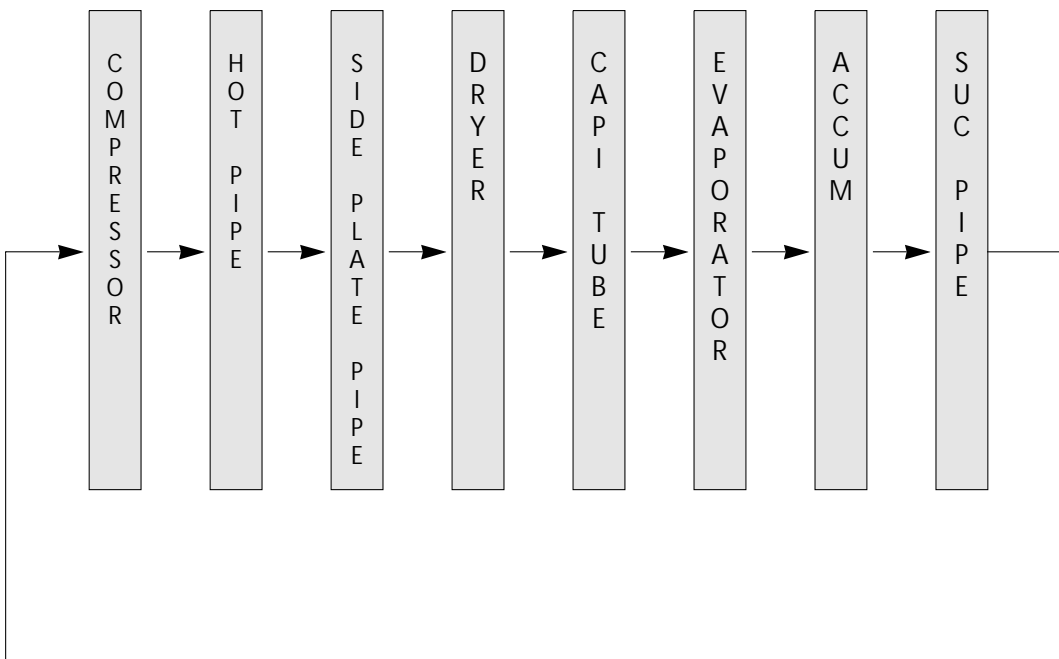
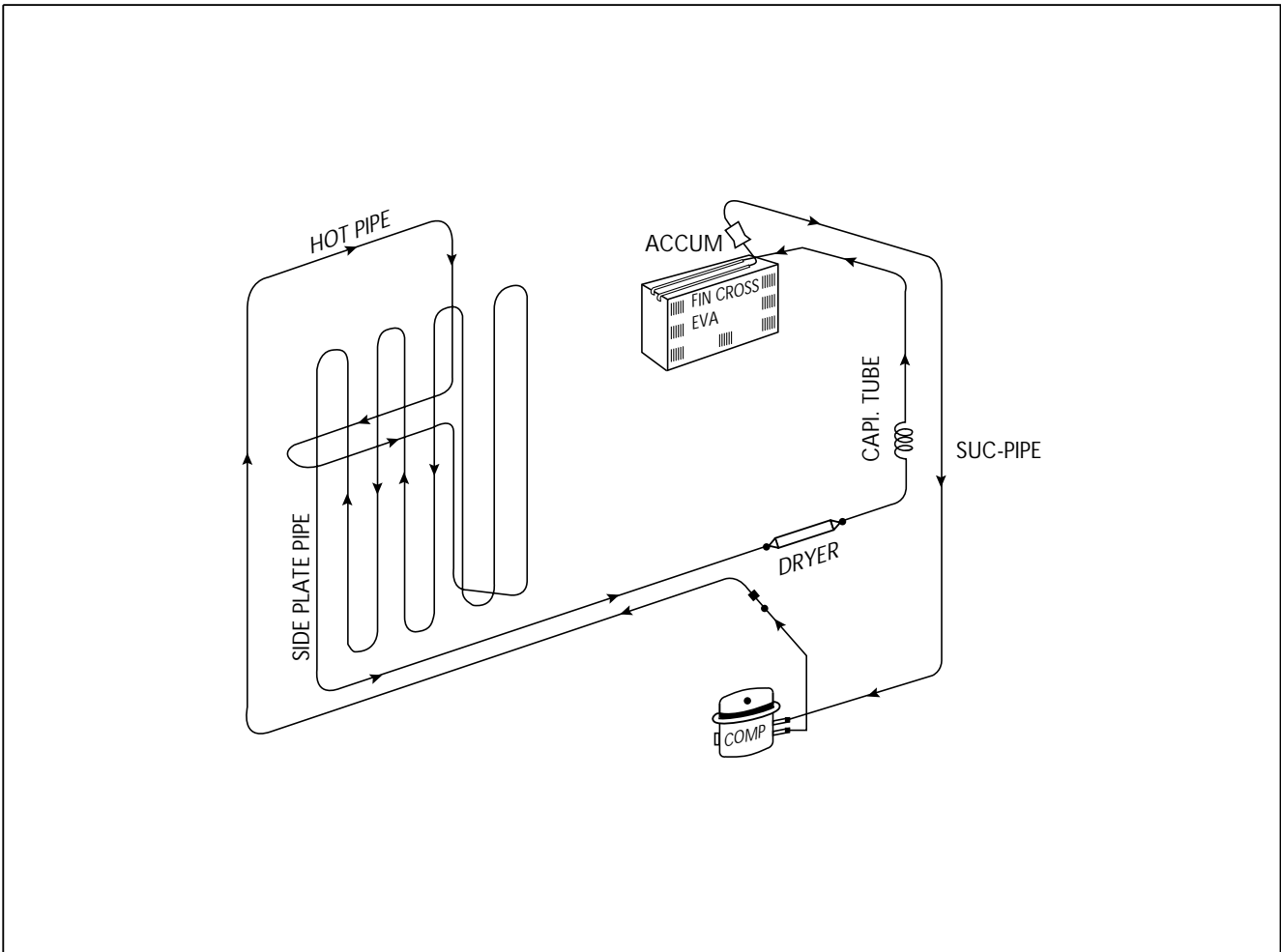

7. MACHINE ROOM VIEW AND PART LIST

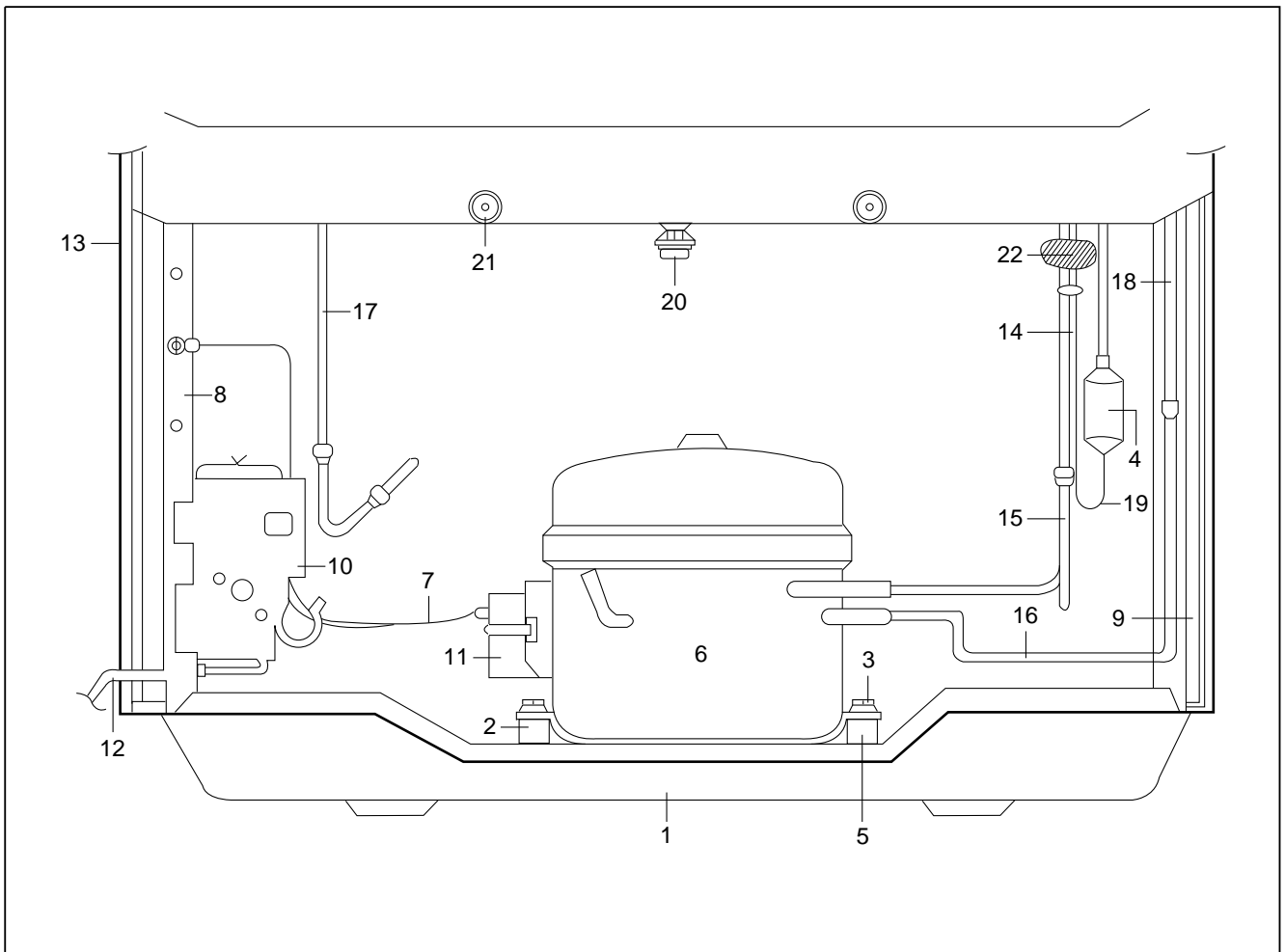

NO	PART NAME	NO	PART NAME	NO	PART NAME
1	BASE COMP	9	REINFORCE *L	17	SIDE-PLATE PIPE
2	FIXTURE BOLT COMP	10	POWER BOX AS	18	HOT-PIPE
3	WASHER	11	SWITCH P-RELAY AS	19	CAPILLARY TUBE
4	DRYER	12	POWER CORD	20	DRAIN HOSE
5	ABSORBER	13	CABINET URT AS	21	SPECIAL SCREW
6	COMPRESSOR	14	SUC-PIPE	22	VIBRATIONPROOF MASS
7	P-RELAY LEAD WIRE	15	SUC-PIPE CON		
8	REINFORCE *R	16	PIPE CON (AH)		

8. MAIN COMPONENTS

1. COMPRESSOR

Refrigerant	R12							
Voltage	100V/50,60Hz	110V/60Hz	115, 120V/60Hz	127V/60Hz	220V/50Hz	220V/60Hz	230V/50Hz	240V/50Hz
Comp. model	X	EL19J-3	X	FL19J-2	SL21YE-5	PL19J-4	SL21YE-5	←
Part code	X	3953119330	X	3951119320	3954121A50	3956119340	3954121A50	←
Strating type	X	RSCR	X	RSIR	RSIR	RSCR	RSIR	←

Refrigerant	R134a							
Voltage	100V/50,60Hz	110V/60Hz	115, 120V/60Hz	127V/60Hz	220V/50Hz	220V/60Hz	230V/50Hz	240V/50Hz
Comp. model	HEL19J	HEL19J-3	X	X	HSL23YE-5	X	HSL23YE-5	←
Part code	3953119E00	3953119E30	X	X	3954123G50	X	3954123G50	←
Strating type	RSCR	←	X	X	RSIR	X	RSIR	←

2. RELAY ASSEMBLY

Refrigerant	R12							
Voltage	100V/50,60Hz	110V/60Hz	115, 120V/60Hz	127V/60Hz	220V/50Hz	220V/60Hz	230V/50Hz	240V/50Hz
Relay model	X	232THBY-52	X	276THBY-52	197SHBY-52	129SHBY-52	197SHBY-52	←
Part code	X	3018105730	X	3018105750	3018102740	3018105202	3018102740	←

Refrigerant	R134a							
Voltage	100V/50,60Hz	110V/60Hz	115, 120V/60Hz	127V/60Hz	220V/50Hz	220V/60Hz	230V/50Hz	240V/50Hz
Relay model	427THBZZ-52	317NHBY-52	X	X	213THBY-52	X	213THBY-52	←
Part code	3018104730	3018104720	X	X	3018102770	X	3018102770	←

3. RUNNING CAPACITOR

Refrigerant	R12							
Voltage	100V/50,60Hz	110V/60Hz	115, 120V/60Hz	127V/60Hz	220V/50Hz	220V/60Hz	230V/50Hz	240V/50Hz
Spec.	X	230V/10 μ F	X	X	X	350V/5 μ F	X	X
Part code	X	400EL15130	X	X	X	400EL15110	X	X

Refrigerant	R134a							
Voltage	100V/50,60Hz	110V/60Hz	115, 120V/60Hz	127V/60Hz	220V/50Hz	220V/60Hz	230V/50Hz	240V/50Hz
Spec.	250V/16 μ F	←	X	X	X	X	X	X
Part code	3816800600	←	X	X	X	X	X	X

4. F-FAN MOTOR

Refrigerant	R12, R134a							
Voltage	100V/50,60Hz	110V/60Hz	115, 120V/60Hz	127V/60Hz	220V/50Hz	220V/60Hz	230V/50Hz	240V/50Hz
Spec.	3210DWNFQ	←	X	3210DWNFQ	3210DWNFO	3210DWNFP	3210DWNFR	←
Part code	3963220100	←	X	3963220100	4019H24102	400EL18611	3011800561	←

5. DEFROST HEATER

Refrigerant	R12, R134a							
Voltage	100V/50,60Hz	110V/60Hz	115, 120V/60Hz	127V/60Hz	220V/50Hz	220V/60Hz	230V/50Hz	240V/50Hz
Spec.	127V/110W	←	X	127V/110W	220V/110W	←	←	←
Part code	401KG73730	←	X	401KG73730	3012803000	←	←	←

6. LAMP ASSEMBLY

Refrigerant	R12, R134a							
Voltage	100V/50,60Hz	110V/60Hz	115, 120V/60Hz	127V/60Hz	220V/50Hz	220V/60Hz	230V/50Hz	240V/50Hz
Spec.	120V/15W	←	X	120V/10W	240V/13W	←	←	←
Part code	4019S15200	←	X	4019S15200	400EL20111	←	←	←

7. DEFROST TIMER

Refrigerant	R12, R134a							
Voltage	100V/50,60Hz	110V/60Hz	115, 120V/60Hz	127V/60Hz	220V/50Hz	220V/60Hz	230V/50Hz	240V/50Hz
Spec.	TMDEX09UA1	←	X	TMDEX09UA1	TMDEX09UM1	←	←	←
Part code	3018101200	←	X	3018101200	3018100310	←	←	←

8. DRYER

Refrigerant	R12	R134a
Spec.	10 g	15 g
Part code	3016800103	3016801100

POWER CORD SPECIFICATION

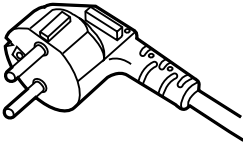
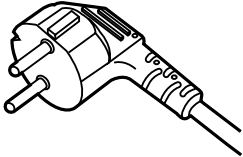
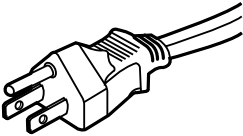
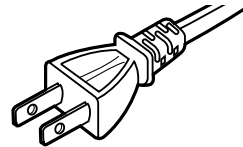
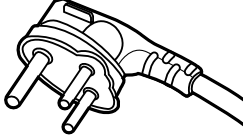
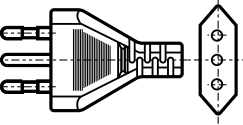
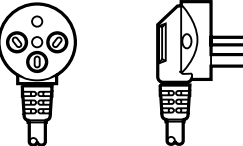
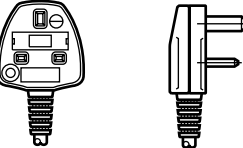
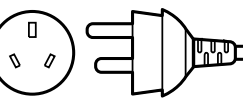
NO	SHAPE OF POWER CODE	PART CODE	DESCRIPTION	REMARK
1		3011315000	CP-2PIN	FOR EUROPEAN COUNTRY
2		401RA17200	CP-2PIN	FOR OTHER COUNTRY
3		4006D17101	KP-30	FOR AMERICA
4		401PD17101	KP-211	FOR JAPAN & TAIWAN
5		3011300801	BP-3PIN	
6		3011303010	#267	FOR CHILE
7		3011315310		FOR ISRAEL
8		3011303050	BS-1363A	FOR U.K, MIDDLE ASIA SINGAPORE & MALAYSIA
9		3011301200	KP-551/550	FOR CHINA & AUSTRALIA

* Upper power cord's part code is only for lead wire, without any kinds of terminal or housing.

9. DOOR COLOR SPECIFICATION

1. ASSEMBLY URETHAN FREEZER DOOR

1) Key type

Refrigerant	R12				R134a			
Color type	Dull lamina sheet	High glossy lamina sheet	Normal PCM	High glossy bright PCM	Dull lamina sheet	High glossy lamina sheet	Normal PCM	High glossy bright PCM
Part code	X	X	PFDT1UE120	PFDT1UE160	X	X	PFDT1UE125	PFDT1UE165

2) Non key type

Refrigerant	R12				R134a			
Color type	Dull lamina sheet	High glossy lamina sheet	Normal PCM	High glossy bright PCM	Dull lamina sheet	High glossy lamina sheet	Normal PCM	High glossy bright PCM
Part code	X	X	PFDT1UE300	PFDT1UE160	X	X	PFDT1UE305	PFDT1UE165

2. ASSEMBLY URETHAN REFRIGERATOR DOOR

1) Key type

Refrigerant	R12				R134a			
Color type	Dull lamina sheet	High glossy lamina sheet	Normal PCM	High glossy bright PCM	Dull lamina sheet	High glossy lamina sheet	Normal PCM	High glossy bright PCM
Part code	X	X	PFDU2UE360	PFDU2UE210	X	X	PFDU2UE365	PFDU2UE215

2) Non key type

Refrigerant	R12				R134a			
Color type	Dull lamina sheet	High glossy lamina sheet	Normal PCM	High glossy bright PCM	Dull lamina sheet	High glossy lamina sheet	Normal PCM	High glossy bright PCM
Part code	X	X	PFDU2UE200	PFDU2UE300	X	X	PFDU2UE205	PFDU2UE305

COLOR TABLE

1. PCM type

NO	COLOR CHIP	COLOR NAME
1		P/WITH (WH069)
2		'94 L/GRAY (GY158)
3		'95 L/GRAY (GY259)
4		'94 M/GRAY (GY331)
5		'95 M/GRAY (GY335)
6		'97 M/GRAY (GY267)
7		M. D/GRAY (GY750)
8		N/BUE (BL718)
9		MINT GREEN (GN206)
10		'97 BEIGE (BE215)

2. Lamina sheet type

NO	COLOR CHIP	COLOR NAME
1		P/WITH (WH069)
2		'94 L/GRAY (GY158)
3		'95 L/GRAY (GY259)
4		'94 M/GRAY (GY331)
5		'95 M/GRAY (GY335)
6		'97 M/GRAY (GY267)
7		M. D/GRAY (GY750)
8		N/BLUE (BL718)
9		MINT GREEN (GN206)
10		S/GOLD
11		G/GREEN

10. EXPLODED VIEW AND PARTS LIST

1. Exploded view

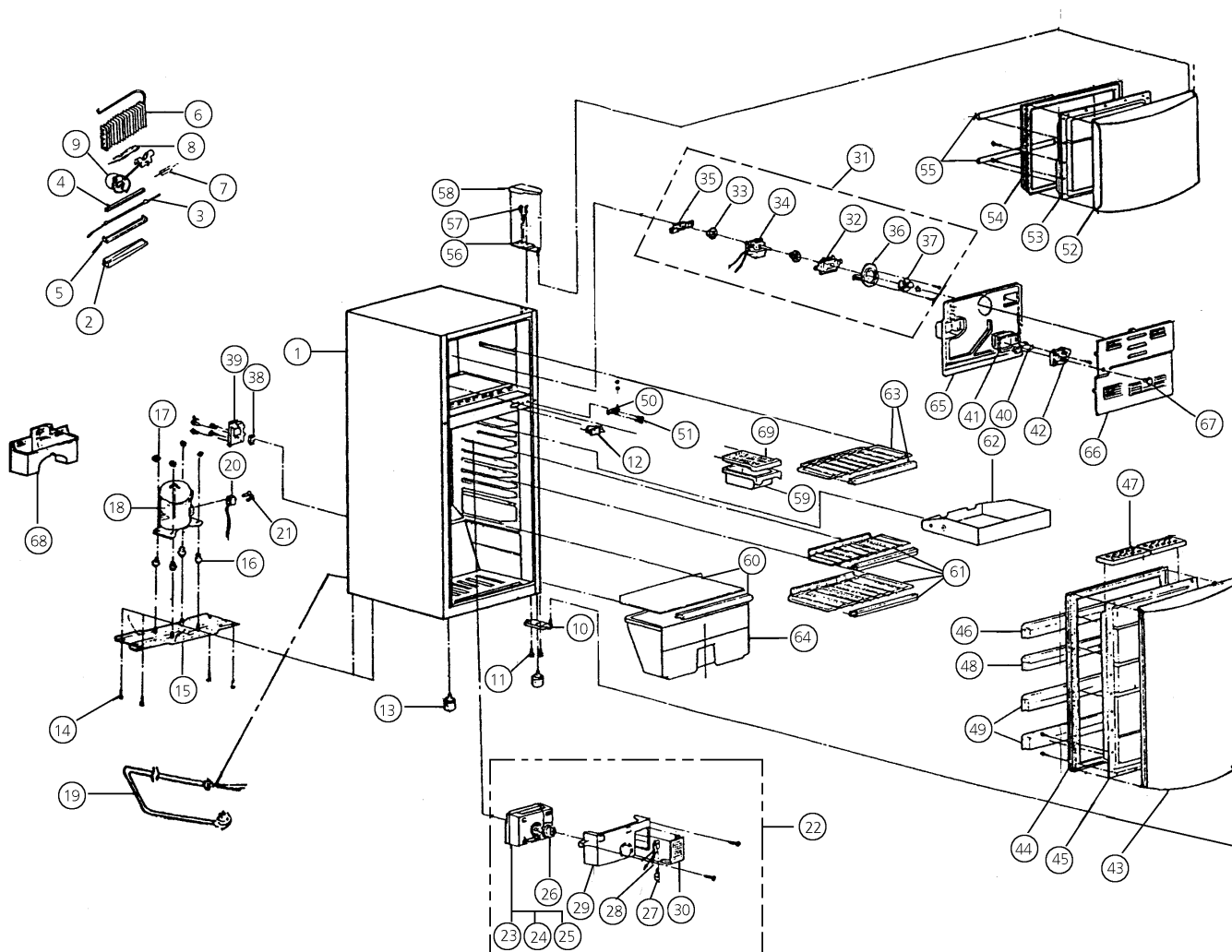

2. Parts list

✓ **Caution** : In this Service Manual, some parts can be changed for improving, their performance without notice in the parts list.
 So, if you need the latest parts information, please refer to PPL (Parts Price List) in Service Information Center
 (<http://svc.dwe.co.kr>)

NO	PART CODE	PART NAME	DESCRIPTION	QUANTITY	REMARK
1		ASSY URT CAB		1	
2	4018G57110	GUIDE DRN *O		1	
3		HEATER D AS		1	REFER TO # 9
4	4019H73570	COVER DEFR HTR *T	AL	1	
5	4019H73580	COVER DEFR HTR *U	AL	1	
6	4019H03105	EVAPORATOR AS		1	
7	3018100620	SWITCH BIMTL AS		1	
8	4019H23013	FUSE TEMP AS		1	
9	4017Z90590	FIXTURE FUSE TEMP	PP	1	
10	3012901600	HINGE *U AS	MF-ZN5-C	1	
11	7650602011	BOLT HEX	6B-1 6 X 20 HS MFZN	2	
12	3010023400	SWITCH DR AS		1	
13	4001E32531	ADJ FOOT	007-02-15	2	
14	7650602011	BOLT HEX	6B-1 6 X 20 HS MFZN	4	
15	3010303700	BASE COMP AS	Y-COMP	1	
16	3010100201	ABSORBER COMP	NR H=40	4	
17	4019H09030	SPECIAL WASHER	SWRH	4	
18		COMPRESSOR		1	REFER TO # 8
19		CORD POWER		1	REFER TO # 10
20		SWITCH P RELAY AS		1	REFER TO # 8
21	3816100100	RELAY BAND	SK-5 0.7T ZN-3-A	1	
22	4019H26001	DAMPR R ASS		1	
23	4017Z31271	INSULATOR DAMP B	F-PS	1	
24	4017G21300	DAMPER AS	D-702	1	
25	4017Z31261	INSULATOR DAMP A	F-PS	1	
26	4017Z18180	KNOB	ABS	1	
27		LAMP AS		1	REFER TO # 9
28	400EL19311	SOCKET LAMP AS	200, 200/WHITE HOUSING	1	
29	4019H22131	R DAMPER BODY	HIPS	1	
30	4017Z87570	SHADE R	HC-2	1	
31		FAN MOTR ASS		1	
32	4017Z32244	COVER FAN B	ABS	1	
33	4017Z08430	ABSORBER MOTR	EPR-B3 (H40)	1	
34		FAN MOTOR		1	REFER TO # 8
35	4017Z32230	BRACKET MOTR	ABS	1	
36	4019H32230	COVR FAN A	ABS	1	
37	4019H10310	FAN	ABS	1	
38		TIMER		1	REFER TO # 9
39	401NA29101	HOLDER DEFR TIMER	PP	1	

NO	PART CODE	PART NAME	DESCRIPTION	QUANTITY	REMARK
40	4019H14300	THEMO F	DECO B-358	1	
41	4019H27120	CONTROL BOX		1	
42	4019H27111	COVER F C/B	PP	1	
43		ASSY URT *U DOOR		1	REFER TO # 11
44	4019H47022	GASKET R DR AS	PVC-S RUBBER MAGNET	1	
45	4010X37801	LINR R DR	ABS 1.5 X 575 X 1010	1	
46	4018C37092	POCKET EGG	PVC-H	1	
47	3011106501	CASE EGG	GP T2.0	2	
48	4018N37212	POCKET MAGIC	HIPS	1	
49	4018C37051	POCKET BOTL	HIPS	2	
50	3012900611	HINGE *M AS		1	
51	3016000240	SPECIAL SCREW	M6 X 16 SWCH22A	2	
52		ASSY URT *T DOOR		1	REFER TO # 11
53	4019H46010	LINR F DR	ABS 1.5 X 558 X 1025	1	
54	4019H47012	GASKET F DR AS	PVC-S RUBBER MAGNET	1	
55	4019H30150	POCKET F	PVC-H	2	
56	3012900201	HINGE *T AS		1	
57	3016000301	SPECIAL SCREW	M5 X 14 S1018C ZN5MICRO	3	
58	3010900602	CAP *T HI	PP	1	
59	4017Z99112	CASE ICE	HC-2	1	
60	3017807300	SHELF GLAS AS	GLASS	1	
61	3017804111	SHELF R *U AS	SHELF+DEC	2	
62	4010X30401	CHILD AS		1	
63	3017804001	SHELF F AS	SHELF+DEC	1	
64	4019H30012	CASE VEGTB	HC-2	1	
65	4019H74102	INSULATOR F LUVR		1	
66	3018901000	LOUVER F AS		1	
67	4019H27131	KNOB F C/B	ABS	1	
68	4019H91113	CASE VAPORI	PP	1	
69	4017Z98110	CASE ICING	PE-HD	1	