

120

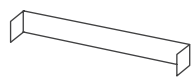

119

122

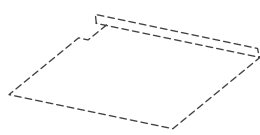

118

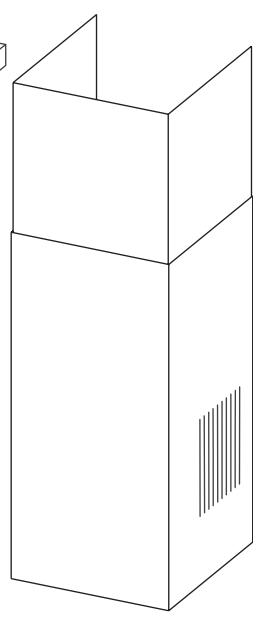

58

86

415

112

60

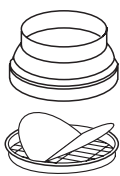

49

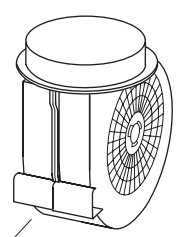
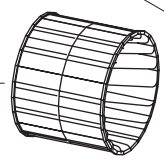

48

45

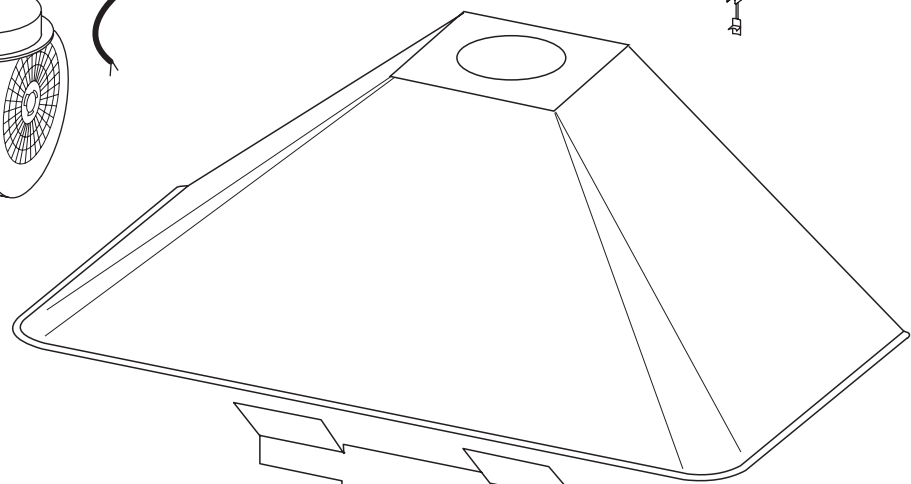

92

26



28

234

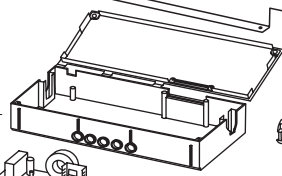

229

223

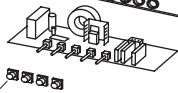

166

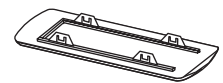

29

9

