

KENWOOD

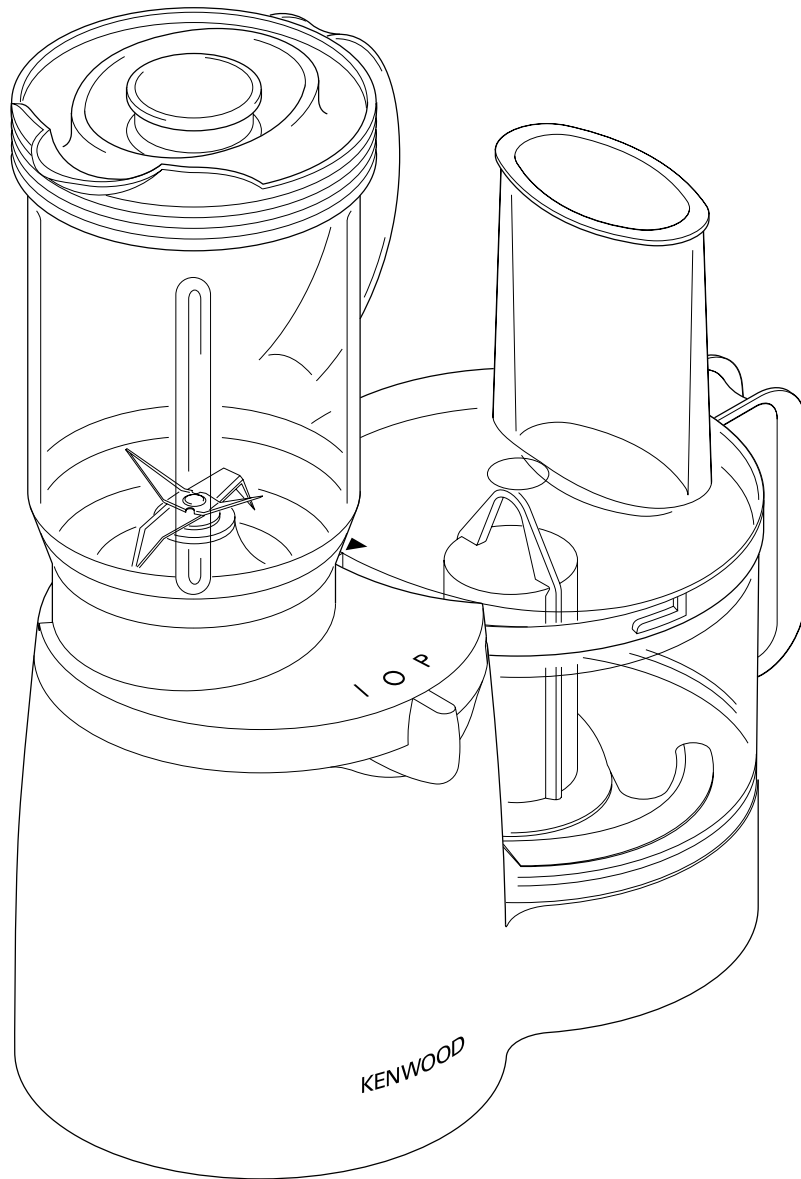

FP180 series

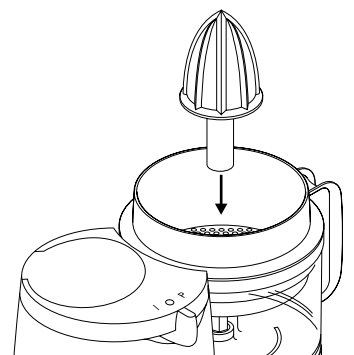
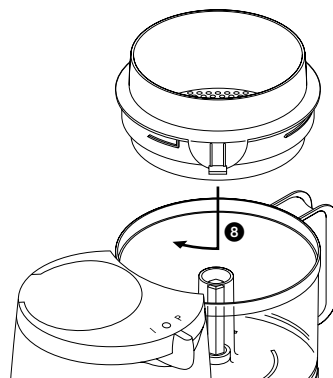
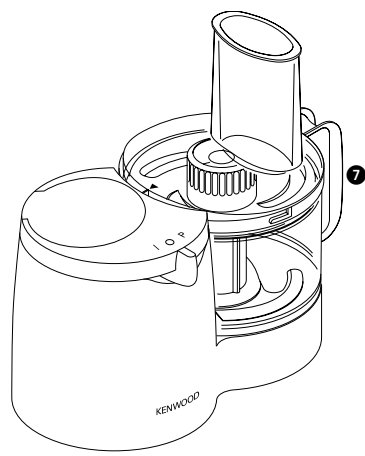
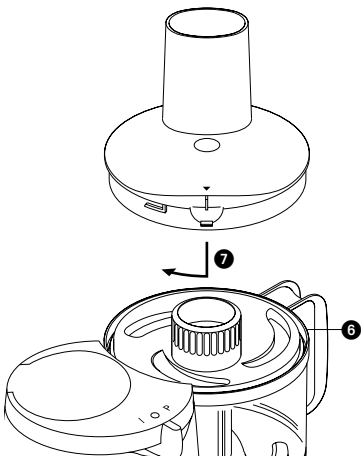
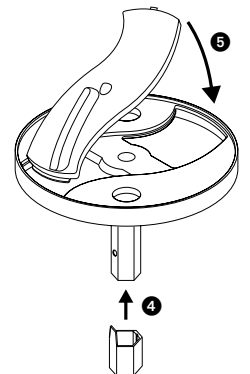
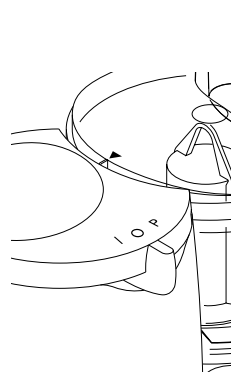
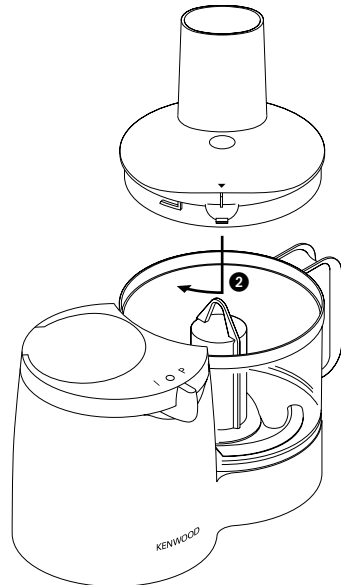
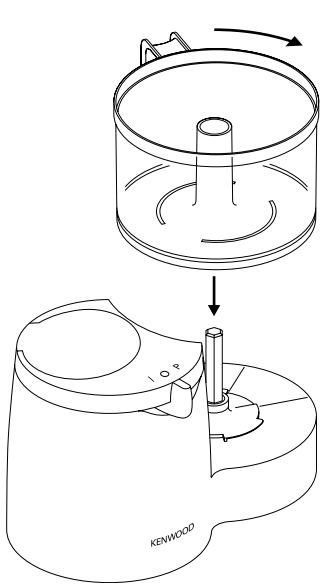
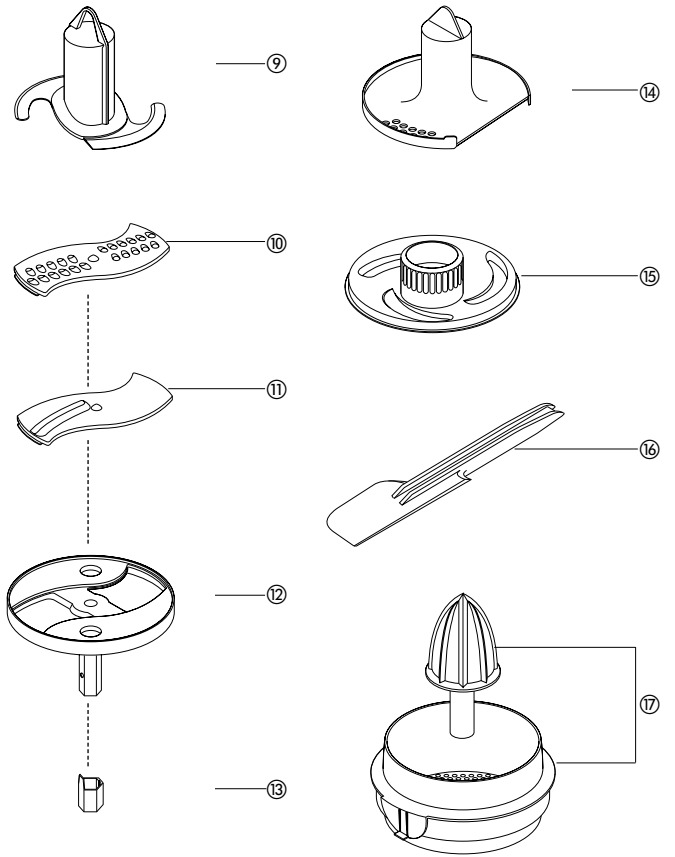
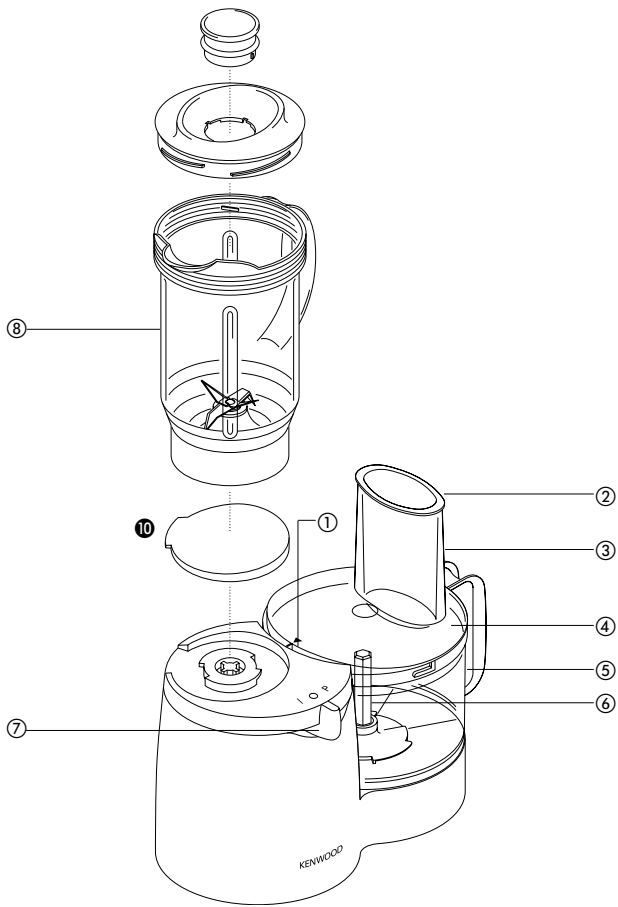

safety

- The blades and plates are very sharp, handle with care. **Always hold the knife blade by the finger grip at the top, away from the cutting edge, both when handling and cleaning.**
- Always remove the knife blade before pouring contents from the bowl.
- Keep hands and utensils out of the processor bowl and liquidiser jug whilst connected to the power supply.
- Switch off and unplug:
 - before fitting or removing parts
 - after use
 - before cleaning
- Never use your fingers to push food down the feed tube. Always use the pusher supplied.
- Before removing the lid from the bowl or liquidiser from the power unit:-
 - switch off;
 - wait until the attachment/blades have completely stopped;
- Allow hot liquids to cool before blending in the liquidiser - if you haven't fitted the lid securely and it comes off, you could get splashed.
- **This machine will be damaged and may cause injury if the interlock mechanism is subjected to excessive force.**
- **To prevent damage to the interlock mechanism:-**
 - **Always lock the bowl to the power unit before attempting to fit the lid.**
 - **Always unlock the lid before attempting to remove the bowl from the power unit.**
- This machine is not intended for use by young children or infirm persons without supervision.
- Never use an unauthorised attachment.
- Don't let children play with this machine.
- Never leave the machine on unattended.
- Never use a damaged machine. Get it checked or repaired: see 'service'.
- Never let the power unit, cord or plug get wet.
- Don't let excess cord hang over the edge of a table or worktop or touch hot surfaces.
- Never misuse your food processor and only use it for its intended domestic use.

before plugging in

- Make sure your electricity supply is the same as the one shown on the underside of your appliance.

important - UK only

- The wires in the cord are coloured as follows:
Blue = Neutral,
Brown = Live.
- This appliance complies with European Economic Community Directive 89/336/EEC.

before using for the first time

- 1 Remove all packaging including the plastic blade covers from the knife blade. These covers should be discarded as they are to protect the blade during manufacture and transit only.
- 2 Wash the parts: see 'cleaning'.
- 3 Wrap excess cord around the cord stowage at the back of the appliance.

key

- ① safety interlock
- ② pusher
- ③ feed tube
- ④ lid
- ⑤ bowl
- ⑥ food processor drive
- ⑦ on/off/pulse lever

attachments

- ⑧ liquidiser
- ⑨ knife blade
- ⑩ shredding plate
- ⑪ slicing plate
- ⑫ plate carrier
- ⑬ spacer
- ⑭ whisk
- ⑮ maxi blend canopy
- ⑯ spatula

- ⑰ Citrus press is an optional accessory and may not be included in your pack.

to use the food processor

- 1 Fit the bowl onto the processor base - handle towards the back - lower and turn clockwise until it locks firmly into place ①.
- 2 Add an attachment over the food processor drive.
 - Always fit the bowl and attachment onto the machine before adding ingredients.
- 3 Fit the lid onto the bowl - feed tube towards the back of the machine ②. Turn clockwise until the arrow on the lid aligns with the raised line on the body of the processor ③.
 - **Failure to correctly fit the lid will prevent your food processor from operating.**
- 5 Switch on by moving the on/off/pulse lever to 'I' and process until the desired consistency is achieved OR move the lever to the pulse 'P' position to operate the tool fitted to the bowl in a start/stop action. The pulse feature operates the motor and keeps it running for as long as it is held in position. This will allow you to control the texture of various foods eg when processing meat.
- 6 Switch off and reverse the above procedure to remove the bowl, lid and attachments.
 - The lid can only be removed when the on/off/pulse lever is in the 'O' position.

important

Your processor is not suitable for crushing or grinding coffee beans, spices or converting granulated sugar to caster sugar. When adding almond essence or flavouring to mixtures avoid contact with the plastic as this may result in permanent marking.

maximum capacities

egg whites	6
chopping meat	300g/10oz
shortcrust pastry flour weight	250g/9oz
yeast dough flour weight	340g/12oz
one stage sponge cake total weight	800g/1lb 12oz
soup with canopy	800ml/1.3pt
liquidiser	1 litre/1¼ pts.

using the attachments

knife blade

This blade is the most versatile of all the attachments. The texture you get is determined by the length of processing time. For coarser textures use the 'pulse' feature checking the consistency regularly.

what the knife blade can do.

Raw meat

Make 'mince' by trimming raw meat of any excess fat and cutting into 2cm $\frac{3}{4}$ in cubes, place into the bowl and operate for approximately 10 seconds or until the desired texture is achieved. The longer you run the machine the smoother the texture will be.

Cooked meat

Follow the method for raw meat but process for a shorter time.

Vegetables

Cut the vegetables into pieces approximately 2.5cm/1in in size. Process foods having a similar texture together eg harder vegetables like carrots and potatoes or softer ones like mushrooms, tomatoes or cooked vegetables.

Biscuit and breadcrumbs

Drop pieces down the feed tube whilst the machine is operating.

Shortcrust pastry and scones

Put the flour into the bowl. Use fat straight from the refrigerator and cut into 2cm/¾in cubes. Process until the mixture resembles fine breadcrumbs but take care not to overprocess. Leave the machine running and add the liquid down the feed tube. Process until one or two balls of pastry are formed. Chill before use.

Soups

Purée soups either before or after cooking. Drain the ingredients and place into the bowl with a small quantity of liquid from the recipe. Process until the desired consistency has been reached, then add to the remainder of the liquid.

Nuts

Chop nuts for cakes and biscuits by placing into the bowl and processing until the desired consistency is obtained.

Cake making

Sponge type cakes are best made by the 'all in one method'. All the ingredients are placed into the bowl and processed until smooth - approximately 10 seconds. A 'soft tub' margarine used straight from the refrigerator and cut into 2cm/¾in cubes should always be used.

Savoury dips/spreads

Place the solid ingredients into the bowl in 2.5cm/1in cubes. Process until finely chopped. Add the cream etc., and continue to process until the ingredients are well blended.

Batters

With the knife blade in position place the dry ingredients, egg and a little liquid in the bowl, process until smooth. Add the remaining liquid down the feed tube whilst the machine is operating.

Yeast dough

Place the flour, fat and other dry ingredients into the bowl and process for a few seconds to mix. With the machine running add the liquid mixture down the feed tube and continue processing until the mixture forms a dough and becomes smooth in appearance and elastic to touch - this will take 45-60 seconds. Allow the dough to rise then re-knead for 10 seconds.

whisk

Use for egg whites and cream only. The whisk is unsuitable for other recipes. Make sure the bowl and whisk are free from any traces of grease or egg yolk when whisking egg whites.

slicing and shredding plates

what the cutting plates can do.

slicing plate - slices carrots, potato, cabbage, cucumber, courgette, beetroot, onion.

shredding plate - grates cheese, carrot, potato and foods of a similar texture.

to assemble the plate carrier

- 1 Clip the spacer onto the end of the plate carrier ④.
- 2 Select the desired plate and fit into the carrier with the cutting side uppermost.
- Locate one end of the plate under the rim and press the other end into position it will only fit one way round ⑤.

important

When using the slicing and shredding plates the spacer must be clipped into position on the end of the carrier.

using the cutting plates

shredding plate

Cut pieces of food to fit the feed tube. Fill the tube almost to the top and push down using the pusher with an even pressure whilst the machine is running. Longer shreds can be obtained by stacking pieces horizontally in the feed tube eg carrot.

slicing plate

If necessary cut food to fit the feed tube. Core foods such as apples and peppers. Pack the food in an upright position in the feed tube. The height should be slightly shorter than the feed tube. Using the pusher, push down with an even pressure whilst the machine is running.

hints

- Use fresh ingredients.
- Don't cut food up too small. Fill the feed tube fairly full, this prevents food from slipping sideways during processing.

- When slicing or shredding: food placed upright comes out shorter than food placed horizontally.
- After using a cutting plate there will always be a small amount of waste on the plate or in the food.
- Do not allow food to build up to the underside of the plate - empty regularly.
- Push food down the feed tube using an even pressure.

maxi blend canopy

When blending, use the maxi blend canopy in conjunction with the knife blade. It allows you to increase the liquid processing capacity of the bowl and improve the chopping performance of the blade.

- 1 Place the canopy into the bowl over the knife blade - **do not push down** ⑥.
- 2 Fit the lid - the lid will ensure that the canopy is located at the correct height ⑦.

citrus press (optional attachment)

The citrus press is used to juice citrus fruit ie oranges, lemons, limes and grapefruits.

- 1 Fit the bowl onto the processor. Add the strainer and turn clockwise until the fin on the strainer aligns with the mark on the processor body ⑧.
- 2 Attach the cone onto the drive shaft turning until it drops all the way down ⑨.
- 3 Cut the fruit in half. Switch on and press the fruit onto the cone.

liquidiser

Use the liquidiser for fine soups, drinks and mayonnaise.

to use the liquidiser

- 1 Remove the outlet cover ⑩.
- 2 Put the ingredients into the jug.
- 3 Screw the lid and filler cap onto the jug.
- 4 Screw the jug onto the outlet.
- 5 Switch on.
- 6 After using the liquidiser always replace the outlet cover.

important

- **The liquidiser attachment will work only with the processor bowl and lid in position.**
- **When using the liquidiser outlet we recommend that there are no tools in the processor bowl.**

hints

- When making mayonnaise, put all the ingredients, except the oil into the liquidiser. Then with the machine running, pour the oil into the filler cap and let it run through.
- Thick mixtures, eg pates and dips, may need scraping down. If it's difficult to process, add more liquid.
- Allow hot liquids to cool before blending in the liquidiser – if you haven't fitted the lid securely and it comes off, you could get splashed.
- To ensure the long life of your liquidiser, never run it for longer than 60 seconds. Switch off as soon as you've got the right consistency.
- Don't process spices - they may damage the plastic.
- The machine won't work if the liquidiser is fitted incorrectly.
- Don't put dry ingredients into the liquidiser before switching on. If necessary, cut them into pieces; remove the filler cap; then with the machine running, drop them through one by one.
- Don't use the liquidiser as a storage container. Keep it empty before and after use.
- Never blend more than 1 litre (1½ pts) - less for frothy liquids like milkshakes.

cleaning

- Always switch off and unplug before cleaning.
- Never let the power unit, cord or plug get wet.
- Handle blades and cutting plates with care - they are extremely sharp.
- Some foods will discolour the plastic. This is perfectly normal. It won't harm the plastic or affect the flavour of your food. Rubbing with a cloth dipped in vegetable oil helps remove discolouring.

power unit

- Wipe with a damp cloth, then dry.
- Wrap excess cord around the cord stowage at the back of the appliance.

liquidiser

- 1 Fill with warm water, fit the lid and filler cap, then switch on for 20-30 seconds.
 - 2 Empty, then rinse. If it's still dirty, use a brush.
 - 3 Wipe, then leave to air-dry.
- Don't leave the liquidiser in water to soak. And don't leave water inside it.

other parts

- Wash by hand, then dry thoroughly.
- All attachments (except liquidiser) can be washed on the top rack of your dishwasher.

service and customer care

- If the cord is damaged it must, for safety reasons, be replaced by Kenwood or an authorised Kenwood repairer.

UK

If you need help with:

- using your appliance or
 - servicing, spare parts or repairs (in or out of guarantee)
- ☎ call Kenwood Customer Care on **023 9239 2333**. **Have your model number ready** – it's on the underside of your appliance.

Eire

See our advertisement in Golden Pages.

other countries

Contact the shop where you bought your appliance.

guarantee - UK only

If your food processor goes wrong within one year from the date you bought it, we will repair it (or replace it if necessary) free of charge provided:

- you have not misused, neglected or damaged it;
- it has not been modified (unless by Kenwood);
- it is not second-hand;
- it has not been used commercially;
- you have not fitted a plug incorrectly; and
- **you supply your receipt to show when you bought it.**

This guarantee does not affect your statutory rights.

recipes

mackerel pâté

200g/8oz smoked mackerel cut into 2cm $\frac{3}{4}$ in cubes
100g/4oz cream cheese cut into 2cm $\frac{3}{4}$ in cubes
few drops of lemon juice
salt and pepper } optional

Fit the knife blade in the bowl, add all the ingredients and blend until smooth.

shortcrust pastry

250g/9oz plain flour
125g/4 $\frac{1}{2}$ oz mixture of lard and margarine, cut into 2cm $\frac{3}{4}$ in cubes, taken straight from the refrigerator
pinch salt
45ml/9tsp water

Fit the knife blade to the bowl, add the flour, fat and salt. Process until the mixture resembles fine breadcrumbs (approximately 6 seconds - don't overprocess as it will continue mixing when the water is added.)

With the machine running add the water down the feed tube and process until one or two balls of pastry are formed. Remove the pastry from the bowl and gather together by hand to prevent overprocessing. Wrap in cling film and chill for 30 minutes before using.

beef cobbler

450g/1lb lean braising steak, cut into 2.5cm/1in cubes
1 onion, peeled
25g/1oz butter
400g tin chopped tomatoes
125g/4 $\frac{1}{2}$ oz mushrooms, wiped
2.5ml/ $\frac{1}{2}$ tsp mixed herbs
salt and pepper

topping

200g/8oz self raising flour
75g/3oz suet
50g/2oz cheddar cheese
90ml/6tbsp water approximate

With the knife blade in position separately chop the onion, mushrooms and meat (chop the meat in two batches). Melt the butter add the onion and meat and fry for approximately 10 minutes. Add the tomatoes, mushrooms and seasoning and simmer gently for approximately 20 minutes. Transfer the mixture to an ovenproof dish.

Grate the cheese. Place the knife blade in position, add the cheese, flour and suet. Mix together then with the motor running add sufficient water down the feed tube to make a firm dough. Roll out on a lightly floured surface to approximately 1cm $\frac{3}{4}$ in thick and cut out circles using a 6cm/2 $\frac{1}{2}$ in cutter. Arrange the scones on top of the meat overlapping slightly. Brush with milk then bake at 200°C, 400°F or gas mark 6 for 30 minutes.

layered salad

1/4 small white cabbage, stalk removed
1/2 small red cabbage, stalk removed
1/2 cucumber
2 eating apples, cored
2 carrots, peeled
100g/4oz cheddar cheese
50g/2oz walnuts

Separately slice the cabbage, cucumber and apples then place in layers in a salad bowl. Separately grate the carrot and cheese and add in layers to the bowl. Using the knife blade chop the walnuts and sprinkle on top of the salad. Serve with your favourite salad dressing.

victoria sandwich

150g/6oz 'soft tub' margarine, cut into 2cm/¾in cubes, taken straight from the refrigerator
150g/6oz caster sugar
3 eggs
150g/6oz self raising flour
jam
icing sugar

Using the knife blade, place the margarine, sugar, eggs and flour into the bowl. Process for a few seconds (approximately 5-8 seconds) until smooth. Place the mixture into two greased 18cm/7in sandwich tins and bake in a pre-heated oven at 190°C/375°F/gas mark 5 for approximately 25 minutes until golden and springs back when lightly touched. Turn onto a wire rack and allow to cool, then sandwich together with jam and dredge with icing sugar.

white bread

300g/10oz strong white plain flour
5ml/1tsp salt
6g/¼oz lard
15g/½oz fresh yeast or 10ml/2tsp dried active yeast plus 5ml/1tsp sugar
175ml/6fl.oz warm water

dried active yeast

Sprinkle the dried yeast into the warm water, add the sugar and allow to stand for approximately 10 minutes or until the mixture is frothy.

fresh yeast

Crumble into the bowl with the flour.

other types of yeast

Follow the manufacturers instructions.

With the knife blade in the bowl, add the flour, salt, lard (fresh yeast if used) and process for a few seconds to evenly distribute the ingredients throughout the flour. With the machine operating, quickly pour the water or yeast liquid in a steady stream through the feed tube (this should take about 10 seconds). Continue processing until the mixture forms a dough and becomes smooth in appearance and elastic to the touch, this will take about 45 seconds. Remove the dough into either a greased polythene bag or a lightly floured bowl and cover. Leave this dough in a warm place until doubled in size. Return the risen dough to the processor bowl fitted with the knife blade and re-knead for about 10 seconds. Shape the dough into a loaf or about 15 rolls and place on greased baking trays and leave until double in size. Bake at 230°C/450°F/gas mark 8 for 20-25 minutes for a loaf or 10-15 minutes for bread rolls. When the loaf or rolls are cooked they should sound hollow when tapped on the base.

winter warmer soup

carrots, potatoes and onions:
fifteen 2 cm cubes of each
bacon stock
75g red lentils, washed
190ml vegetable stock
one 300g tin chopped tomatoes
salt and pepper
150g cooked bacon joint cut into 1 cm cubes

Put the carrot, potato and onions into the blender in that order. Add bacon stock up to the 0.75L mark. Blend for no more than 5 seconds. Pour into a saucepan. Then add the lentils, tomatoes, vegetable stock and seasoning. Bring to the boil, stirring constantly. Then simmer for about 1 hour, stirring regularly, until the ingredients are cooked. Add the bacon cubes and heat through for 5 minutes. Serve immediately.



Kenwood Limited, New Lane, Havant, Hampshire PO9 2NH, UK
www.kenwood.co.uk