



Website:<http://biz.LGservice.com>
E-mail:<http://www.LGService.com/techsup.html>

COLOR MONITOR SERVICE MANUAL

CHASSIS NO. : CL-32

MODEL: FLATRON L1510B (L1510BL-AL**R)

() **Same model for SVC

CAUTION

BEFORE SERVICING THE UNIT,
READ THE **SAFETY PRECAUTIONS** IN THIS MANUAL.

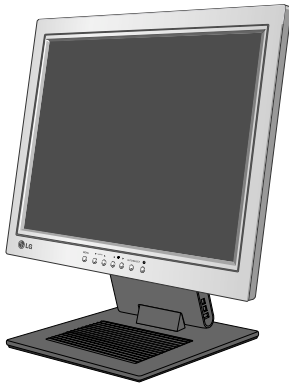

CONTENTS

SPECIFICATIONS	2	ADJUSTMENT	11
PRECAUTIONS	3	TROUBLESHOOTING GUIDE	12
TIMING CHART	4	PRINTED CIRCUIT BOARD.....	16
OPERATING INSTRUCTIONS	5	EXPLODED VIEW.....	18
WIRING DIAGRAM	8	REPLACEMENT PARTS LIST	21
BLOCK DIAGRAM	9	PIN CONFIGURATION.....	24
DESCRIPTION OF BLOCK DIAGRAM	10	SCHEMATIC DIAGRAM.....	26

SPECIFICATIONS

1. LCD CHARACTERISTICS

Type : TFT XGA LCD Module
 Size : 331.0(H) x 257.9(V) x 11.0(D)
 Pixel Pitch : 0.297mm x 0.297mm
 Color Depth : 6bits(with FRC)/ 16M colors
 Active Video Area : 15.0inch
 (304.128 x 228.096)
 Surface Treatment : Anti-Glare, Hard Coating (3H)
 Backlight Unit : Top/Bottom edge side 2CCFL
 Electrical Interface : LVDS interface

2. OPTICAL CHARACTERISTICS

2-1. Viewing Angle by Contrast Ratio ≥ 10
 Left : 55° min. Right : 55° min.
 Top : 40° min. Bottom : 40° min.

2-2. Luminance
 : 200(min.), 250(typ.) at Center point

2-3. Contrast Ratio :250(min.), 350(typ.)

3. SIGNAL (Refer to the Timing Chart)

3-1. Sync Signal
 1) Type : Separate Sync. (Horizontal & Vertical)
 2) Input Voltage Level: Low=0~0.8V, High=2.1~5.5V
 3) Sync Polarity : Positive or Negative

3-2. Video Input Signal
 1) Type : R, G, B Analog
 2) Voltage Level : 0~0.714 V
 a) Color 0, 0 : 0 Vp-p
 b) Color 7, 0 : 0.467 Vp-p
 c) Color 15, 0 : 0.714 Vp-p
 3) Input Impedance : 75 Ω

3-3. Operating Frequency
 Horizontal : 30 ~ 63kHz
 Vertical : 56 ~ 75Hz

4. POWER SUPPLY

4-1. Power
 100~240V, 50/60Hz 0.6A

4-2. Power Consumption

MODE	H/V SYNC	VIDEO	POWER CONSUMPTION	LED COLOR
POWER ON (MAX)	ON/ON	ACTIVE	less than 30 W	GREEN
POWER ON (NORMAL)	ON/ON	ACTIVE	less than 25 W	GREEN
STAND-BY	OFF/ON	OFF	less than 3 W	AMBER
SUSPEND	ON/OFF	OFF	less than 3 W	AMBER
DPM OFF	-	-	less than 3 W	AMBER

5. ENVIRONMENT

5-1. Operating Temperature: 10°C~35°C (50°F~95°F)
 (Ambient)
 5-2. Relative Humidity : 10%~80%
 (Non-condensing)
 5-3. MTBF : 50,000 Hours (Min.)
 Lamp Life : 40,000 Hours (Min.)

6. DIMENSIONS (with TILT/SWIVEL)

Width : 356mm (14.01")
 Depth : 229mm (9.01")
 Height : 380mm (14.96")



Width : 356mm (14.01")
 Depth : 291.4mm (11.47")
 Height : 103.3mm (4.06")

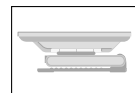

7. WEIGHT (with TILT/SWIVEL)

Net. Weight : 5.1kg (11.24 lbs)
 Gross Weight : 6.6kg (14.55 lbs)

PRECAUTION

WARNING FOR THE SAFETY-RELATED COMPONENT.

- There are some special components used in LCD monitor that are important for safety. **These parts are marked  on the schematic diagram and the replacement parts list.** It is essential that these critical parts should be replaced with the manufacturer's specified parts to prevent electric shock, fire or other hazard.
- Do not modify original design without obtaining written permission from manufacturer or you will void the original parts and labor guarantee.

TAKE CARE DURING HANDLING THE LCD MODULE WITH BACKLIGHT UNIT.

- Must mount the module using mounting holes arranged in four corners.
- Do not press on the panel, edge of the frame strongly or electric shock as this will result in damage to the screen.
- Do not scratch or press on the panel with any sharp objects, such as pencil or pen as this may result in damage to the panel.
- Protect the module from the ESD as it may damage the electronic circuit (C-MOS).
- Make certain that treatment person's body are grounded through wrist band.
- Do not leave the module in high temperature and in areas of high humidity for a long time.
- The module not be exposed to the direct sunlight.
- Avoid contact with water as it may a short circuit within the module.
- If the surface of panel become dirty, please wipe it off with a softmaterial. (Cleaning with a dirty or rough cloth may damage the panel.)

WARNING

BE CAREFUL ELECTRIC SHOCK !

- If you want to replace with the new backlight (CCFL) or inverter circuit, must disconnect the AC adapter because high voltage appears at inverter circuit about 650Vrms.
- Handle with care wires or connectors of the inverter circuit. If the wires are pressed cause short and may burn or take fire.

CAUTION

Please use only a plastic screwdriver to protect yourself from shock hazard during service operation.

TIMING CHART

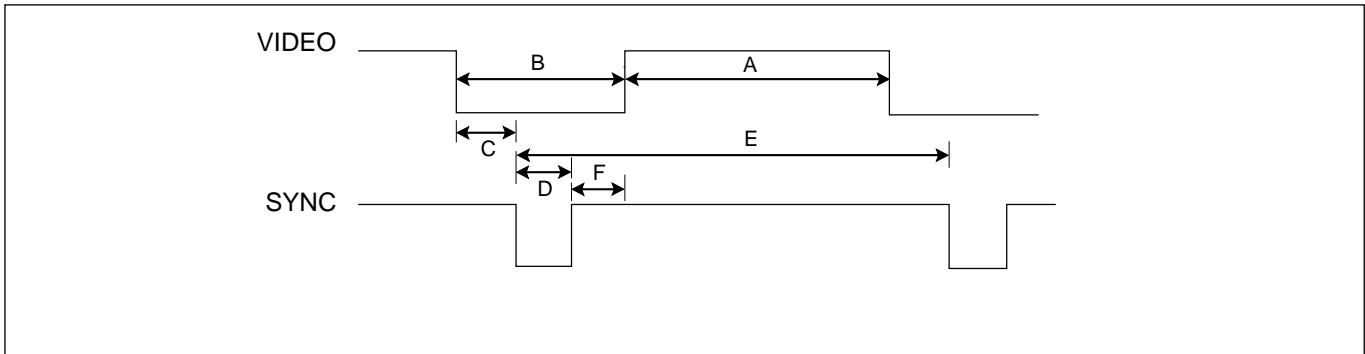

MODE	H / V	Sync Polarity	Dot Clock	Frequency	Total Period (E)	Video Active Time (A)	Blanking Time (B)	Sync Duration (D)	Back Porch (F)	Front Porch (C)	Resolution
1	H (Pixels)	+	25.175	31.468 KHz	800	640	160	96	48	16	640 x 350
	V (Lines)	-		70.0 Hz	449	350	99	2	60	37	
2	H (Pixels)	-	28.322	31.468 KHz	900	720	180	108	55	17	720 x 400 (TEXT)
	V (Lines)	+		70.0 Hz	449	400	49	2	34	13	
3	H (Pixels)	-	25.175	31.469 KHz	800	640	160	96	48	16	640 x 480
	V (Lines)	-		60.0 Hz	525	480	45	2	33	10	
4	H (Pixels)	-	30.24	35.00 KHz	864	640	224	64	96	64	640 x 480
	V (Lines)	-		66.67 Hz	525	480	45	3	39	3	
5	H (Pixels)	-	31.5	37.861 KHz	832	640	192	40	128	24	640 x 480
	V (Lines)	-		72.8 Hz	520	480	40	3	28	9	
6	H (Pixels)	-	31.5	37.50 KHz	840	640	200	64	120	16	640 x 480
	V (Lines)	-		75.0 Hz	500	480	20	3	16	1	
7	H (Pixels)	+	36.0	35.156KHz	1024	800	224	72	128	24	800 x 600
	V (Lines)	+		56.25 Hz	625	600	25	2	22	1	
8	H (Pixels)	+	40.0	37.879 KHz	1056	800	256	128	88	40	800 x 600
	V (Lines)	+		60.3 Hz	628	600	28	4	23	1	
9	H (Pixels)	+	50.0	48.077 KHz	1040	800	240	120	64	56	800 x 600
	V (Lines)	+		72.188 Hz	666	600	66	6	23	37	
10	H (Pixels)	+	49.5	46.875 KHz	1056	800	256	80	160	16	800 x 600
	V (Lines)	+		75.0 Hz	625	600	25	3	21	1	
11	H (Pixels)	-	57.2832	49.725 KHz	1152	832	320	64	224	32	832 x 624 (MAC)
	V (Lines)	-		74.55 Hz	667	624	43	3	39	1	
12	H (Pixels)	-	65	48.363 KHz	1344	1024	320	136	160	24	1024 x 768
	V (Lines)	-		60.0 Hz	806	768	38	6	29	3	
13	H (Pixels)	-	75	56.476 KHz	1328	1024	304	136	144	24	1024 x 768
	V (Lines)	-		70.0 Hz	806	768	38	6	29	3	
14	H (Pixels)	+	78.75	60.023 KHz	1312	1024	288	96	176	16	1024 x 768
	V (Lines)	+		75.0 Hz	800	768	32	3	28	1	

OPERATING INSTRUCTIONS

FRONT VIEW

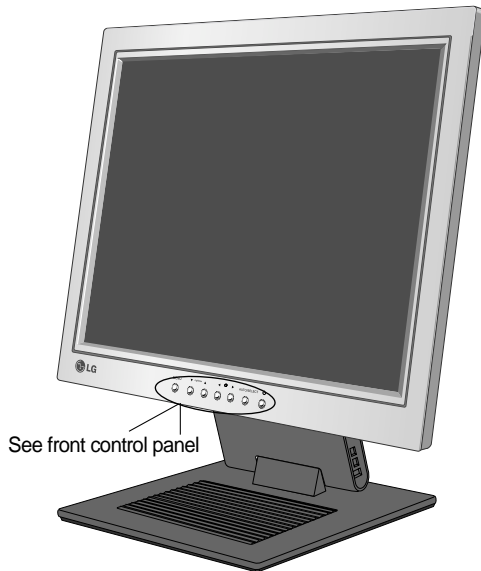

REAR VIEW

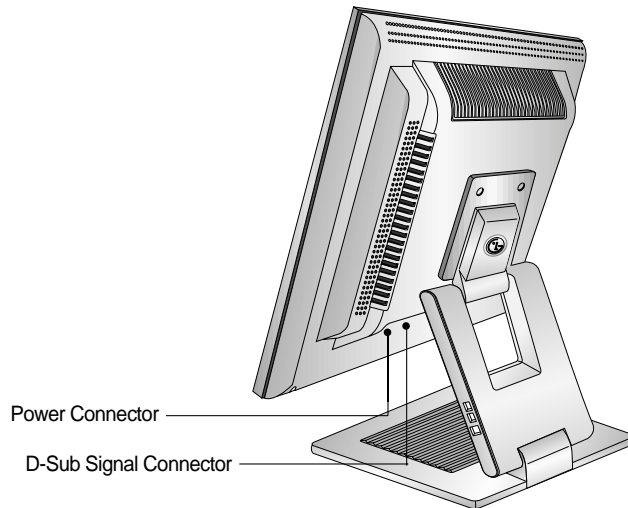

Front Control Panel

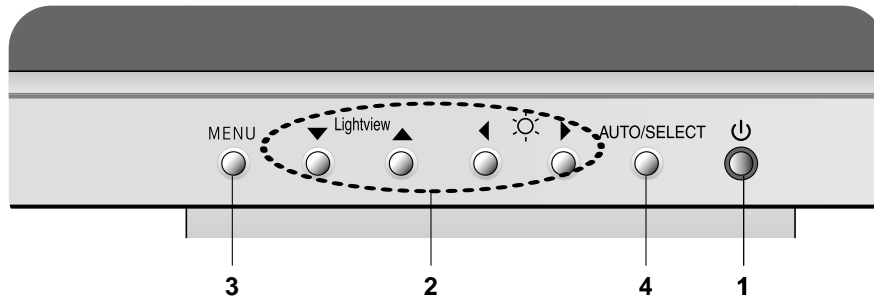

1. Power Button

Use this button to turn the display on or off.

<Power (DPMS) Indicator>

This Indicator lights up green when the display operates normally. If the display is in DPM (Energy Saving) mode, this indicator color changes to amber.

2. ▲▼/◀▶ Button

Use these buttons to choose or adjust items in the On Screen Display.

▼ LightView ▲

This function optimizes the brightness, contrast or color value to the surrounding conditions and settings and enables you to enjoy the most suitable picture by adjusting the surroundings (DAY/NIGHT/USER MODE).

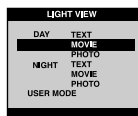

- TEXT: For viewing letters
- MOVIE: For viewing movies
- PHOTO: For viewing pictures or the photographs
- USER MODE: This function memorizes the manual adjustment -Brightness, Contrast and Color value on the On Screen Display.

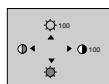

Bring up Contrast and Brightness adjustment.
: ◀☀▶ →▼▲◀▶→ MENU

3. Menu Button

Use this button to enter or exit the On Screen Display.

4. AUTO/SELECT Button

Use this button to enter a selection in the On Screen Display.



When adjusting your display settings, always press the **AUTO/SELECT** button before entering the On Screen Display(OSD). This will automatically adjust your display image to the ideal settings for the current screen resolution size (display mode).

The best display mode is **1024x768/60Hz**.

6. Control Lock(Menu button, ► button)

Press the hold the MENU button and ► button for 3 seconds: the message “CONTROLS LOCKED” appears.



You can unlock the OSD controls at any time by pushing the MENU, ► button for 3 seconds: the message “CONTROLS UNLOCKED” will appear.



Positioning your display

Adjust the position of the panel in various ways for maximum comfort.

- Tilt Range : -24°~145°

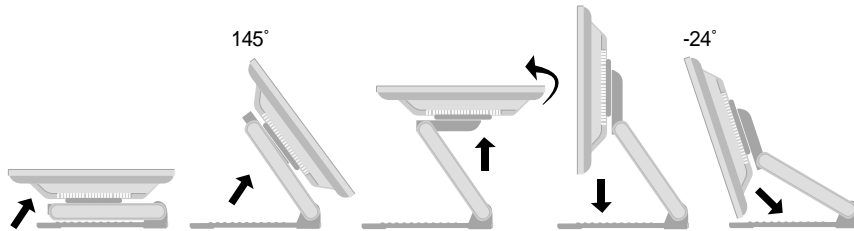

- Height Range : maximum 3.39inch (86.1mm)

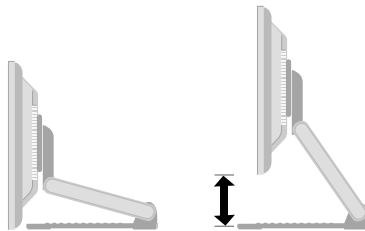

- Landscape & Portrait : You can rotate the panel 90° clockwise.
(* For detailed information, please refer to the Pivot Software CD provided.)

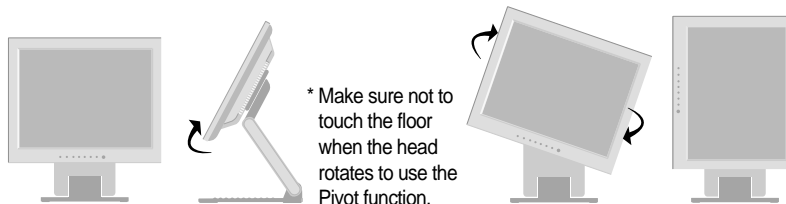

Ergonomic

It is recommended that in order to maintain an ergonomic and comfortable viewing position, the forward tilt angle of the monitor should not exceed 5 degrees.

Making use of USB (Universal Serial Bus)*

USB (Universal Serial Bus) is an innovation in connecting your different desktop peripherals conveniently to your computer. By using the USB, you will be able to connect your mouse, keyboard, and other to your monitor instead of having to connect them to your computer. This will give you greater flexibility in setting up your system. USB allows you to connect chain up to 120 devices on a single USB port, and you can “hot” plug (attach them while the computer is running) or unplug them while maintaining Plug and Play auto detection and configuration. This monitor has an integrated BUS-powered USB hub, allowing up to 2 other USB devices to be attached it.

USB connection

1. Connect the upstream port of the Display to the downstream port of the USB compliant PC or another hub using the USB cable. (Computer must have a USB port)
2. Connect the USB compliant peripherals to the downstream ports of the monitor.

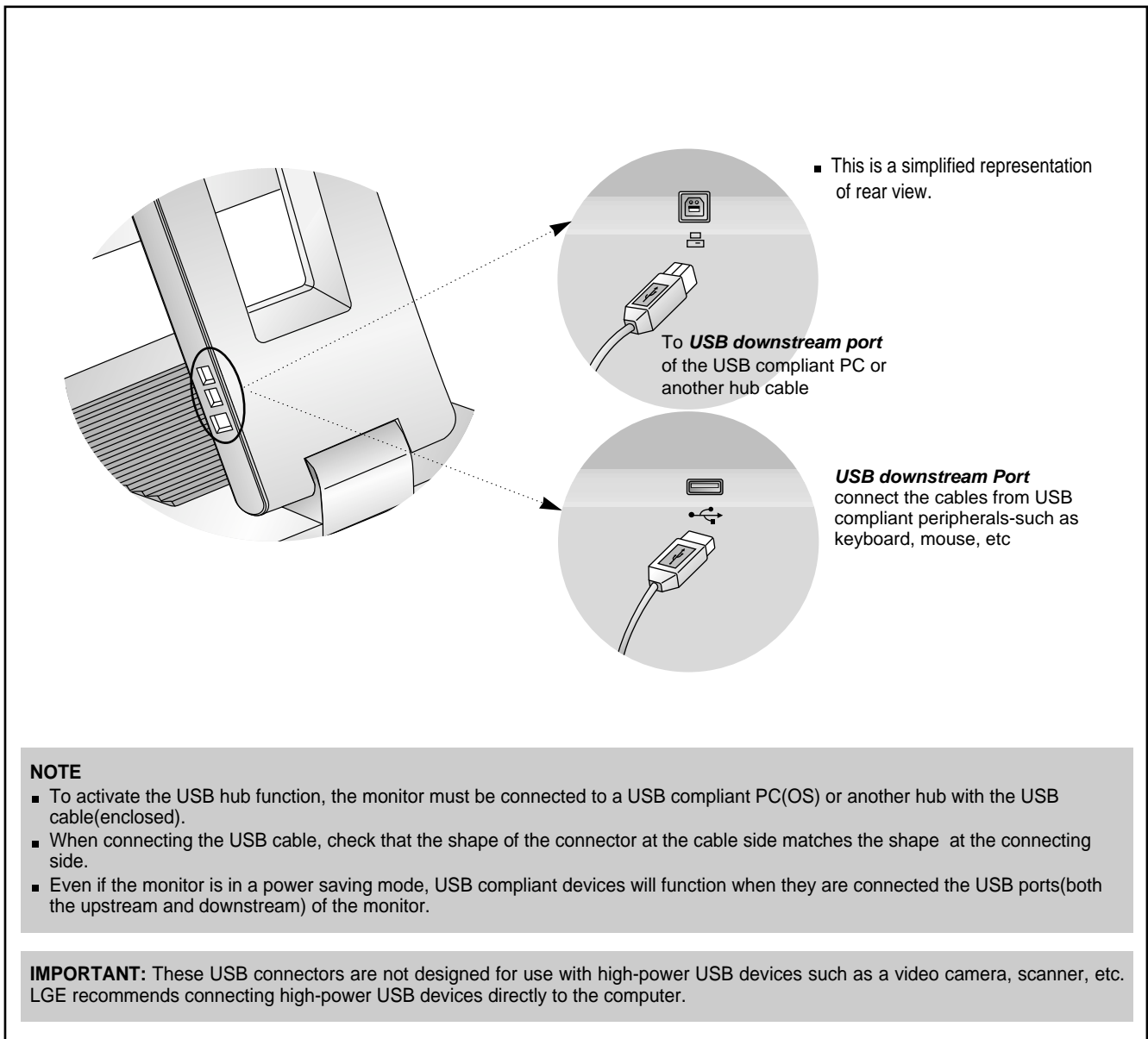

WIRING DIAGRAM

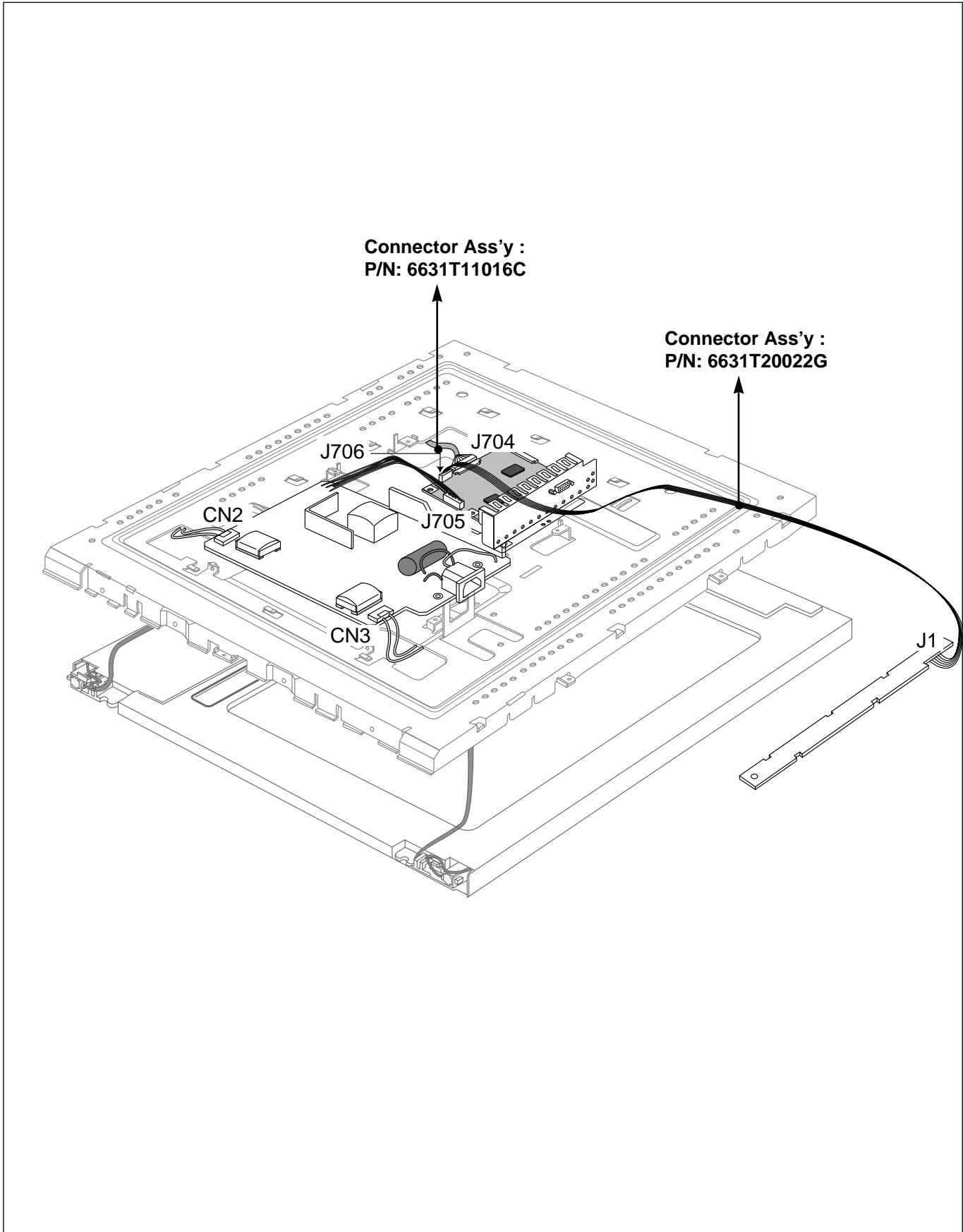

BLOCK DIAGRAM

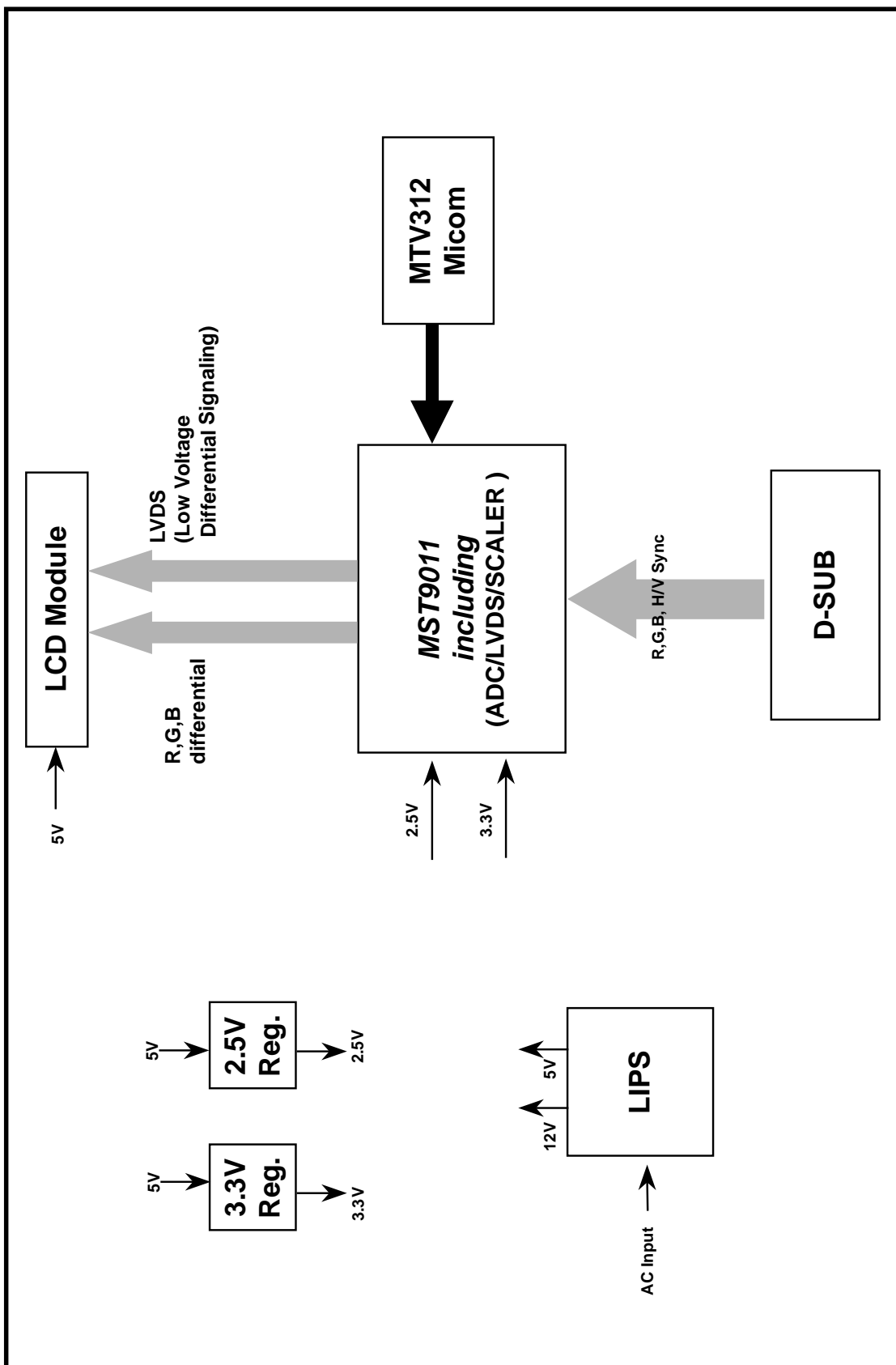

DESCRIPTION OF BLOCK DIAGRAM

1. Video Controller Part & Display Data Transmitter Part.(MST9011)

This part amplifies the level of video signal for the digital conversion and converts from the analog video signal to the digital video signal using a pixel clock.

The pixel clock for each mode is generated by the PLL.

The range of the pixel clock is from 25MHz to 80MHz.

This part consists of the Scaler.

The Scaler gets the video signal converted analog to digital, interpolates input to 1024 x 768 resolution signal and outputs 8-bit R, G, B signal to transmitter.

Especially pre-amp / ADC / Video controller/ Transmitter are merged to one chip "MST9011" by MSTAR.

This part transmit digital signal from the Scaler to the receiver of module.

2. Micom Part

This Part consists of EEPROM IC which stores control data, Reset IC and the Micom.

The Micom distinguishes polarity and frequency of the H/V Sync are supplied from signal cable.

The controlled data of each modes is stored in EEPROM.

3. Power Part

This part consists of the one 3.3V and one 2.5 regulators to convert power which is provided 5V in LIPS Board. 5V is provided for LCD Panel.

Also, 5V is converted 3.3V and 2.5V by regulator. Converted power is provided for IC in the main board.

ADJUSTMENT

All adjustment are thoroughly checked and corrected when the monitor leaves the factory, but sometimes several minor adjustment may be required.

Adjustment should be following procedure and after warming up for a minimum of 10 minutes.

Alignment appliances and tools.

- IBM Compatible PC
- Programmable Signal Generator.
(eg. VG-819 made by Astrodesign Co.)
- E(E)PROM with each mode data saved.
- Alignment Adapter and Software.

1. Adjustment for Factory Preset Mode

- 1) Run alignment program for L1510BL on the IBM compatible PC.
- 2) Select EEPROM All Init. command and Enter.
- 3) Display cross hatch pattern at Mode 1.
- 4) Select EDID WRITE command and Enter.

2. Adjustment for White Balance

- 1) Display color 0,0 pattern at Mode 13.
- 2) Set External Bright to MAX position and Contrast to MAX Position.
- 3) Select PRESET START → BIAS CAL command and Enter.
- 4) No attempt to manually adjust, BIAS data is automatically adjusted and saved to the EEPROM.
- 5) Display color 15,0 pattern at Mode 13.
- 6) Select DRIVE CAL command and Enter.
- 7) Color 1 (9300K) and Color 2 (6500K) are automatically adjusted and saved to the EEPROM.
- 8) Select PRESET EXIT command and Enter.

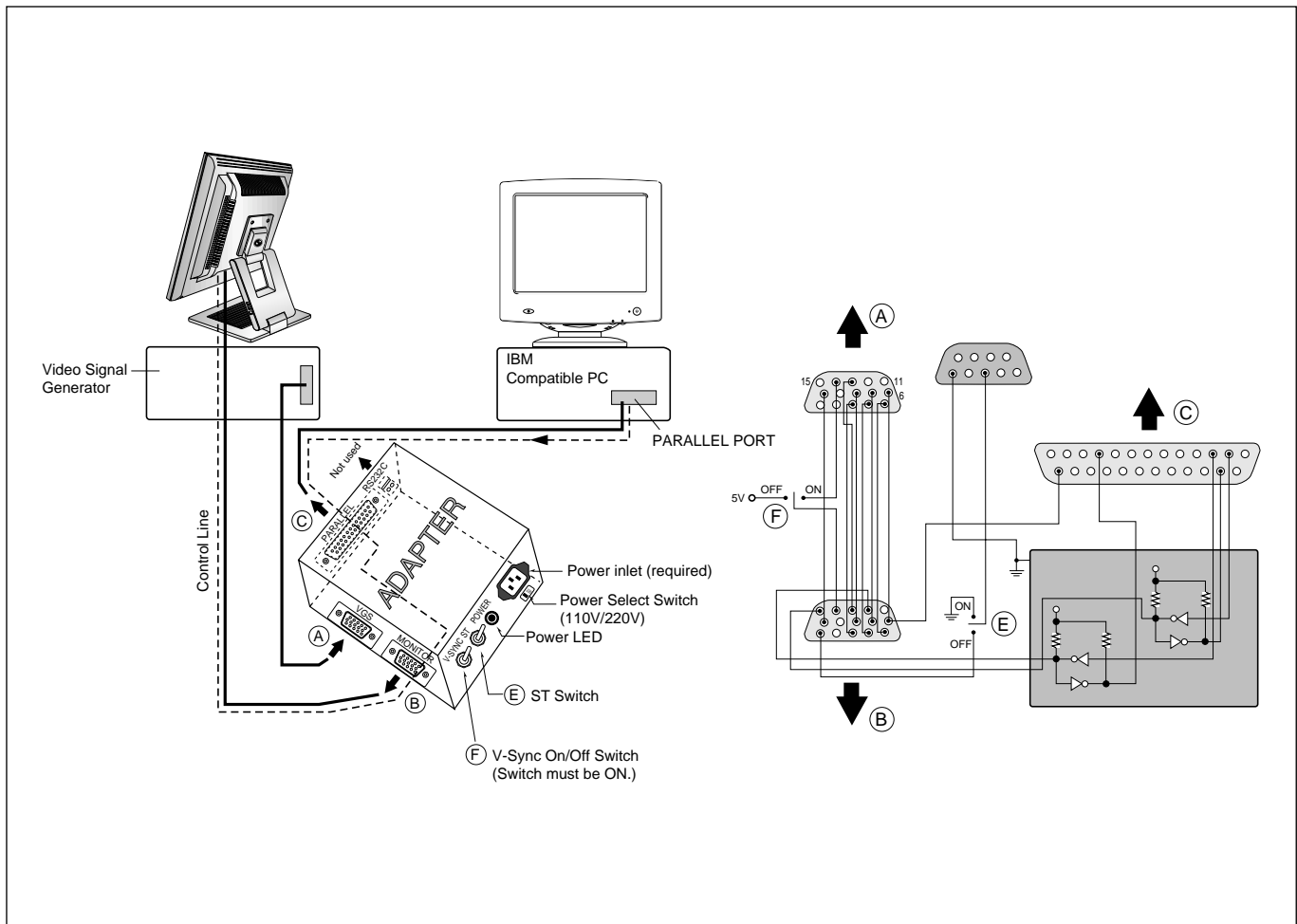
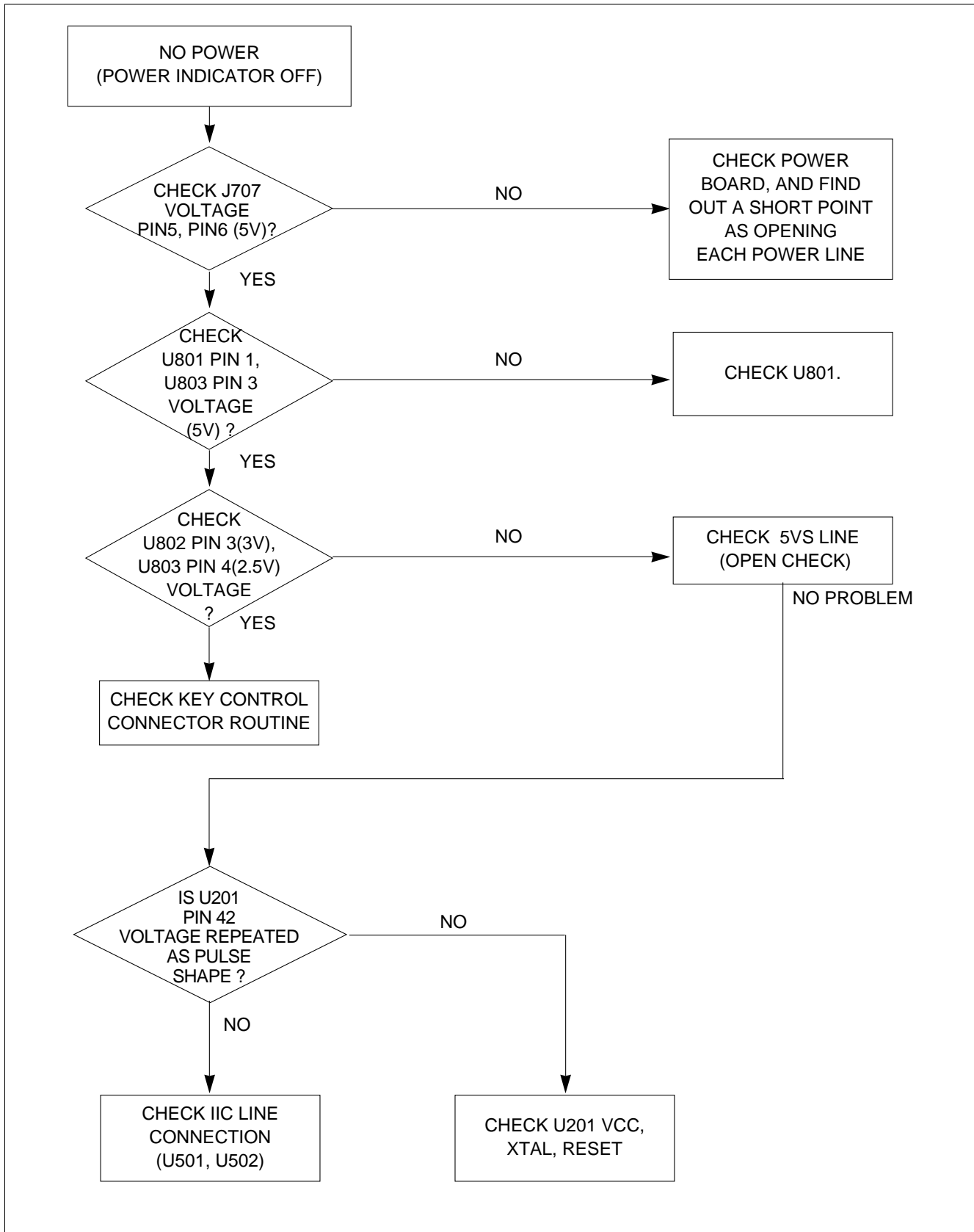

Figure 1. Cable Connection

TROUBLESHOOTING GUIDE

1. NO POWER



2. NO RASTER (OSD IS NOT DISPLAYED) – LIPS

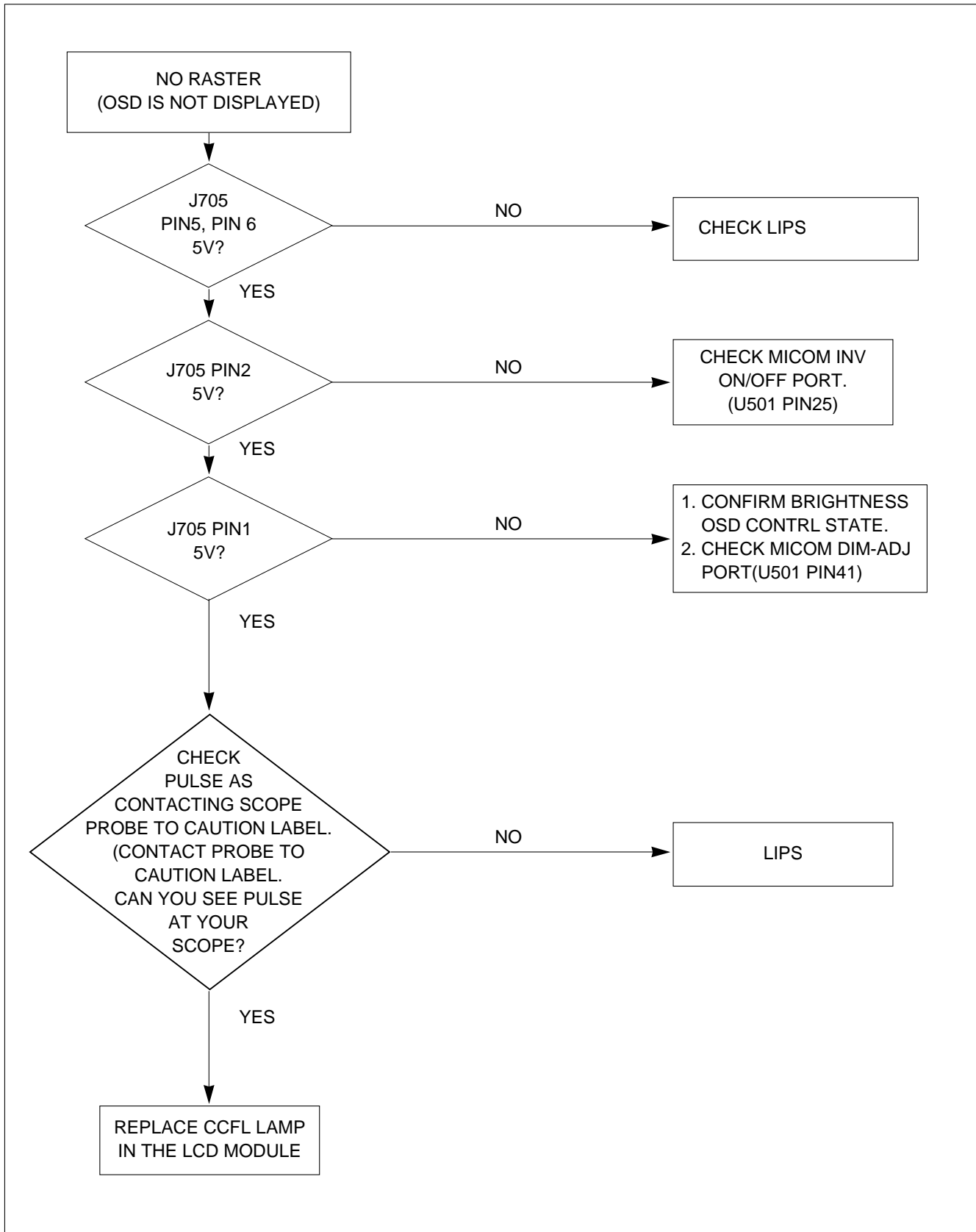

3. NO RASTER (OSD IS NOT DISPLAYED) – MST9011

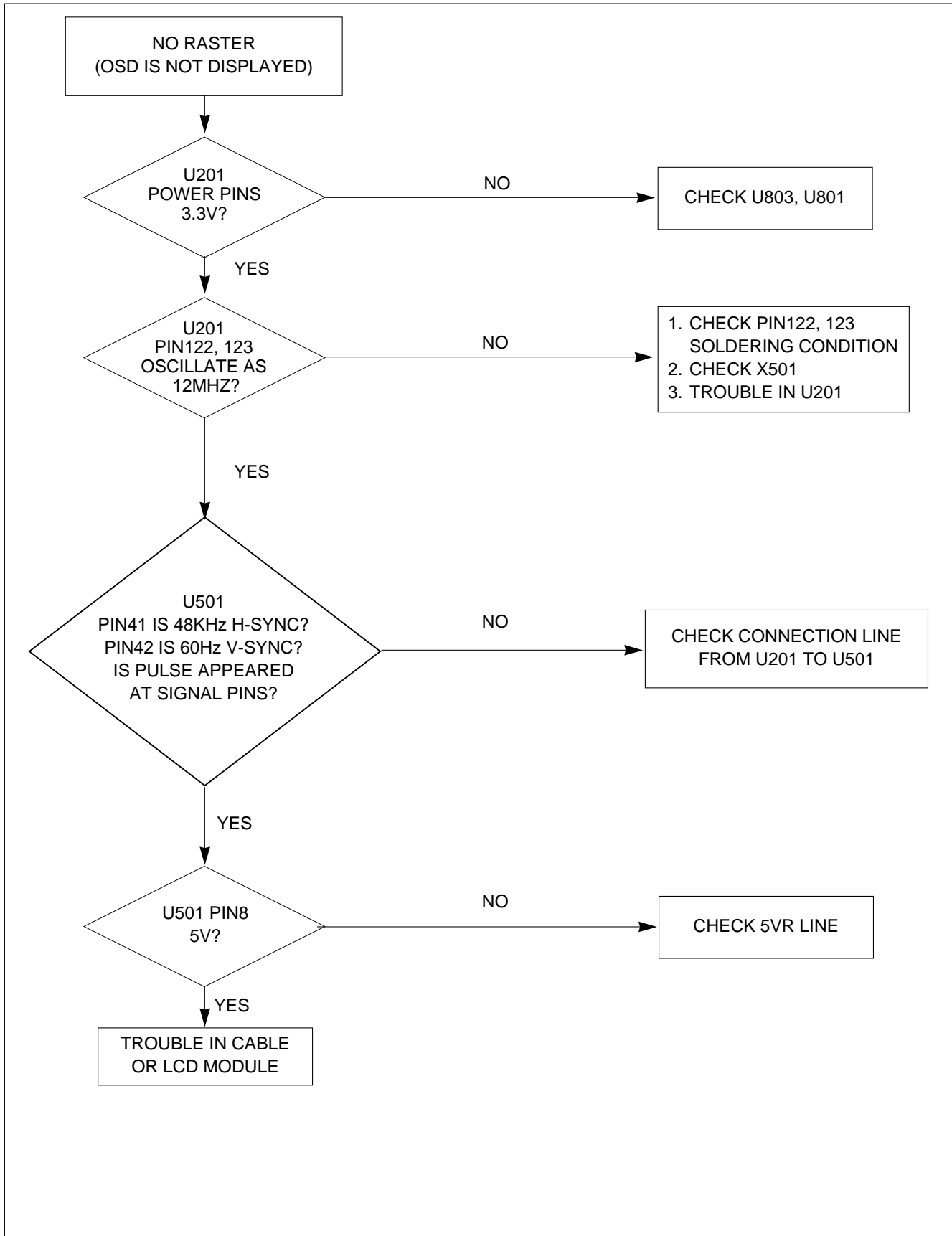

4. NO RASTER (OSD IS DISPLAYED) – MST9011

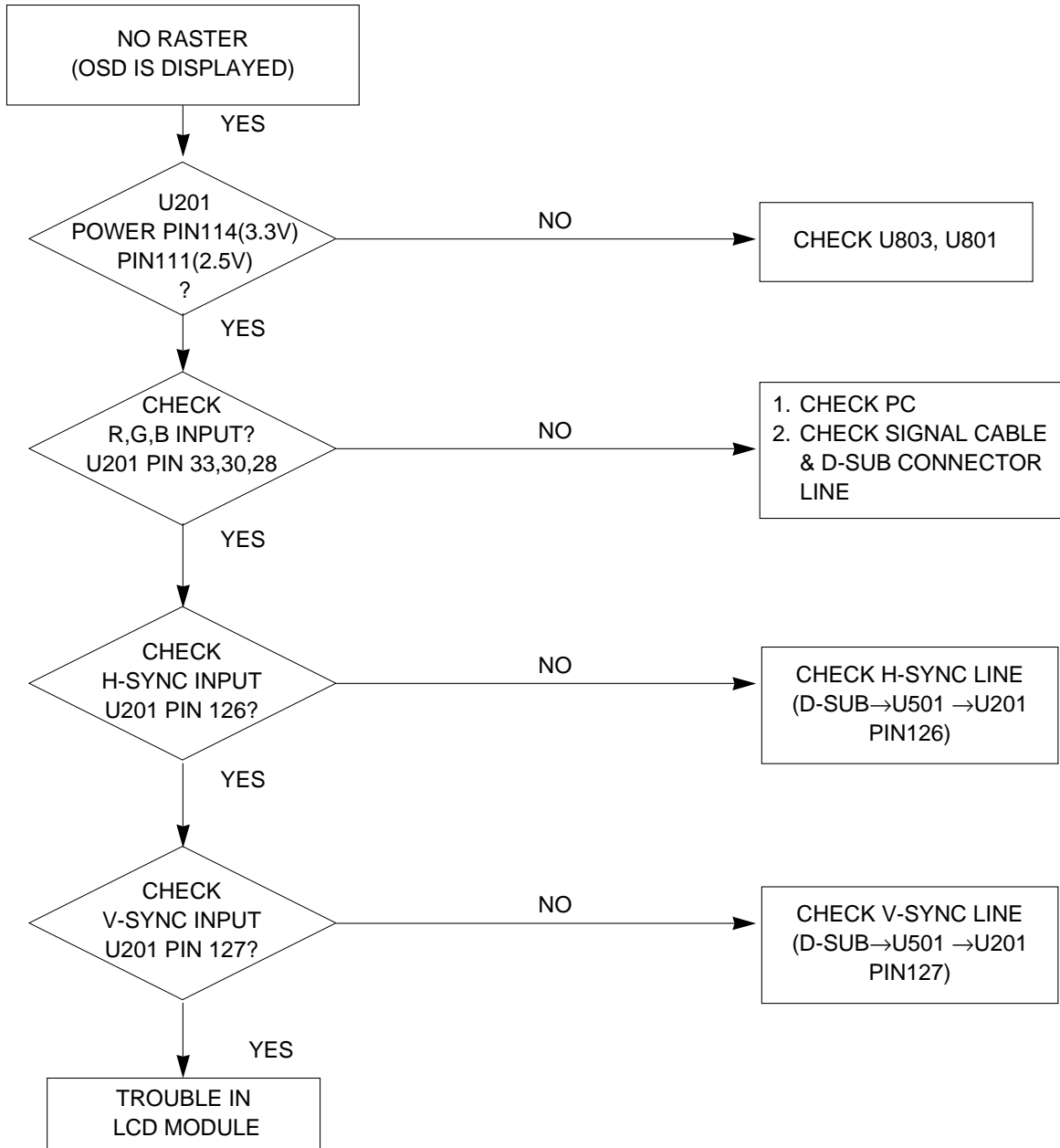

PRINTED CIRCUIT BOARD

1. MAIN BOARD (Component Side)

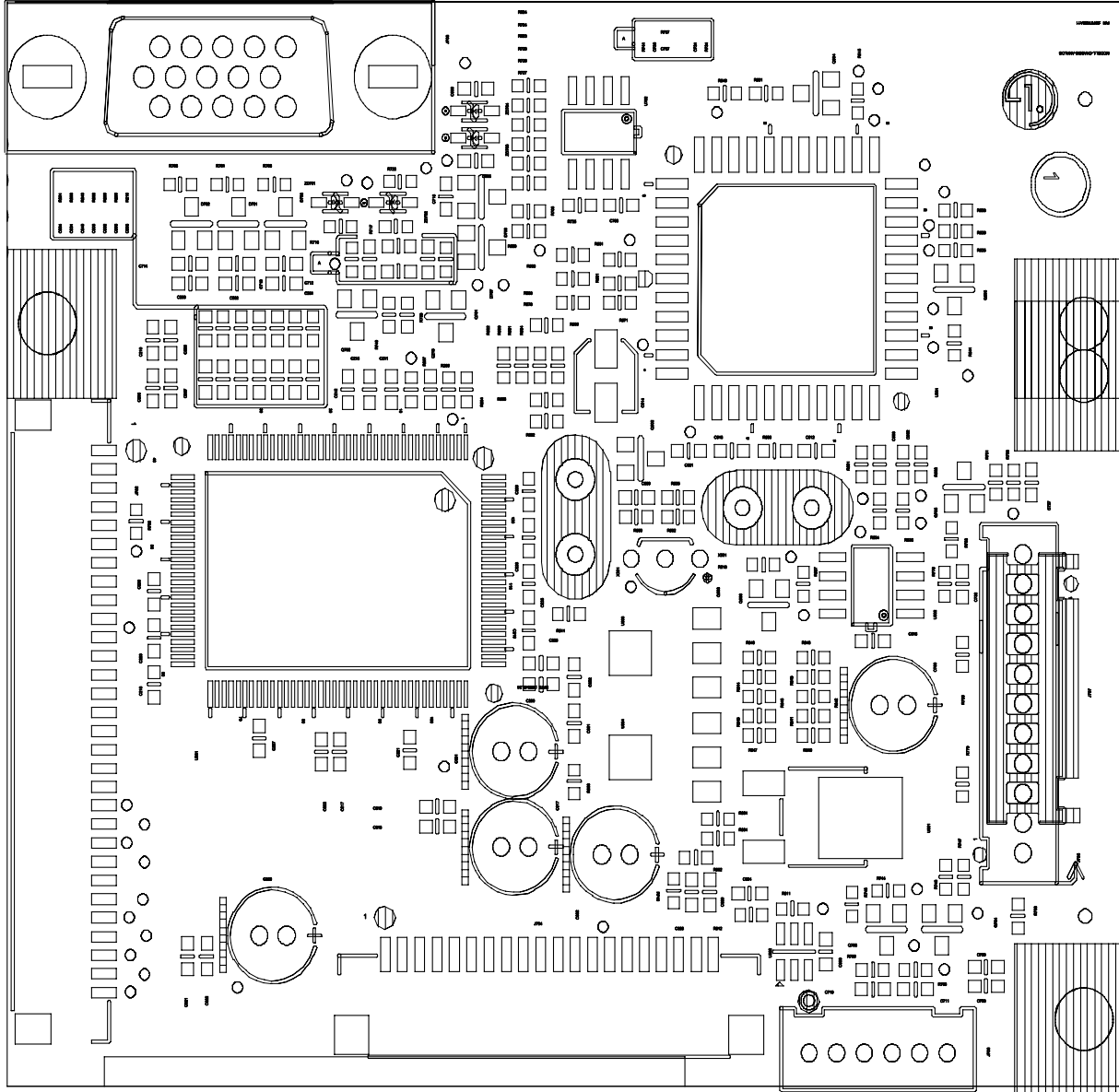

2. MAIN ()

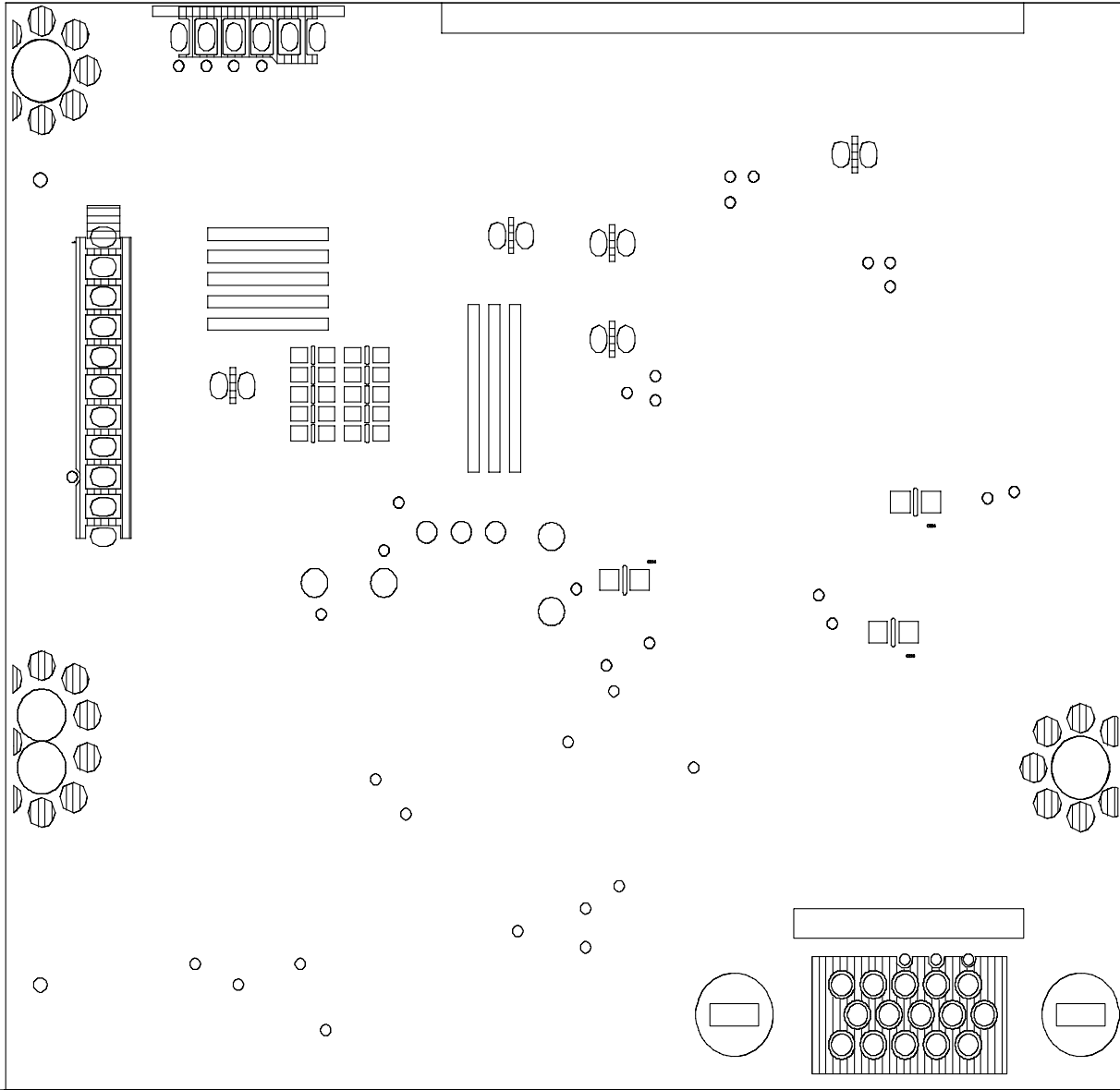

3.CONTROL ()

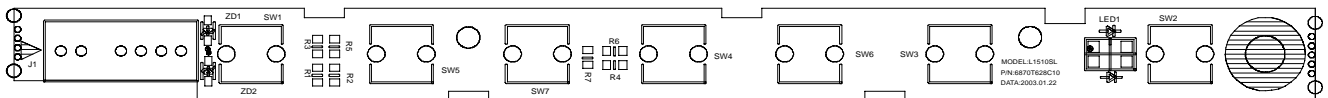

4.POWER ()

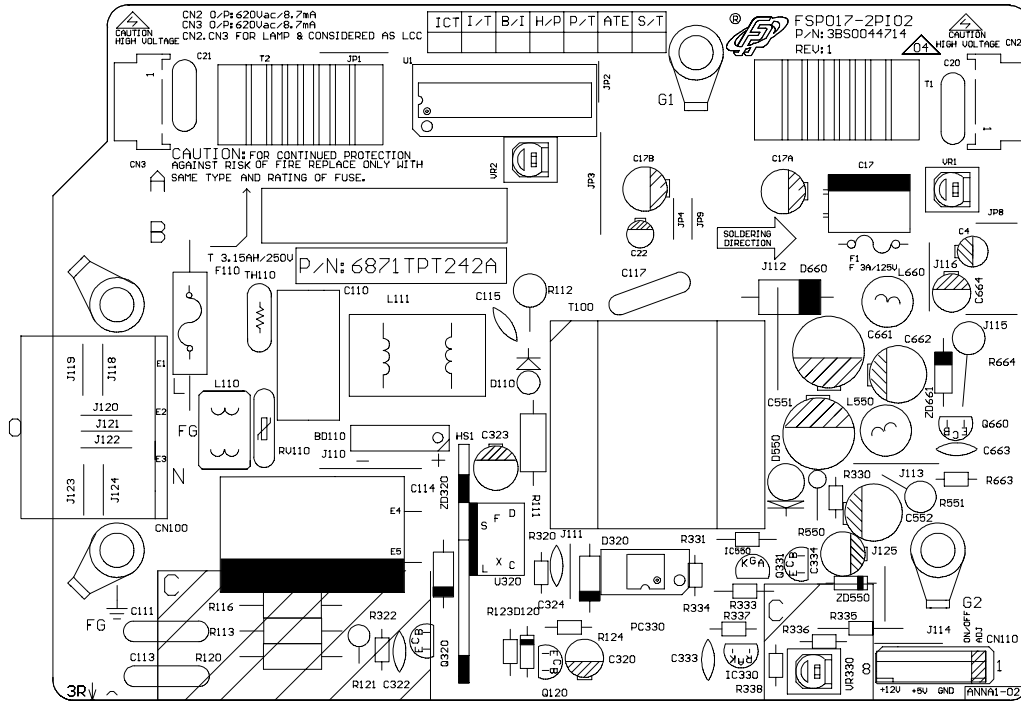

5.POWER ()

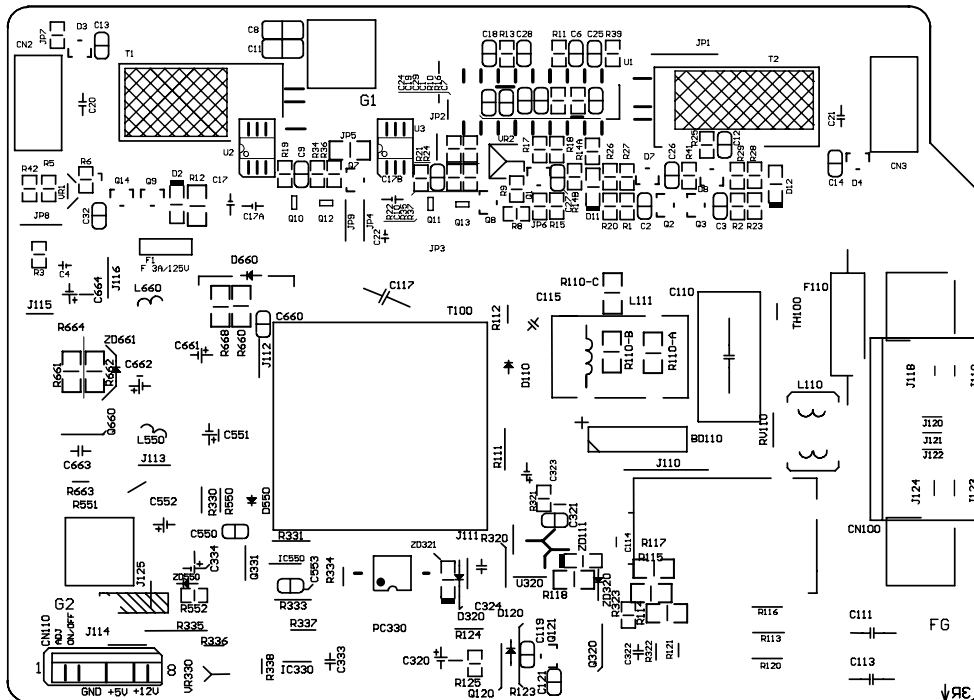

EXPLODED VIEW

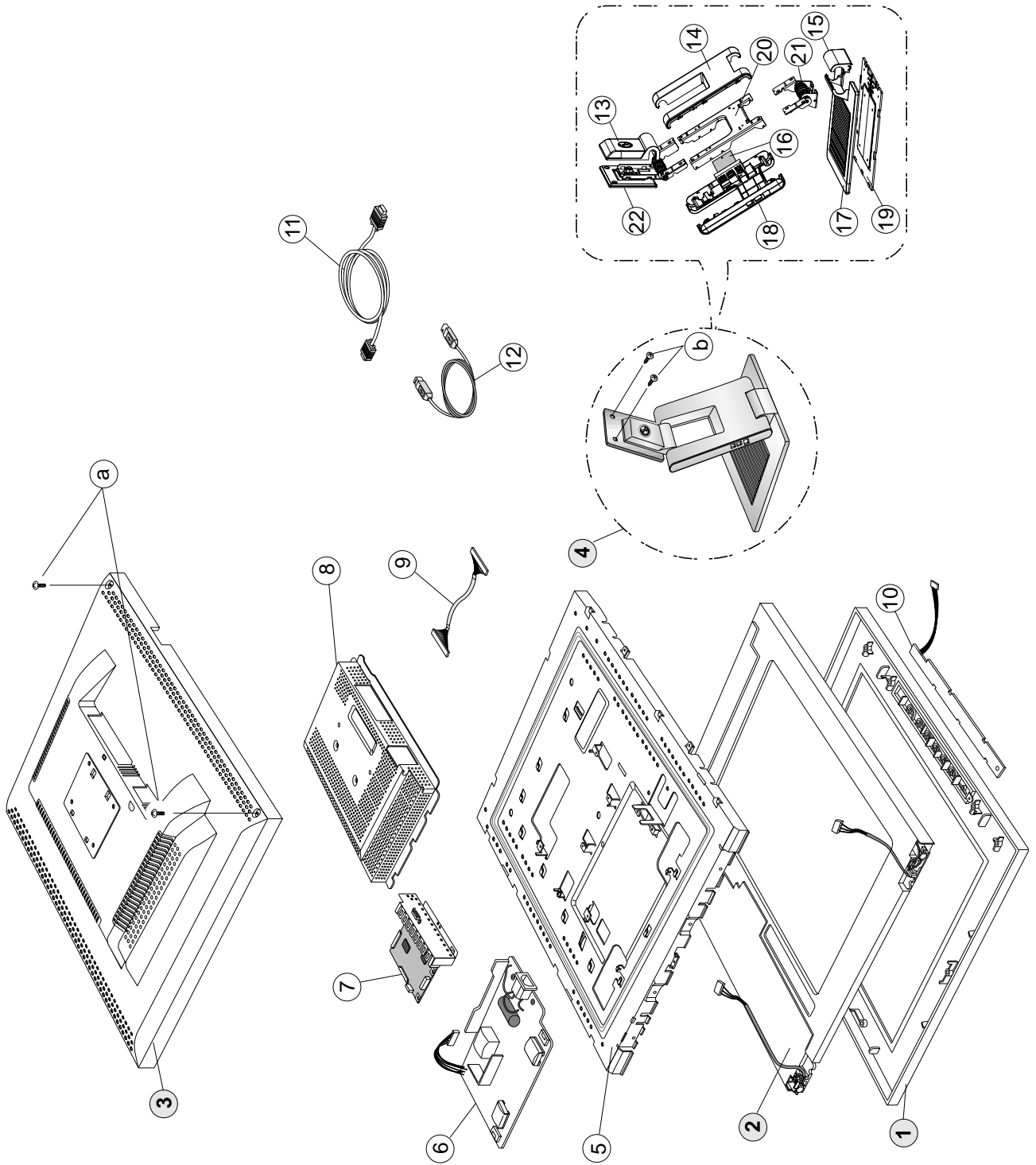

EXPLODED VIEW PARTS LIST

Ref. No.	Part No.	Description
1	3091TKL067H	CABINET ASSEMBLY, L1510BL BRAND L038 .
2	6304FLP025A	LCD(LIQUID CRYSTAL DISPLAY), LM150X06-A3M1 LG PHILIPS TFT COLOR 15.0 INCH XGA LVDS SMM
	or 6304FLP068A	LCD(LIQUID CRYSTAL DISPLAY), LM150X06-A4C3 LG PHILIPS TFT COLOR LPL
3	3809TKL026Y	BACK COVER ASSEMBLY, L1510SL 3808TKL029 .
4	3043TKK095A	TILT SWIVEL ASSEMBLY, LB504J . PIVOT&2-HINGE
5	4951TKS091R	METAL ASSEMBLY, FRAME MAIN (L1510SL,LPL P4)
6	6871TPT242B	PWB(PCB) ASSEMBLY,POWER, 15" LPL(L1510SL) POWER TOTAL SPI FSP017-2PI02
	or 6871TPT234D	PWB(PCB) ASSEMBLY,POWER, L1510SL POWER TOTAL POWERNET PWI1510LG 12V/1.2A 5V/1A LIPS FOR L-CHASSIS LPL
	or 6871TPT236B	PWB(PCB) ASSEMBLY,POWER, ADP-30EP POWER TOTAL DELTA L1510SL LIPS
7	3313TL5061A	MAIN TOTAL ASSEMBLY, L1510SL BRAND CL-32
8	4950TKK424F	METAL, SHIELD REAR(LB504N)
9	6631T11016C	CONNECTOR ASSEMBLY, 20P H-H 100MM UL20276 I/FACE CABLE LB500K
10	6871TST383A	PWB(PCB) ASSEMBLY,SUB, L1510SL CONTROL TOTAL BRAND CL-32
11	6850TD9004D	CABLE,D-SUB, UL20276-9C(5.8MM) DT 1560MM GRAY(85964) LB500L DM
	or 6850TD9004A	CABLE,D-SUB, UL20276-9C(5.8MM) DT 1870MM GRAY(85964) LB500K DM
12	6866TDU002D	CABLE,D-SUB, UL20276SB10P+2C AWG#30 DT 1870MM GRAY(85964) BRAND DM
13	3550TKK264A	COVER, LB504J HINGE ROTATE
14	3550TKK266A	COVER, LB504J STAND REAR .
15	3550TKK268A	COVER, LB504J HINGE BASE
16	6871TUT015A	PWB(PCB) ASSEMBLY,USB, LB886F SUB TOTAL BRAND CL-29
17	3550TKK267A	COVER, LB504J BASE TOP .
18	3550TKK265A	COVER, LB504J STAND FRONT WITH USB
19	4950TKK444A	METAL, BASE LB504J
20	4950TKK443A	METAL, STAND LB504J
21	4951TKK089A	METAL ASSEMBLY, TILT UNIT BASE HINGE
22	4951TKK088A	METAL ASSEMBLY, TILT UNIT PORTRAIT&UPPER HINGE
a	332-068U	SCREW, PPB+3*8 (MSWR/FZMW1)
b	332-105G	SCREW,DRAWING, PVS+4*10(MSWR/BK)

REPLACEMENT PARTS LIST

CAUTION: BEFORE REPLACING ANY OF THESE COMPONENTS, READ CAREFULLY THE **SAFETY PRECAUTIONS** IN THIS MANUAL.

* NOTE : **S** SAFETY Mark **AL** ALTERNATIVE PARTS

DATE: 2003. 5. 9.				
*S	*AL	LOC. NO.	PART NO.	DESCRIPTION / SPECIFICATION
MAIN BOARD				
CAPACITORS				
		C201	0CC180CK41A	18PF 1608 50V 5% R/TP NP0
		C202	0CC180CK41A	18PF 1608 50V 5% R/TP NP0
		C203	0CC180CK41A	18PF 1608 50V 5% R/TP NP0
		C204	0CK104CK56A	0.1UF 1608 50V 10% R/TP X7R
		C205	0CK104CK56A	0.1UF 1608 50V 10% R/TP X7R
		C206	0CK104CK56A	0.1UF 1608 50V 10% R/TP X7R
		C207	0CK104CK56A	0.1UF 1608 50V 10% R/TP X7R
		C208	0CK104CK56A	0.1UF 1608 50V 10% R/TP X7R
		C209	0CK104CK56A	0.1UF 1608 50V 10% R/TP X7R
		C210	0CK104CK56A	0.1UF 1608 50V 10% R/TP X7R
		C211	0CK104CK56A	0.1UF 1608 50V 10% R/TP X7R
		C212	0CK104CK56A	0.1UF 1608 50V 10% R/TP X7R
		C215	0CK104CK56A	0.1UF 1608 50V 10% R/TP X7R
		C216	0CK104CK56A	0.1UF 1608 50V 10% R/TP X7R
		C217	0CK104CK56A	0.1UF 1608 50V 10% R/TP X7R
		C218	0CK104CK56A	0.1UF 1608 50V 10% R/TP X7R
		C219	0CK104CK56A	0.1UF 1608 50V 10% R/TP X7R
		C220	0CK104CK56A	0.1UF 1608 50V 10% R/TP X7R
		C221	0CK104CK56A	0.1UF 1608 50V 10% R/TP X7R
		C222	0CK104CK56A	0.1UF 1608 50V 10% R/TP X7R
		C223	0CK104CK56A	0.1UF 1608 50V 10% R/TP X7R
		C225	0CK104CK56A	0.1UF 1608 50V 10% R/TP X7R
		C226	0CK104CK56A	0.1UF 1608 50V 10% R/TP X7R
		C227	0CK104CK56A	0.1UF 1608 50V 10% R/TP X7R
		C230	0CK104CK56A	0.1UF 1608 50V 10% R/TP X7R
		C231	0CK104CK56A	0.1UF 1608 50V 10% R/TP X7R
		C232	0CK104CK56A	0.1UF 1608 50V 10% R/TP X7R
		C233	0CK104CK56A	0.1UF 1608 50V 10% R/TP X7R
		C240	0CK104CK56A	0.1UF 1608 50V 10% R/TP X7R
		C501	0CK104CK56A	0.1UF 1608 50V 10% R/TP X7R
		C502	0CC101CK41A	100PF 1608 50V 5% R/TP NP0
		C503	0CC101CK41A	100PF 1608 50V 5% R/TP NP0
		C505	0CC101CK41A	100PF 1608 50V 5% R/TP NP0
		C506	0CC101CK41A	100PF 1608 50V 5% R/TP NP0
		C512	0CC180CK41A	18PF 1608 50V 5% R/TP NP0
		C513	0CC030CK01A	3PF 1608 50V 0.25 PF R/TP NP
		C514	0CH8106F611	10UF 16V M 85STD(CYL) R/TP
		C516	0CK104CK56A	0.1UF 1608 50V 10% R/TP X7R
		C550	0CC102CK41A	1000PF 1608 50V 5% R/TP NP0
		C703	0CK104CK56A	0.1UF 1608 50V 10% R/TP X7R
		C707	0CC680CK41A	68PF 1608 50V 5% R/TP NP0
		C708	0CK103CK51A	0.01UF 1608 50V 10% R/TP B(Y)
		C709	0CK103CK51A	0.01UF 1608 50V 10% R/TP B(Y)
		C710	0CK103CK51A	0.01UF 1608 50V 10% R/TP B(Y)
		C711	0CK103CK51A	0.01UF 1608 50V 10% R/TP B(Y)
		C712	0CK104CK56A	0.1UF 1608 50V 10% R/TP X7R
		C713	0CK104CK56A	0.1UF 1608 50V 10% R/TP X7R
		C714	0CK104CK56A	0.1UF 1608 50V 10% R/TP X7R
		C715	0CK104CK56A	0.1UF 1608 50V 10% R/TP X7R
		C727	0CK105CD56A	1UF 1608 10V 10% R/TP X7R
		C730	0CC101CK41A	100PF 1608 50V 5% R/TP NP0
		C731	0CC680CK41A	68PF 1608 50V 5% R/TP NP0

DATE: 2003. 5. 9.				
*S	*AL	LOC. NO.	PART NO.	DESCRIPTION / SPECIFICATION
		C732	0CK103CK51A	0.01UF 1608 50V 10% R/TP B(Y)
		C760	0CE107EF610	"100UF KMG,RD 16V 20% FL BULK"
		C801	0CK103CK51A	0.01UF 1608 50V 10% R/TP B(Y)
		C802	0CK104CK56A	0.1UF 1608 50V 10% R/TP X7R
		C803	0CK105CD56A	1UF 1608 10V 10% R/TP X7R
		C804	0CC102CK41A	1000PF 1608 50V 5% R/TP NP0
		C817	0CE107EF610	"100UF KMG,RD 16V 20% FL BULK"
		C818	0CK104CK56A	0.1UF 1608 50V 10% R/TP X7R
		C819	0CK103CK51A	0.01UF 1608 50V 10% R/TP B(Y)
		C820	0CE107EF610	"100UF KMG,RD 16V 20% FL BULK"
		C821	0CK103CK51A	0.01UF 1608 50V 10% R/TP B(Y)
		C822	0CK104CK56A	0.1UF 1608 50V 10% R/TP X7R
		C828	0CK104CK56A	0.1UF 1608 50V 10% R/TP X7R
		C829	0CK103CK51A	0.01UF 1608 50V 10% R/TP B(Y)
		C831	0CE107EF610	"100UF KMG,RD 16V 20% FL BULK"
		C832	0CE107EF610	"100UF KMG,RD 16V 20% FL BULK"
DIODEs				
		D701	0DS226009AA	KDS226 TP KEC SOT-23 80V 30
		D702	0DS226009AA	KDS226 TP KEC SOT-23 80V 30
		D703	0DS226009AA	KDS226 TP KEC SOT-23 80V 30
		D706	0DS226009AA	KDS226 TP KEC SOT-23 80V 30
		D707	0DD184009AA	KDS184 TP KEC - 85V - - - 30
		ZD701	0DZ560009GB	BZT52C5V6S DIODES R/TP SOD32
		ZD702	0DZ560009GB	BZT52C5V6S DIODES R/TP SOD32
		ZD703	0DZ560009GB	BZT52C5V6S DIODES R/TP SOD32
		ZD704	0DZ560009GB	BZT52C5V6S DIODES R/TP SOD32
ICs				
		U201	0IPRPM3003A	MST9011 ANALOG MSTAR 128P LQ
		U501	0IZZTSZ250B	MYSON 44P PLCC ST OTP L1510S
		U502	0ISG240860B	M24C08W6 SGS-THOMSON 8SOP R/
		U702	0ICS240213A	CAT24WC02J-TE13 8P SOP TP 2K
		U801	0IPMGKE011A	KIA78D33F KEC DPAK R/TP 3.3V
		U802	0TFV180023A	VISHAY SI3865DV R/TP TSOP-6
		U803	0IPMGNS001D	LM1117MPX-2.5 NATIONAL SEMIC
TRANSISTOR				
		Q502	0TR390409AE	FAIRCHILD KST3904(LGEMTF) TP
		Q503	0IKE704200H	KIA7042AP TO-92 TP 4.2 VOLT
		Q504	0TR390409AE	FAIRCHILD KST3904(LGEMTF) TP
		Q505	0TR390409AE	FAIRCHILD KST3904(LGEMTF) TP
		Q506	0TR390409AE	FAIRCHILD KST3904(LGEMTF) TP
		Q701	0TR390409AE	FAIRCHILD KST3904(LGEMTF) TP
		Q702	0TR390409AE	FAIRCHILD KST3904(LGEMTF) TP
		Q703	0TR390609FA	KST3906-MTF TP SAMSUNG SOT2
		Q704	0TR390609FA	KST3906-MTF TP SAMSUNG SOT2
		Q705	0TR390409AE	FAIRCHILD KST3904(LGEMTF) TP

DATE: 2003. 5. 9.				
*S	*AL	LOC. NO.	PART NO.	DESCRIPTION / SPECIFICATION
RESISTORS				
		R201	0RJ1500D677	150 OHM 1/10 W 5% 1608 R/TP
		R202	0RJ1500D677	150 OHM 1/10 W 5% 1608 R/TP
		R203	0RJ1500D677	150 OHM 1/10 W 5% 1608 R/TP
		R204	0RJ1002D677	10K OHM 1/10 W 5% 1608 R/TP
		R205	0RJ1002D677	10K OHM 1/10 W 5% 1608 R/TP
		R207	0RJ4700D677	470 OHM 1/10 W 5% 1608 R/TP
		R208	0RJ1500D677	150 OHM 1/10 W 5% 1608 R/TP
		R209	0RJ1500D677	150 OHM 1/10 W 5% 1608 R/TP
		R210	0RJ1500D677	150 OHM 1/10 W 5% 1608 R/TP
		R240	0RJ1500D677	150 OHM 1/10 W 5% 1608 R/TP
		R501	0RJ4701D677	4.7K OHM 1/10 W 5% 1608 R/TP
		R502	0RJ4701D677	4.7K OHM 1/10 W 5% 1608 R/TP
		R504	0RJ4701D677	4.7K OHM 1/10 W 5% 1608 R/TP
		R509	0RJ4701D677	4.7K OHM 1/10 W 5% 1608 R/TP
		R510	0RJ4700D677	470 OHM 1/10 W 5% 1608 R/TP
		R511	0RJ4700D677	470 OHM 1/10 W 5% 1608 R/TP
		R515	0RJ1002D677	10K OHM 1/10 W 5% 1608 R/TP
		R520	0RJ4701D677	4.7K OHM 1/10 W 5% 1608 R/TP
		R522	0RJ1000D677	100 OHM 1/10 W 5% 1608 R/TP
		R523	0RJ0332D677	33 OHM 1/10 W 5% 1608 R/TP
		R524	0RJ0332D677	33 OHM 1/10 W 5% 1608 R/TP
		R525	0RJ1002D677	10K OHM 1/10 W 5% 1608 R/TP
		R528	0RJ1000D677	100 OHM 1/10 W 5% 1608 R/TP
		R529	0RJ1000D677	100 OHM 1/10 W 5% 1608 R/TP
		R530	0RJ1000D677	100 OHM 1/10 W 5% 1608 R/TP
		R531	0RJ1000D677	100 OHM 1/10 W 5% 1608 R/TP
		R532	0RJ3301D677	3.3K OHM 1/10 W 5% 1608 R/TP
		R533	0RJ0332D677	33 OHM 1/10 W 5% 1608 R/TP
		R534	0RJ0332D677	33 OHM 1/10 W 5% 1608 R/TP
		R535	0RJ3301D677	3.3K OHM 1/10 W 5% 1608 R/TP
		R537	0RJ4701D677	4.7K OHM 1/10 W 5% 1608 R/TP
		R540	0RJ1002D677	10K OHM 1/10 W 5% 1608 R/TP
		R541	0RJ4701D677	4.7K OHM 1/10 W 5% 1608 R/TP
		R551	0RJ4702D677	47000 OHM 1/10 W 5% 1608 R/T
		R571	0RJ1000D677	100 OHM 1/10 W 5% 1608 R/TP
		R581	0RJ1000D677	100 OHM 1/10 W 5% 1608 R/TP
		R590	0RJ1000D677	100 OHM 1/10 W 5% 1608 R/TP
		R591	0RJ1000D677	100 OHM 1/10 W 5% 1608 R/TP
		R592	0RJ1000D677	100 OHM 1/10 W 5% 1608 R/TP
		R593	0RJ1000D677	100 OHM 1/10 W 5% 1608 R/TP
		R701	0RJ0752D677	75 OHM 1/10 W 5% 1608 R/TP
		R703	0RJ0752D677	75 OHM 1/10 W 5% 1608 R/TP
		R705	0RJ1000D677	100 OHM 1/10 W 5% 1608 R/TP
		R706	0RJ0752D677	75 OHM 1/10 W 5% 1608 R/TP
		R707	0RJ0682D677	68 OHM 1/10 W 5% 1608 R/TP
		R708	0RJ4700D677	470 OHM 1/10 W 5% 1608 R/TP
		R709	0RJ4700D677	470 OHM 1/10 W 5% 1608 R/TP
		R716	0RJ4701D677	4.7K OHM 1/10 W 5% 1608 R/TP
		R717	0RJ4701D677	4.7K OHM 1/10 W 5% 1608 R/TP
		R722	0RJ1000D677	100 OHM 1/10 W 5% 1608 R/TP
		R723	0RJ0332D677	33 OHM 1/10 W 5% 1608 R/TP
		R724	0RJ0332D677	33 OHM 1/10 W 5% 1608 R/TP
		R725	0RJ4701D677	4.7K OHM 1/10 W 5% 1608 R/TP
		R726	0RJ1002D677	10K OHM 1/10 W 5% 1608 R/TP
		R727	0RJ1002D677	10K OHM 1/10 W 5% 1608 R/TP
		R733	0RJ1001D677	1K OHM 1/10 W 5% 1608 R/TP
		R734	0RJ4701D677	4.7K OHM 1/10 W 5% 1608 R/TP
		R735	0RJ0000D677	0 OHM 1/10 W 5% 1608 R/TP
		R740	0RJ1001D677	1K OHM 1/10 W 5% 1608 R/TP
		R741	0RJ4701D677	4.7K OHM 1/10 W 5% 1608 R/TP
		R744	0RJ4701D677	4.7K OHM 1/10 W 5% 1608 R/TP

DATE: 2003. 5. 9.				
*S	*AL	LOC. NO.	PART NO.	DESCRIPTION / SPECIFICATION
		R745	0RJ4701D677	4.7K OHM 1/10 W 5% 1608 R/TP
		R747	0RJ4701D677	4.7K OHM 1/10 W 5% 1608 R/TP
		R748	0RJ4701D677	4.7K OHM 1/10 W 5% 1608 R/TP
		R749	0RJ0000D677	0 OHM 1/10 W 5% 1608 R/TP
		R750	0RJ1001D677	1K OHM 1/10 W 5% 1608 R/TP
		R751	0RJ1001D677	1K OHM 1/10 W 5% 1608 R/TP
		R753	0RJ1001D677	1K OHM 1/10 W 5% 1608 R/TP
		R779	0RJ1002D677	10K OHM 1/10 W 5% 1608 R/TP
		R802	0RJ0000D677	0 OHM 1/10 W 5% 1608 R/TP
		R803	0RJ0000D677	0 OHM 1/10 W 5% 1608 R/TP
		R811	0RJ2202D677	22K OHM 1/10 W 5% 1608 R/TP
		R812	0RJ5600D677	560 OHM 1/10 W 5% 1608 R/TP
		R840	0RJ0471D677	4.7 OHM 1/10 W 5% 1608 R/TP
		R841	0RJ0471D677	4.7 OHM 1/10 W 5% 1608 R/TP
		R842	0RJ0471D677	4.7 OHM 1/10 W 5% 1608 R/TP
		R843	0RJ0471D677	4.7 OHM 1/10 W 5% 1608 R/TP
		R844	0RJ0471D677	4.7 OHM 1/10 W 5% 1608 R/TP
		R845	0RJ0471D677	4.7 OHM 1/10 W 5% 1608 R/TP
		R846	0RJ0471D677	4.7 OHM 1/10 W 5% 1608 R/TP
		R847	0RJ0471D677	4.7 OHM 1/10 W 5% 1608 R/TP
		R848	0RJ0471D677	4.7 OHM 1/10 W 5% 1608 R/TP
		R849	0RJ0471D677	4.7 OHM 1/10 W 5% 1608 R/TP
OTHERS				
		X501	6212AA2004A	HC-49U TXC 12.0MHZ +/- 30 PP
CONTROL BOARD				
		LED1	0DLBE0028AA	BRIGHT LED ELECTRONICS BL-HK
		R1	0RJ4701D677	4.7K OHM 1/10 W 5% 1608 R/TP
		R2	0RJ4701D677	4.7K OHM 1/10 W 5% 1608 R/TP
		R3	0RJ1501D677	1.5K OHM 1/10 W 5% 1608 R/TP
		R4	0RJ1501D677	1.5K OHM 1/10 W 5% 1608 R/TP
		R5	0RJ3301D677	3.3K OHM 1/10 W 5% 1608 R/TP
		R6	0RJ3301D677	3.3K OHM 1/10 W 5% 1608 R/TP
		R7	0RJ9101D677	9.1K OHM 1/10 W 5% 1608 R/TP
		SW1	140-058E	SKHV10910B LGEC NON 12V 20A
		SW2	140-058E	SKHV10910B LGEC NON 12V 20A
		SW3	140-058E	SKHV10910B LGEC NON 12V 20A
		SW4	140-058E	SKHV10910B LGEC NON 12V 20A
		SW5	140-058E	SKHV10910B LGEC NON 12V 20A
		SW6	140-058E	SKHV10910B LGEC NON 12V 20A
		SW7	140-058E	SKHV10910B LGEC NON 12V 20A
		ZD1	0DZ560009GB	BZT52C5V6S DIODES R/TP SOD32
		ZD2	0DZ560009GB	BZT52C5V6S DIODES R/TP SOD32
USB BOARD				
		C1	0CH8107F611	100UF 16V M 85STD(CYL) R/TP
		C6	0CH3105F946	1UF 16V Z F 2012 R/TP
		C8	0CC150CK41A	15PF 1608 50V 5% R/TP NP0
		C9	0CC150CK41A	15PF 1608 50V 5% R/TP NP0
		C2	0CK103CK51A	0.01UF 1608 50V 10% R/TP B(Y)
		C18	0CK104CK56A	0.1UF 1608 50V 10% R/TP X7R
		C23	0CH8107F611	100UF 16V M 85STD(CYL) R/TP
		C24	0CC470CK41A	47PF 1608 50V 5% R/TP NP0
		C25	0CC470CK41A	47PF 1608 50V 5% R/TP NP0
		C27	0CH8107F611	100UF 16V M 85STD(CYL) R/TP
		C28	0CK103CK51A	0.01UF 1608 50V 10% R/TP B(Y)
		C31	0CK104CK56A	0.1UF 1608 50V 10% R/TP X7R
		C32	0CK104CK56A	0.1UF 1608 50V 10% R/TP X7R

PIN CONFIGURATION

CAT24WC02J-TE13 8P

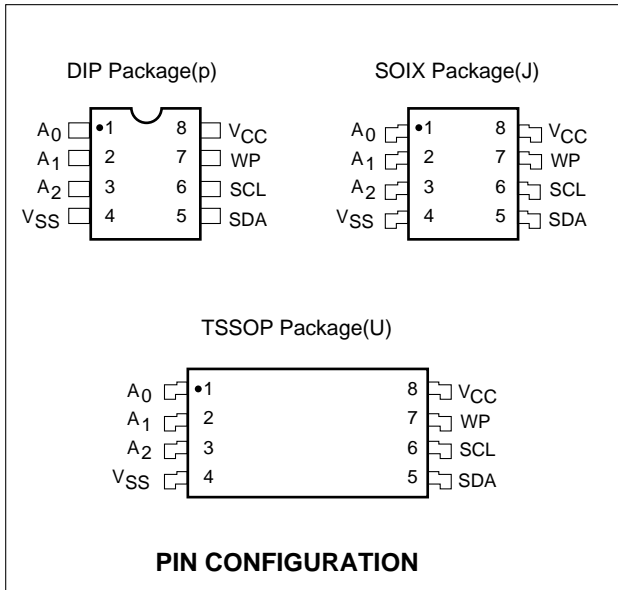

PIN FUNCTION

Pin Name	Function
A ₀ , A ₁ , A ₂	Device Address Inputs
SDA	Serial Data/Address
SCL	Serial Clock
WP	Write Protect
V _{cc}	+1.8V to + 6.0V power Supply
V _{ss}	Ground

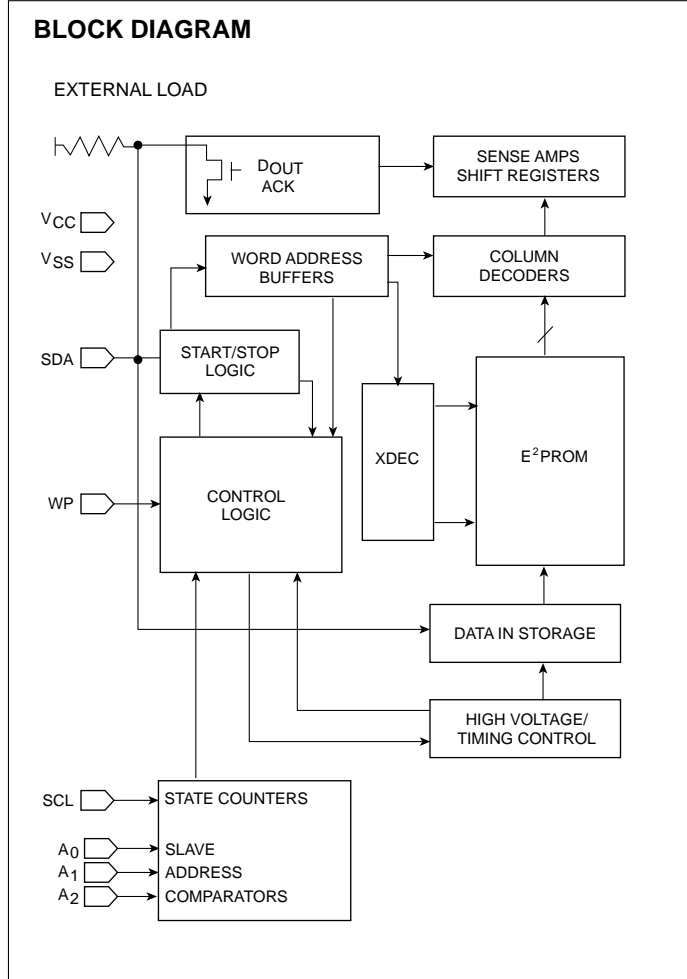

MST9011 ANALOG MSTAR 128P

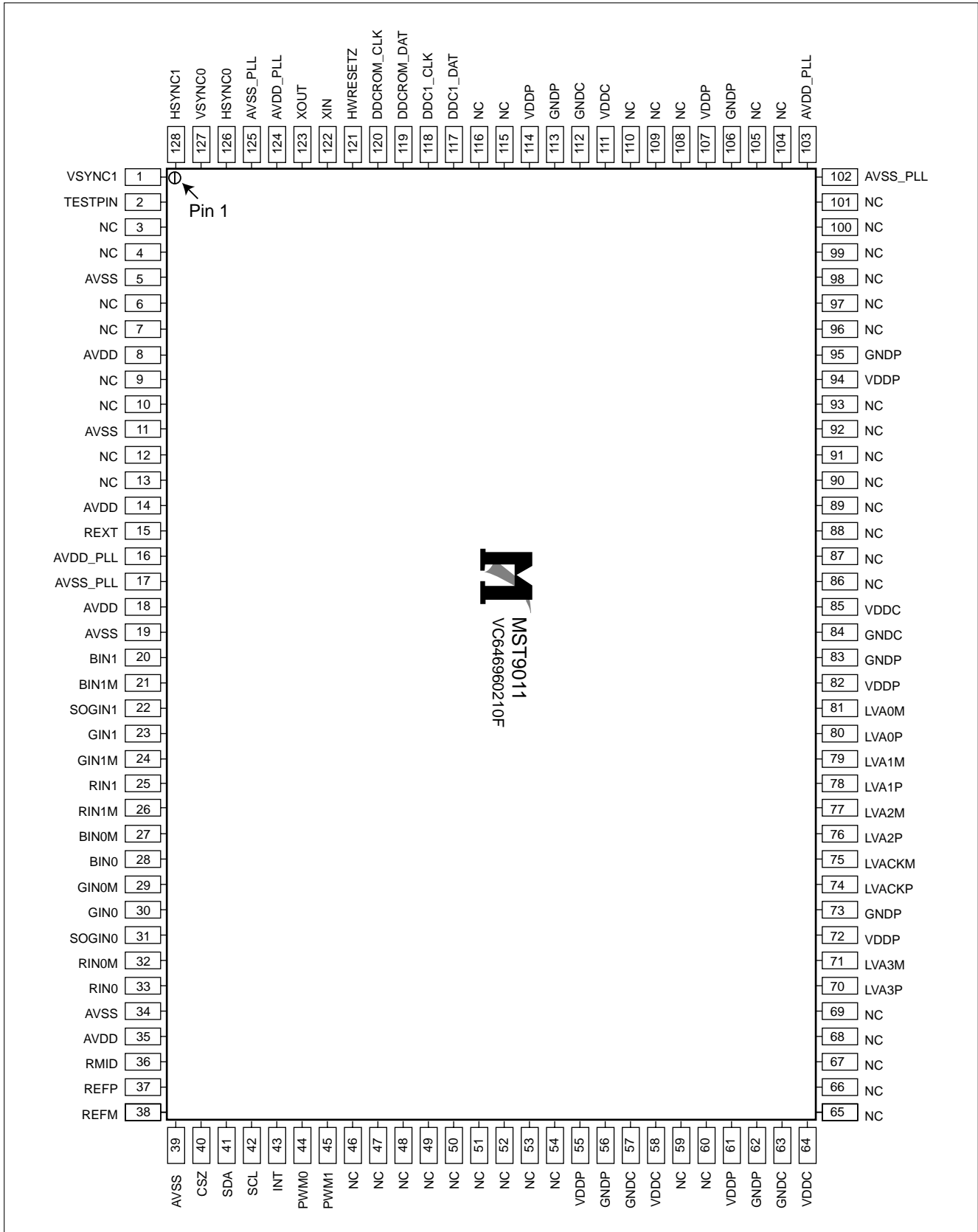

SCHEMATIC DIAGRAM

1. SCALER

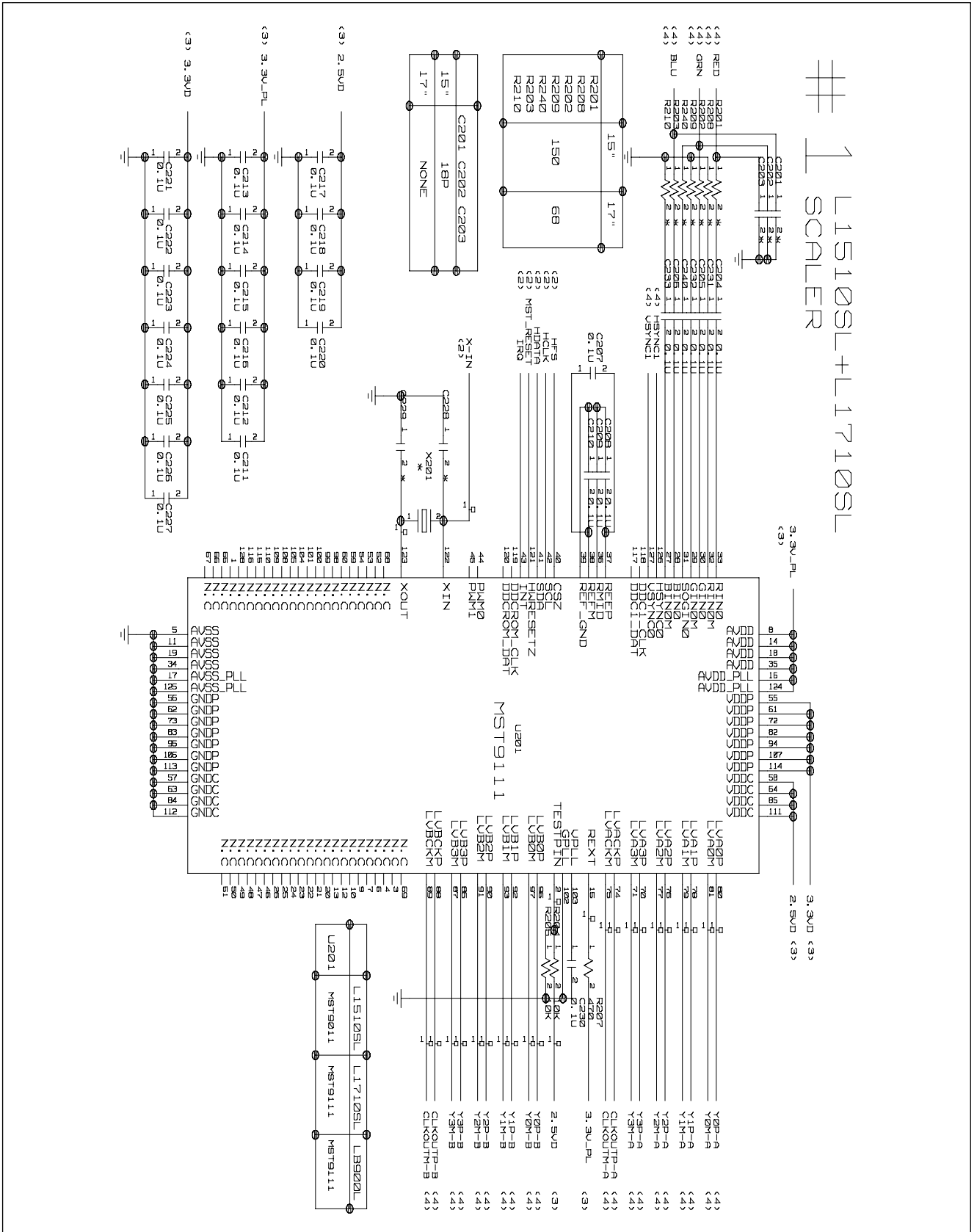

2. MICOM

#2 L1510SL+L1710SL

MICOM

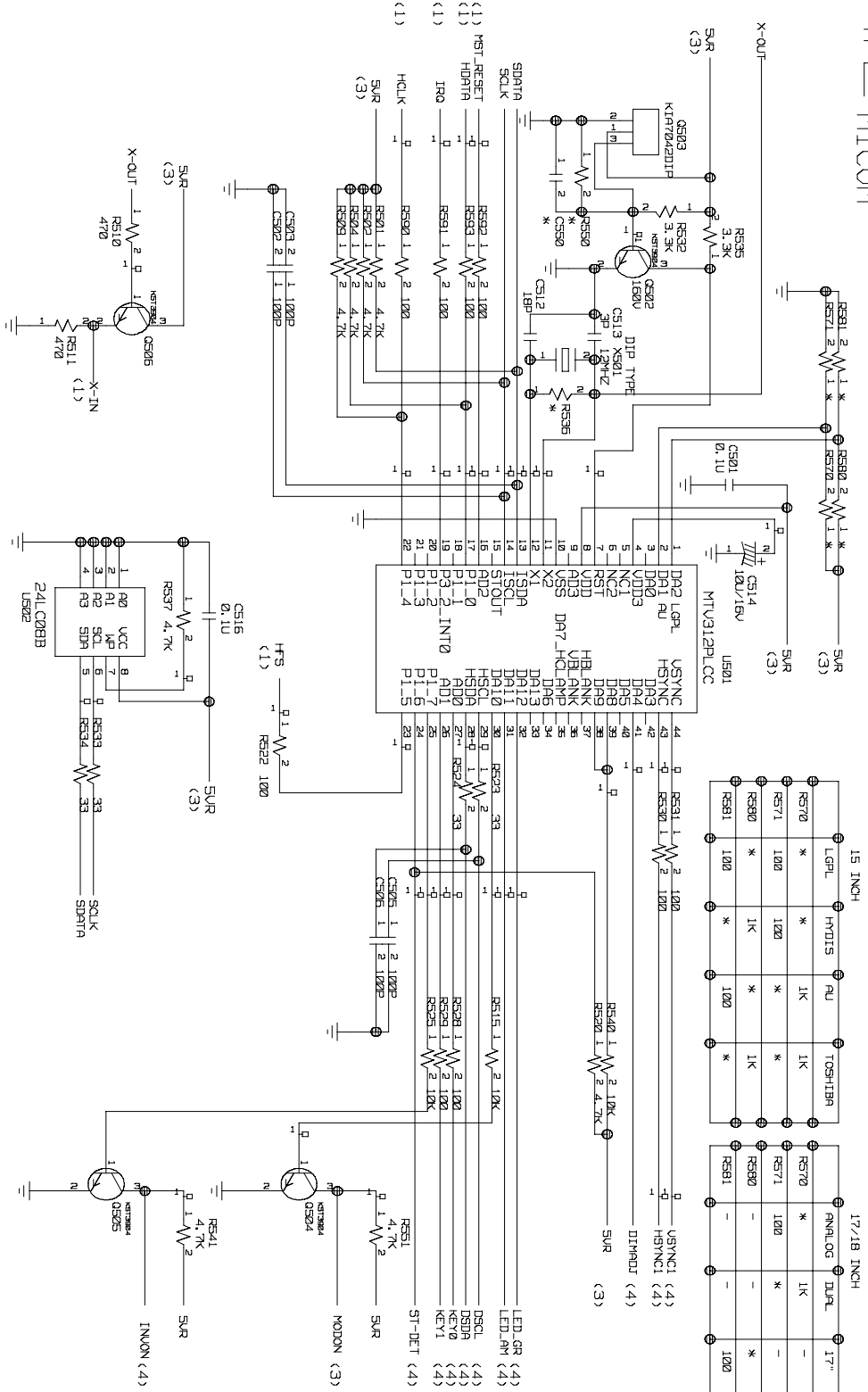

4. CONNECTOR & JACKS

4 CON1510SL+1710SL CONNECTOR & JACKS

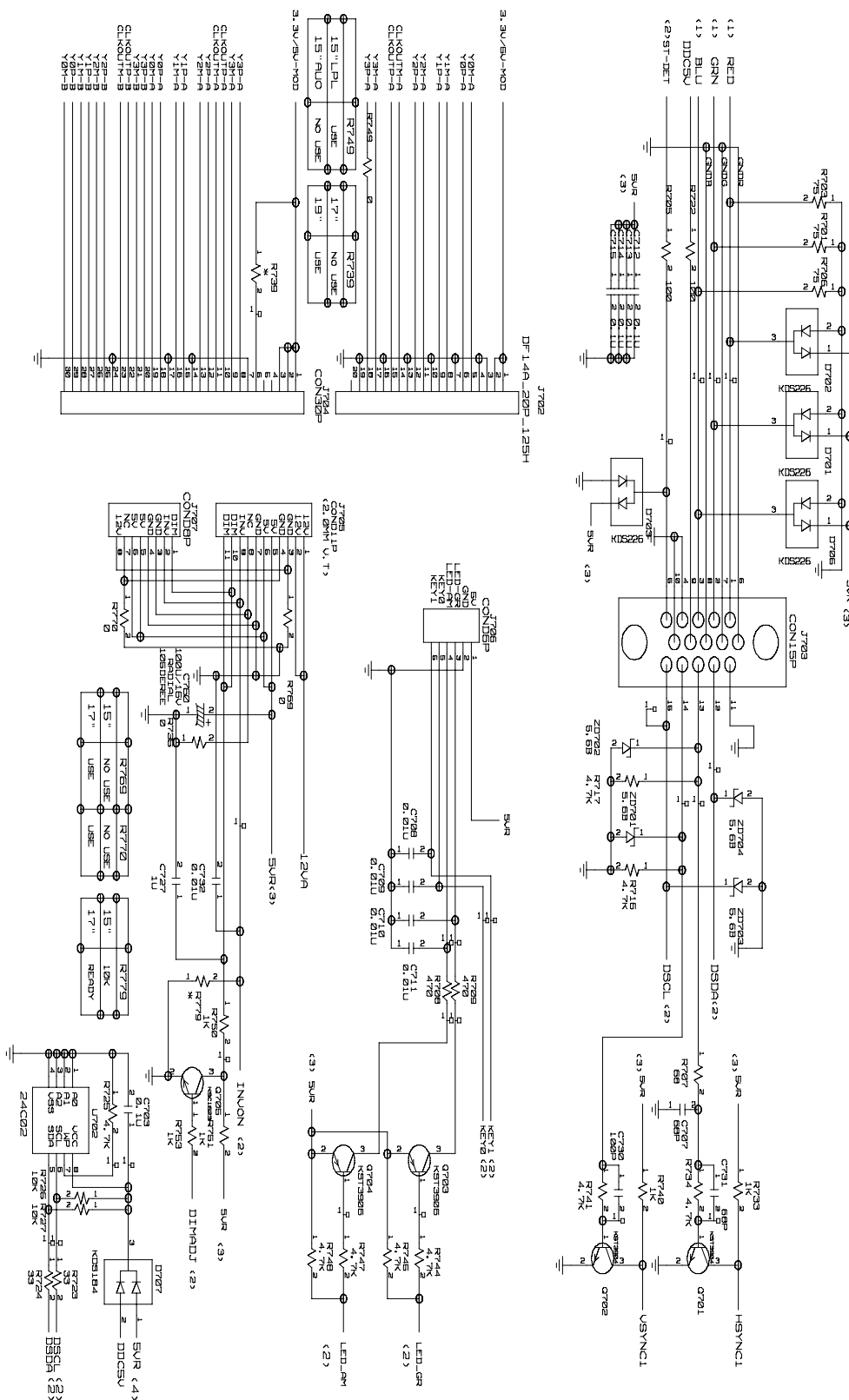

5. KEY PART

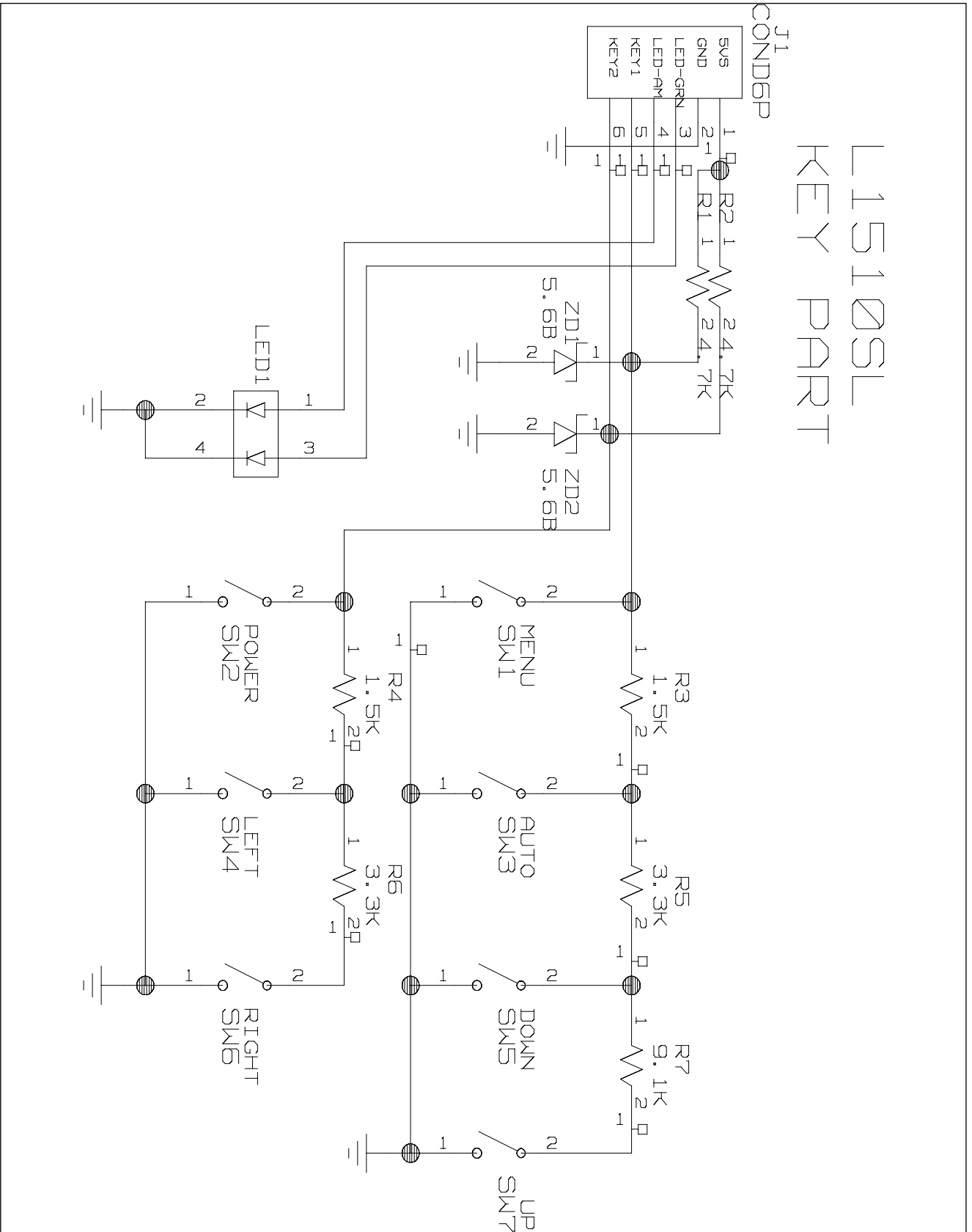



P/NO : 3828TSL083Y

May. 2003
Printed in Korea

