

Service
Service
Service



Service Manual

TABLE OF CONTENTS

	Page		
SECTION 1 SUMMARY	1-1	VDR Part	
Product safety servicing guidelines for		VDR Electrical Troubleshooting Guide	3-71
Video Products	1-2	Block Diagrams	3-78
Servicing Precautions	1-3	Circuit Diagrams	3-85
The steps for change the option code	1-4	Printed Circuit Diagrams	3-107
Up-dating Programs	1-5		
Specifications	1-7	RL-02A Loader Part (Non-Repairable Module - For information only)	
SECTION 2 EXPLODED VIEWS	2-1	RL-02A Loader Electrical Troubleshooting Guide ..	3-114
Cabinet and Main Frame Section	2-2	The difference between DVD-R/RW, DVD+R/RW	
RL-02A Deck Mechanism (For information only)	2-3	discs and DVD-ROM	3-146
Packing Accessory Section	2-4	How to use test tool (For information only)	3-155
		Block Diagrams (For information only)	3-163
SECTION 3 ELECTRICAL	3-1	Circuit Diagrams (For information only)	3-167
Overall Wiring Diagram	3-2	Printed Circuit Diagrams (For information only)	3-179
VCR Part (includes SMPS Power, Jack, Key & Timer board)		SECTION 4 MECHANISM OF VCR PART (D-37) ...	4-1
Electrical Adjustment Procedures	3-4	SECTION 5 SERVICE PARTS LIST	5-1
VCR Electrical Troubleshooting Guide	3-5	SECTION 6 REVISION LIST	6-1
Block Diagrams	3-21		
Circuit Diagrams	3-35		
Printed Circuit Diagrams	3-59		

© Copyright 2004 Philips Consumer Electronics B.V. Eindhoven, The Netherlands
 All rights reserved. No part of this publication may be reproduced, stored in a retrieval system or transmitted, in any form or by any means, electronic, mechanical, photocopying, or otherwise without the prior permission of Philips.

Published by LG-KC 0435 AV System Printed in The Netherlands Subject to modification

 3139 785 30781

Version 1.1



PHILIPS

SECTION 1

SUMMARY

CONTENTS

PRODUCT SAFETY SERVICING GUIDELINES FOR VIDEO PRODUCTS	1-2
SERVICING PRECAUTIONS	1-3
THE STEPS FOR CHANGE THE OPTION CODE	1-4
UP-DATING PROGRAM	1-5
SPECIFICATIONS	1-7

PRODUCT SAFETY SERVICING GUIDELINES FOR VIDEO PRODUCTS

IMPORTANT SAFETY NOTICE

This manual was prepared for use only by properly trained audio-video service technicians.

When servicing this product, under no circumstances should the original design be modified or altered without permission from PHILIPS Electronics Corporation. All components should be replaced only with types identical to those in the original circuit and their physical location, wiring and lead dress must conform to original layout upon completion of repairs.

Special components are also used to prevent x-radiation, shock and fire hazard. These components are indicated by the letter "x" included in their component designators and are required to maintain safe performance. No deviations are allowed without prior approval by PHILIPS Electronics Corporation.

Circuit diagrams may occasionally differ from the actual circuit used. This way, implementation of the latest safety and performance improvement changes into the set is not delayed until the new service literature is printed.

CAUTION: Do not attempt to modify this product in any way. Never perform customized installations without manufacturer's approval. Unauthorized modifications will not only void the warranty, but may lead to property damage or user injury.

Service work should be performed only after you are thoroughly familiar with these safety checks and servicing guidelines.

GRAPHIC SYMBOLS



The exclamation point within an equilateral triangle is intended to alert the service personnel to important safety information in the service literature.



The lightning flash with arrowhead symbol within an equilateral triangle is intended to alert the service personnel to the presence of noninsulated "dangerous voltage" that may be of sufficient magnitude to constitute a risk of electric shock.



The pictorial representation of a fuse and its rating within an equilateral triangle is intended to convey to the service personnel the following fuse replacement caution notice:

CAUTION: FOR CONTINUED PROTECTION AGAINST RISK OF FIRE, REPLACE ALL FUSES WITH THE SAME TYPE AND RATING AS MARKED NEAR EACH FUSE.

SERVICE INFORMATION

While servicing, use an isolation transformer for protection from AC line shock. After the original service problem has been corrected, make a check of the following:

FIRE AND SHOCK HAZARD

1. Be sure that all components are positioned to avoid a possibility of adjacent component shorts. This is especially important on items transported to and from the repair shop.
2. Verify that all protective devices such as insulators, barriers, covers, shields, strain reliefs, power supply cords, and other hardware have been reinstalled per the original design. Be sure that the safety purpose of the polarized line plug has not been defeated.
3. Soldering must be inspected to discover possible cold solder joints, solder splashes, or sharp solder points. Be certain to remove all loose foreign particles.
4. Check for physical evidence of damage or deterioration to parts and components, for frayed leads or damaged insulation (including the AC cord), and replace if necessary.
5. No lead or component should touch a high current device or a resistor rated at 1 watt or more. Lead tension around protruding metal surfaces must be avoided.
6. After reassembly of the set, always perform an AC leakage test on all exposed metallic parts of the cabinet (the channel selector knobs, antenna terminals, handle and screws) to be sure that set is safe to operate without danger of electrical shock. **DO NOT USE A LINE ISOLATION TRANSFORMER DURING THIS TEST.** Use an AC voltmeter having 5000 ohms per volt or more sensitivity in the following manner: Connect a 1500 ohm, 10 watt resistor, paralleled by a .15 mfd 150V AC type capacitor between a known good earth ground water pipe, conduit, etc.) and the exposed metallic parts, one at a time. Measure the AC voltage across the combination of 1500 ohm resistor and .15 mfd capacitor. Reverse the AC plug by using a non-polarized adaptor and repeat AC voltage measurements for each exposed metallic part. Voltage measured must not exceed 0.75 volts RMS. This corresponds to 0.5 milliamp AC. Any value exceeding this limit constitutes a potential shock hazard and must be corrected immediately.

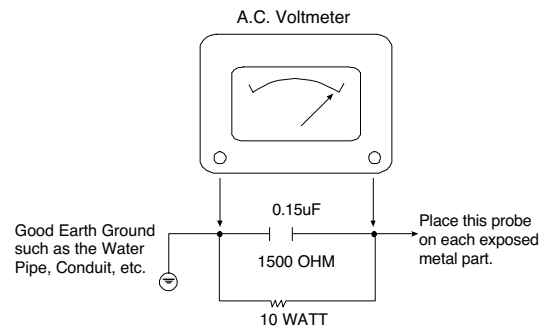

TIPS ON PROPER INSTALLATION

1. Never install any receiver in a closed-in recess, cubbyhole, or closely fitting shelf space over, or close to, a heat duct, or in the path of heated air flow.
2. Avoid conditions of high humidity such as: outdoor patio installations where dew is a factor, near steam radiators where steam leakage is a factor, etc.
3. Avoid placement where draperies may obstruct venting. The customer should also avoid the use of decorative scarves or other coverings that might obstruct ventilation.
4. Wall- and shelf-mounted installations using a commercial mounting kit must follow the factory-approved mounting instructions. A product mounted to a shelf or platform must retain its original feet (or the equivalent thickness in spacers) to provide adequate air flow across the bottom. Bolts or screws used for fasteners must not touch any parts or wiring. Perform leakage tests on customized installations.
5. Caution customers against mounting a product on a sloping shelf or in a tilted position, unless the receiver is properly secured.
6. A product on a roll-about cart should be stable in its mounting to the cart. Caution the customer on the hazards of trying to roll a cart with small casters across thresholds or deep pile carpets.
7. Caution customers against using extension cords. Explain that a forest of extensions, sprouting from a single outlet, can lead to disastrous consequences to home and family.

SERVICING PRECAUTIONS

CAUTION: Before servicing the VCR + DVD RECORDER covered by this service data and its supplements and addends, read and follow the SAFETY PRECAUTIONS. NOTE: if unforeseen circumstances create conflict between the following servicing precautions and any of the safety precautions in this publications, always follow the safety precautions.

Remember Safety First:

General Servicing Precautions

1. Always unplug the VCR + DVD RECORDER AC power cord from the AC power source before:
 - (1) Removing or reinstalling any component, circuit board, module, or any other assembly.
 - (2) Disconnecting or reconnecting any internal electrical plug or other electrical connection.
 - (3) Connecting a test substitute in parallel with an electrolytic capacitor.
Caution: A wrong part substitution or incorrect polarity installation of electrolytic capacitors may result in an explosion hazard.
2. Do not spray chemicals on or near this VCR + DVD RECORDER or any of its assemblies.
3. Unless specified otherwise in this service data, clean electrical contacts by applying an appropriate contact cleaning solution to the contacts with a pipe cleaner, cotton-tipped swab, or comparable soft applicator. Unless specified otherwise in this service data, lubrication of contacts is not required.
4. Do not defeat any plug/socket B+ voltage interlocks with which instruments covered by this service manual might be equipped.
5. Do not apply AC power to this VCR + DVD RECORDER and / or any of its electrical assemblies unless all solid-state device heat sinks are correctly installed.
6. Always connect the test instrument ground lead to an appropriate ground before connecting the test instrument positive lead. Always remove the test instrument ground lead last.

Insulation Checking Procedure

Disconnect the attachment plug from the AC outlet and turn the power on. Connect an insulation resistance meter (500V) to the blades of the attachment plug. The insulation resistance between each blade of the attachment plug and accessible conductive parts (Note 1) should be more than 1M-ohm.

Note 1: Accessible Conductive Parts include Metal panels, Input terminals, Earphone jacks, etc.

Electrostatically Sensitive (ES) Devices

Some semiconductor (solid state) devices can be damaged easily by static electricity. Such components commonly are called Electrostatically Sensitive (ES) Devices. Examples of typical ES devices are integrated circuits and some field effect transistors and semiconductor chip components.

The following techniques should be used to help reduce the incidence of component damage caused by static electricity.

1. Immediately before handling any semiconductor component or semiconductor-equipped assembly, drain off any electrostatic charge on your body by touching a known earth ground. Alternatively, obtain and wear a commercially available discharging wrist strap device, which should be removed for potential shock reasons prior to applying power to the unit under test.
2. After removing an electrical assembly equipped with ES devices, place the assembly on a conductive surface such as aluminum foil, to prevent electrostatic charge buildup or exposure of the assembly.
3. Use only a grounded-tip soldering iron to solder or unsolder ES devices.
4. Use only an anti-static solder removal device. Some solder removal devices not classified as "anti-static" can generate electrical charges sufficient to damage ES devices.
5. Do not use freon-propelled chemicals. These can generate an electrical charge sufficient to damage ES devices.
6. Do not remove a replacement ES device from its protective package until immediately before you are ready to install it. (Most replacement ES devices are packaged with leads electrically shorted together by conductive foam, aluminum foil, or comparable conductive material).
7. Immediately before removing the protective material from the leads of a replacement ES device, touch the protective material to the chassis or circuit assembly into which the device will be installed.

Caution: Be sure no power is applied to the chassis or circuit, and observe all other safety precautions.

8. Minimize bodily motions when handling unpackaged replacement ES devices. (Normally harmless motion such as the brushing together of your clothes fabric or the lifting of your foot from a carpeted floor can generate static electricity sufficient to damage an ES device.)

THE STEPS FOR CHANGE THE OPTION CODE

Note : This procedure must be done when IC304(On digital Board) or Digital Board assy is replaced.

Push Switch POWER ON/ OFF
at remocon or timer keyborad

Select DVD MODE at the set
use remocon or timer keyborad

Push REC+ PLAY
at timer keyboard

Use remocon and push ENTER

Use Direction Key at
remocon (LEFT/ RIGHT)
for select the position of option

Use Direction Key
at remocon (UP/ DOWN)
for change the option

After finish edit code of option
push ENTER at remocon

For finishing and intialized
the option code push
REC+ FF at remocon

DETECT NEW EEPROM (OPTION EDIT SCREEN)

DVDR630VR/14
NAME HEX
 OPT1 22
 OPT2 48
 OPT3 55
 OPT4 95
 OPT5 26
 OPT6 9E
 OPT7 D6
 OPT8 D3

DVDR630VR/05
NAME HEX
 OPT1 12
 OPT2 47
 OPT3 42
 OPT4 95
 OPT5 26
 OPT6 9E
 OPT7 F6
 OPT8 D1

DVDR630VR/00
NAME HEX
 OPT1 12
 OPT2 44
 OPT3 45
 OPT4 95
 OPT5 26
 OPT6 9E
 OPT7 F6
 OPT8 30

DVDR630VR/02
NAME HEX
 OPT1 02
 OPT2 46
 OPT3 52
 OPT4 95
 OPT5 26
 OPT6 9E
 OPT7 FE
 OPT8 68

Press "Enter" key
to Save and Exit

UP-DATING PROGRAM

BURNING DISC

- For up-dating the DVD program using the disc, it must burning the disc which include the DVD software.
- For recorder combi set which using the disc downloader program are DVD Program and Loader Program.
- In 2nd generation for recorder combi can download the DVD program and Loader program one by one, or all together.

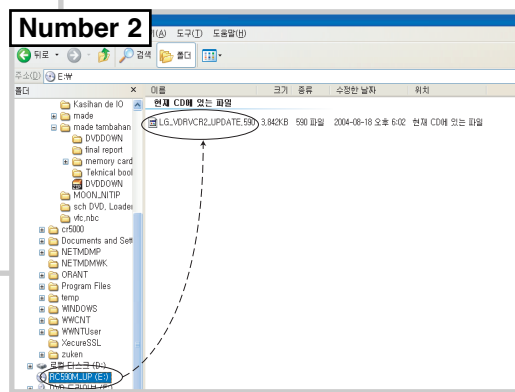
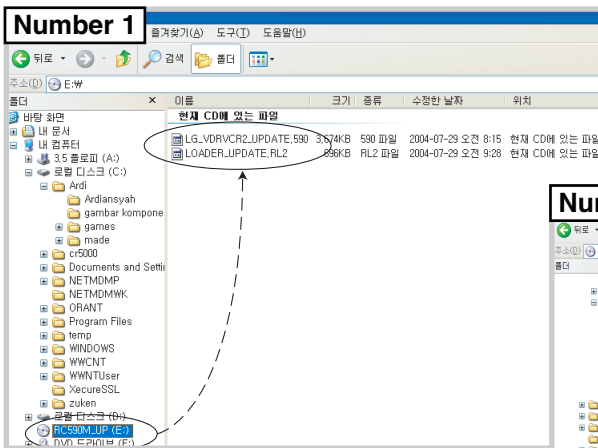

- * There is two way to format disc DVD Program
1. DVD and LOADER program format in one disc
 2. Only DVD program format in one disc

- If you format like number 1 you'll see capture like (figure 1)
- And you have three choice:
 1. Main. It's mean if you chose this it'll up-dating only DVD prgram.
 2. Loader. It's mean if you chose this it'll up-dating only Loader program.
 3. ALL. It's mean if you chose this it'll up-dating DVD and Loader program.



- If you format like number 2 you'll not see capture like figure 1 that give you choices, you have no choice only update DVD program

DVD UPGRADE INSTRUCTION

FORMAT NO 1

1. Press POWER KEY to turn on.
2. After booting, insert the upgrade disc, and you will see message like [FIGURE 1]
3. Press “REC” key (front or remote) 3 times and you will see as [FIGURE 2] with remote Chose one of them then Press enter
4. For update both of them [MAIN & LOADER] we chose “ALL” and first you will see [FIGURE 3] DVD update
→ Check the “Current Version” and “New CD Write Version” and press “REC” key.
5. The DVD update will be on progress. And when finish update MAIN Version it’s automatically continue to Update Loader Version and You will see [FIGURE 4]
→ Check the “Current Version” and “New CD Write Version “ and Press “REC” key once more
6. The LOADER update will be on progress. And tray will open.
7. Remove the disc and wait until finish
8. The tray will be close and open automatically after completing “UNDER UPDATE” 100%
9. Turn off the unit
10. Turn on again the unit is operation with new software

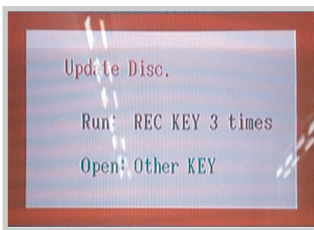

[FIGURE 1]

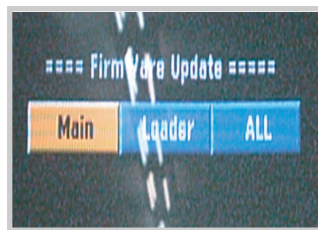

[FIGURE 2]

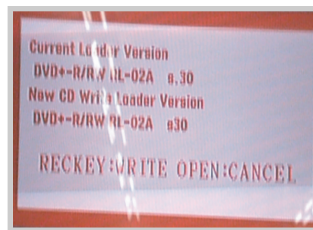

[FIGURE 3]

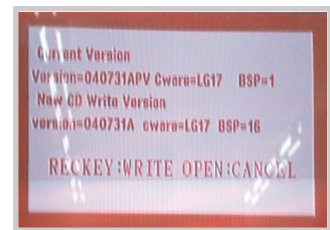

[FIGURE 4]

FORMAT NO 2

1. Press POWER KEY to turn on.
2. After booting, insert the upgrade disc, and you will see message like [FIGURE 1]
3. Press “REC” key (front or remote) 3 times
4. The DVD update will be on progress.
→ Check the “Current Version” and “New CD Write Version “ and Press “REC” key once more
5. The tray will be open automatically after completing “UNDER UPDATE” 100%
6. Remove the disc and Turn off the unit
7. Turn on again the unit is operation with new software

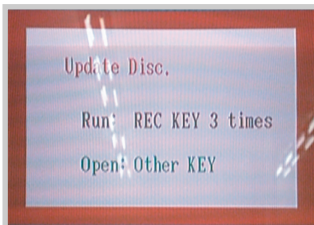

[FIGURE 1]

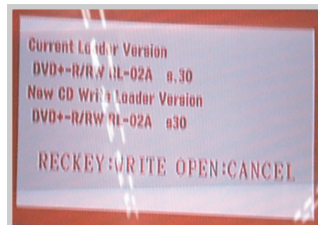

[FIGURE 2]

SPECIFICATIONS

General

Power requirements	AC 220-230V, 50 Hz
Power consumption	35W
Dimensions (approx.)	430 X 78.5 X 354 mm (w x h x d)
Mass (approx.)	5.7 kg
Operating temperature	5°C to 35°C
Operating humidity	5 % to 90 %
Television system	PAL B/G, PAL I/I, SECAM D/K color system
Recording format	PAL

System

Laser	Semiconductor laser, wavelength 650 nm
Video head system	Double azimuth 4 heads, helical scanning
Signal system	PAL

Recording

Recording format	DVD+RW/+R Video format
Recordable discs	DVD-ReWritable, DVD-Recordable, DVD+ReWritable, DVD+Recordable
Recordable time	Approx. 1 hour (XP mode), 2 hours (SP mode), 4 hours (LP mode), 6 hours (EP mode)

Video recording format

Sampling frequency	27MHz
Compression format	MPEG 2

Audio recording format

Sampling frequency	48kHz
Compression format	Dolby Digital

Playback

Frequency response	DVD (PCM 48 kHz): 8 Hz to 22 kHz, CD: 8 Hz to 20 kHz DVD (PCM 96 kHz): 8 Hz to 44 kHz
Harmonic distortion	Less than 0.008% (AUDIO OUT connector)
Dynamic range	More than 95 dB (AUDIO OUT connector)

Inputs

AERIAL IN	Aerial input, 75 ohms
VIDEO IN	1.0 Vp-p 75 ohms, sync negative, RCA jack x 1 / SCART x 2
AUDIO IN	0 dBm more than 47 kohms, RCA jack (L, R) x 1 / SCART x 2
DV IN	4 pin (i.LINK/IEEE 1394 standard)
S-VIDEO IN	(Y) 1.0 V (p-p), 75 Ω, negative sync, Mini DIN 4-pin x 1 (C) 0.3 V (p-p) 75 Ω

Outputs

S-VIDEO OUT	(Y) 1.0 V (p-p), 75 Ω, negative sync, Mini DIN 4-pin x 1 (C) 0.3 V (p-p) 75 Ω
COMPONENT VIDEO OUT	(Y) 1.0 V (p-p), 75 Ω, negative sync, RCA jack x 1 (Pb)/(Pr) 0.7 V (p-p), 75 Ω, RCA jack x 2
Audio output (digital audio)	0.5 V (p-p), 75 Ω, RCA jack x 1
Audio output (analog audio)	2.0 Vrms (1 KHz, 0 dB), 600 Ω, RCA jack (L, R) x 1 / SCART

* Design and specifications are subject to change without notice.

* Manufactured under license from Dolby Laboratories. "Dolby", "Pro Logic" and the double-D symbol are trademarks of Dolby Laboratories.

* DTS and DTS Digital Out are registered trademarks of Digital Theater Systems, Inc.

MEMO

A series of horizontal dotted lines for writing, spaced evenly down the page.

SECTION 2
EXPLODED VIEWS

CONTENTS

EXPLODED VIEWS2-2

- 1. Cabinet and Main Frame Section2-2**
- 2. Deck Mechanism Section (RL-02A) (For information only).....2-3**
- 3. Packing Accessory Section.....2-4**

EXPLODED VIEWS

1. Cabinet and Main Frame Section

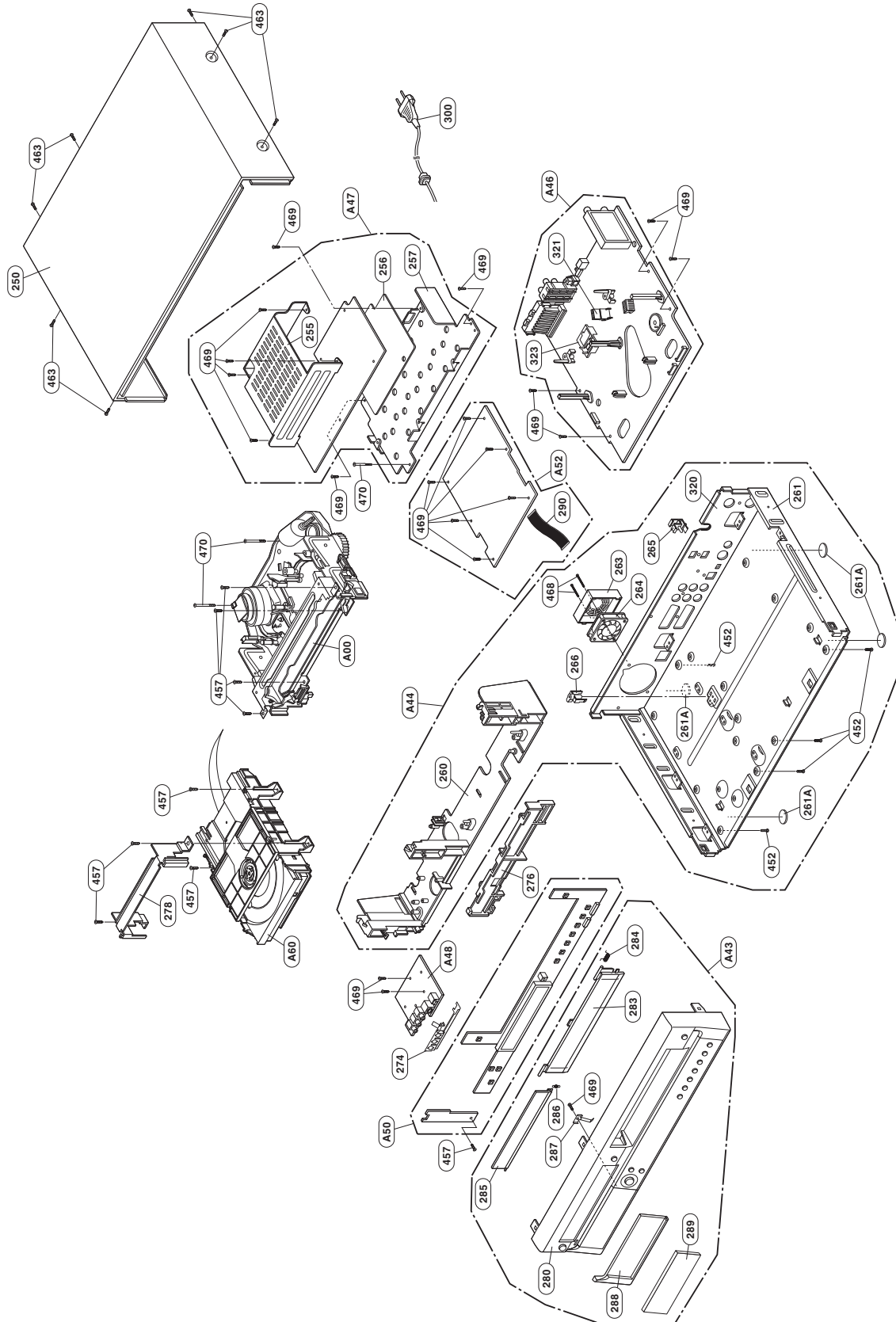

2. Deck Mechanism Section (RL-02A) - For information only

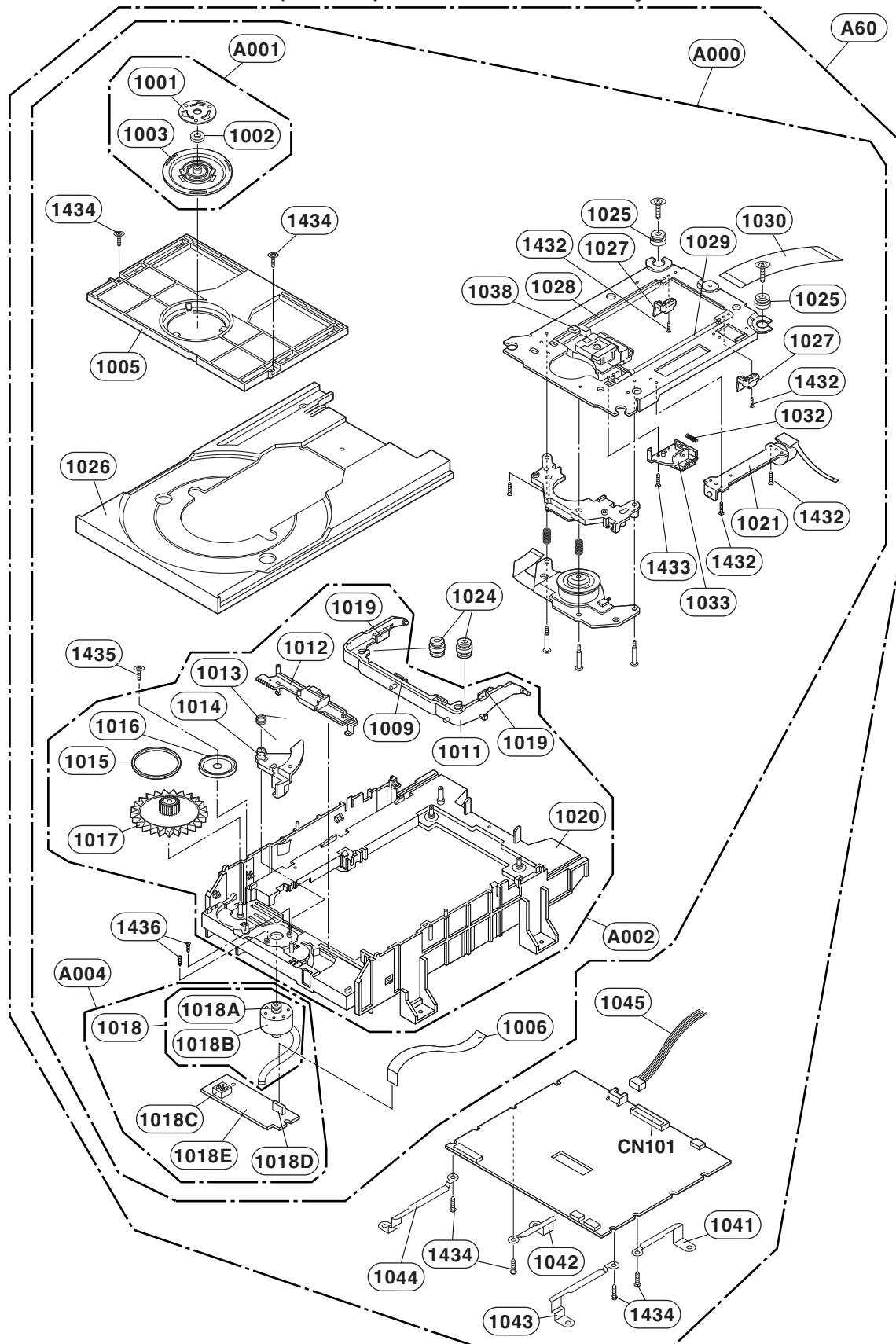

3. Packing Accessory Section

★ OPTIONAL PARTS

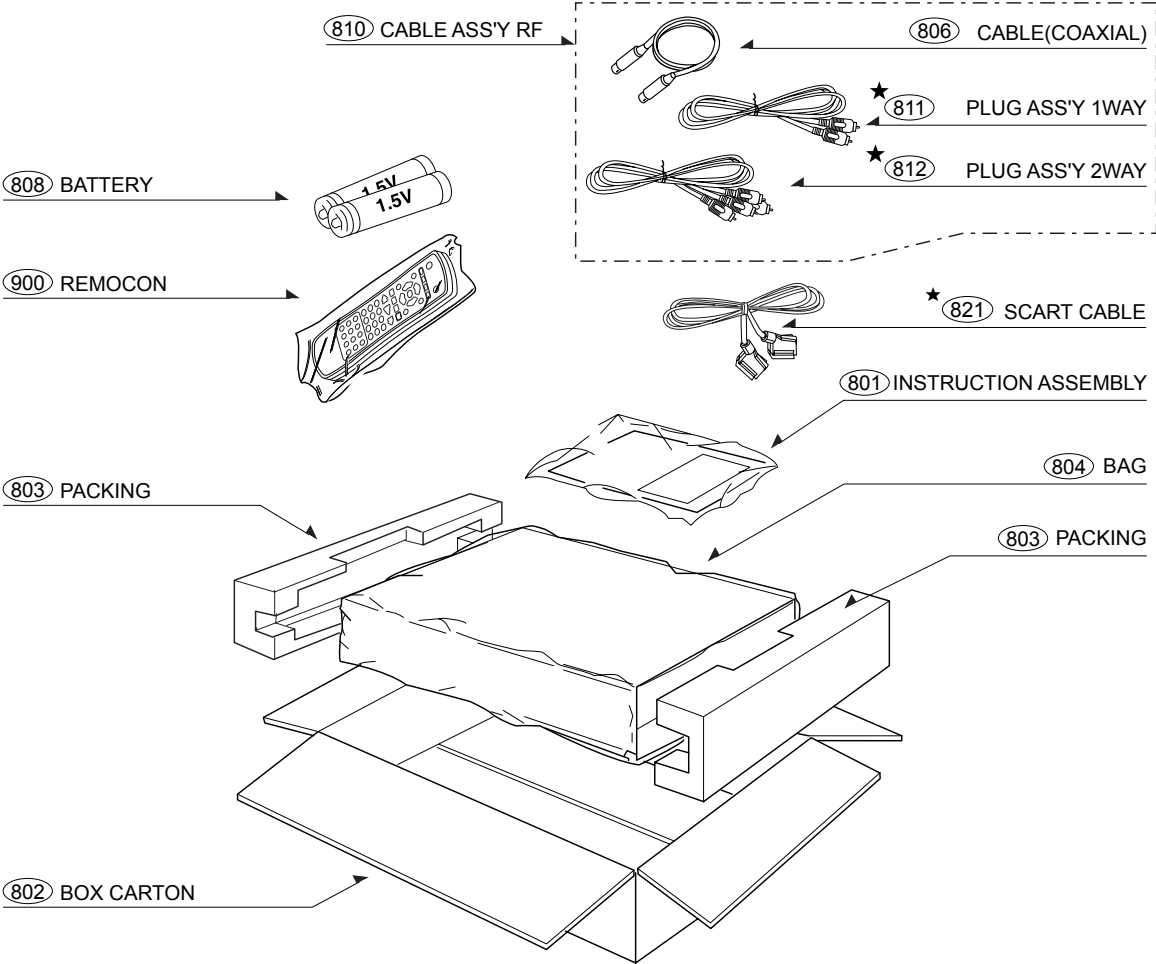

SECTION 3 ELECTRICAL CONTENTS

<p>OVERALL WIRING DIAGRAM 3-2</p> <p>VCR PART (includes SMPS Power, Jack, Key & Timer boards)</p> <p>VCR ELECTRICAL ADJUSTMENT PROCEDURES 3-4</p> <p>VCR ELECTRICAL TROUBLESHOOTING GUIDE 3-5</p> <ol style="list-style-type: none"> 1. POWER (SMPS) CIRCUIT 3-5 2. SYSTEM/KEY CIRCUIT 3-8 3. SERVO CIRCUIT 3-9 4. Y/C CIRCUIT 3-12 5. HI-FI CIRCUIT 3-16 6. TUNER/IF CIRCUIT 3-19 <p>BLOCK DIAGRAMS 3-21</p> <ol style="list-style-type: none"> 1. POWER (SMPS) BLOCK DIAGRAM 3-21 2. TUNER/IF, NICAM & A2 BLOCK DIAGRAM 3-23 3. VPS BLOCK DIAGRAM 3-24 4. Y/C BLOCK DIAGRAM 3-25 5. NORMAL AUDIO BLOCK DIAGRAM 3-27 6. HI-FI BLOCK DIAGRAM 3-29 7. SYSTEM BLOCK DIAGRAM 3-31 8. SCART & SWITCH BLOCK DIAGRAM 3-33 <p>CIRCUIT DIAGRAMS 3-35</p> <ol style="list-style-type: none"> 1. POWER (SMPS) CIRCUIT DIAGRAM 3-35 2. TUNER CIRCUIT DIAGRAM 3-37 3. A/V CIRCUIT DIAGRAM 3-39 4. HI-FI CIRCUIT DIAGRAM 3-41 5. SYSTEM CIRCUIT DIAGRAM 3-43 6. SCART (JACK) CIRCUIT DIAGRAM (SCART MODEL ONLY) 3-45 7. TIMER CIRCUIT DIAGRAM 3-47 * WAVEFORMS 3-49 * CIRCUIT VOLTAGE CHART 3-51 * IC BLOCK DIAGRAMS 3-55 <p>PRINTED CIRCUIT DIAGRAMS 3-59</p> <ol style="list-style-type: none"> 1. VCR P.C.BOARD (TOP VIEW) 3-59 2. VCR P.C.BOARD (BOTTOM VIEW) 3-63 3. SMPS P.C.BOARD 3-65 4. JACK P.C.BOARD 3-68 5. KEY & TIMER P.C.BOARD 3-69 	<p>VDR PART</p> <p>VDR ELECTRICAL TROUBLESHOOTING GUIDE 3-71</p> <ol style="list-style-type: none"> 1. POWER (SMPS) CIRCUIT 3-71 2. NO COMPONENT VIDEO SIGNAL WHEN PLAYING DISC 3-73 3. NO COMPOSITE / S-VIDEO SIGNAL WHEN PLAYING DISC 3-74 4. NO TV, EXTERNAL INPUT VIDEO SIGNAL 3-75 5. WHEN PLAYING DISC, NO AUDIO OUTPUT 3-76 6. NO TUNER AUDIO OUTPUT 3-76 7. NO OPTICAL / DIGITAL OUTPUT 3-76 8. NO EXTERNAL INPUT 1 AUDIO 3-77 9. NO EXTERNAL INPUT 2 AUDIO 3-77 <p>BLOCK DIAGRAMS 3-78</p> <ol style="list-style-type: none"> 1. VDR MAIN H/W BLOCK DIAGRAM 3-78 2. POWER BLOCK DIAGRAM 3-79 3. AUDIO IN/OUT BLOCK DIAGRAM 3-80 4. CPU & CONTROL REGISTER BLOCK DIAGRAM 3-81 5. VIDEO IN/OUT BLOCK DIAGRAM 3-82 6. DV 1394 IN/OUT BLOCK DIAGRAM 3-83 7. MEMORY CARD IN/OUT BLOCK DIAGRAM 3-84 <p>CIRCUIT DIAGRAMS 3-85</p> <ol style="list-style-type: none"> 1. BGA 308P CIRCUIT DIAGRAM 3-85 2. DDR & B TO B CONNECTOR CIRCUIT DIAGRAM 3-87 3. POWER, FLASH, CONNECTOR CIRCUIT DIAGRAM 3-89 4. RST, CONTROL/STATUS_REG., ATAPI, HOST_CPLD, LATCH CIRCUIT DIAGRAM 3-91 5. VIDEO_IN, VIDEO_OUT CIRCUIT DIAGRAM 3-93 6. DV1394, HDMI CIRCUIT DIAGRAM 3-95 7. AUDIO IN/OUT CIRCUIT DIAGRAM 3-97 * WAVEFORMS 3-99 * CIRCUIT VOLTAGE CHART 3-101 * IC BLOCK DIAGRAMS 3-103 <p>PRINTED CIRCUIT DIAGRAMS 3-107</p> <ol style="list-style-type: none"> 1. VDR P.C.BOARD (TOP VIEW) 3-107 2. VDR P.C.BOARD (BOTTOM VIEW) 3-111 <p>RL-02A LOADER PART (FOR INFORMATION ONLY) 3-113 TO 3-184</p>
---	---

MEMO

A series of horizontal dotted lines spanning the width of the page, providing a template for writing a memo.

OVERALL WIRING DIAGRAMS

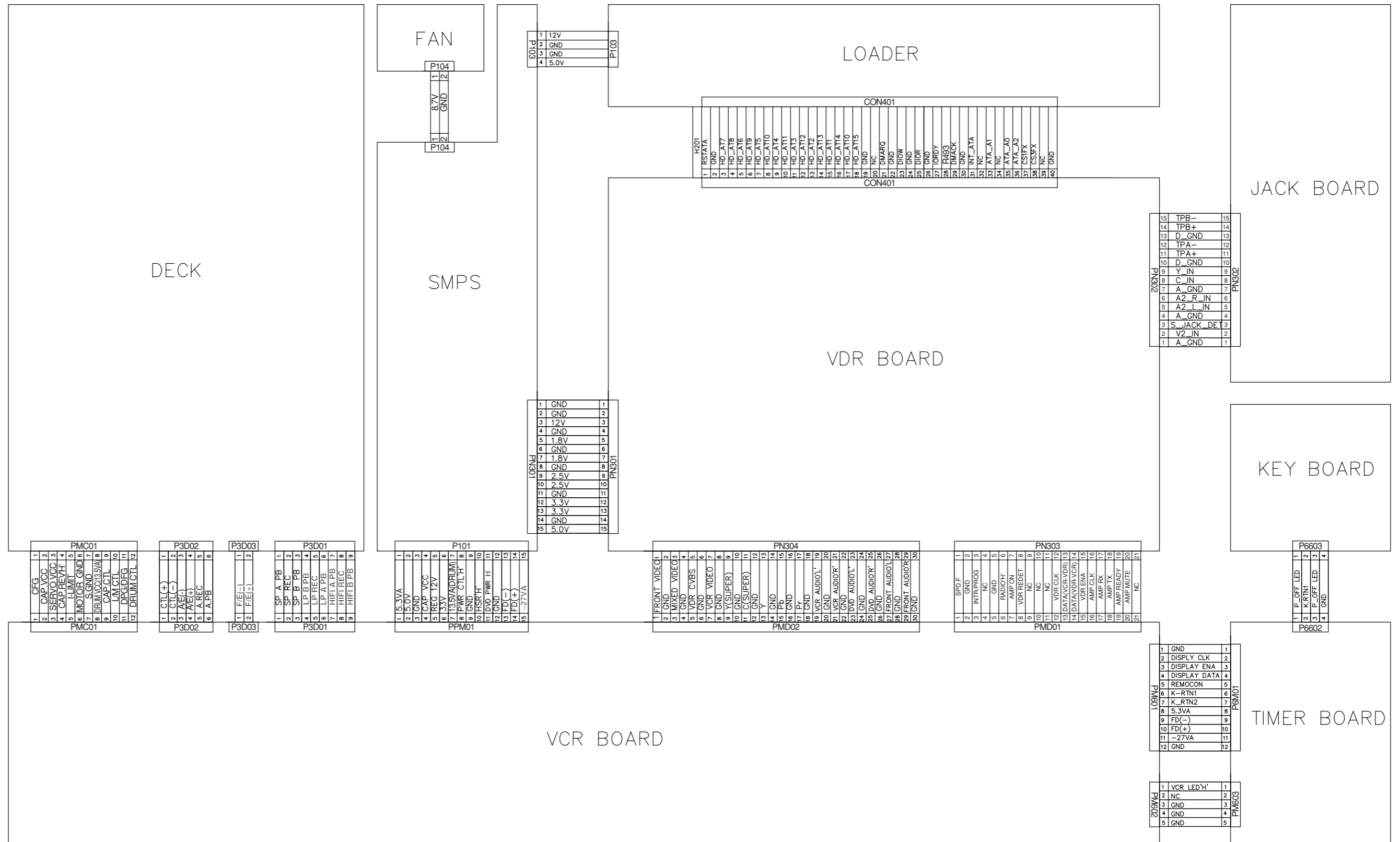

VCR PART

ELECTRICAL ADJUSTMENT PROCEDURES

1. Servo Adjustment

1) PG Adjustment

- Test Equipment
- a) OSCILLOSCOPE : PAL SP TEST TAPE

• Adjustment And Specification

MODE	MEASUREMENT POINT	ADJUSTMENT POINT	SPECIFICATION
PLAY	V.Out H/SW(TP)	R/C TRK JIG KEY	$6.5 \pm 0.5H$

• Adjustment Procedure

- a) Insert the SP Test Tape and play.
- b) Connect the CH1 of the oscilloscope to the H/SW and CH2 to the "VCR VIDEO" TP for the VCR.
- c) Trigger the mixed Combo Video Signal of CH2 to the CH1 H/SW, and then check the distance (time difference), which is from the selected A(B) Head point of the H/SW signal to the starting point of the vertical synchronized signal, to $6.5H \pm 0.5H$ ($416\mu s$, $1H=64\mu s$).

• PG Adjustment Method

- a-1) Playback the SP standard tape
- b-2) Wait for 3seconds with F/P "REC" key and "PLAY" key pressed at the same time. < Digitron[- -] >
- c-3) Repeat the above step(No.b-2), then it finishes the PG adjusting automatically. < Digitron[PG] >
- d-4) Stop the playback, then it goes out of PG adjusting mode after many the PG data.

• CONNECTION

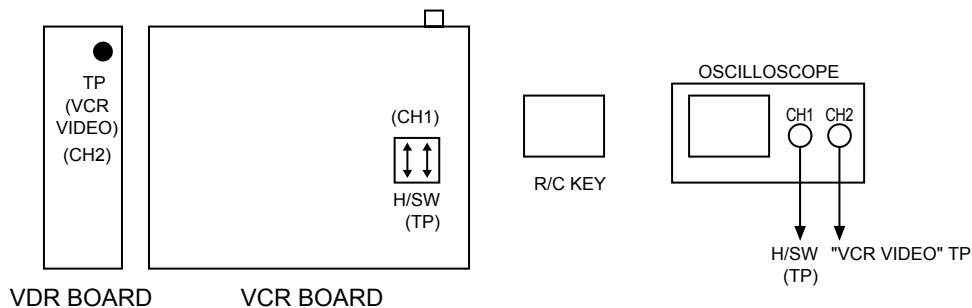

• WAVEFORM

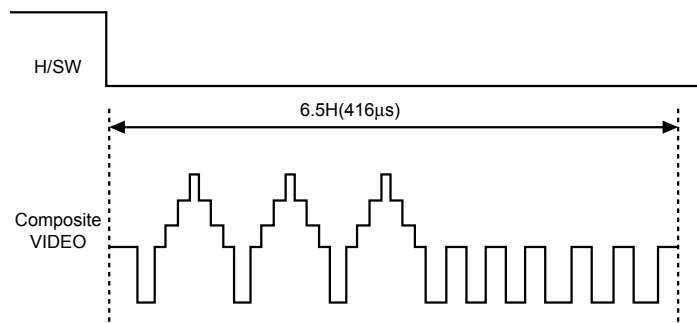

VCR ELECTRICAL TROUBLESHOOTING GUIDE

1. Power(SMPS) CIRCUIT

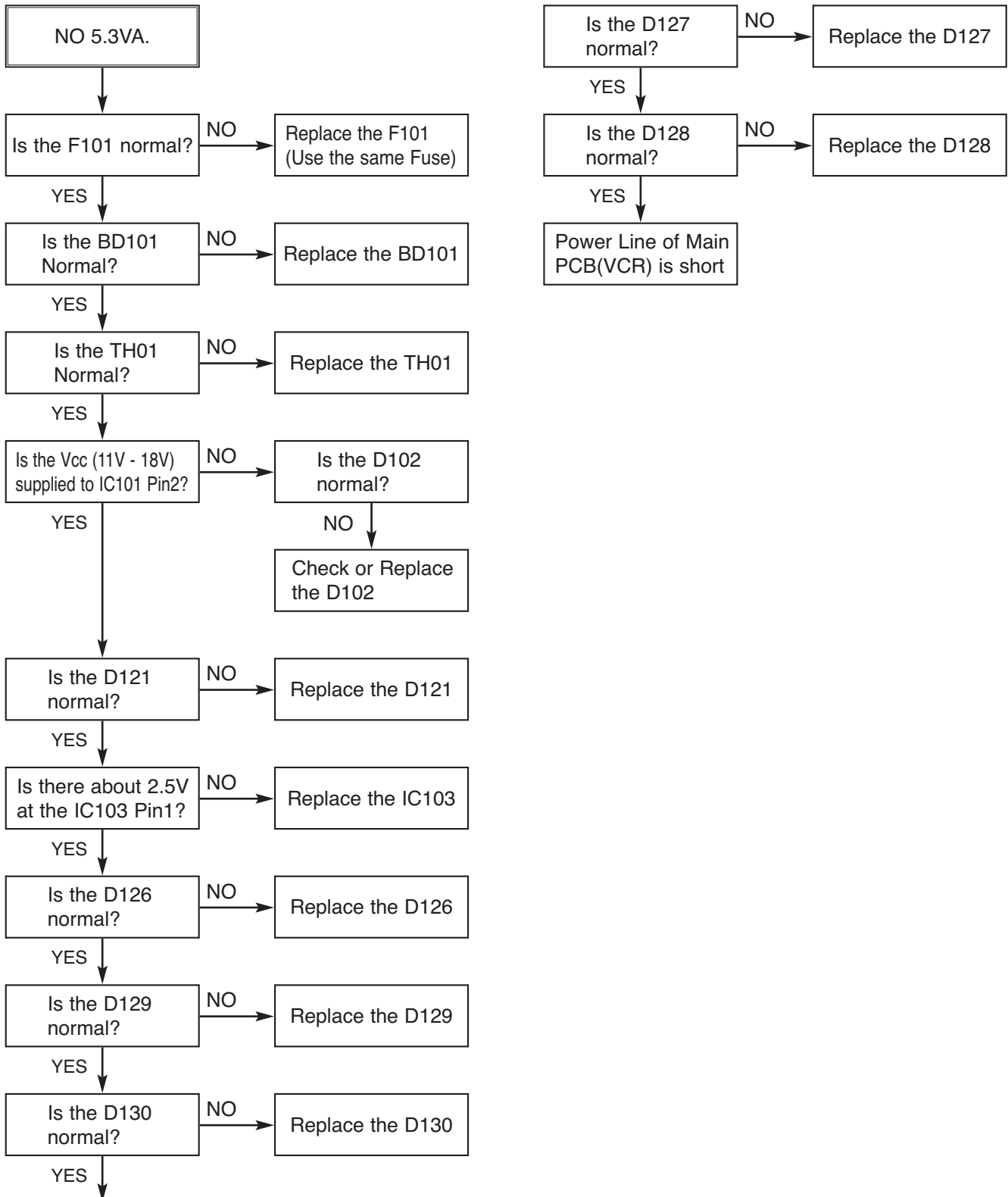

VCR ELECTRICAL TROUBLESHOOTING GUIDE

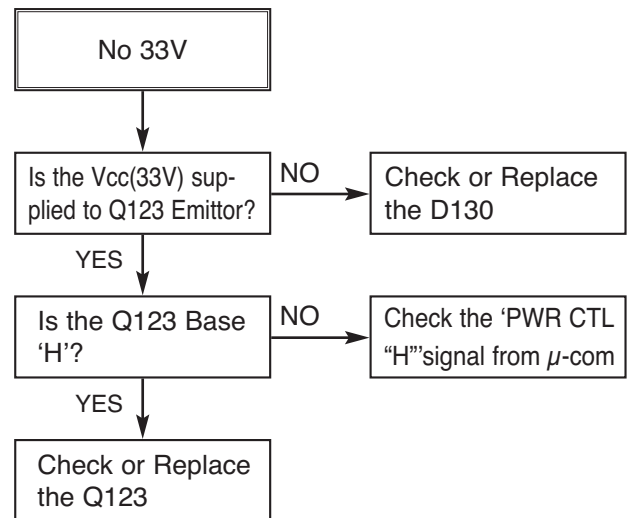
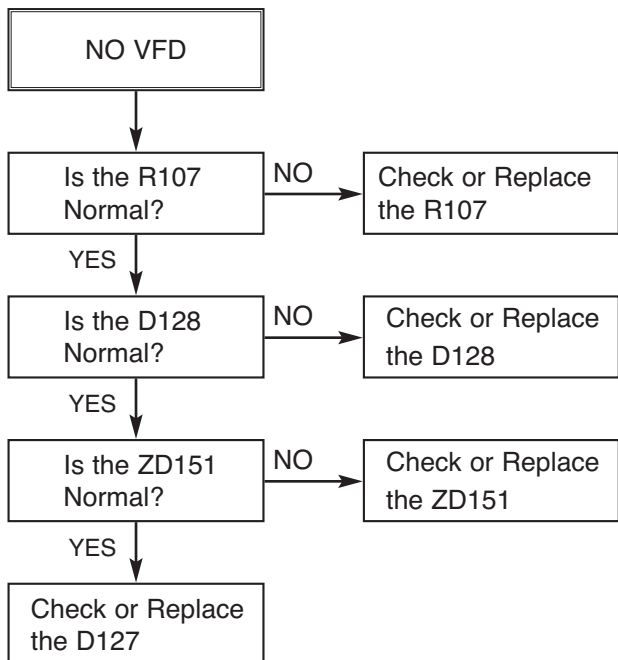
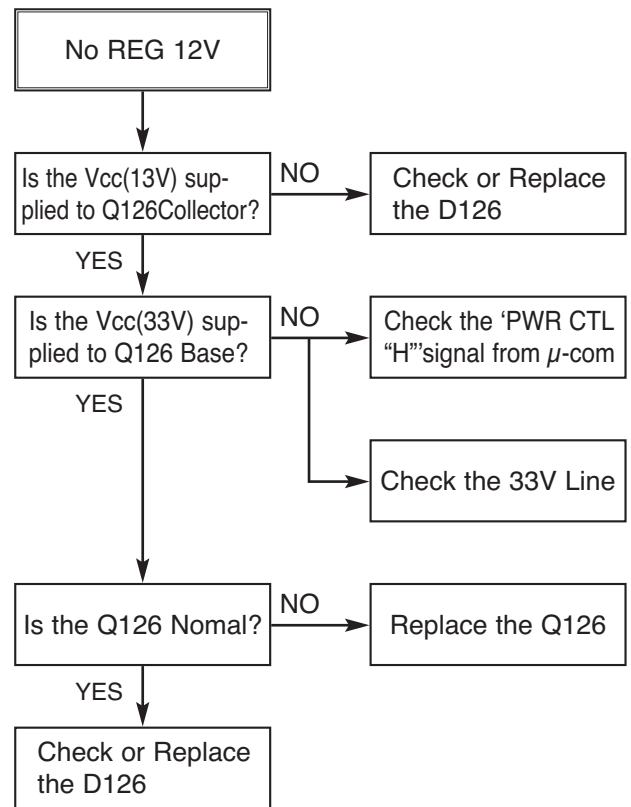
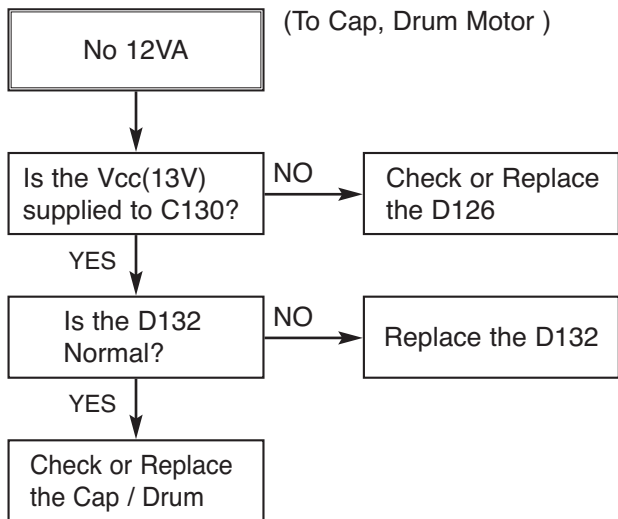

VCR ELECTRICAL TROUBLESHOOTING GUIDE

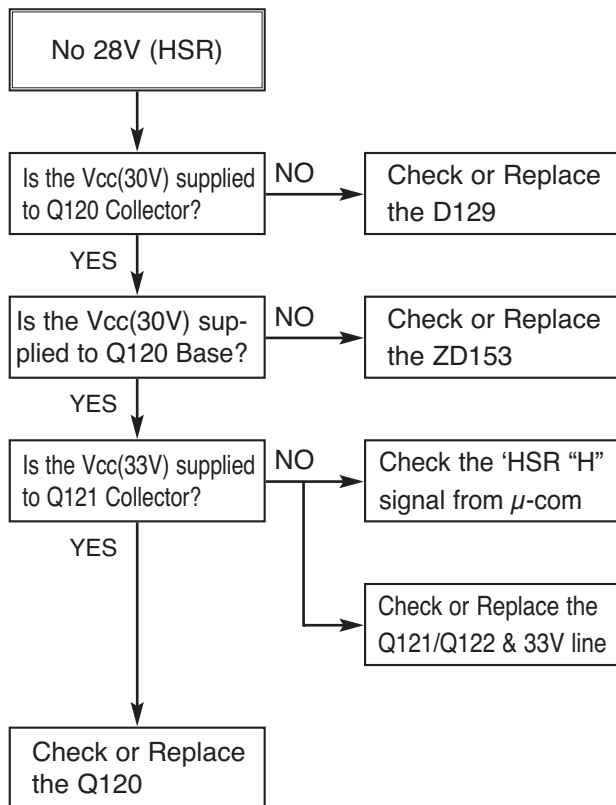

VCR ELECTRICAL TROUBLESHOOTING GUIDE

2. SYSTEM/KEY CIRCUIT

(1) AUTO STOP

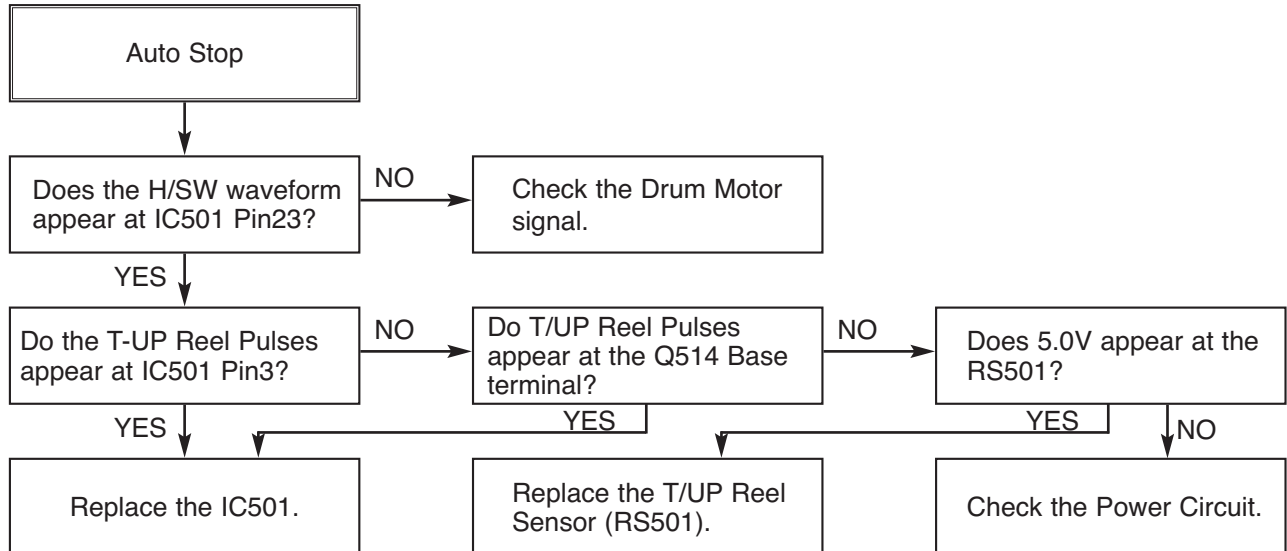

Note : Auto stop can occur because Grease or Oil has dried up

(2) The unstable loading of a Cassette tape

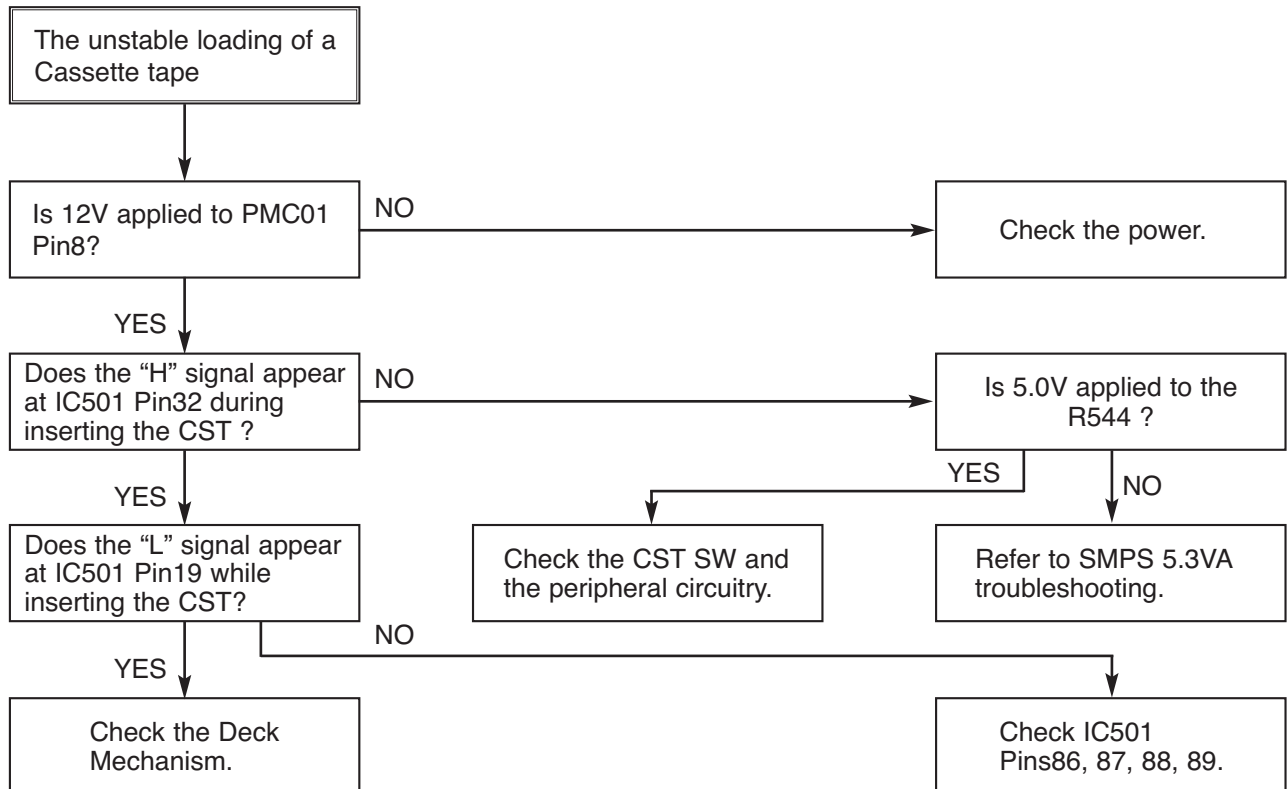

VCR ELECTRICAL TROUBLESHOOTING GUIDE

3. SERVO CIRCUIT

(1) Unstable Video in PB MODE

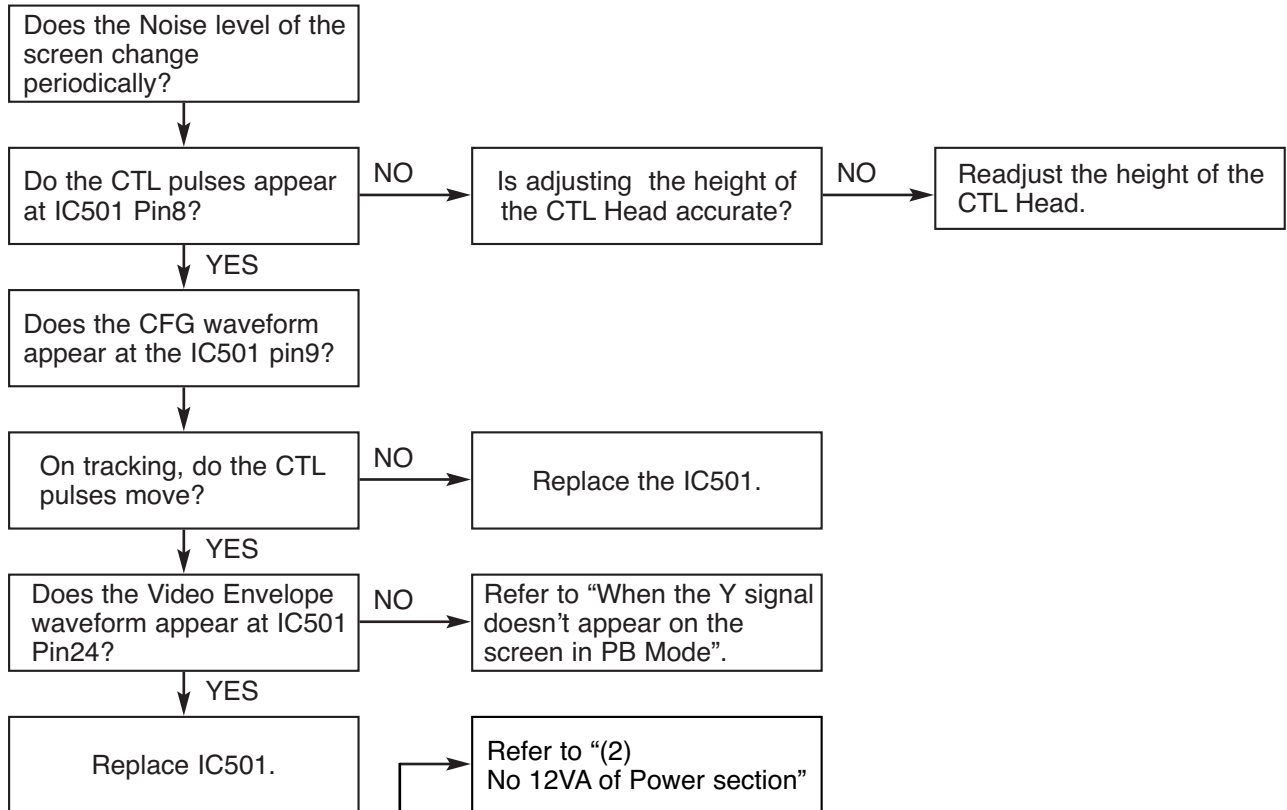

(2) When the Drum Motor doesn't run.

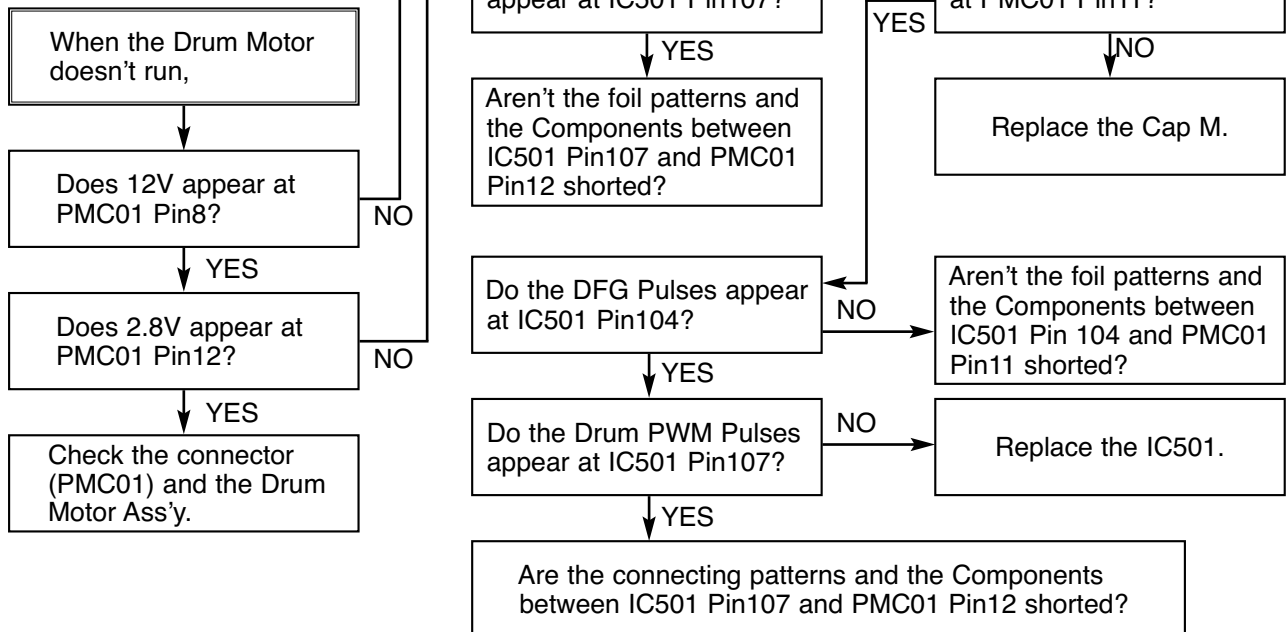

VCR ELECTRICAL TROUBLESHOOTING GUIDE

(3) When the Capstan Motor doesn't run,

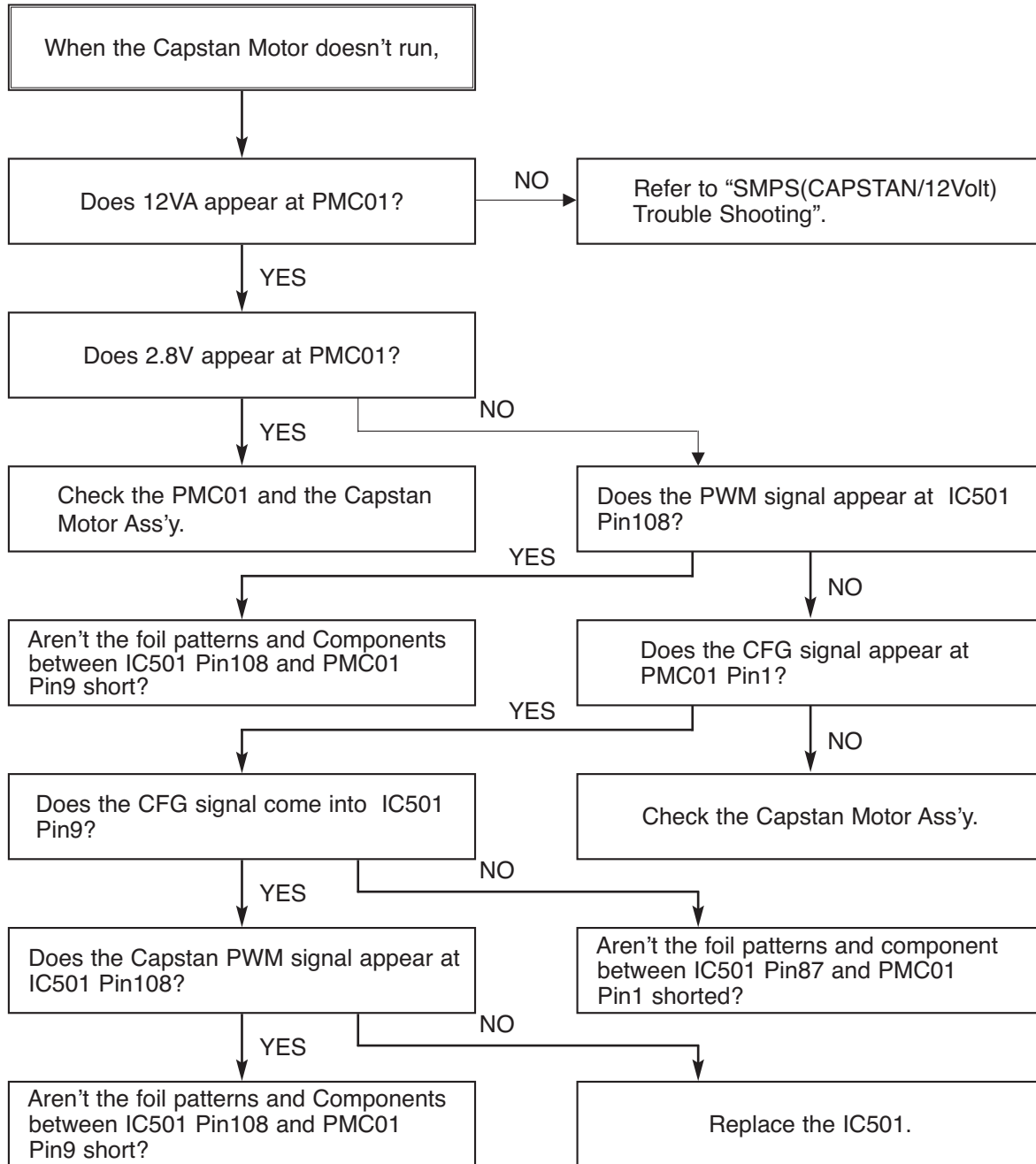

VCR ELECTRICAL TROUBLESHOOTING GUIDE

(4) Keys do not work

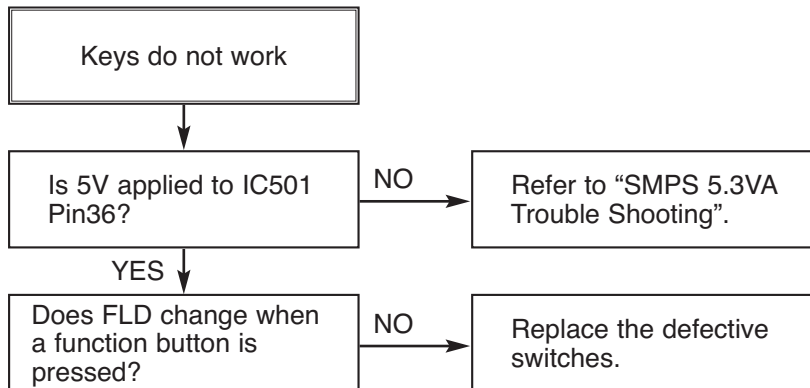

VCR ELECTRICAL TROUBLESHOOTING GUIDE

4. Y/C CIRCUIT

(1) No Video in EE Mode,

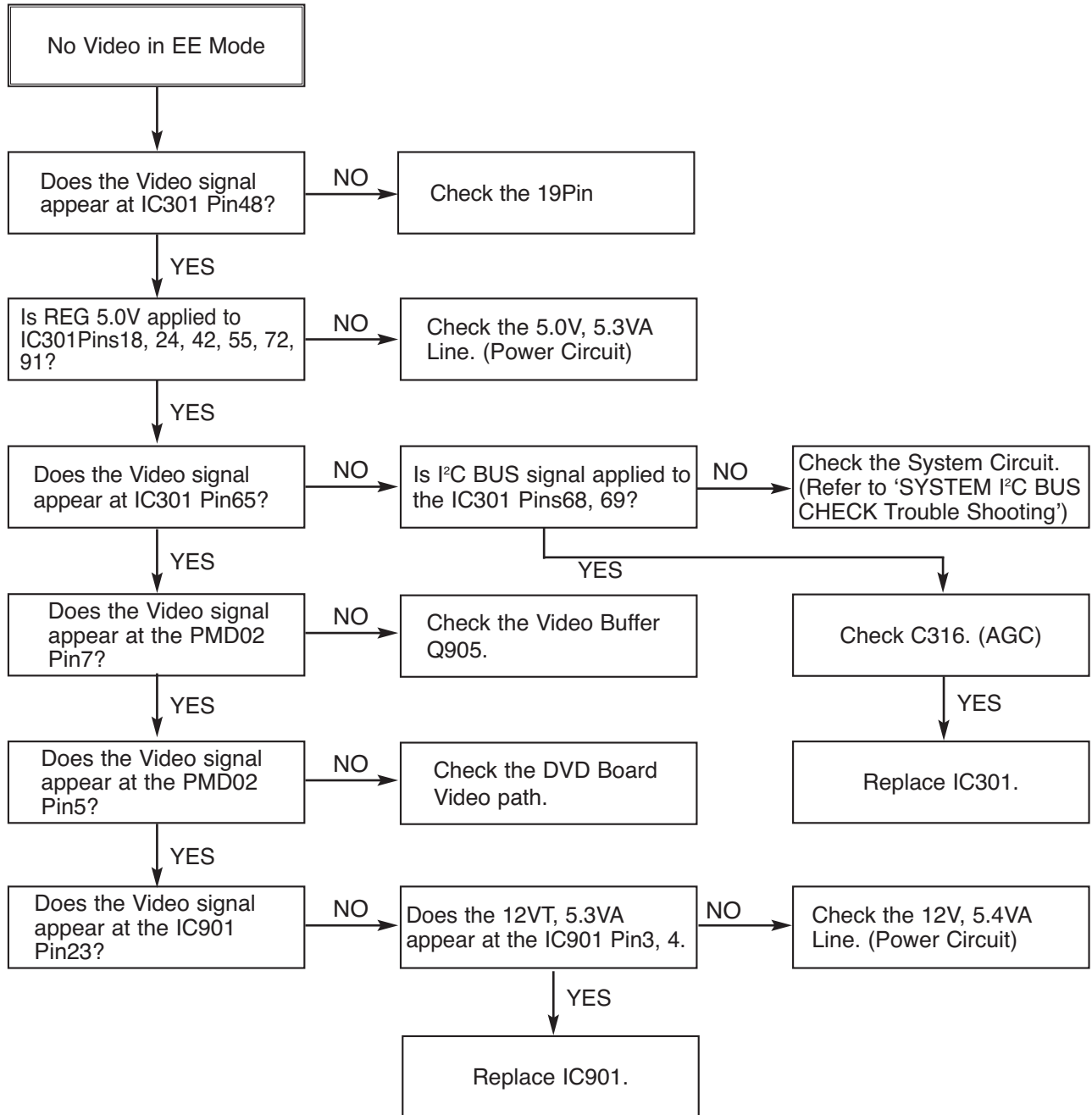

VCR ELECTRICAL TROUBLESHOOTING GUIDE

(2) When the Y(Luminance) signal doesn't appear on the screen in PB Mode,

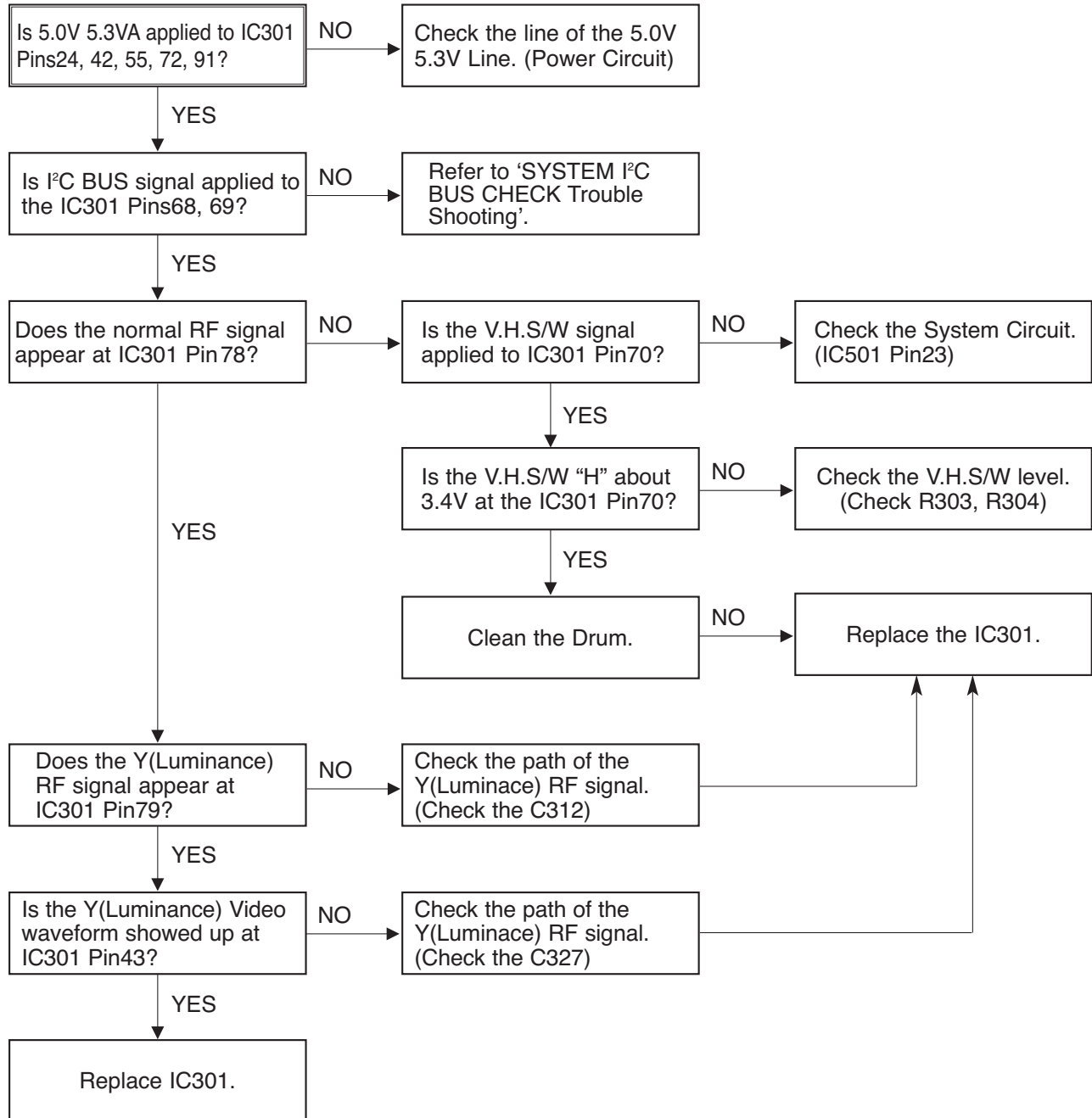

VCR ELECTRICAL TROUBLESHOOTING GUIDE

(3) When the C(Color) signal doesn't appear on the screen in PB Mode,

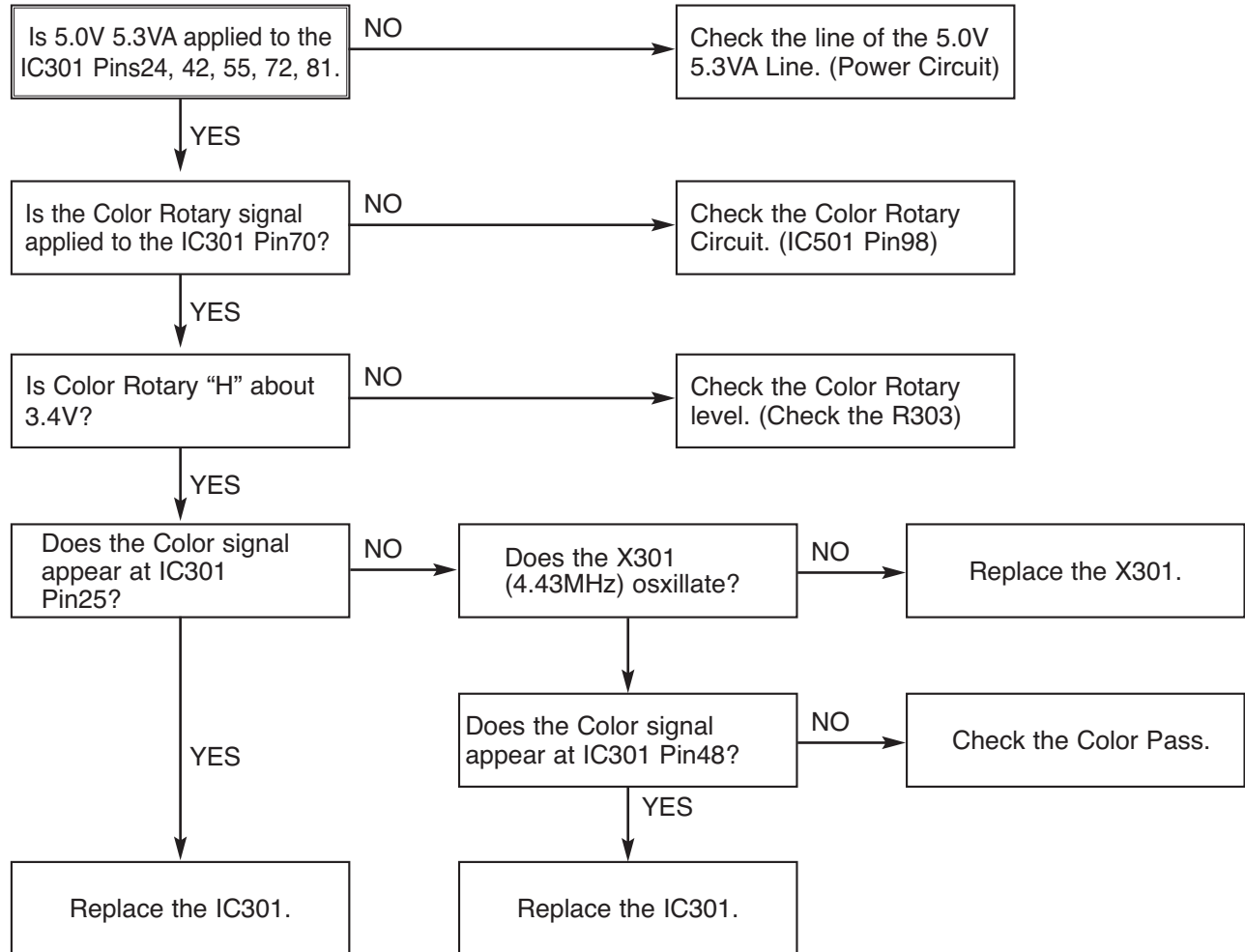

VCR ELECTRICAL TROUBLESHOOTING GUIDE

(4) When the Video signal doesn't appear on the screen in REC Mode,

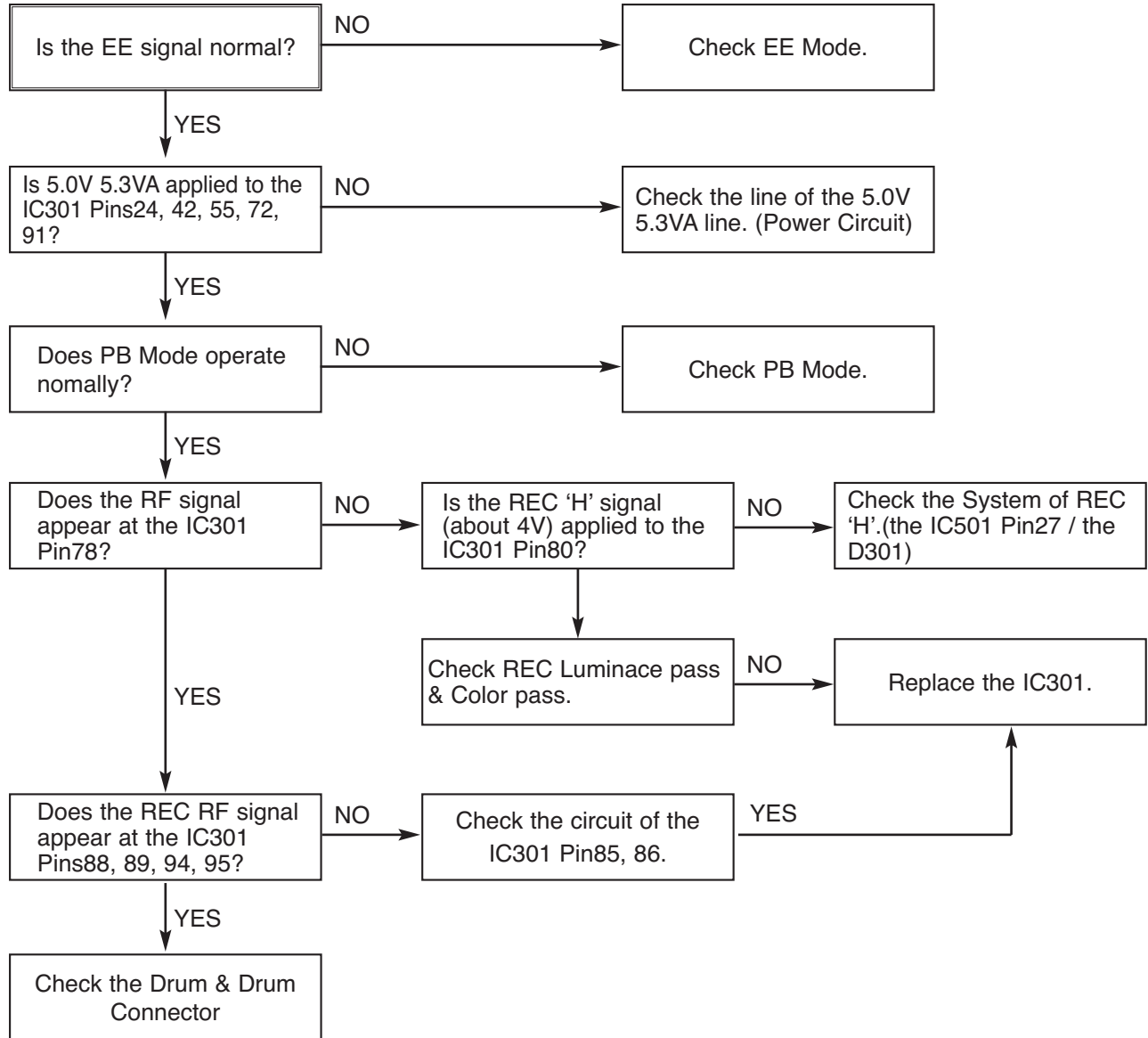

VCR ELECTRICAL TROUBLESHOOTING GUIDE

5. Hi-Fi CIRCUIT

(1) No Sound(EE Mode)

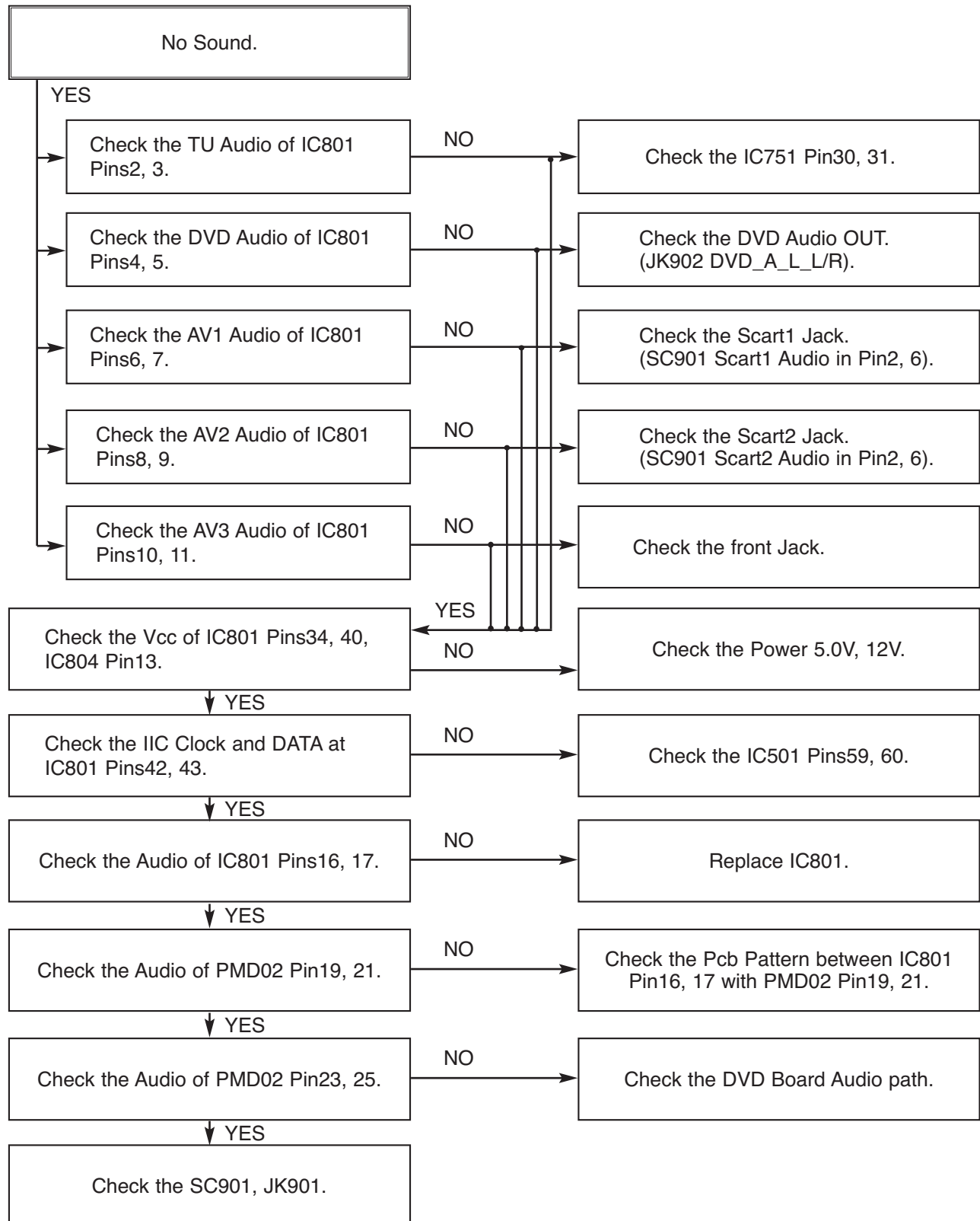

VCR ELECTRICAL TROUBLESHOOTING GUIDE

(2) Hi-Fi Playback

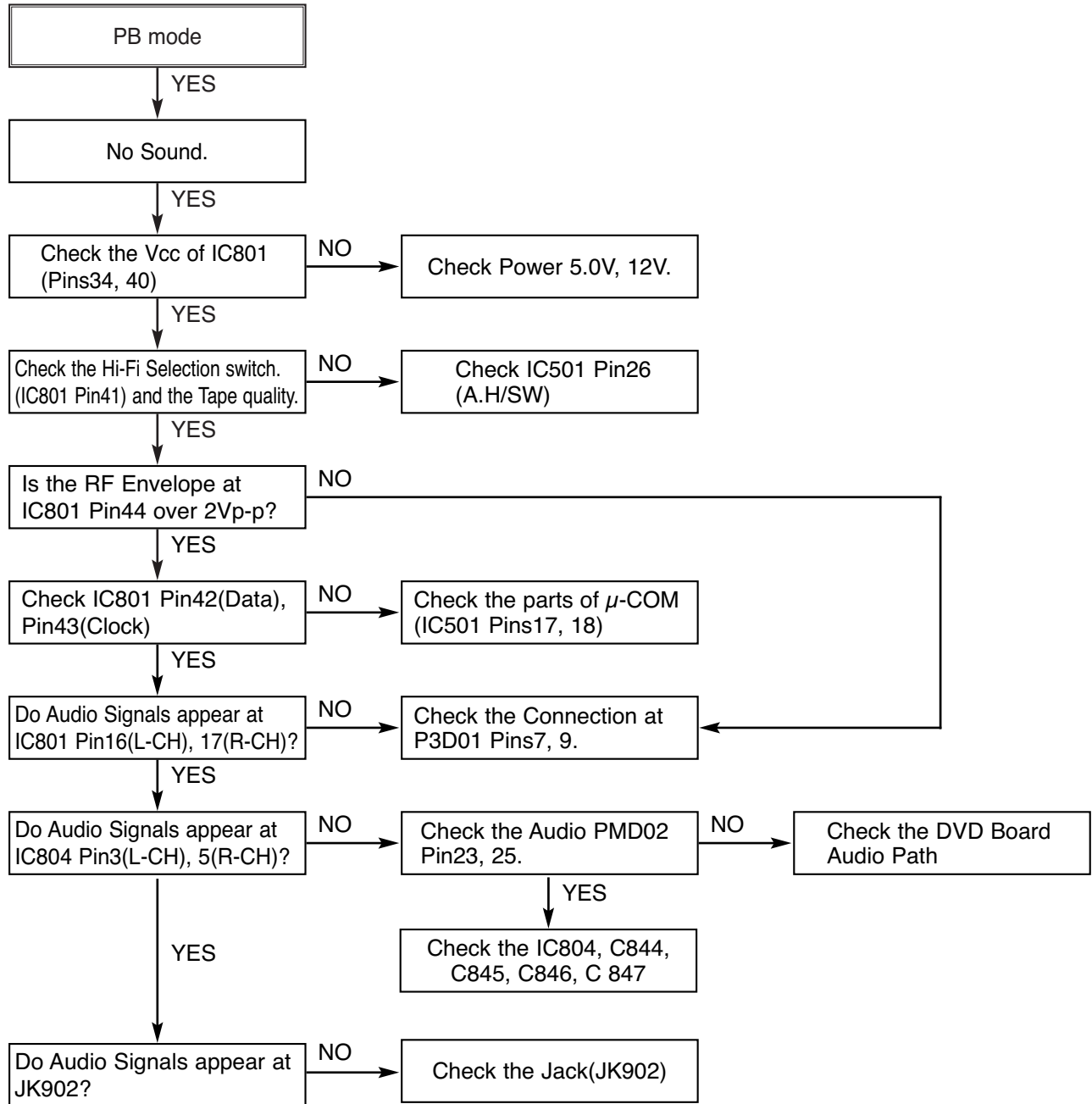

VCR ELECTRICAL TROUBLESHOOTING GUIDE

(3)

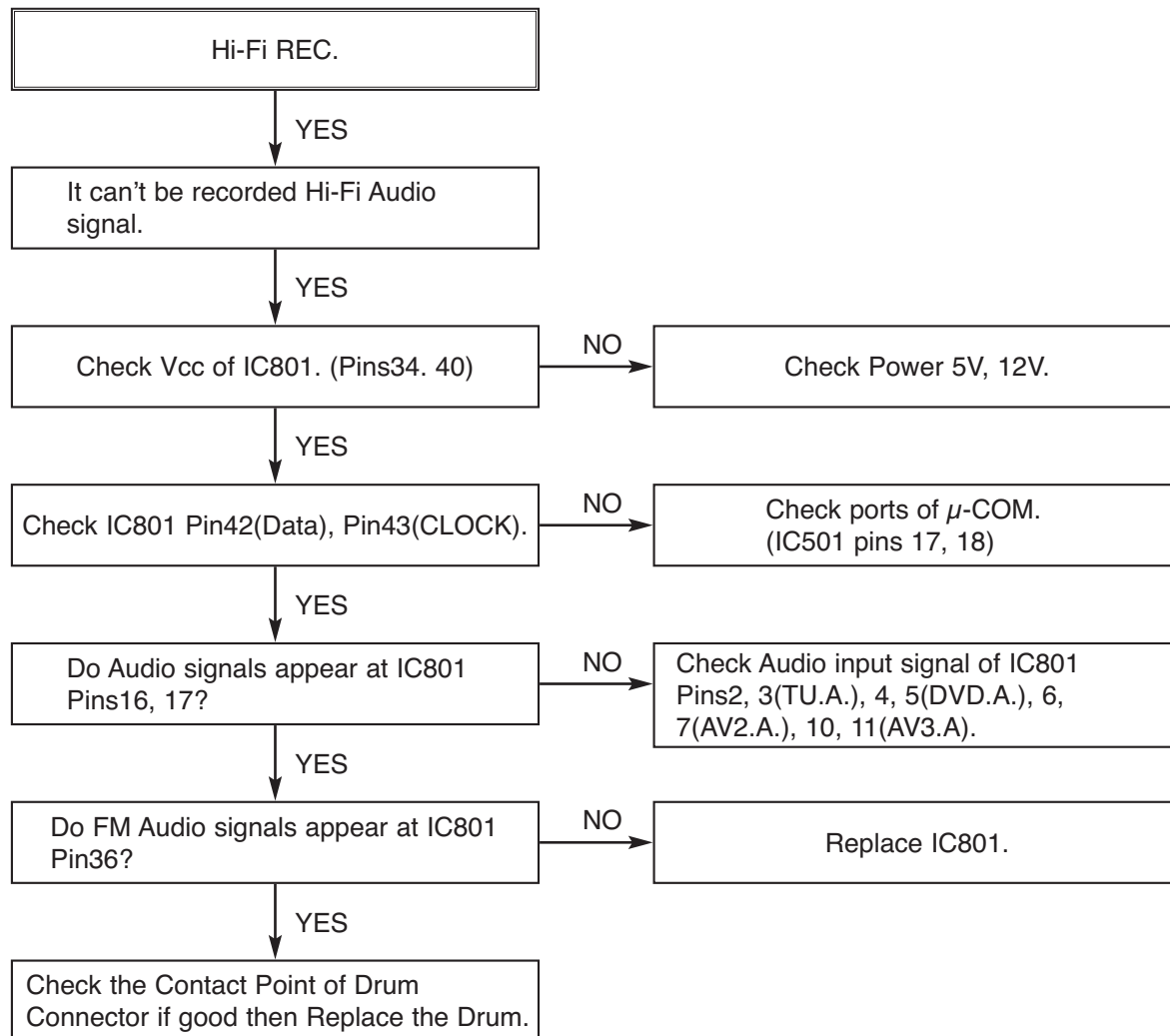

VCR ELECTRICAL TROUBLESHOOTING GUIDE

6. Tuner/IF CIRCUIT

(1) No Picture on the TV screen

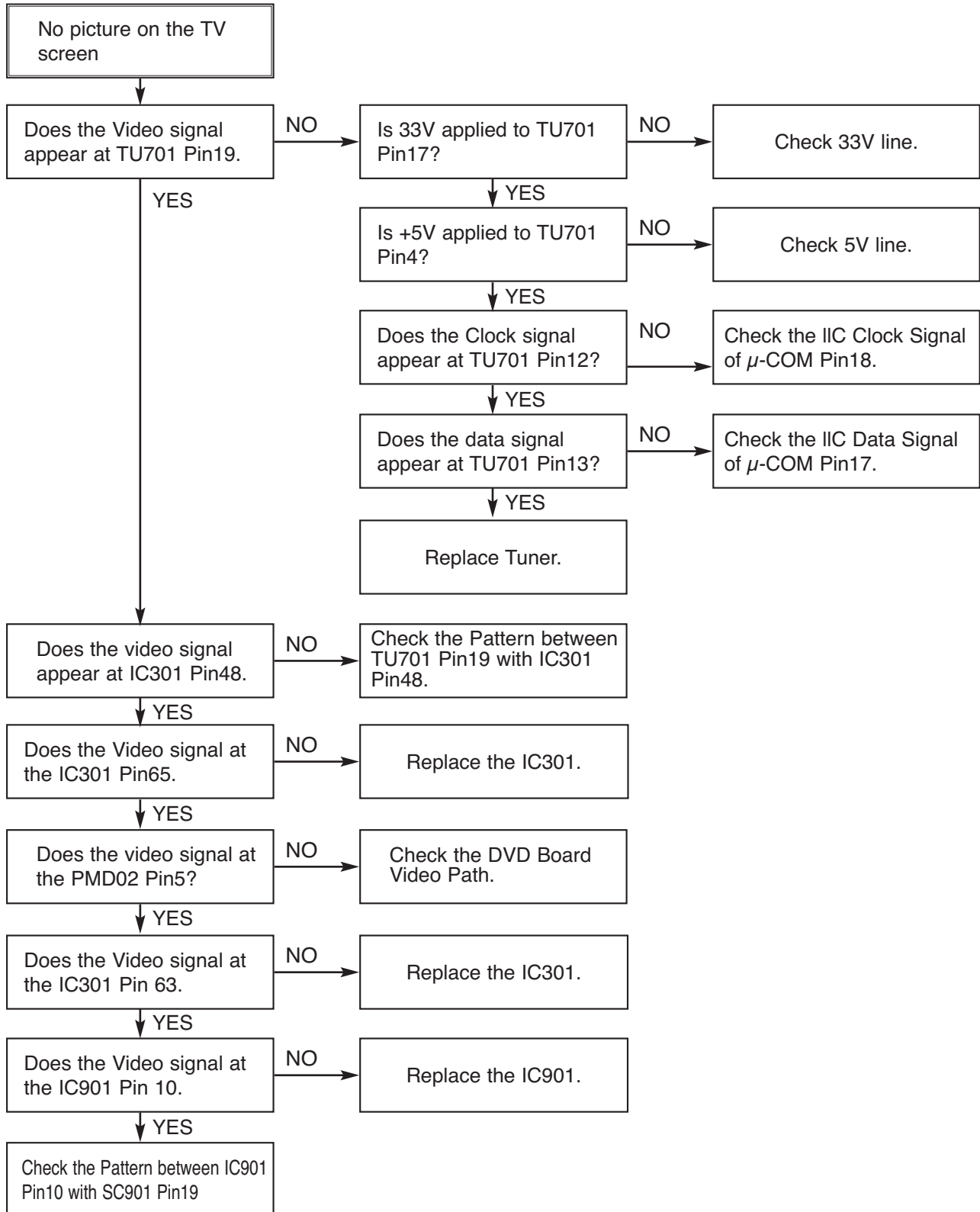

VCR ELECTRICAL TROUBLESHOOTING GUIDE

(B) No Sound

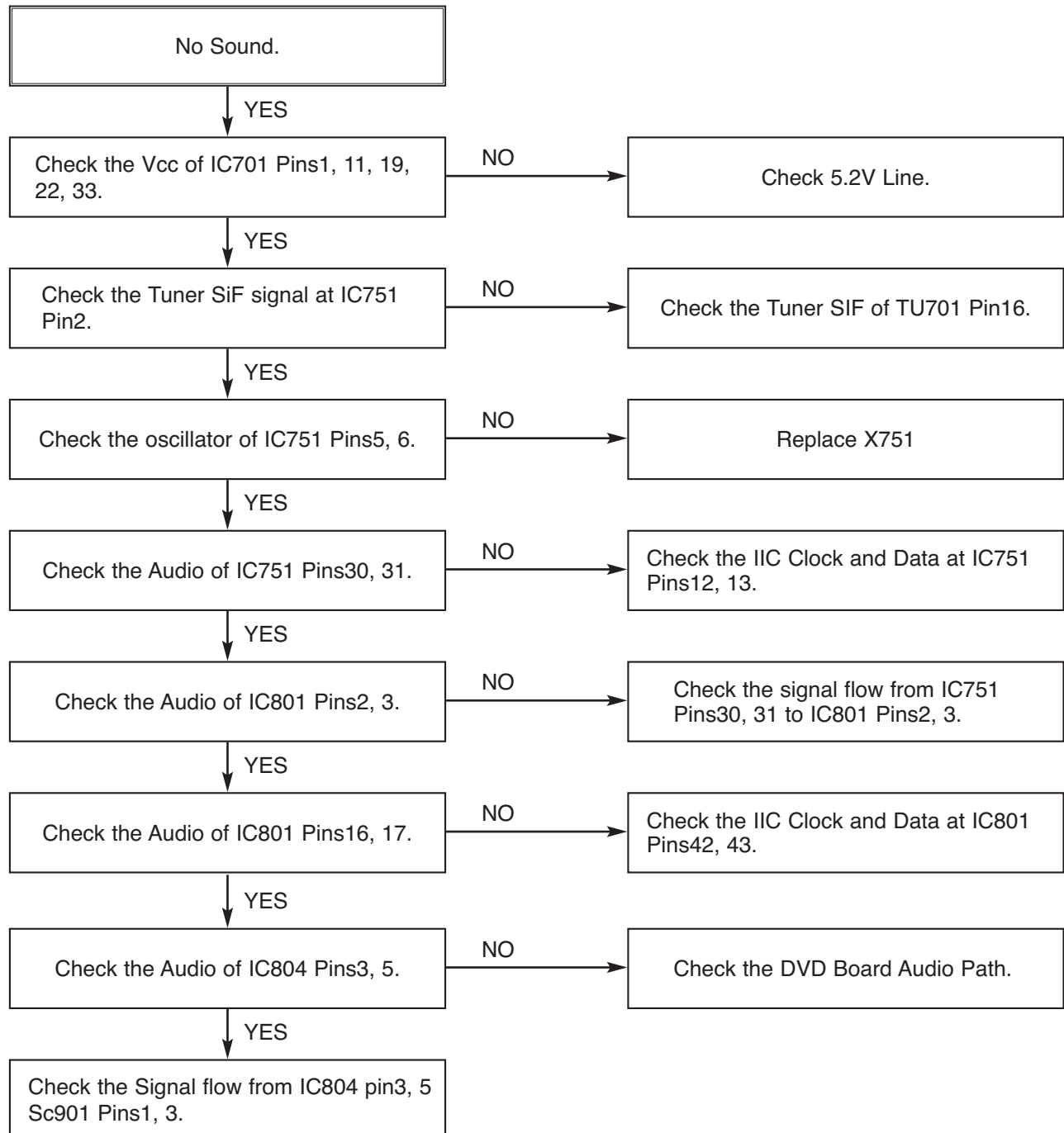

BLOCK DIAGRAMS

1. POWER(SMPS) BLOCK DIAGRAM

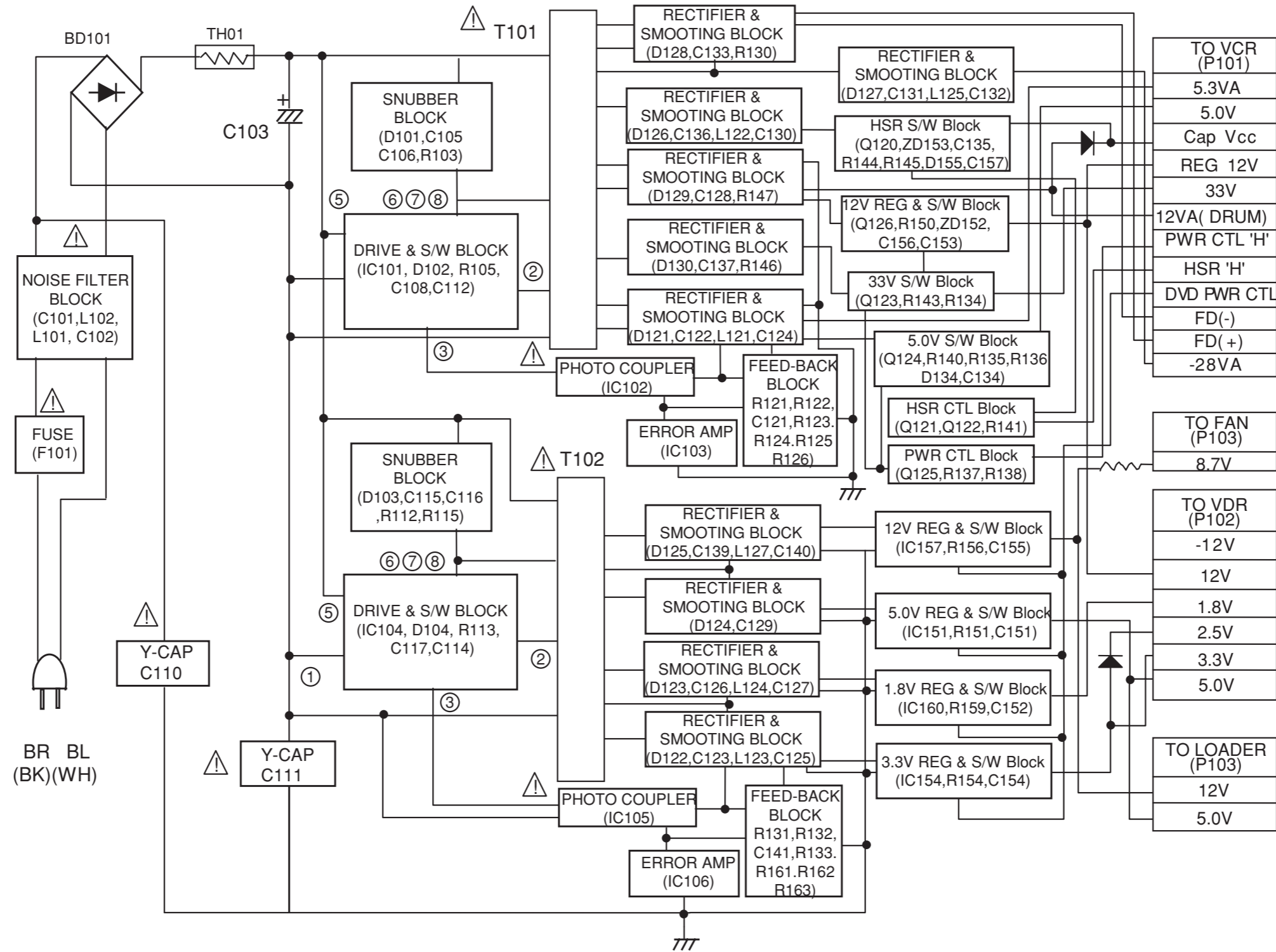

VCR+DVD REC SCART+RCA

2. TUNER/IF, NICAM & A2 BLOCK DIAGRAM

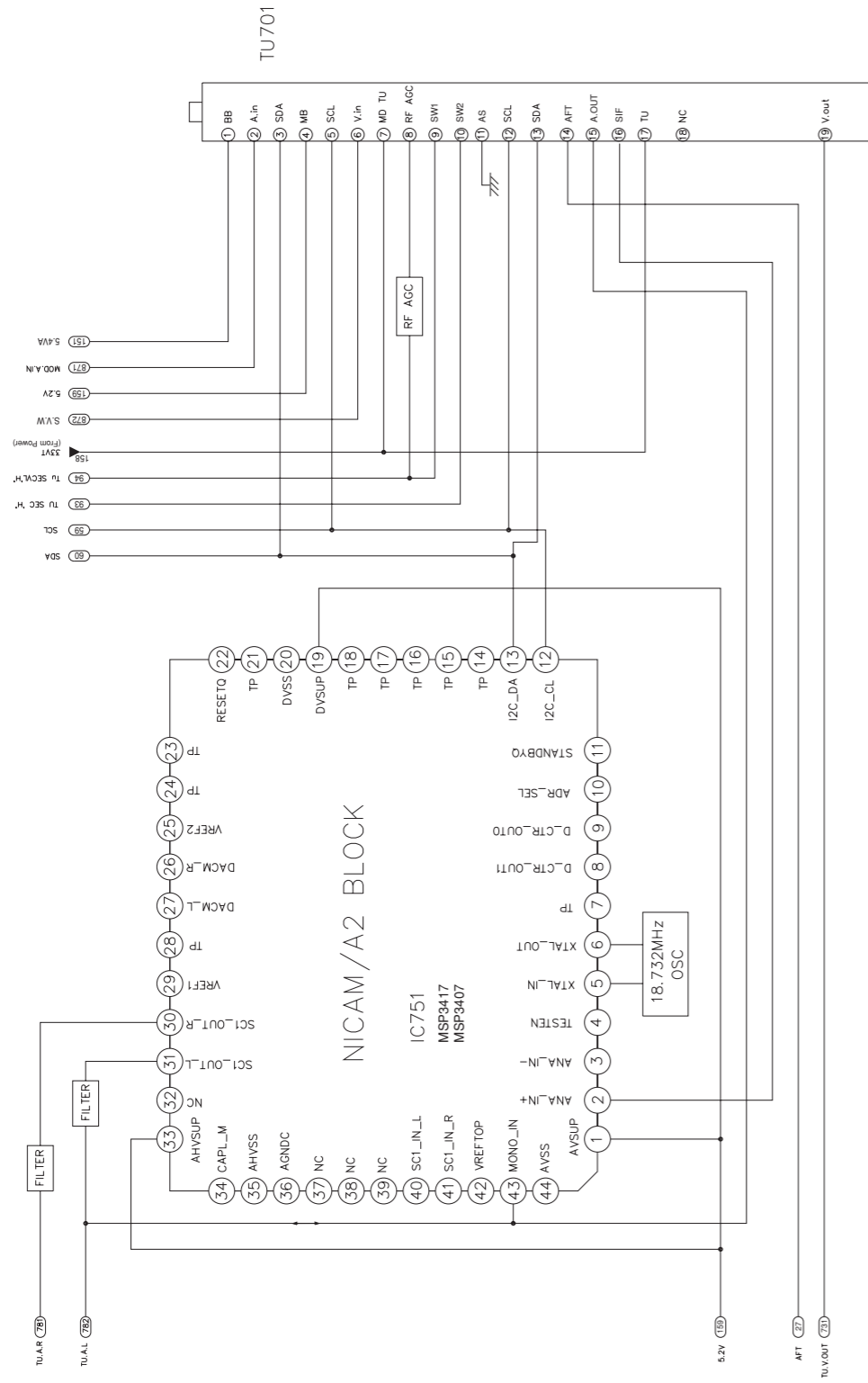

3. VPS BLOCK DIAGRAM

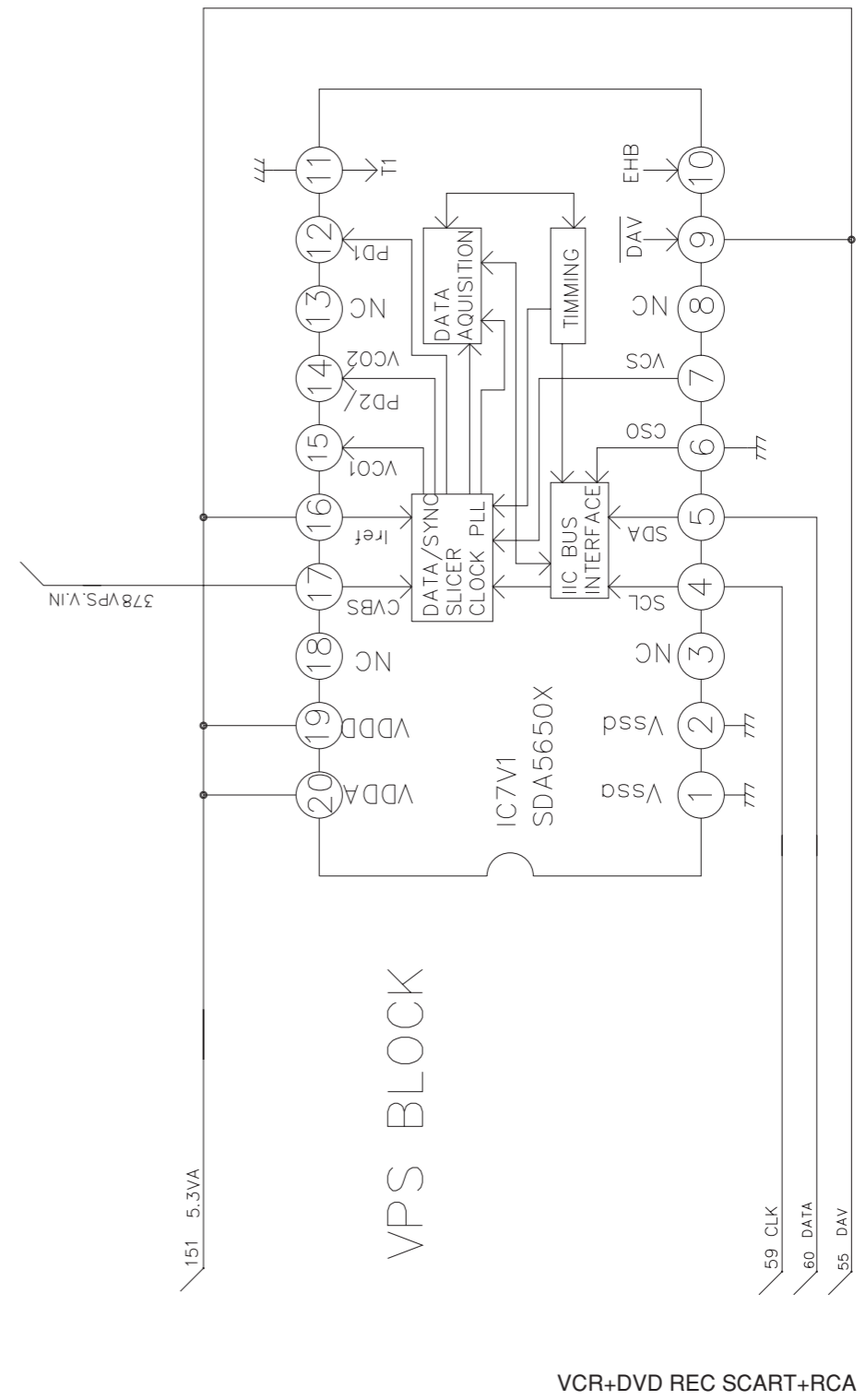

4. Y/C BLOCK DIAGRAM

(PB Mode)

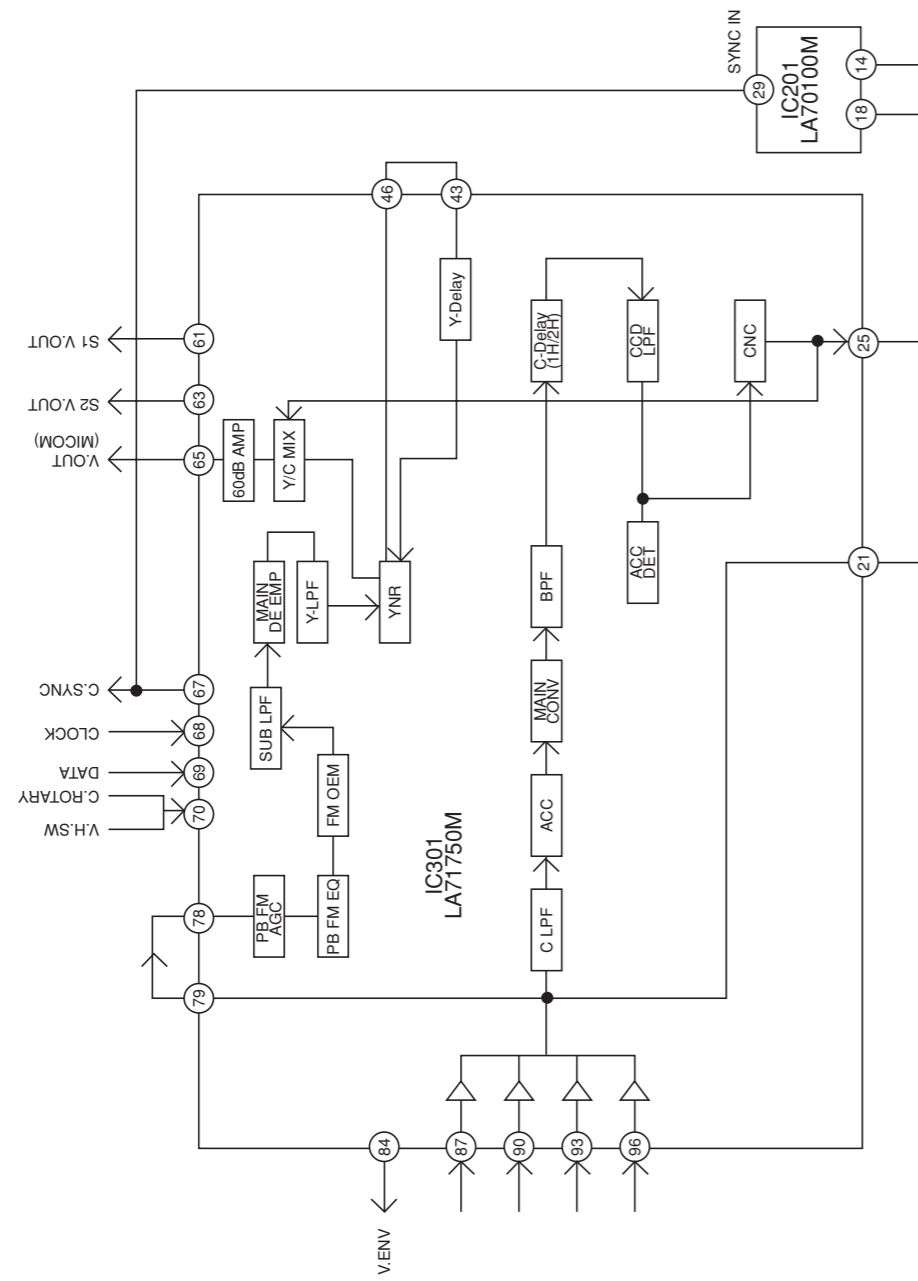

(REC Mode)

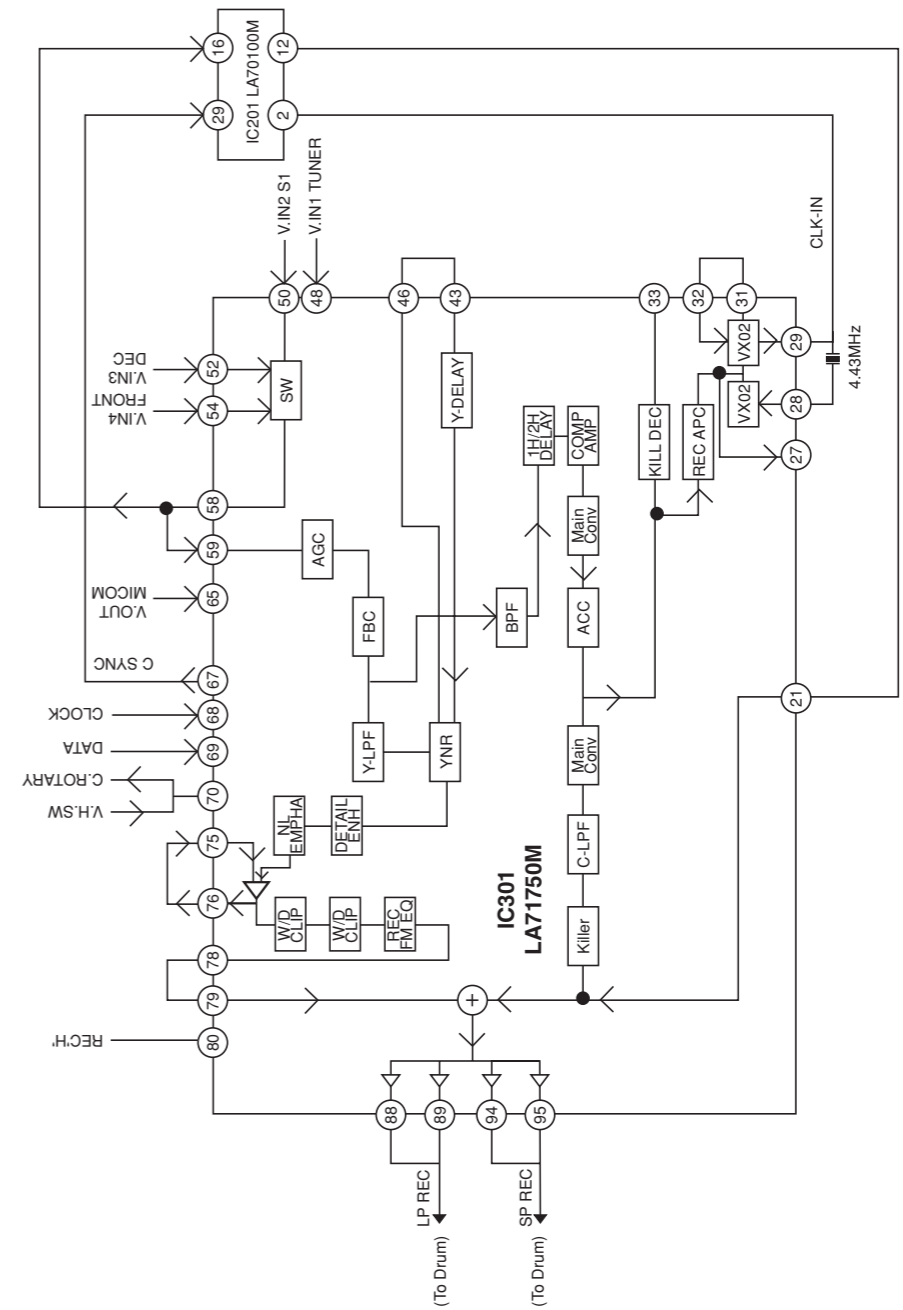

VCR+DVD REC SCART+RCA

5. NORMAL AUDIO BLOCK DIAGRAM

(EE Mode)

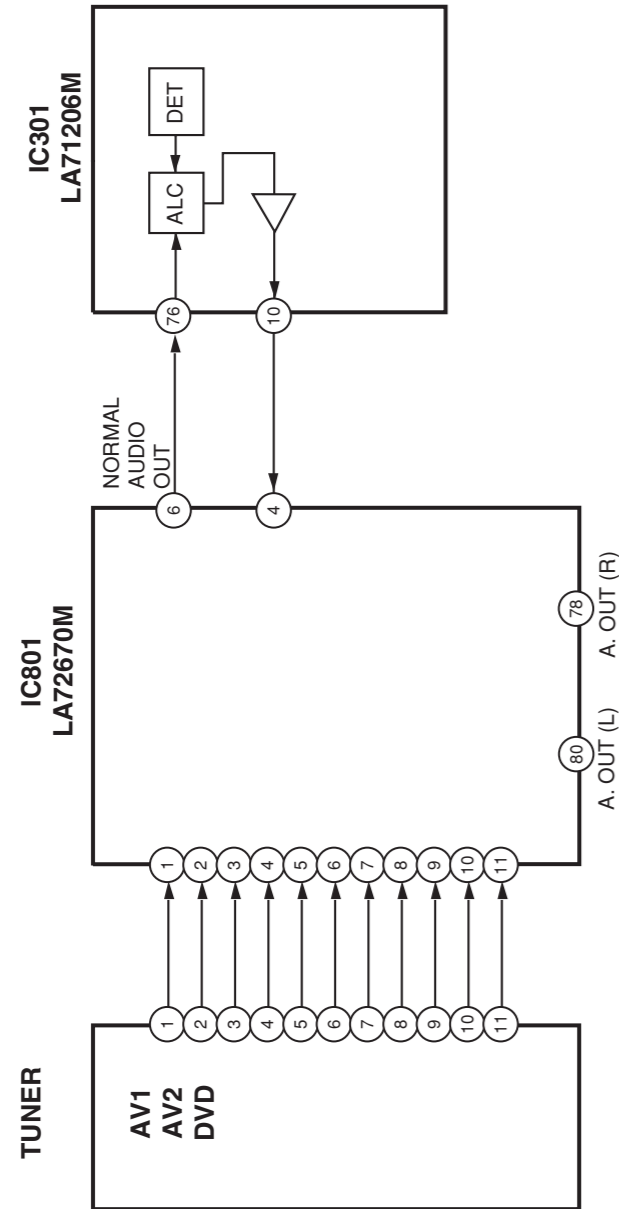

(PB Mode)

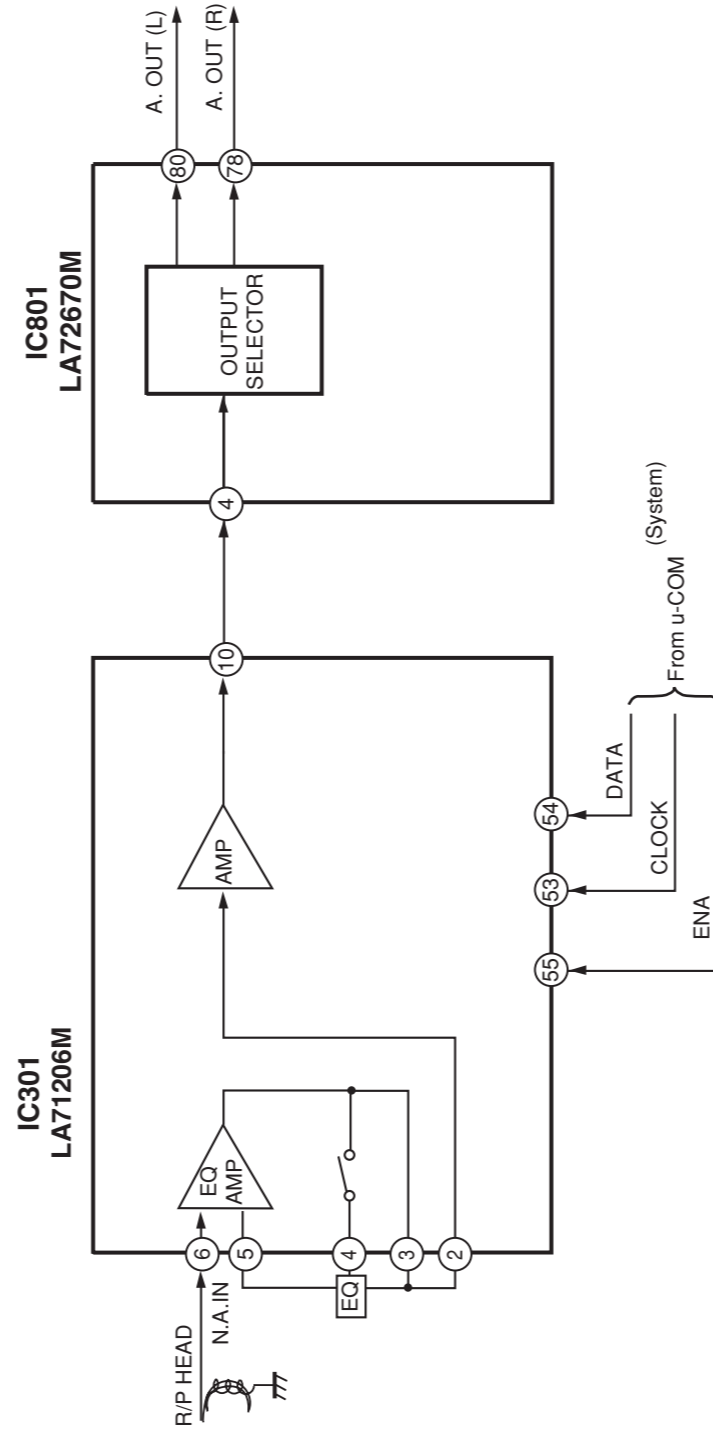

(REC Mode)

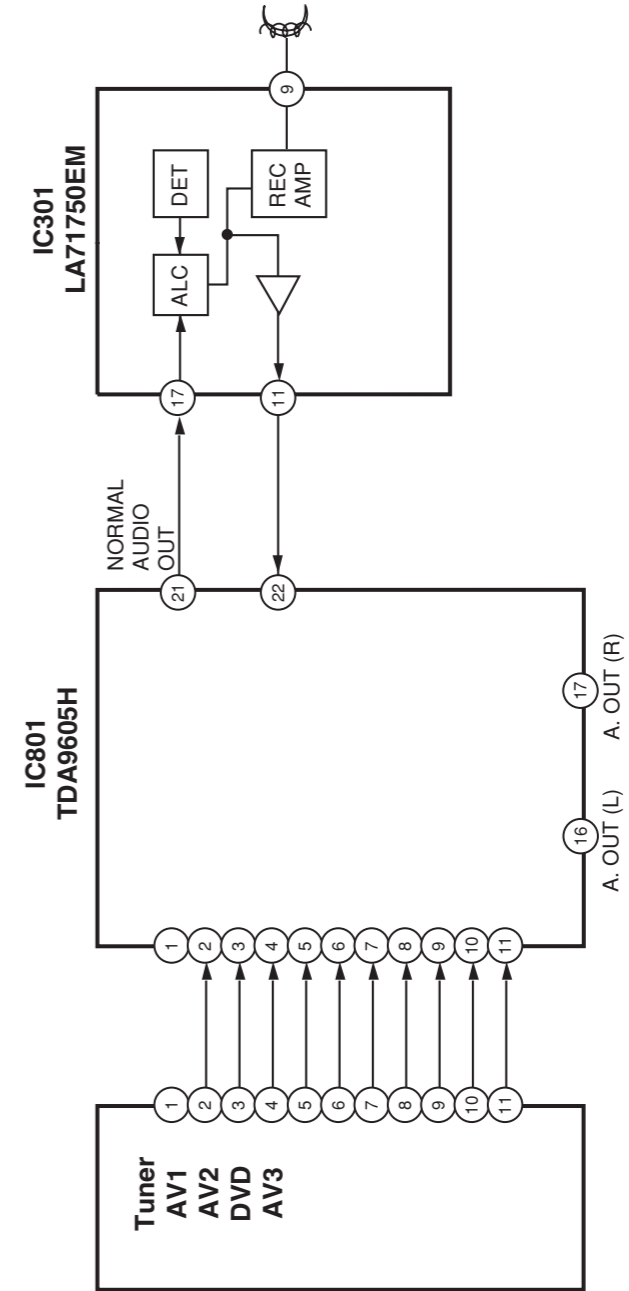

VCR+DVD REC SCART+RCA

6. Hi-Fi BLOCK DIAGRAM

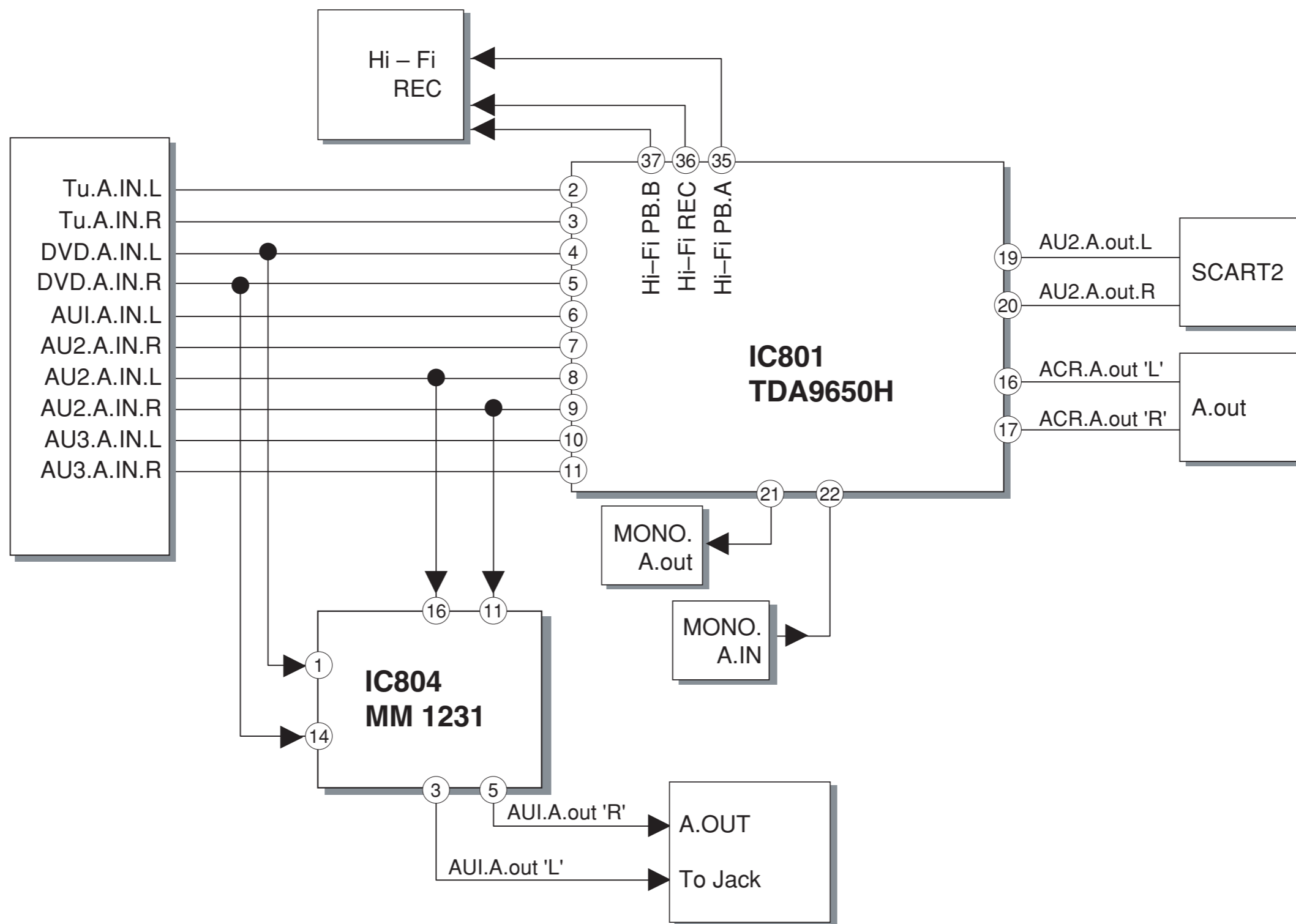

VCR+DVD REC SCART+RCA

7. SYSTEM BLOCK DIAGRAM

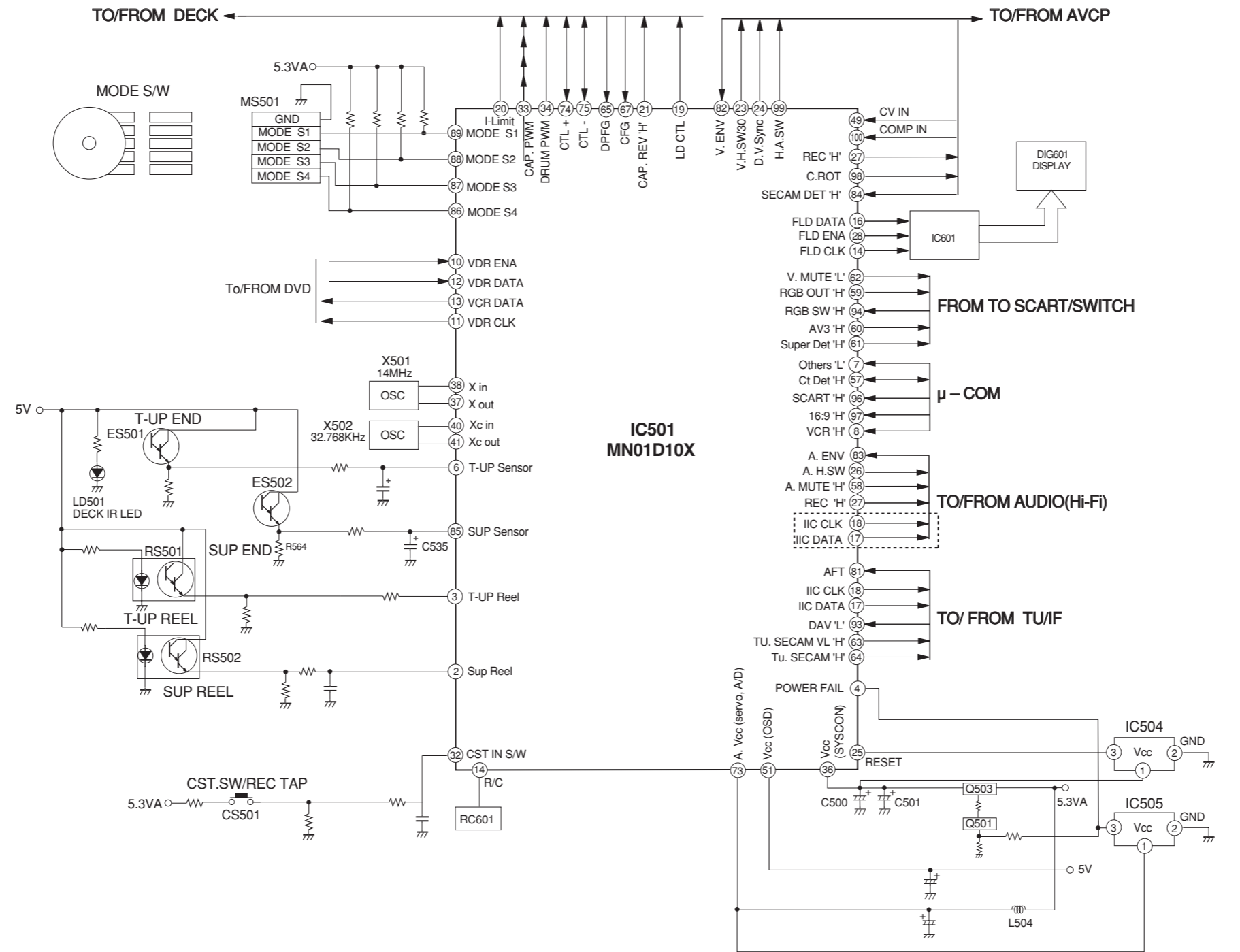

VCR+DVD REC SCART+RCA

8. SCART & SWITCH BLOCK DIAGRAM

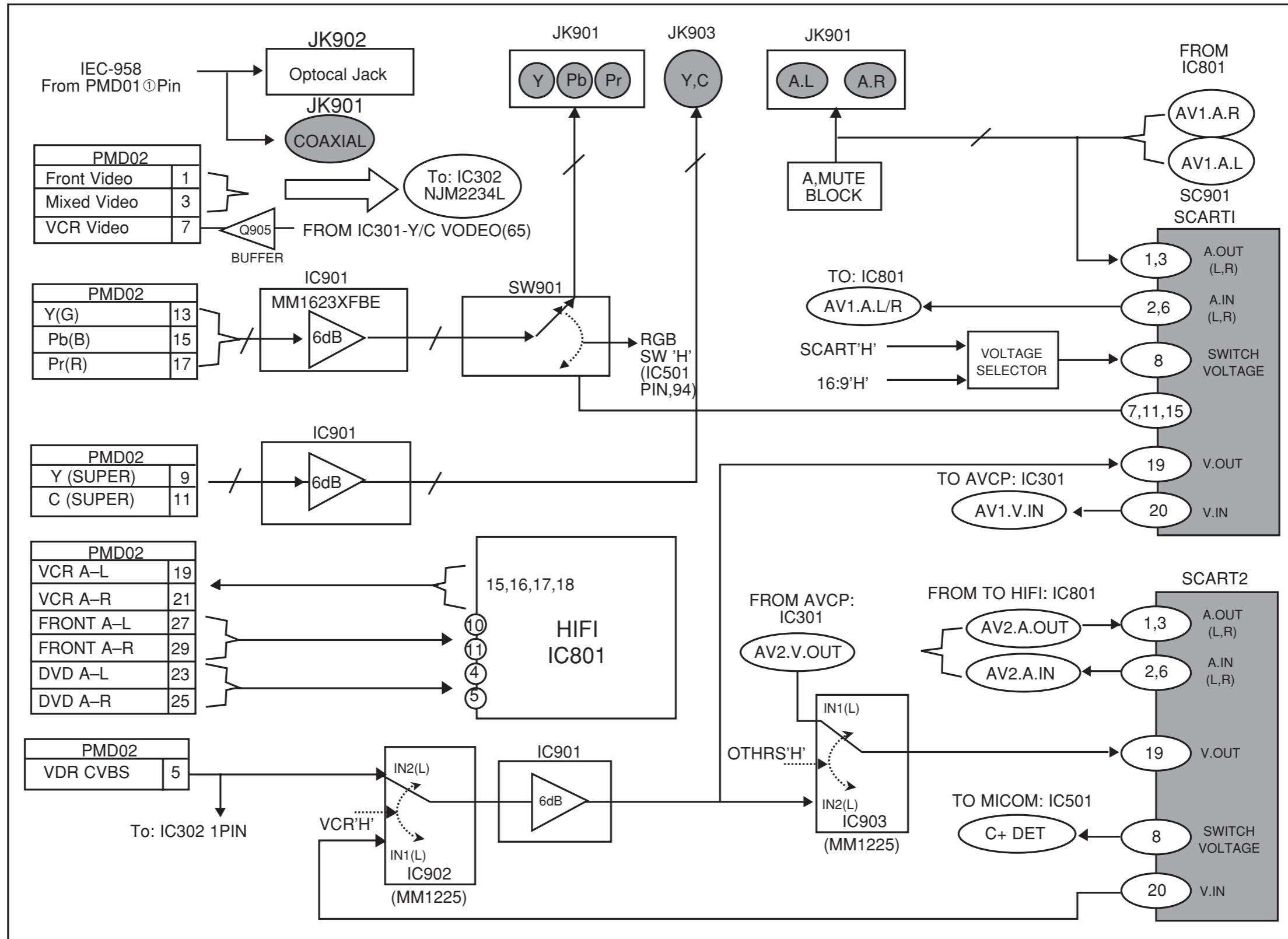

VCR+DVD REC SCART

CIRCUIT DIAGRAMS

1. POWER(SMPS) CIRCUIT DIAGRAM

IMPORTANT SAFETY NOTICE

WHEN SERVICING THIS CHASSIS, UNDER NO CIRCUMSTANCES SHOULD THE ORIGINAL DESIGN BE MODIFIED OR ALTERED WITHOUT PERMISSION FROM THE PHILIPS ELECTRONICS CORPORATION. ALL COMPONENTS SHOULD BE REPLACED ONLY WITH TYPES IDENTICAL TO THOSE IN THE ORIGINAL CIRCUIT. SPECIAL COMPONENTS ARE SHADED ON THE SCHEMATIC FOR EASY IDENTIFICATION. THIS CIRCUIT DIAGRAM MAY OCCASIONALLY DIFFER FROM THE ACTUAL CIRCUIT USED. THIS WAY, IMPLEMENTATION OF THE LATEST SAFETY AND PERFORMANCE IMPROVEMENT CHANGES INTO THE SET IS NOT DELAYED UNTIL THE NEW SERVICE LITERATURE IS PRINTED.

NOTE :

1. Shaded(■) parts are critical for safety. Replace only with specified part number.
2. Voltages are DC-measured with a digital voltmeter during Play mode.

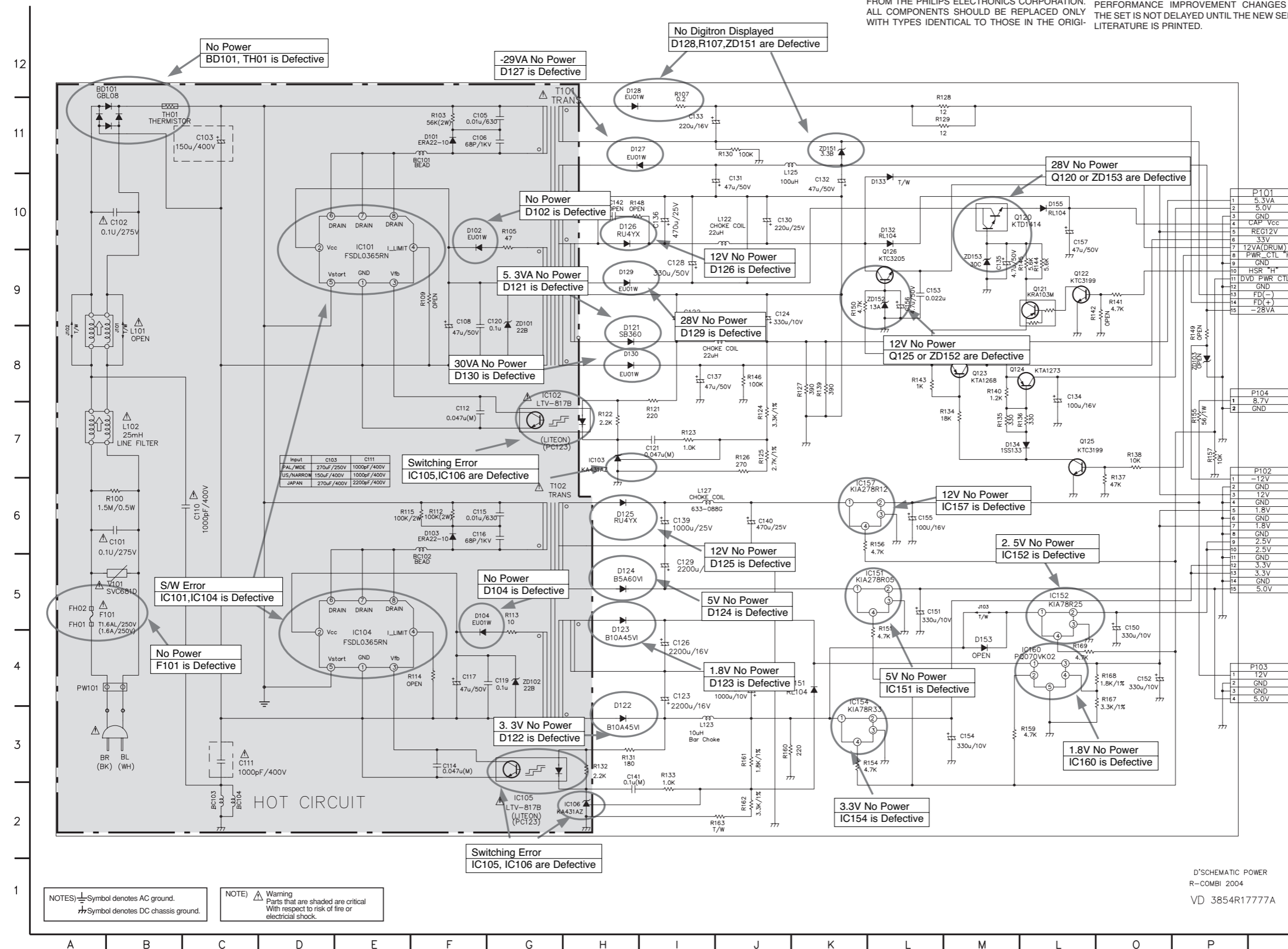

NOTES) Symbol denotes AC ground.
 Symbol denotes DC chassis ground.

NOTE) Warning
Parts that are shaded are critical
With respect to risk of fire or
electrical shock.

D'SCHEMATIC POWER
R-COMBI 2004
VD 3854R17777A

2. TUNER CIRCUIT DIAGRAM

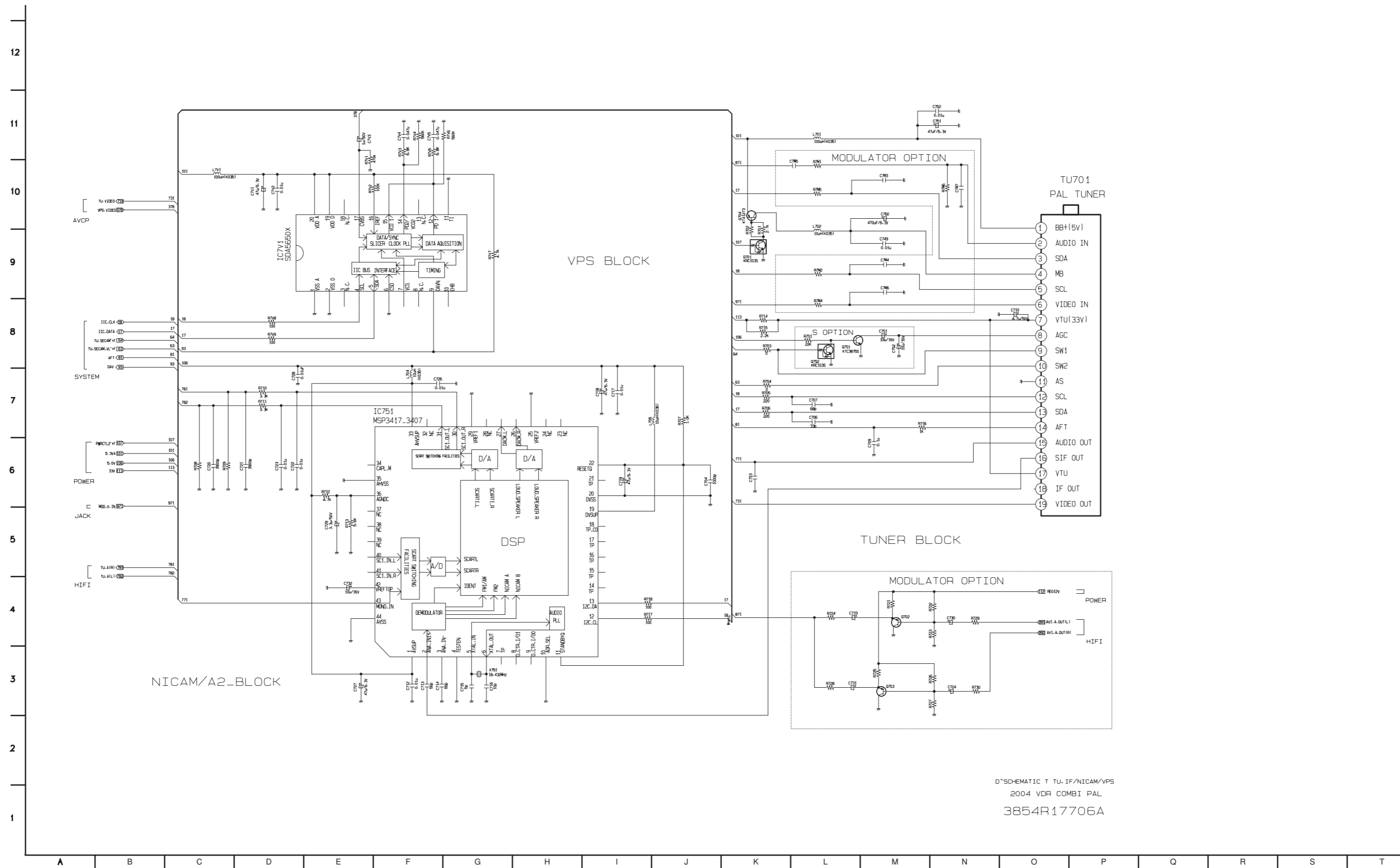

D SCHEMATIC T TU. IF/NICAM/VPS
 2004 VDR COMBI PAL
 3854R17706A

3. A/V CIRCUIT DIAGRAM

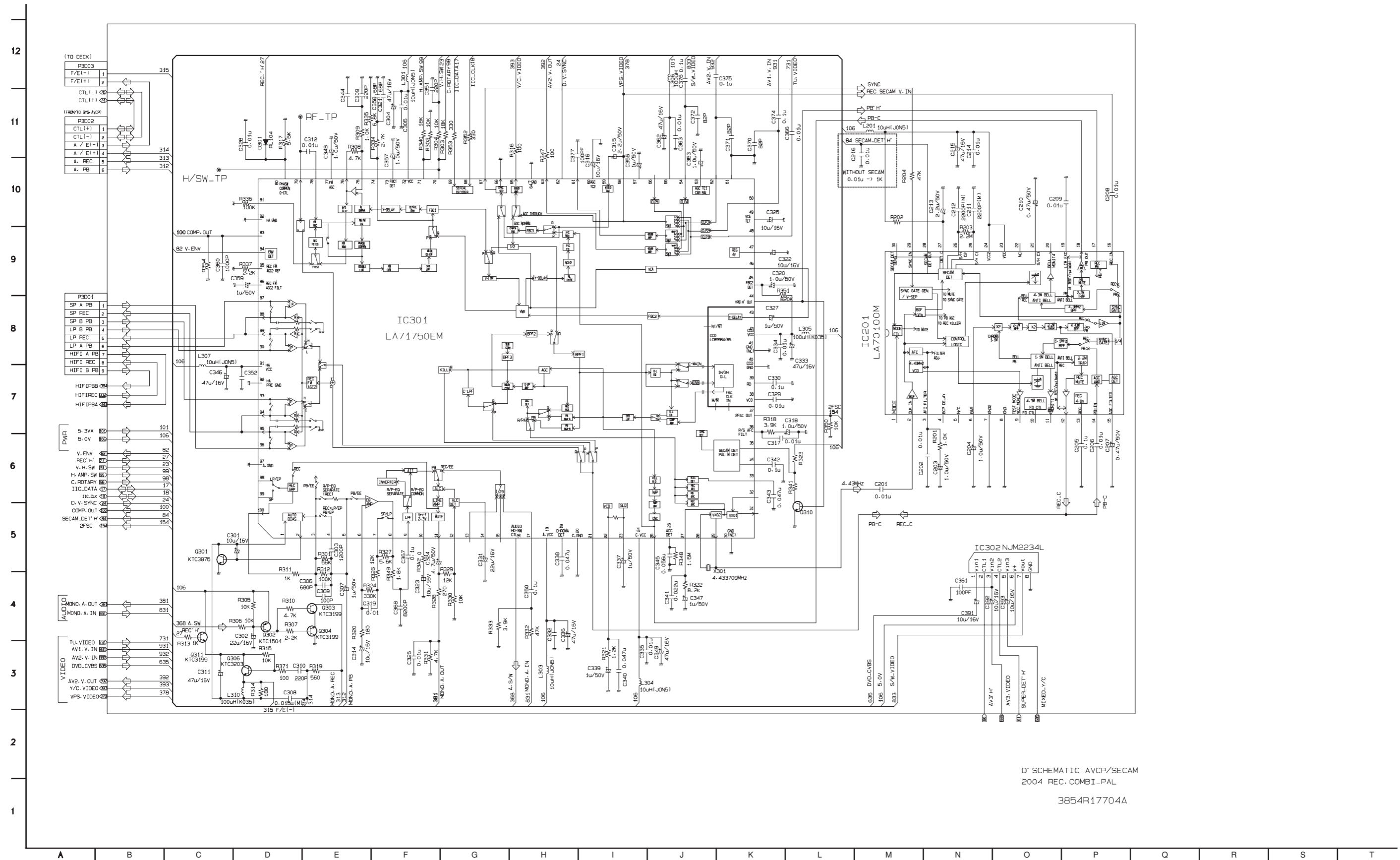

D' SCHEMATIC AVCP/SECAM
2004 REC. COMBI-PAL
3854R17704A

4. Hi-Fi CIRCUIT DIAGRAM

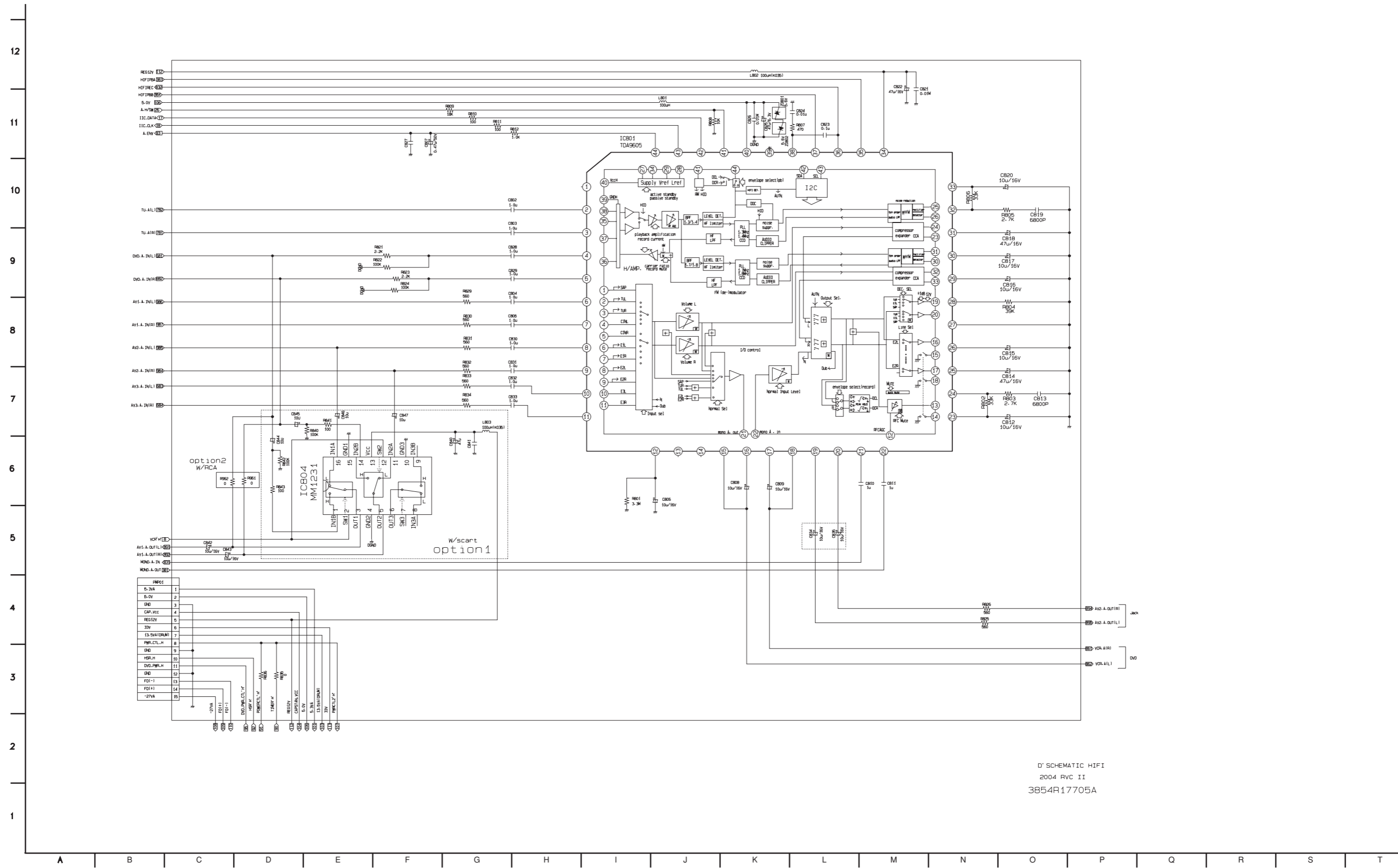

5. SYSTEM CIRCUIT DIAGRAM

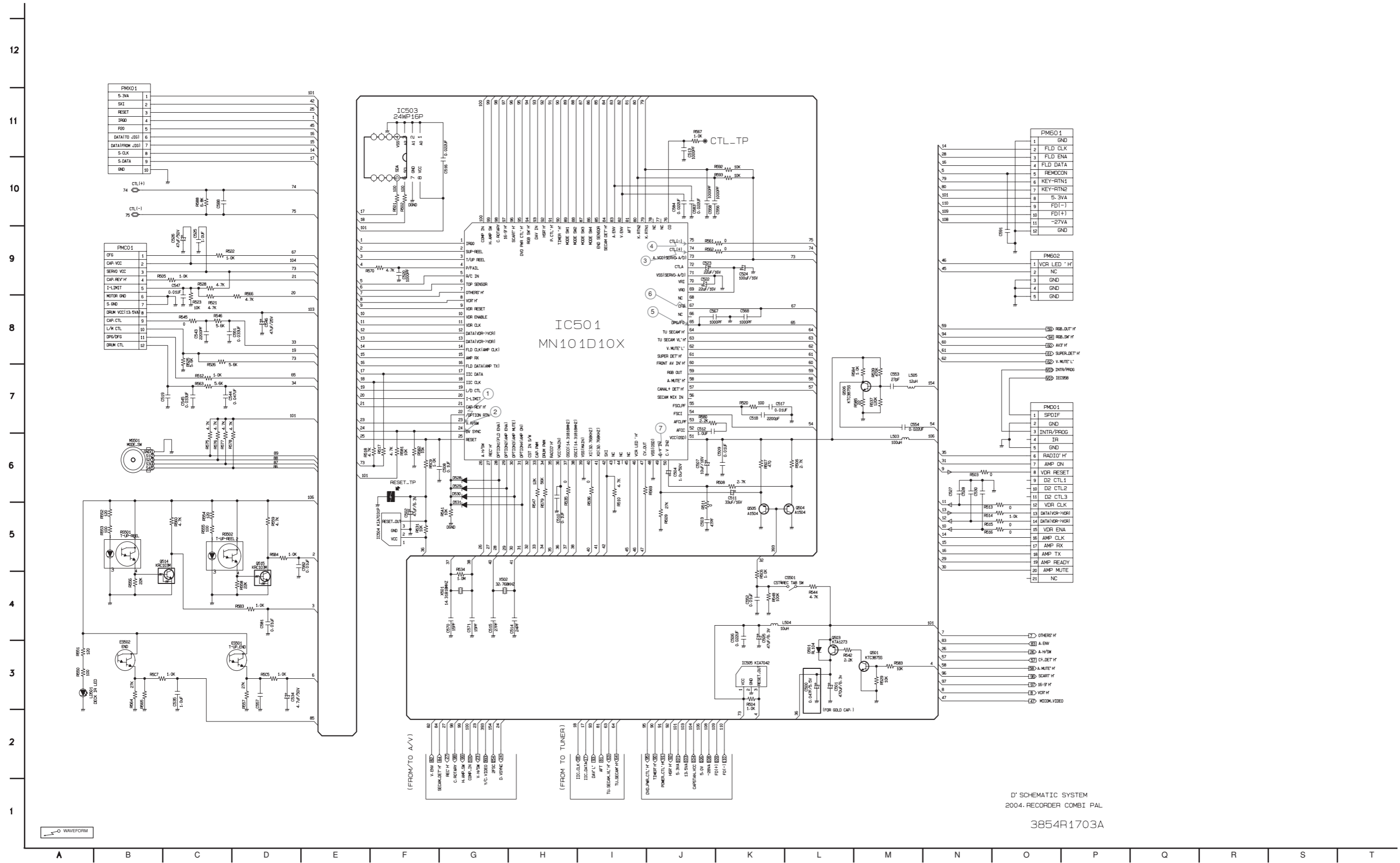

D' SCHEMATIC SYSTEM
2004.RECORDER COMBI PAL
3854R1703A

6. SCART(JACK) CIRCUIT DIAGRAM (SCART Model Only)

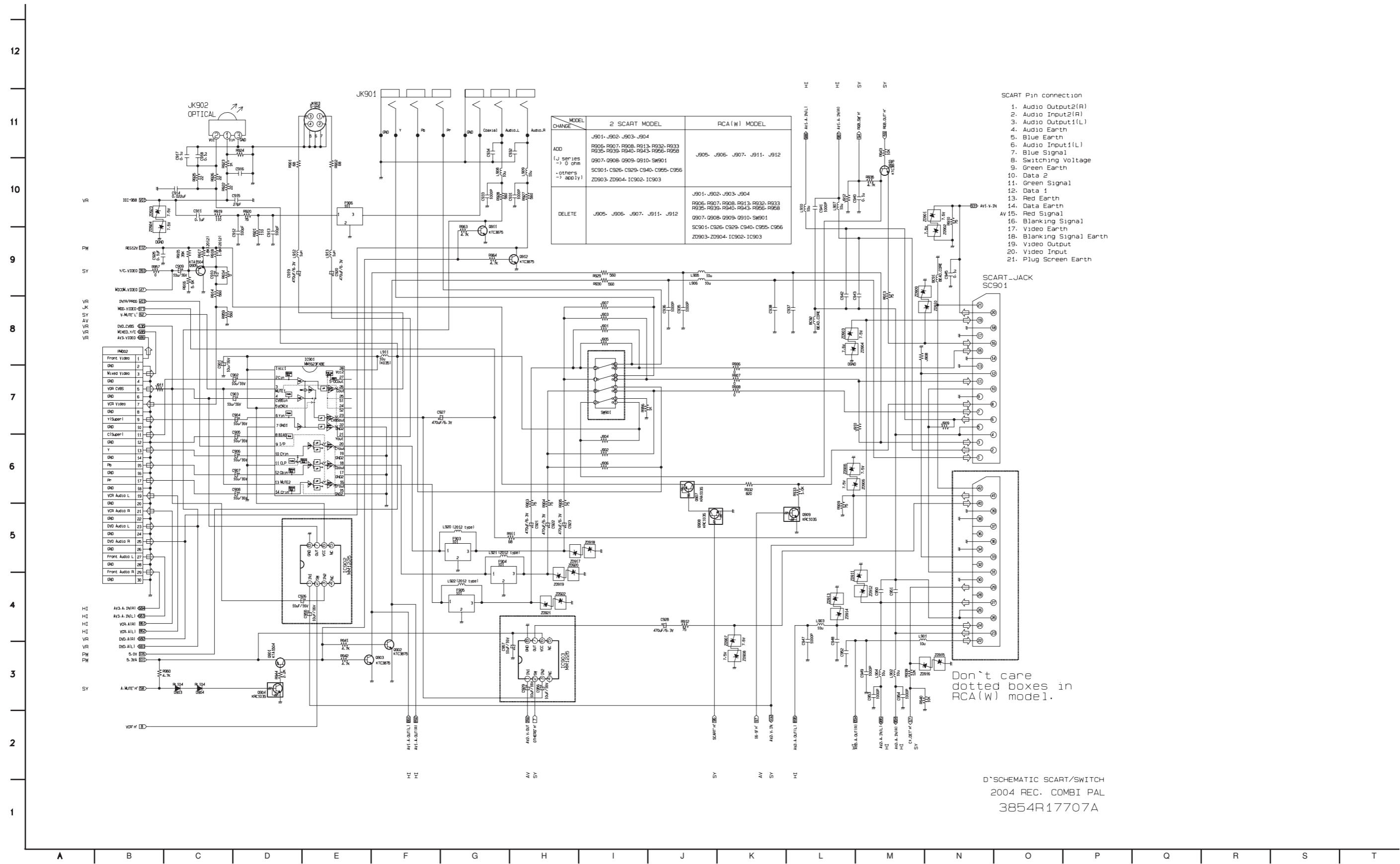

7. TIMER CIRCUIT DIAGRAM

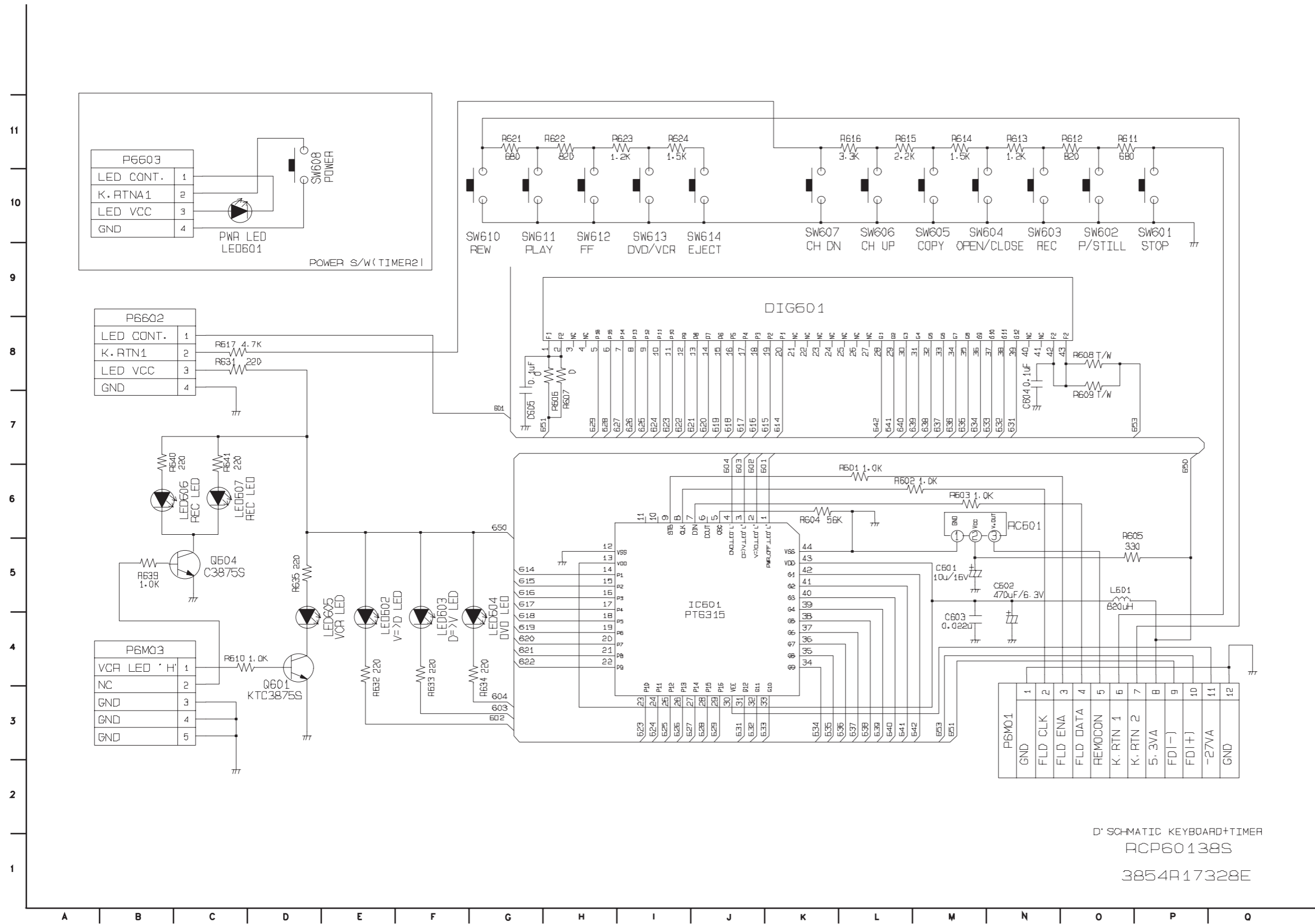

D' SCHMATIC KEYBOARD+TIMER
RCP60138S
3854R17328E

WAVEFORMS

◆ IC301 Oscilloscope Waveform

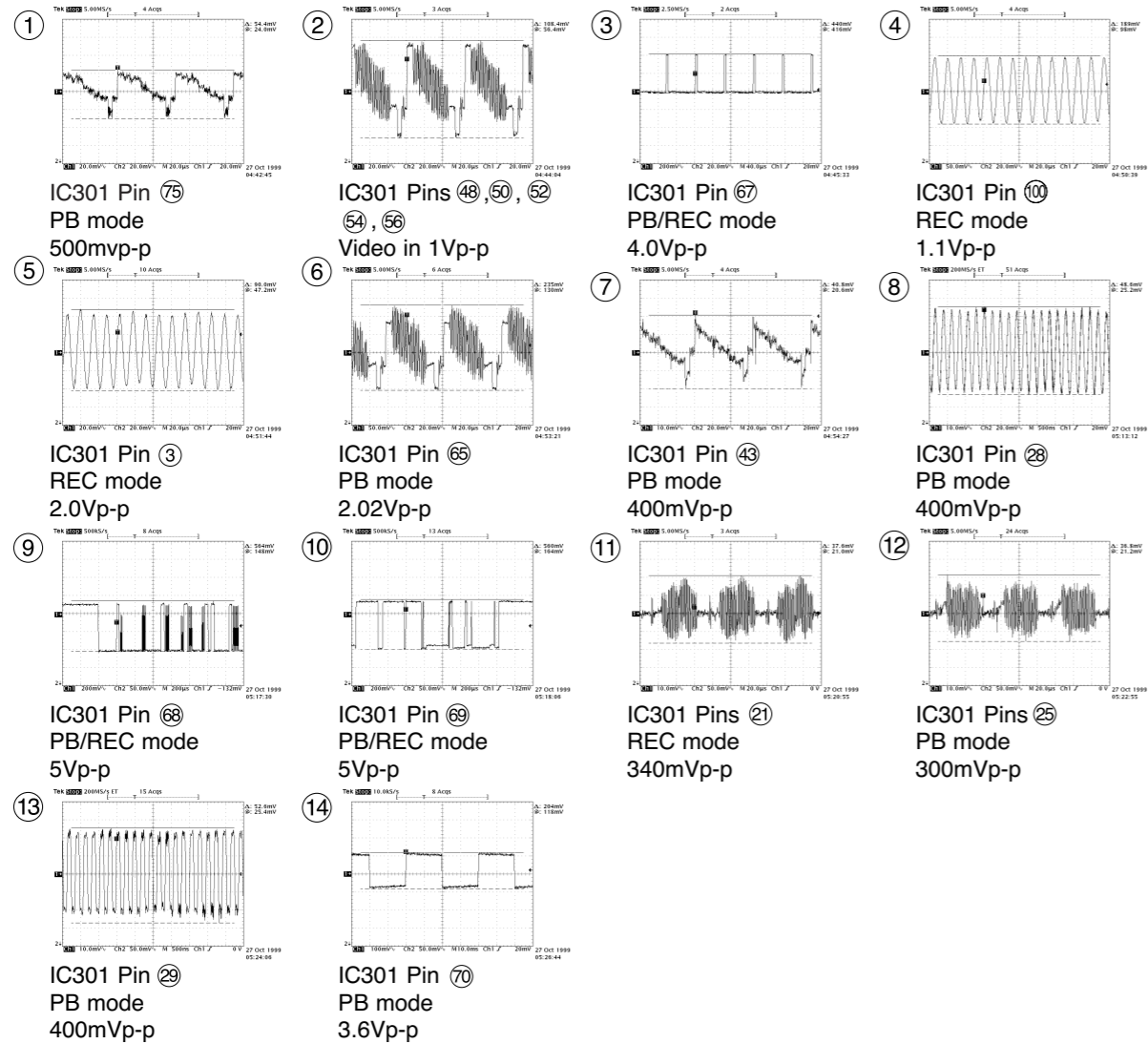

◆ IC501 Waveform Photographs

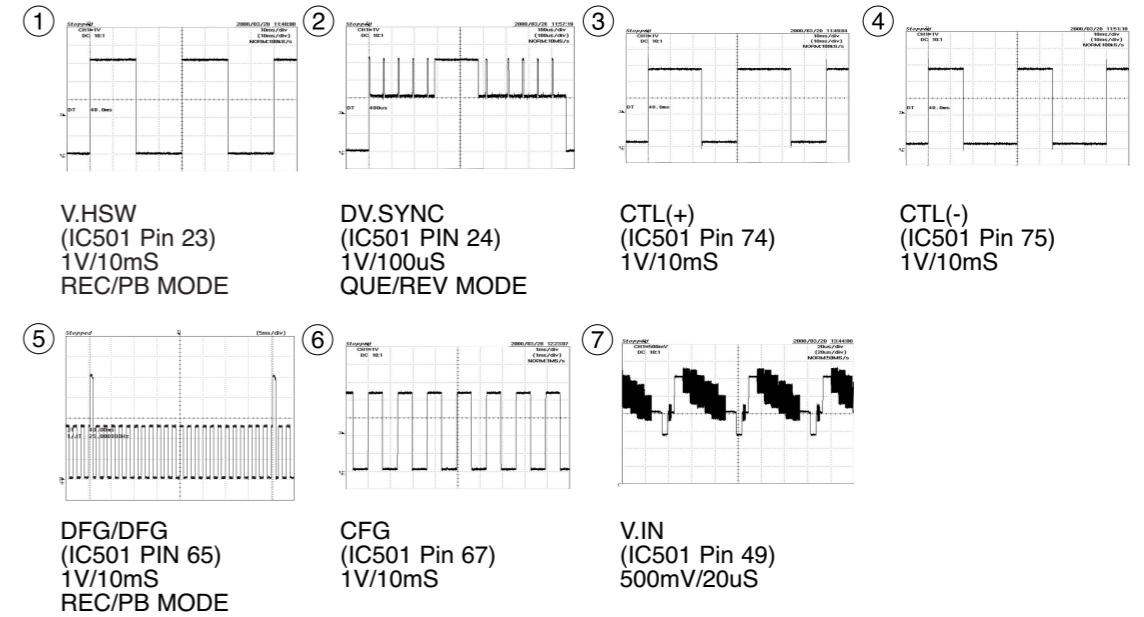

• CIRCUIT VOLTAGE CHART

MODE PIN NO.	EE	PLAY	MODE PIN NO.	EE	PLAY	MODE PIN NO.	EE	PLAY	MODE PIN NO.	EE	PLAY	MODE PIN NO.	EE	PLAY	MODE PIN NO.	EE	PLAY	MODE PIN NO.	EE	PLAY				
IC 301			55	5.23	5.24	9	5.18	5.2	64	5.26	5.24	18	0	4.97	7		3.82	18	2.32	2.3	4	0	0	
1	5.03	77.2m	56	2.45	2.36	10	Da/Clk(5.18)	0	65	0	Da/Clk(2.71)	19	5.15	4.97	8		3.82	19	0	-0.08	5	6	5.96	
2	8.5m	8.1mV	57	2.13	2.14	11	Da/Clk(5.18)	0	66	0	Da/Clk	20	0	0	9		3.81	20	1.04	-0.08	6	5.99	5.94	
3	2.37	2.37	58	2.36	2.44	12	0	0	67	4.85	Da/Clk(4.89)	21	0	0	10		3.82	21	1.04	1.01	7	22.3m	21.3m	
4	1.06	1.37	59	2.92	2.92	13	0	0	68	0	Da/Clk	22	0	5.01	11	3.82	3.82	22	0	-0.08	8	6.68	6.65	
5	2.36	2.36	60	1.42	1.56	14	Da/Clk(5.48)	5.59	69	2.53	2.61	23	0	0	12	1.3m	4.3m	23	1.48	1.89	9	6.7	6.67	
6	2.36	2.36	61	2.2	2	15	Da/Clk(2.12)	1.88	70	2.53	2.61	24	0	0	13	3.86	3.87	24	0	-0.04	10	1.1m	0	
7	2.35	2.35	62	146.5m	147.1m	16	Da/Clk(5.46)	5.56	71	0	0	25	0	0	14	6.5	1.1m	25	0	-0.07	11	6.71	6.68	
8	2.35	2.35	63	1.94	2.53	17	Da/Clk(5.32)	5.44	72	2.53	2.61	26	0	0	15	7m	1.7m	26	2.32	2.2	12	5.04	5.05	
9	2.33	2.34	64	0	0	18	Da/Clk(5.32)	5.28	73	5.26	5.2	27	0	0	16	6.07	6.08	27	0	-0.05	13	12.03	11.99	
10	2.36	2.36	65	1.98	1.82	19	Da/Clk(2.58)	2.66	74	2.53	2.57	28	0	0	17	6.08	6.08	28	4.88	4.86	14	6.7	6.7	
11	2.41	2.48	66	0	0	20	38m	3.59	75	2.53	2.57	29	0	0	18	6.7m	3.2m	IC 901			15	0	0	
12	0	0	67	355.2m	352.4m	21	0	0	76	2.49	2.61	30	SC_out(2.77)	SC_out(2.77)	19	6.07	6.08	1	2.51	2.51	16	6.73	6.69	
13	2.33	2.34	68	5.04	5.02	22	0	0	77	0	0	31	SC_out(2.77)	SC_out(2.78)	20	6.08	6.08	2	2.39	2.39	IC 902			
14	17.9m	17.9m	69	5.2	5.18	23	5.11	5.38	78	0	0	32	0	0	21	4.59	4.59	3	3.54	3.53	1	1.3	1.3	
15	2.34	2.33	70	5.22	2.74	24	1640m	140m	79	5.25	5.21	33	5.1	4.94	22	3.82	3.82	4	2.57	2.56	2	4.9	4.9	
16	5.05	213.1	71	1.84	5.4m	25	5.11	5.27	80	5.25	5.21	34	4.25	4.17	23	3.74	3.87	5	1.52	1.34	3	1.66	1.56	
17	2.33	2.33	72	5.02	5.05	26	0	5.22	81	2.68	2.44	35	0	0	24	3.71	3.87	6	0.43	3.68	4	0	0	
18	5.06	5.06	73	2.25	1.97	27	0	0	82	600m	Da/Clk	36	2.8	2.64	25	3.87	3.89	7	1.3m	0	5	0	0	
19	4.03	4.04	74	2.55	2.6	28	Da/Clk(5.28)	5.34	83	0	Da/Clk	37	0	0	26	0.757	0.786	8	1.2m	0	6	4.9	4.9	
20	0	0	75	2.49	0.712	29	5.28	5.34	84	200m	210m	38	0	0	27	1.3m	1.8m	9	3.04	3.03	7	1.7	1.6	
21	3.21	1.98	76	2.49	0.803	30	5.28	5.34	85	4.19	0	39	0	0	28	3.83	3.83	10	2.52	2.52	8	0	0	
22	3.4	3.33	77	1.59	1.52	31	0	5.34	86	0	5.32	40	2.8	2.64	29	3.86	3.86	11	2	2.05	IC 903			
23	3.4	3.32	78	2.62	3.33	32	0	4.8	87	0	5.32	41	2.8	2.64	30	0.76	0.739	12	3.22	1.97	1	1.37	1.37	
24	5.04	5.04	79	2.04	1.91	33	0	Da/Clk(5.34)	88	5.16	5.24	42	2.62	2.43	31	3.87	3.88	13	3.99	3.99	2	5	5	
25	110.5m	3.35	80	0.982	0.983	34	0	Da/Clk(5.34)	89	5.16	0	43	Mono_in(3.16)	2.43	32	3.83	3.81	14	2.5	2.495	3	2.18	2.17	
26	1.59	1.68	81	1.1	1.1	35	0	Da/Clk(136m)	90	5.16	5.24	44	0	0	33	3.75	3.82	15	3.11	1.93	4	0	0	
27	2.17	2.15	82	0	0	36	5.28	5.29	91	0	0	IC 7 V1			34	11.98	11.9	16	3.2	3.18	5	0	0	
28	3.94	3.94	83	1.36	1.14	37	Da/Clk(5.72)	Da/Clk(5.5)	92	0	0	1	0	0	35	0.64	0.649	17	27.4m	4.11	6	5.21	5.21	
29	2.59	2.62	84	0.642	2.14	38	Da/Clk(4.42)	Da/Clk(4.37)	93	5.16	5.21	2	0	0	36	53m	0.651	18	112.1m	3.35	7	2	2.17	
30	0	0	85	0	0	39	0	0	94	5.16	5.07	3	0	142M	37	0.64	0.652	19	2.27	2.26	8	0	0	
31	95.4m	103.2m	86	260.3m	226.9m	40	Da/Clk(2.93)	Da/Clk(2.93)	95	5.16	5.24	4	DA/CL(5.34)	DA/CL(5.34)	38	3.5m	4.1m	20	1.99	2.12				
32	4.56	4.69	87	1.84	0.8	41	Da/Clk(5.62)	Da/Clk(5.62)	96	5.16	5.21	5	DA/CL(5.34)	DA/CL(5.34)	39	1m	1.4m	21	2.31	2.37				
33	2.93	1.97	88	1.84	0.8	42	0	0	97	0	0	6	0	0	40	5.01	4.99	22	0.78	0.81				
34	1.83	1.81	89	1.84	0.8	43	0	0	98	5.16	Da/Clk	7	DA/CL(5.34)	DA/CL(5.34)	41	7.1m	0.898	23	5.02	5.01				
35	2.56	2.54	90	1.83	0.8	44	0	0	99	0	0	8	0	0	42	5.19	5.18	24	5.02	5				
36	3.68	3.61	91	5.03	5.06	45	0	0	100	760m	0	9	DA/CL(5.34)	DA/CL(5.34)	43	5.04	5.03	25	2.44	2.27				
37	1.9	1.93	92	0	0	46	4.07	4.11	IC 7 51			10	DA/CL(5.34)	DA/CL(5.34)	44	3.13	2.06	26	2.44	2.26				
38	1.82	1.84	93	0.83	1.88	47	Da/Clk(2.27)	Da/Clk(2.5)	1	5	5.05	11	0	41M	IC 901			27	2.82	2.85				
39	9.2	9.17	94	0.83	1.88	48	0	0	2	SIF(1.77)	1.8	12	DA/CL(2.82)	DA/CL(2.82)	1	4.88	4.8	28	181.5m	187.4m				
40	0	0	95	0.81	1.88	49	Da/Clk(2.27)	Da/Clk(2.49)	3	1.54	1.63	13	0	0	2	2.08	1.81	29	371.6m	212.2m				
41	0	0	96	0.83	1.88	50	Da/Clk(2)	Da/Clk(2.08)	4	0	0	14	DA/CL(2.82)	DA/CL(62M)	3	1.6	1.4	30	2.08	2.08				
42	4.98	4.96	97	0	0	51	5.03	4.95	5	4.42	800m	15	2.89	1.41	4	4.88	4.86	IC 302						
43	2.49	2.46	98	2.36	2.38	52	Da/Clk(1.43)	Da/Clk(1.59)	6	4.25	600m	16	1.53	950M	5	0	1.01	1	3	3.04	3.04			
44	26.3m	4.14	99	2.36	2.38	53	Da/Clk(2.31)	Da/Clk(2.32)	7	0	0	17	DA/CL(1.14)	DA/CL(810M)	6	0	-0.07	2	36.3m	38.1m				
45	2.5	2.57	100	2.36	2.38	54	Da/Clk(2.41)	Da/Clk(2.32)	8	0	4.9	18	0	0	7	2.31	-0.07	3	3.04	3.04				
46	2.67	2.62	IC 501			55	1.84	0	9	0	4.9	19	5.26	5.24	8	0	-0.07	4	6.4m	39.1m				
47	4.14	4.11	1	0	0	56	0	0	10	0	0	20	5.26	5.24	9	0	1	5	3.04	3.04				
48	2.32	2.5	2	4.94	Da/Clk(4.88)	57	0	0	11	5.11	5.14	IC 801			10	0	-0.07	6	5.02	5.03				
49	3.16	3.14	3	4.91	Da/Clk(4.86)	58	0	0	12	5.26	5.14	1	3.82	3.82	11	2	1.93	7	2.24	2.23				
50	1.94	2.92	4	4.86	4.88	59	5.26	5.24	13	5.26	5.14	2		3.82	12	0	5	8	0	0				
51	0	0	5	Da/Clk(4.86)	4.88	60	0	0	14	0	0	3		3.82	13	2	1.93	IC 804						
52	1.95	1.95	6	4.24	0	61	0	0	15	0	0	4		3.82	14	0	-0.07	1	6.71	6.66				
53	2.34	2.3	7	0	0	62	5.06	5.24	16	0	0	5		3.81	15	2.32	2.31	2	5.05	5.05				
54	2.46	2.37	8	5.06	5	63	0	0	17	0	4.97	6		3.82	16	0	-0.07	3	6.02	5.96				

E-MODE NO.	E	C	B
Q501	0	0	740M
Q503	5.19	5.19	4.57
Q504	Y/C_VIDEO	0	Y/C_VIDEO
Q505	Y/C_VIDEO	0	Y/C_VIDEO
Q506	0	2Fsc	2Fsc
Q514	0	0	4.87
Q515	0	0	4.87
Q301	0	5.04	0
Q302	5.04	0	5.04
Q303	0	0	0
Q304	0	0	0
Q306	4.93	4.81	4.79
Q308	Y/C_VIDEO	0	Y/C_VIDEO
Q311	5.04	5.04	0
Q7S1	0	1.47	0
Q7S2	0	0	5.13
Q901	5.1	0	4.5
Q902	0	0	0
Q903	0	0	0
Q904	0	4.5	0
Q905	2.69	0	2
Q906	1.7	0	1.7
Q907	11.9	11.8	0
Q908	0	0	5
Q909	0	7.4	0
Q910	4.6	5	5.1

SECTION NO.	EE		PLAY	
	+	-	+	-
C203	3.55	0	3.51	0
C204	3.34	0	3.59	0
C207	3.12	0	1.93	0
C210	2.26	0	2.94	0
C213	3.29	0	2.77	0
C215	4.97	0	4.89	0
C301	5.01	0	0	0
C302	5.03	0	4.24	0
C304	4.99	0	4.85	0
C307	2.29	4.87	2.27	0
C311	5.11	5	190M	0
C314	2.35	0	2.31	0
C315	2.92	2.79	2.83	2.31
C316	1.48	0	1.57	0
C318	4.1	0	2.85	0
C320	2.39	0	2.2	0
C322	4.13	0	4.09	0
C323	2.35	0	2.31	0
C324	2.42	0	0	0
C325	2.95	0	3.13	0
C327	2.61	2.46	3.18(Y/C)	3.18(Y/C)
C331	17.5M	0	0	0
C333	4.94	0	4.88	0
C336	5.04	0	5.01	0
C337	3.36	0	2.53	0
C339	3.38	0	2.62	0
C346	5	0	4.91	0
C347	2.16	0	2.14	0
C348	1.62	0	1.5	0
C349	5.02	0	4.92	0
C353	2.31	0	2.25	0
C356	1.97	0	2.07	0
C357	2.17	0	2.02	0
C359	264M	0	130M	0
C362	5.2	0	5.19	0
C391	2.99	2.7	3.02	780M
C392	3.03	2.75	3.07	2.75
C393	3.03	2.76	3.12	0
C501	5.2	0	5.19	0
C502	5.19	0	5.19	0
C504	2.36	2.06	2.3	2
C505	5.22	0	5.19	0
C507	4.95	0	4.95	0
C511	2.41	1.32	2.41	1.3
C522	2.61	0	2.64	0
C523	2.61	2.61	2.64	0
C524	2.61	0	2.64	0
C526	16.74	0	13.6	0
C534	4.24	0	62M	0
C546	14.73	0	14.2	0
C7S1	4.9	4.17	4.85	4.09
C7S2	4.9	0	4.85	0
C7V1	5.22	0.91	5.28	0
C7V3	2.86	1.47	2.16	950M
C710	32.61	0	32.4	0

SECTION NO.	EE		PLAY	
	+	-	+	-
C718	5.05	0	4.96	0
C719	5.04	0	4.96	0
C724	2.39	164M	2.31	0

• IC BLOCK DIAGRAMS

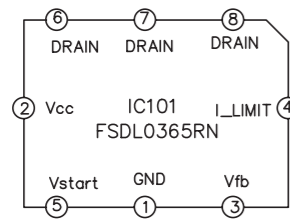

IC101_FSDL0365RN

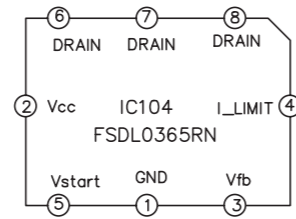

IC104_FSDL0365RN

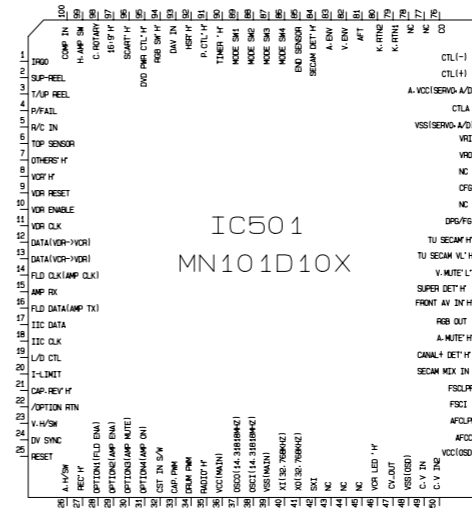

IC501_MN101D10X

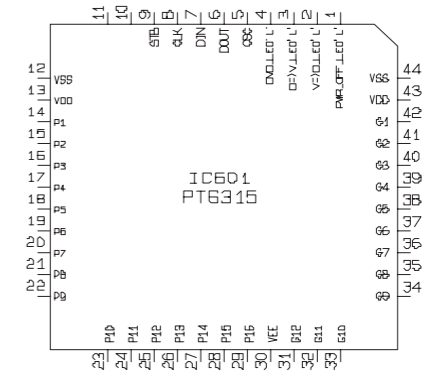

IC601_PT6315

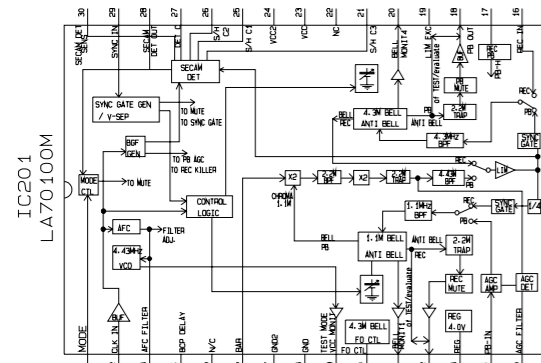

IC201_LA70100M

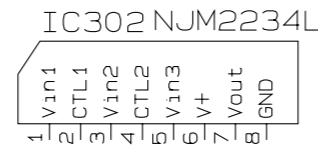

IC302_NJM2234L

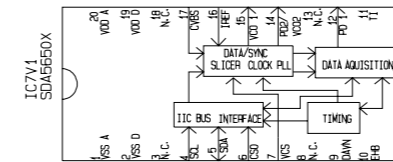

IC7V1_SDA5650X

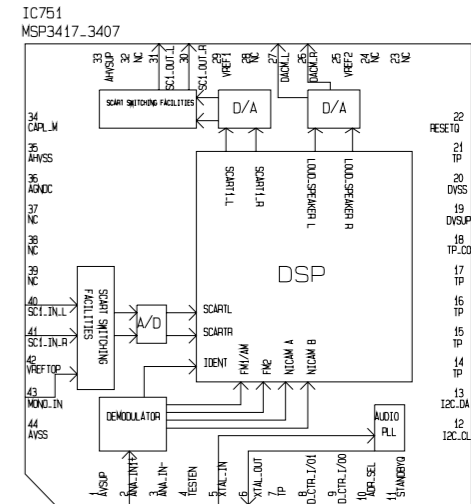

IC751_MSP3417_3407

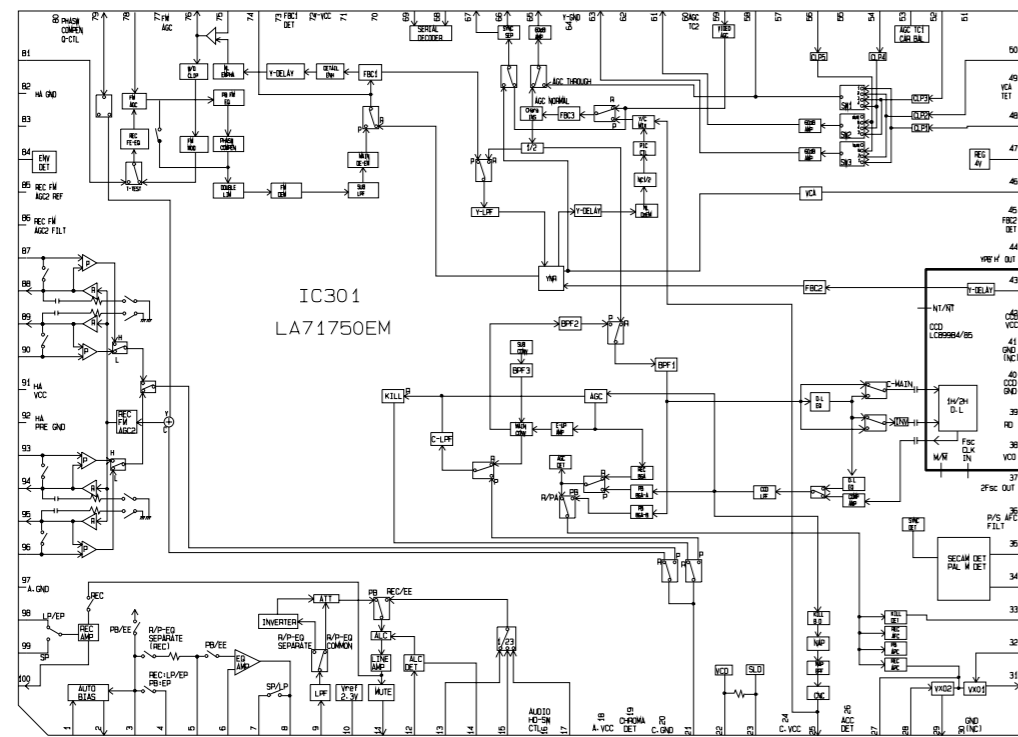

IC301_LA71750EM

MEMO

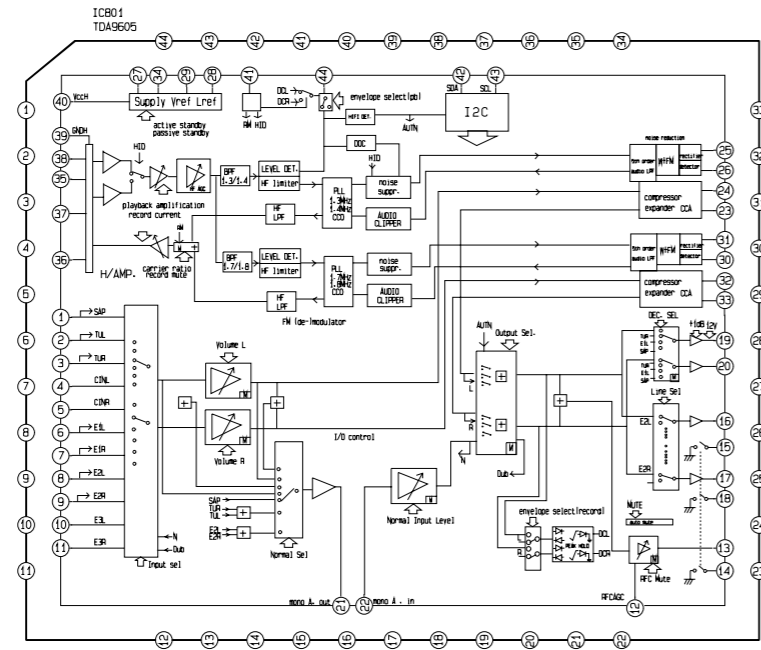

IC801_TDA9605

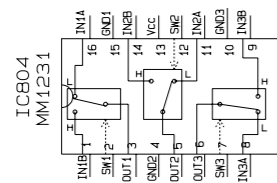

IC804_MM1231

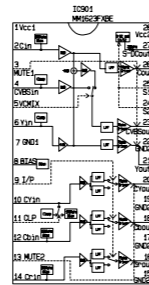

IC901_MM1623FXBE

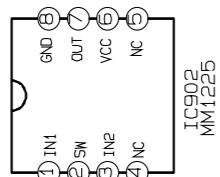

IC902_MM1225

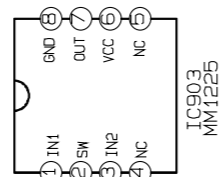

IC903_MM1225

PRINTED CIRCUIT DIAGRAMS

1. VCR P.C.BOARD(TOP VIEW)

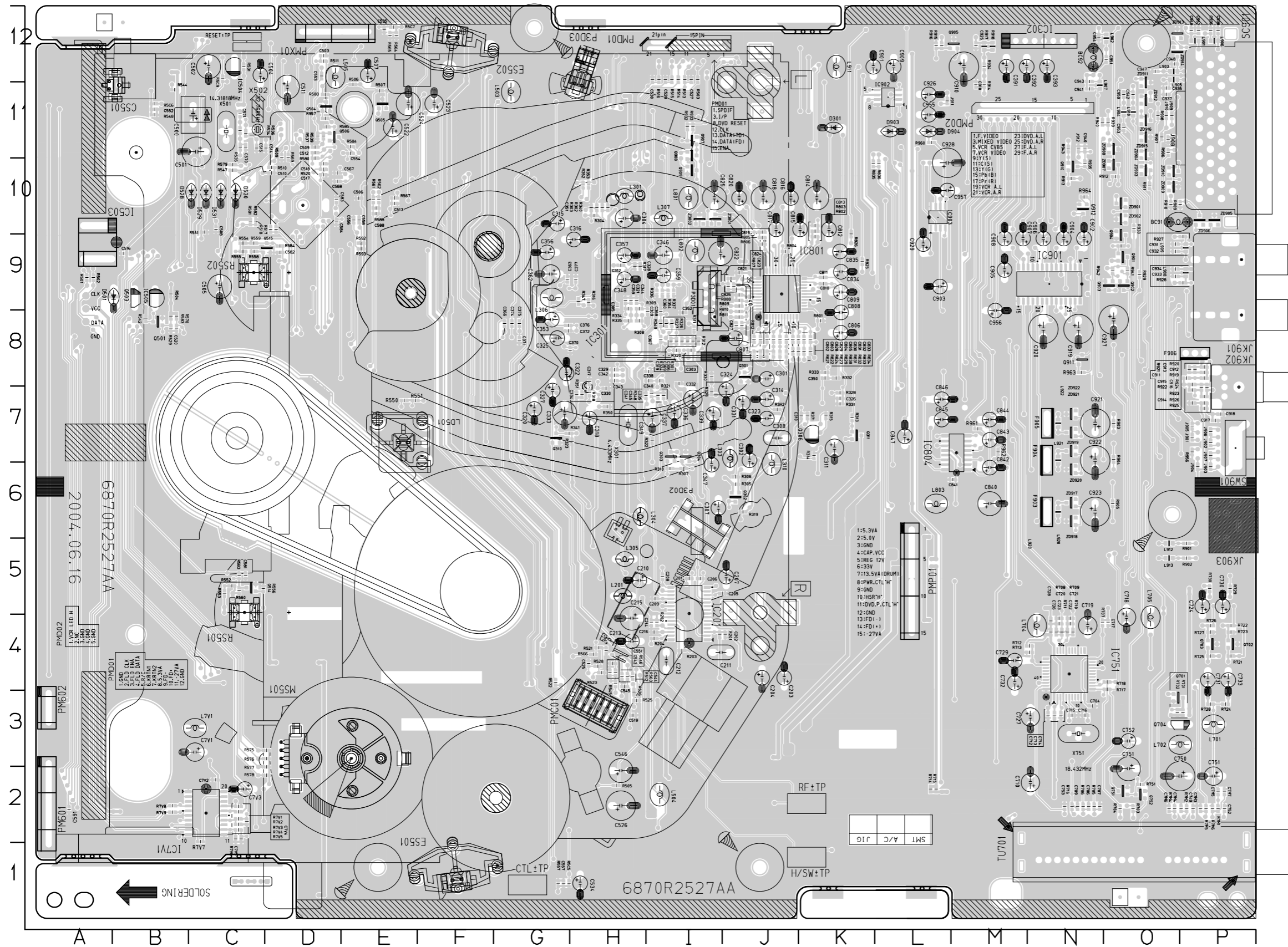

LOCATION GUIDE

BC91	010	C367	I8	C719	N4	C906	N9	J904	P6	PIN0032 K7	FIN0171 D10	Q501	B8	R503	I12	R702	O3	R911	O10
BC92	N12	C368	I8	C720	N4	C907	M9	J905	P7	PIN0033 H10	FIN0172 D11	Q503	B9	R504	B9	R703	O2	R912	O10
C201	15	C369	I8	C721	N4	C908	M9	J906	P7	FIN0035 G8	FIN0194 N3	Q504	D11	R505	H2	R704	O2	R913	N10
C202	J4	C370	H8	C722	N4	C909	L12	J907	P7	FIN0036 I8	FIN0195 N4	Q505	E11	R506	E11	R705	N2	R914	M11
C203	J4	C371	G8	C723	N4	C910	M12	J908	O11	FIN0037 I8	FIN0217 K9	Q506	D11	R507	E11	R706	N2	R915	L12
C204	J4	C372	G8	C724	P5	C911	P8	J909	O11	FIN0038 H8	FIN0218 J9	Q514	C5	R508	D11	R707	N4	R916	L12
C205	J5	C374	G8	C726	N4	C912	P8	J910	O11	FIN0040 H8	FIN0219 J9	Q515	D9	R509	D11	R708	N4	R917	M12
C206	15	C375	G8	C727	N3	C913	P8	J911	L11	FIN0041 G9	FIN0220 J9	Q701	O3	R510	D10	R709	N4	R918	M12
C207	J5	C376	G8	C728	N4	C914	P7	J912	N11	FIN0042 D10	FIN0221 J9	Q702	P4	R511	D12	R710	N4	R919	P8
C208	15	C377	H9	C729	M4	C915	P8	JK901	P8	FIN0043 D11	FIN0222 J8	Q703	P4	R512	H4	R711	N4	R920	P8
C209	15	C391	M12	C730	P5	C916	P7	JK902	P7	FIN0044 E10	FIN0223 J8	Q704	P3	R513	I12	R712	N4	R921	P8
C210	H5	C392	M12	C731	P4	C917	P7	JK903	P6	FIN0045 D10	FIN0224 M7	Q751	O2	R514	I12	R713	N4	R922	P7
C211	14	C393	N12	C732	M4	C918	P7	L201	H5	FIN0046 D11	FIN0226 M7	Q752	O2	R515	I12	R714	L2	R923	P7
C212	14	C500	C11	C733	P4	C919	N8	L301	H10	FIN0047 B8	FIN0227 L7	Q901	O9	R516	I12	R715	L2	R924	P7
C213	H4	C501	C11	C749	P2	C920	N8	L303	J7	FIN0048 I11	FIN0228 N9	Q902	O9	R517	D10	R716	N2	R925	P7
C214	14	C502	C12	C750	P2	C921	N7	L304	H6	FIN0049 H10	FIN0229 N8	Q903	O9	R518	D10	R717	O4	R926	P7
C215	H4	C503	D12	C751	P2	C922	N7	L305	H5	FIN0050 I11	FIN0230 N8	Q904	O9	R520	D10	R718	O4	R927	P9
C216	14	C504	C12	C752	P2	C923	N6	L306	G9	FIN0051 E12	FIN0231 L11	Q905	M12	R521	H4	R721	P4	R928	P9
C301	J8	C505	C9	C7M3	P2	C925	M12	L307	I10	FIN0052 H4	FIN0232 K11	Q907	I11	R522	G4	R722	P4	R929	O9
C302	J7	C506	E10	C7M4	P2	C926	L11	L310	J6	FIN0055 D11	FIN0233 L9	Q908	I11	R523	H4	R723	P4	R930	O10
C303	18	C507	E12	C7M5	P2	C927	O8	L503	G11	FIN0056 E11	FIN0234 L10	Q909	I10	R525	H3	R724	P3	R932	I11
C304	H10	C508	C10	C7M6	O2	C928	L10	L504	I2	FIN0057 E10	FIN0235 O11	Q910	N10	R526	H3	R725	P4	R933	I11
C305	H9	C509	D11	C7M7	P2	C929	L9	L505	D12	FIN0058 D10	FIN0236 O5	Q911	N8	R528	H4	R726	P4	R934	M12
C306	18	C510	D10	C751	O2	C931	O9	L701	P3	FIN0059 E10	FIN0237 O5	Q912	N10	R529	B8	R727	P4	R935	N10
C307	16	C511	D11	C752	O3	C932	O9	L702	P3	FIN0060 O5	FIN0238 O2	R201	I4	R531	C12	R728	P3	R939	O11
C308	J7	C512	D11	C753	N2	C933	O9	L704	N4	FIN0061 D9	FIN0239 J6	R202	I4	R534	C11	R729	P5	R940	N11
C309	18	C513	E10	C7V1	C3	C934	O9	L705	O4	FIN0062 E10	FIN0240 I7	R203	I4	R535	C11	R730	P5	R941	O9
C310	K7	C514	D11	C7V2	C2	C935	O11	L7V1	C3	FIN0063 N2	FIN0241 I6	R204	I4	R536	C11	R7M1	P2	R942	O9
C311	K7	C515	C11	C7V3	C2	C936	P12	L801	I10	FIN0064 N3	FIN0242 I6	R301	I8	R537	D11	R7M2	P2	R943	N11
C312	H9	C516	B9	C7V4	C2	C937	O11	L802	I9	FIN0065 N3	FIN0243 G7	R302	H10	R539	D11	R7M4	O2	R944	O9
C314	J7	C517	D10	C7V5	C2	C938	P12	L803	L6	FIN0066 N5	FIN0244 K7	R303	H10	R542	B8	R7M5	P2	R956	P7
C315	G10	C518	D10	C802	J8	C940	N11	L901	P12	FIN0067 N5	FIN0245 B8	R304	H10	R544	B11	R7M6	P2	R957	D11
C316	H9	C519	H3	C803	J8	C941	N11	L902	O12	FIN0068 N4	FIN0246 B8	R305	J6	R545	H4	R751	O2	R959	M11
C317	H8	C520	B8	C804	J8	C942	O11	L903	O12	FIN0069 N4	FIN0247 D11	R306	J6	R546	H4	R7V1	C2	R960	L11
C318	H7	C522	E11	C805	J8	C943	N11	L904	O11	FIN0070 J8	FIN0249 D11	R307	I6	R547	C10	R7V2	C2	R961	M7
C319	18	C523	F11	C806	K8	C947	O12	L905	O12	FIN0071 J8	FIN0250 C5	R308	H8	R548	B11	R7V3	C2	R962	M7
C320	G7	C524	E11	C807	J8	C948	O12	L906	P12	FIN0073 J8	FIN0251 D9	R309	H9	R550	E7	R7V4	C2	R963	N8
C321	H9	C525	H4	C808	K8	C949	P12	L907	N11	FIN0075 J8	FIN0252 O3	R310	I6	R551	E7	R7V5	C2	R964	N10
C322	G8	C526	H2	C809	K9	C950	O11	L908	P9	FIN0076 K9	FIN0253 O9	R311	I8	R552	C5	R7V6	C2	RESET + TRC12	
C323	J7	C527	I12	C810	K9	C951	O12	L909	P9	FIN0077 K9	FIN0254 O9	R312	I8	R553	C5	R7V7	C2	RF+TP	K2
C324	J7	C528	I12	C811	K9	C952	P12	L910	O11	FIN0078 K9	FIN0255 O9	R313	K7	R554	C9	R7V8	B2	RS501	C5
C325	G8	C530	I12	C812	K10	C953	O11	L911	K12	FIN0079 K10	FIN0256 O9	R314	K7	R555	C9	R7V9	B2	RS502	C9
C326	K7	C534	H1	C813	K10	C954	N12	L912	O5	FIN0080 J10	FIN0257 O9	R315	K7	R556	C5	R801	K8	SC901	P10
C327	G7	C535	E12	C814	K10	C955	L11	L913	O5	FIN0081 J9	FIN0261 I11	R316	H9	R557	G1	R802	K9	SW901	P7
C328	H9	C543	H4	C815	K10	C956	M8	L920	N6	FIN0082 J9	FIN0262 I11	R317	H9	R558	C9	R803	K10	TU701	P1
C329	H8	C544	H4	C816	J10	C957	L10	L921	N7	FIN0084 J8	FIN0263 I10	R318	H7	R559	C9	R804	J9	X301	H7
C330	H7	C545	H4	C817	J10	C5501	B11	L922	N7	FIN0086 J8	FIN0264 N10	R319	J6	R560	C5	R805	J9	X501	C11
C331	J7	C546	H2	C818	J10	CTL+TP	G1	LD501	E7	FIN0088 J8	FIN0265 N11	R320	I8	R561	E10	R806	J9	X502	C11
C332	18	C547	H4	C819	J10	D301	K11	MS501	D3	FIN0090 K8	FIN0266 H4	R321	I8	R562	E10	R807	J9	X751	N3
C333	G7	C551	H4	C820	J10	D501	B9	P3D01	I8	FIN0092 K8	FIN0267 E7	R322	I7	R563	H4	R808	J9	ZD801	I10
C334	H7	C552	B11	C821	J9	D528	C10	P3D02	I6	FIN0093 K8	FIN0268 C5	R323	H7	R564	E12	R809	J9	ZD802	I10
C335	17	C553	D12	C822	I9	D529	C10	P3D03	H12	FIN0094 K8	FIN0269 C9	R324	I8	R565	E12	R810	J8	ZD901	O10
C336	17	C554	E11	C823	J9	D530	C10	FIN0001 P3		FIN0095 P8	FIN0277 I10	R326	I8	R566	H4	R811	J8	ZD902	O10
C337	17	C556	E10	C824	J9	D531	C10	FIN0002 P2		FIN0096 P8	FIN0280 O10	R327	I8	R567	E10	R812	J8	ZD903	O10
C338	18	C557	G1	C825	I10	D903	L11	FIN0003 C2		FIN0097 P7	FIN0283 O10	R328	K7	R569	D11	R821	J8	ZD904	O11
C339	17	C558	E10	C826	J9	D904	L11	FIN0004 C2		FIN0098 P9	FIN0286 P10	R329	I7	R570	B8	R822	J8	ZD905	P10
C340	18	C567	D10	C827	J8	E5501	G1	FIN0005 I5		FIN0099 P9	FIN0289 O11	R330	I8	R575	D3	R823	J8	ZD906	P10
C341	H7	C568	D10	C828	J8	E5502	E12	FIN0006 I4		FIN0102 N11	FIN0292 O10	R331	K7	R576	D3	R824	J8	ZD907	O10
C342	H8	C570	C11	C829	J8	F903	N6	FIN0007 I5		FIN0103 N11	FIN0295 O12	R332	K8	R577	D2	R825	K9	ZD908	O11
C343	H8	C571	C11	C830	J8	F904	N7	FIN0008 I5		FIN0107 B2	FIN0298 P12	R333	K8	R578	D2	R826	K9	ZD909	O10
C344	H9	C581	C5	C831	J8	F905	N7	FIN0009 I5		FIN0108 B2	FIN0301 O11	R334	H9	R579	C10	R829	J8	ZD910	O10
C345	17	C582	D9	C832	K8	F906	P8	FIN0010 I5		FIN0109 B2	FIN0304 N6	R335	H8	R580	D10	R830	J8	ZD911	O11
C346	19	C583	D10	C833	K8	H/SW+TP	K1	FIN0011 I5		FIN0110 B2	FIN0307 N6	R336	I9	R581	C10	R831	J8	ZD912	O11
C347	16	C584	D10	C834	K9	IC201	I5	FIN0013 I8		FIN0111 B2	FIN0310 N7	R337	I9	R582	C10	R832	J8	ZD913	O12
C348	H9	C588	E10	C835	K9	IC302	M12	FIN0014 I8		FIN0112 B2	PM601 A3	R340	H10	R583	B8	R833	K8	ZD914	O12
C349	17	C591	A2	C840	M6	IC503	A10	FIN0015 H9		FIN0113 C2	PM602 A3	R341	G7	R584	E11	R834	K8	ZD915	O11
C350	K8	C704	N3	C841	M6	IC504	C12	FIN0016 K7		FIN0115 C2	PMCO1 H3	R347	H9	R585	D11	R835	K10	ZD916	O11
C351	H10	C706	N2	C842	M6	IC505	B9	FIN0018 H7		FIN0116 C2	PMD01 I12	R348	I7	R588	E10	R836	L10	ZD917	N6
C352	18	C707	N2	C843	M7	IC751	N4	FIN0019 I8		FIN0125 I5	PMD02 M11	R349	I8	R592	E9	R901	P5	ZD918	N6
C353	G8	C709	N2	C844	M7	IC7V1	C2	FIN0020 I8		FIN0128 I4	PMP01 L6	R350	H7	R593	E9	R902	P5	ZD919	N7
C356	G9	C710	N2	C845	L7	IC801	J9	FIN0021 H8		FIN0130 I8	PMX01 D12	R351	H7	R5A1	C10	R903	O7	ZD920	N6
C357	H9	C712	N3	C846	L7	IC804	M7	FIN0022 K7		FIN0141 H8	Q301 J8	R352	H10	R5B3	C5	R904	O7	ZD921	N7
C358	H9	C713	N3	C847	L7	IC901	N9	FIN0023 H8		FIN0148 H8	Q302 J6	R353	H10	R5B4	D9	R905	O6	ZD922	N7
C359	19	C714	N3	C901	K12	IC902	L11	FIN0024 H8		FIN0150 H8	Q303 I7	R354	I9	R5C5	G1	R906	O11		
C360	19	C715	N3	C902	N9	IC903	L10	FIN0025 H8		FIN0152 I9	Q304 I7	R371	K7	R5C6	B11	R907	O11		
C362	G9	C716	N3	C903	L9	J901	P7	FIN0026 I8		FIN0163 D10	Q306 K7	R3A2	J7	R5C7	E12	R908	O11		
C363	G9	C717	O4	C904	N9	J902	P7	FIN0027 I7		FIN0165 O10	Q310 G7	R501	A9	R5C9	C12	R909	P10</		

LOCATION GUIDE

IC301	I8
IC501	M10
PIN0012	H4
PIN0017	I9
PIN0028	I7
PIN0029	I7
PIN0034	H9
PIN0039	J8
PIN0053	I4
PIN0054	I4
PIN0100	B12
PIN0101	A12
PIN0104	B12
PIN0105	A12
PIN0124	I5
PIN0132	G8
PIN0133	H8
PIN0136	H7
PIN0139	I7
PIN0140	J8
PIN0142	I9
PIN0143	I9
PIN0144	I9
PIN0145	I9
PIN0146	I9
PIN0147	I9
PIN0149	I9
PIN0151	H9
PIN0155	H8
PIN0156	M9
PIN0157	M9
PIN0158	M9
PIN0159	M9
PIN0160	N9
PIN0161	N9
PIN0162	N9
PIN0164	N10
PIN0166	N10
PIN0167	N11
PIN0174	L11
PIN0175	K11
PIN0176	K10
PIN0177	K10
PIN0178	K10
PIN0181	L10
PIN0182	L10
PIN0185	L9
PIN0186	L9
PIN0187	L9
PIN0188	L9
PIN0189	L9
PIN0190	L9
PIN0248	L11

2. VCR P.C.BOARD(BOTTOM VIEW)

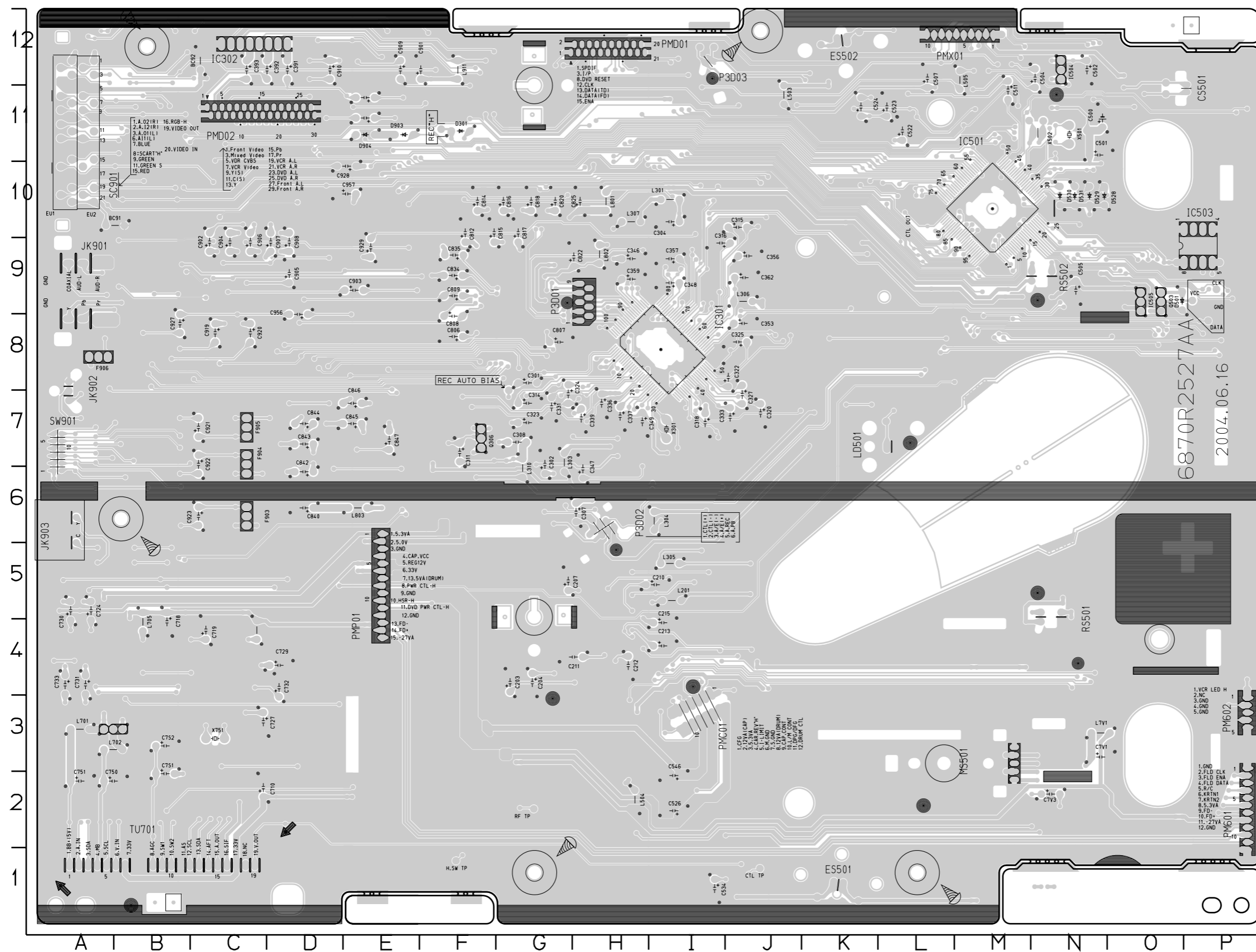

6870R2527AA
2004.06.16

3. SMPS P.C.BOARD

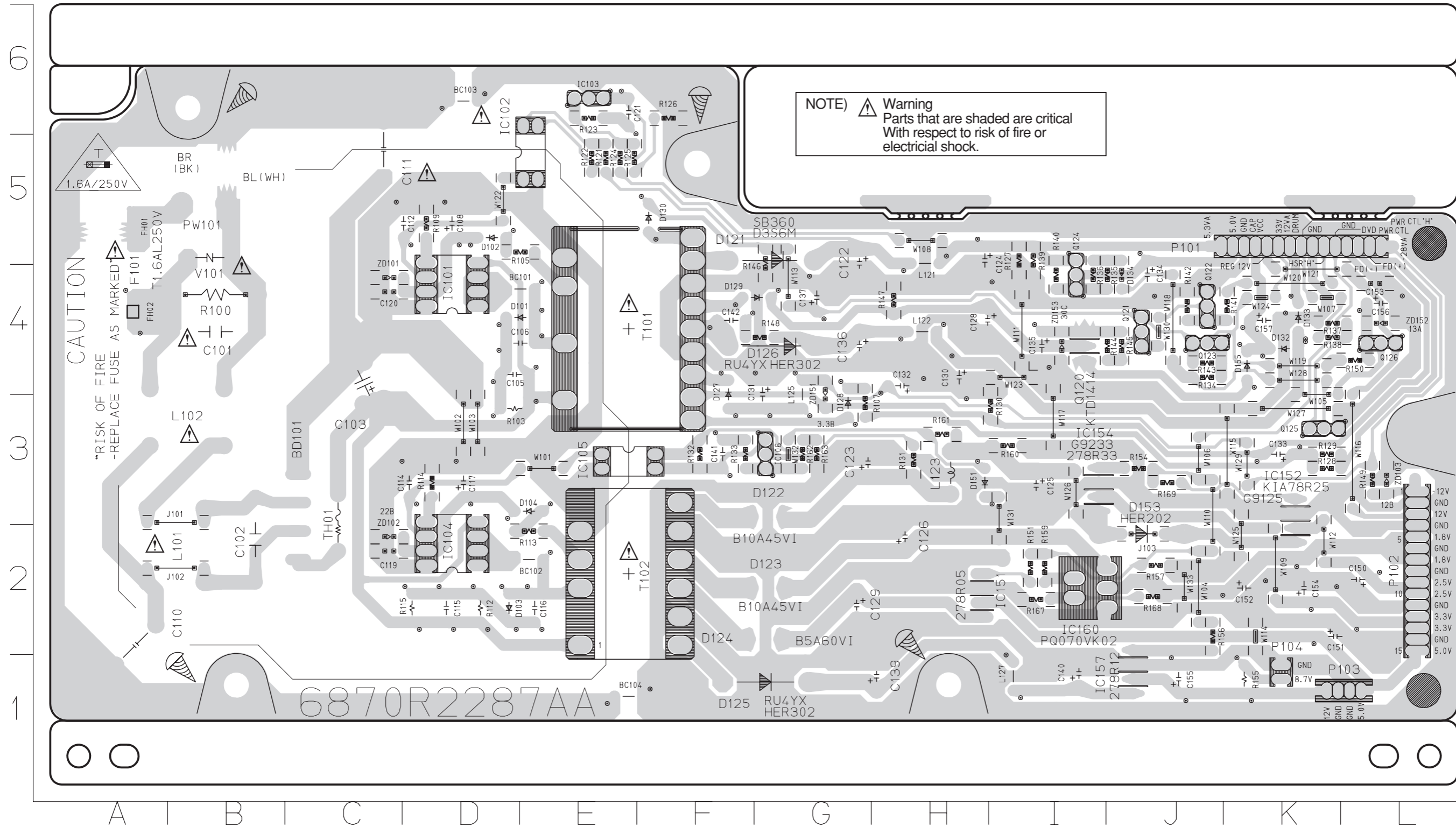

LOCATION GUIDE

BC101	E4	C152	K2	L101	B2	R135	J4
BC102	E2	C153	L4	L102	B3	R136	I4
BC103	D6	C154	K2	L121	H5	R137	K4
BC104	E1	C155	J1	L122	H4	R138	K4
BD101	C3	C156	L4	L123	H3	R139	I5
C101	B4	C157	K4	L125	G3	R140	I4
C102	B2	D101	E4	L127	I1	R141	K4
C103	C4	D102	D5	P101	J5	R142	J4
C105	D4	D103	D2	P102	L3	R143	J4
C106	E4	D104	E3	P103	K1	R144	J4
C108	D5	D121	G5	P104	K1	R145	J4
C110	A2	D122	G3	PW101	B5	R146	G5
C111	C5	D123	G2	Q120	I4	R147	H4
C112	D5	D124	G2	Q121	J4	R148	G4
C114	D3	D125	G1	Q122	J4	R149	L3
C115	D2	D126	G4	Q123	J4	R150	L4
C116	E2	D127	F3	Q124	I4	R151	I2
C117	D3	D128	G3	Q125	K3	R154	J3
C119	C2	D129	G4	Q126	L4	R155	K1
C120	C4	D130	F5	R100	B4	R156	J2
C121	E6	D132	K4	R103	D3	R157	J2
C122	G5	D133	K4	R105	E5	R159	I2
C123	G3	D134	J4	R107	G3	R160	I3
C124	H5	D151	H3	R109	D5	R161	H3
C125	I3	D153	J2	R112	D2	R162	G3
C126	H2	D155	K4	R113	E2	R163	G3
C128	H4	FH01	A5	R114	D3	R167	I2
C129	G2	FH02	A4	R115	D2	R168	J2
C130	H4	IC101	D4	R121	E5	R169	J3
C131	G3	IC102	E6	R122	E5	T101	E4
C132	H4	IC103	E6	R123	E6	T102	E2
C133	K3	IC104	D2	R124	E5	TH01	C3
C134	J4	IC105	F3	R125	E5	V101	B5
C135	I4	IC106	G3	R126	F6	ZD101	C4
C136	G4	IC151	H2	R127	I5	ZD102	C2
C137	G4	IC152	K2	R128	K3	ZD103	L3
C139	H1	IC154	I3	R129	K3	ZD151	G3
C140	I1	IC157	J1	R130	I3	ZD152	L4
C141	F3	IC160	I2	R131	H3	ZD153	I4
C142	F4	J101	B3	R132	F3		
C150	L2	J102	B2	R133	F3		
C151	K2	J103	J2	R134	J4		

4. JACK P.C.BOARD

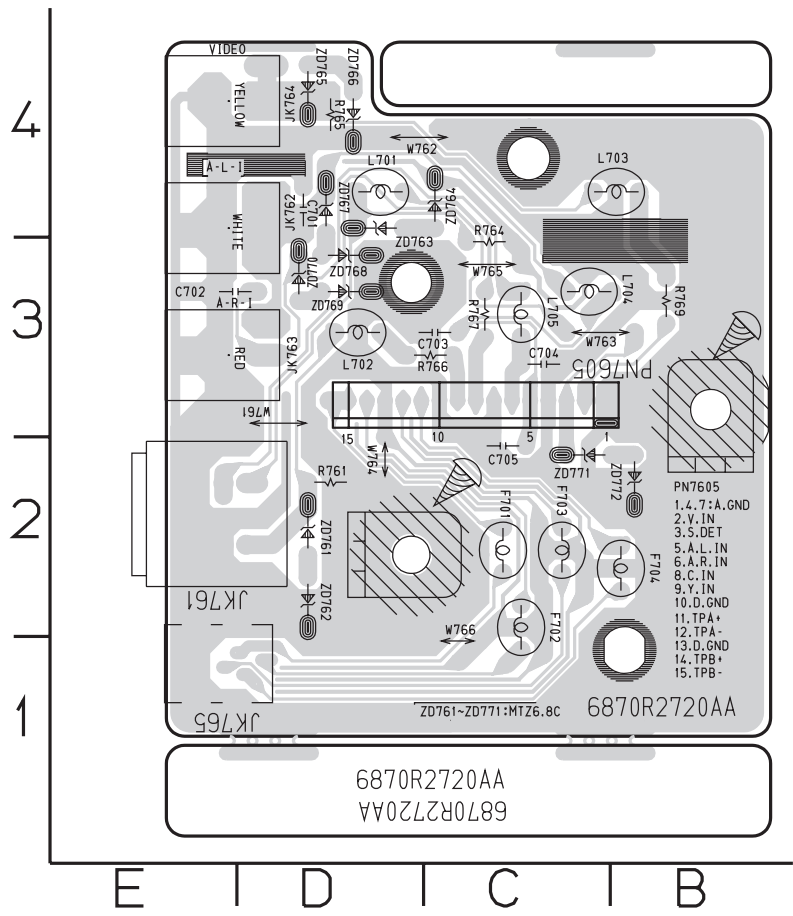

LOCATION GUIDE

C701	D4	ZD761	D2	L701	D4
C702	E3	ZD762	D2	L702	D3
C703	C3	ZD763	D4	L703	B4
C704	C3	ZD764	C4	L704	C3
C705	C2	ZD765	D4	L705	C3
F701	C2	ZD766	D4	PN7605	C3
F702	C2	ZD767	D4	R761	D2
F703	C2	ZD768	D3	R764	C3
F704	B2	ZD769	D3	R765	D4
JK761	E2	ZD770	D3	R766	C3
JK762	E4	ZD771	C2	R767	C3
JK763	E3	ZD772	B2	R769	B3
JK764	E4	C701	D4	ZD761	D2
JK765	D1	C702	E3	ZD762	D2
L701	D4	C703	C3	ZD763	D4
L702	D3	C704	C3	ZD764	C4
L703	B4	C705	C2	ZD765	D4
L704	C3	F701	C2	ZD766	D4
L705	C3	F702	C2	ZD767	D4
PN7605	C3	F703	C2	ZD768	D3
R761	D2	F704	B2	ZD769	D3
R764	C3	JK761	E2	ZD770	D3
R765	D4	JK762	E4	ZD771	C2
R766	C3	JK763	E3	ZD772	B2
R767	C3	JK764	E4		
R769	B3	JK765	D1		

5. KEY & TIMER P.C.BOARD

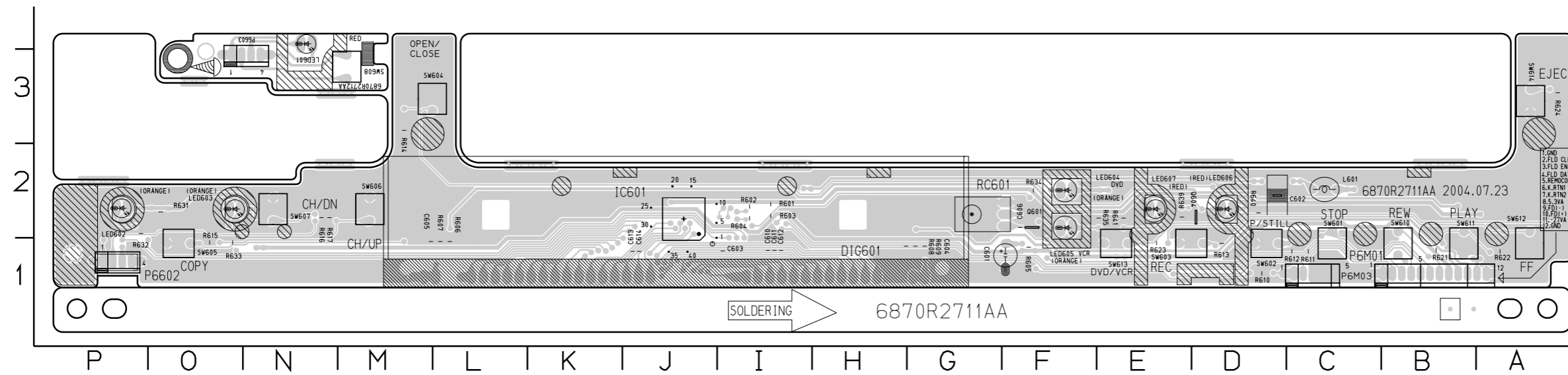

LOCATION GUIDE

C601	F1	P6M03	C1	R631	O2
C602	D2	Q601	F2	R632	P2
C603	I1	Q604	D2	R633	O1
C604	G1	R601	I2	R634	F2
C605	M1	R602	I2	R635	E2
C606	F2	R603	I2	R639	E2
C610	I1	R604	I2	R640	D2
C611	I1	R605	F1	R641	E2
C612	I1	R606	L1	RC601	G2
C613	J1	R607	L1	SW601	C1
C614	J1	R608	H1	SW602	D1
DIG601	M1	R609	G1	SW603	E1
IC601	J2	R610	D1	SW604	M3
L601	C2	R611	C1	SW605	O1
LED601	N4	R612	C1	SW606	M2
LED602	P2	R613	D1	SW607	N2
LED603	O2	R614	M3	SW608	M3
LED604	F2	R615	O1	SW610	B1
LED605	F2	R616	N2	SW611	B1
LED606	D2	R617	N2	SW612	A1
LED607	E2	R621	B1	SW613	E1
P6602	P1	R622	A1	SW614	A3
P6603	O3	R623	E1		
P6M01	B1	R624	A3		

VDR PART

VDR ELECTRICAL TROUBLESHOOTING GUIDE

1. Power(SMPS) CIRCUIT

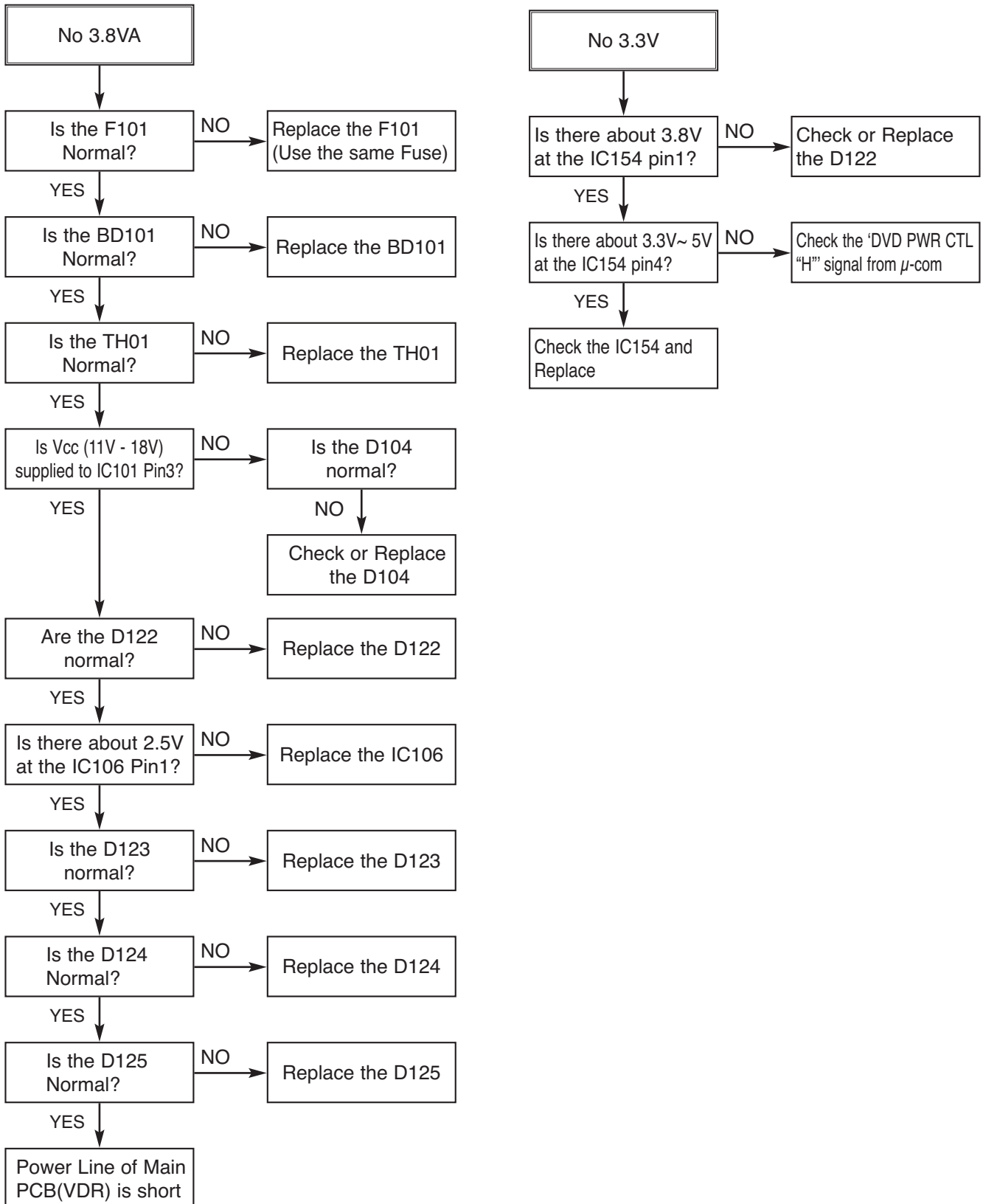

VDR ELECTRICAL TROUBLESHOOTING GUIDE

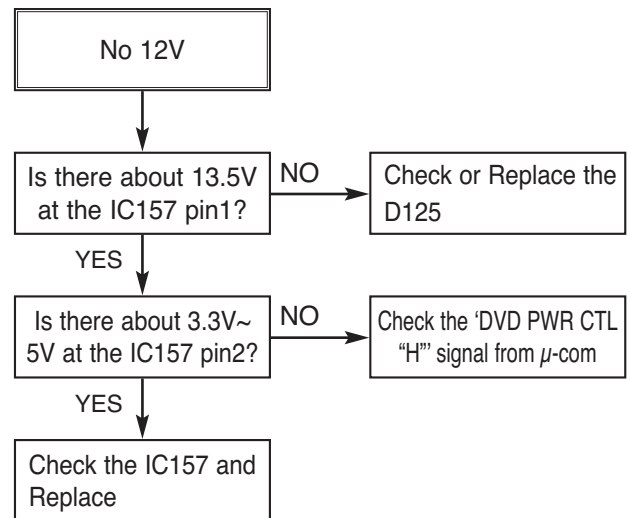
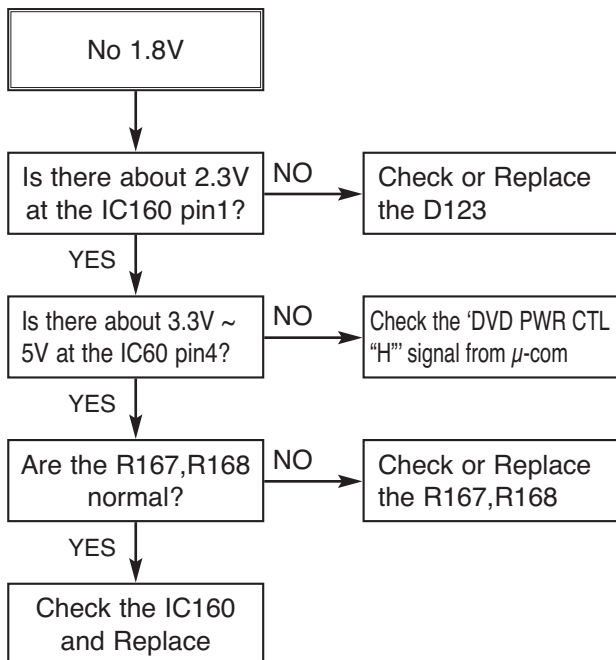
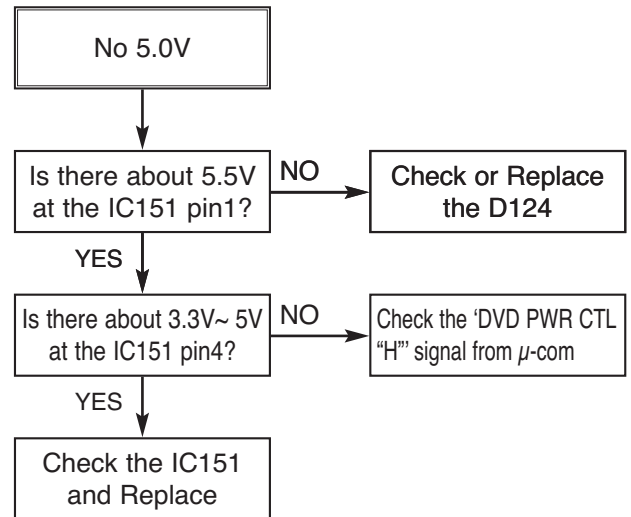
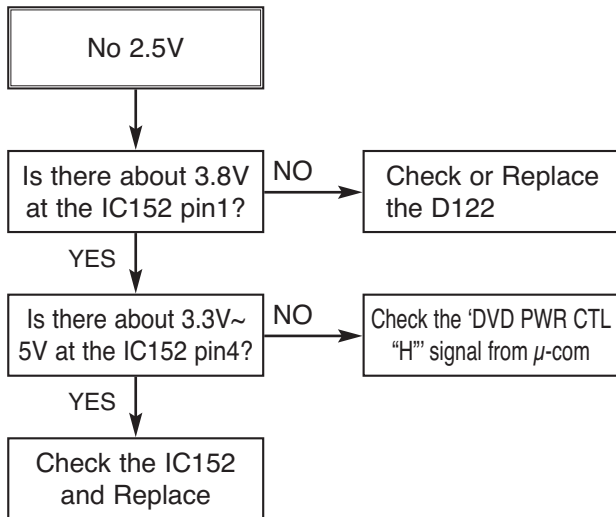

VDR ELECTRICAL TROUBLESHOOTING GUIDE

2. No Component video signal when playing DISC

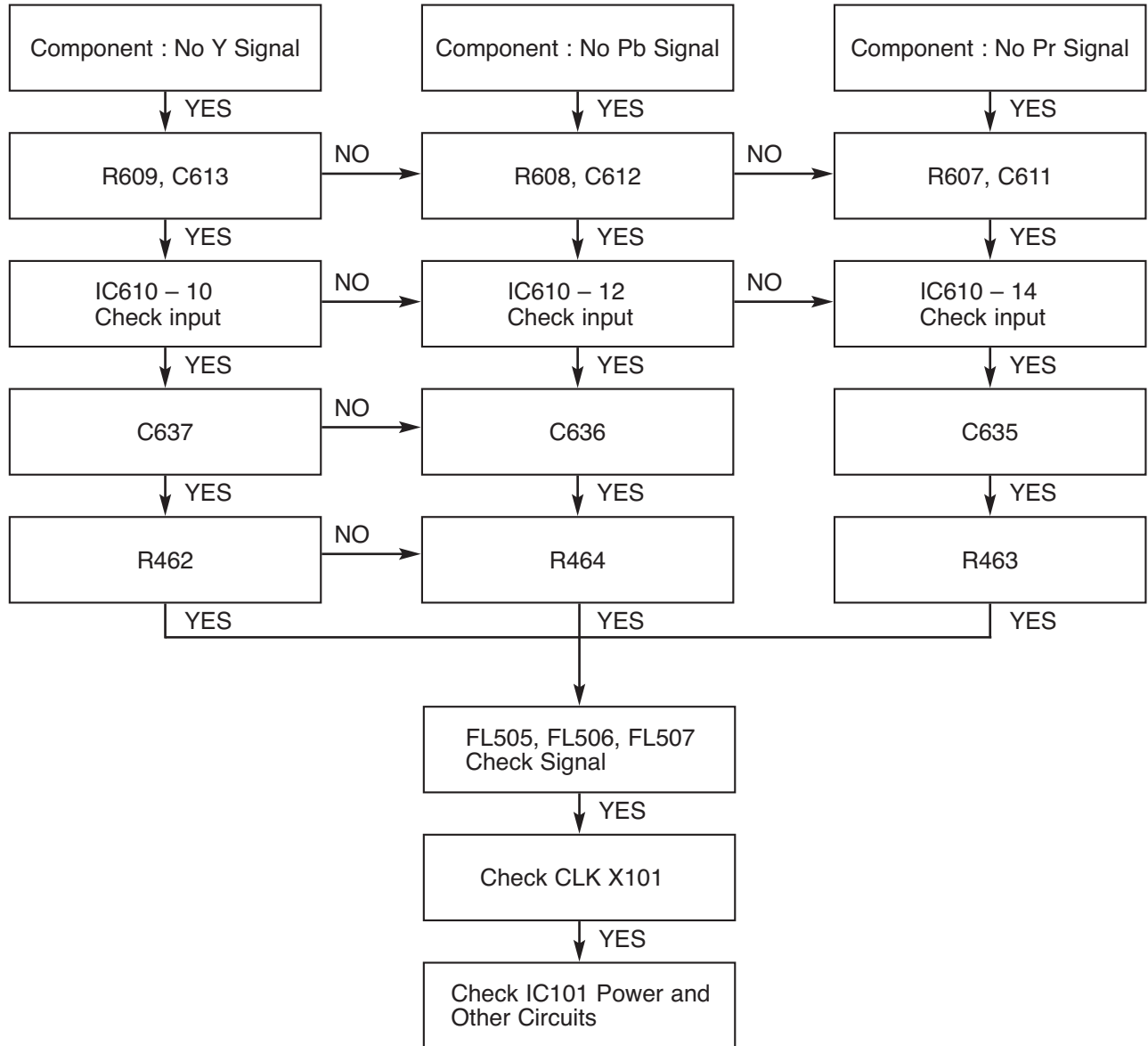

VDR ELECTRICAL TROUBLESHOOTING GUIDE

3. No COMPOSITE / S-VIDEO signal when playing DISC

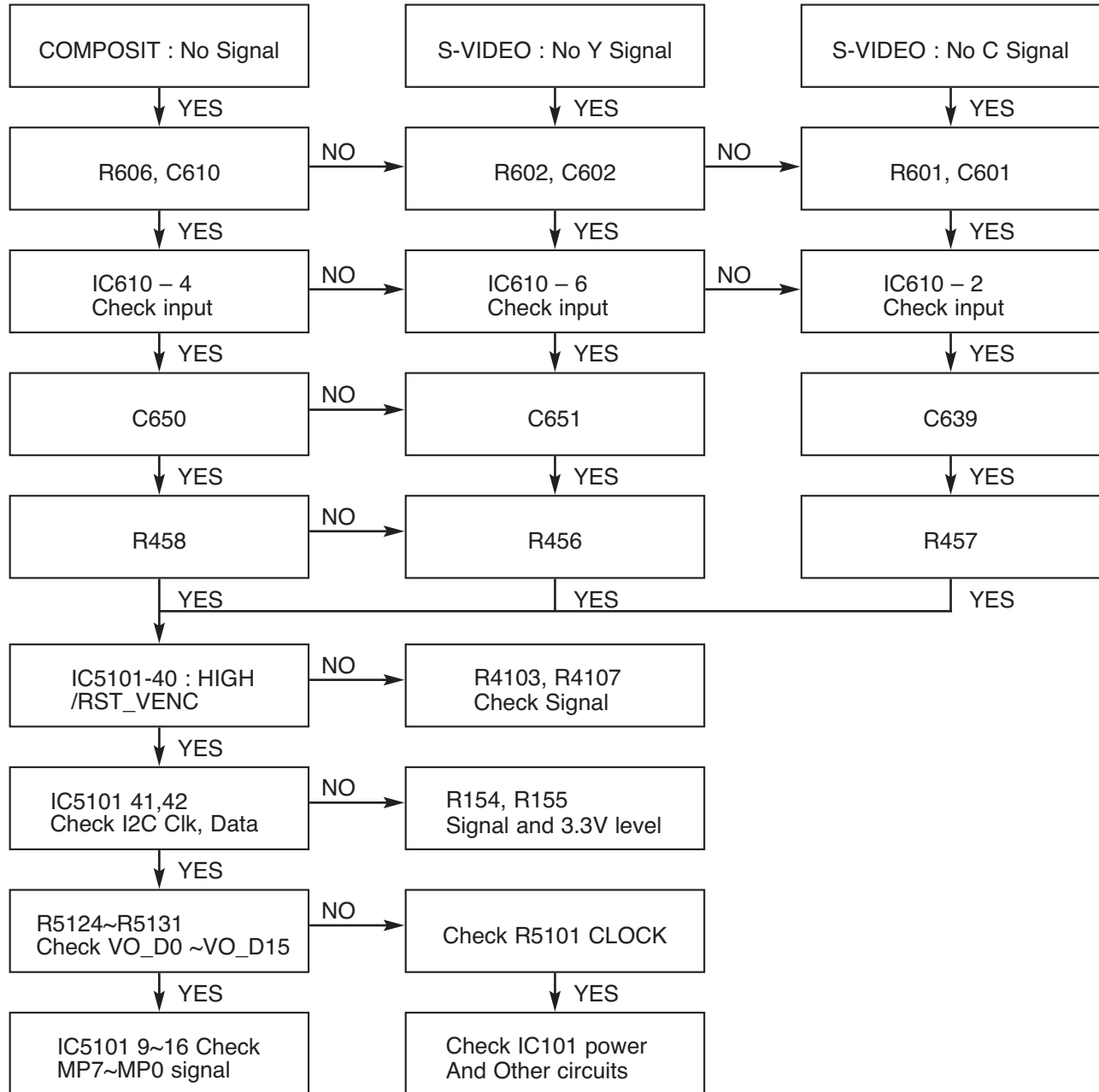

VDR ELECTRICAL TROUBLESHOOTING GUIDE

4. No TV, External Input video signal

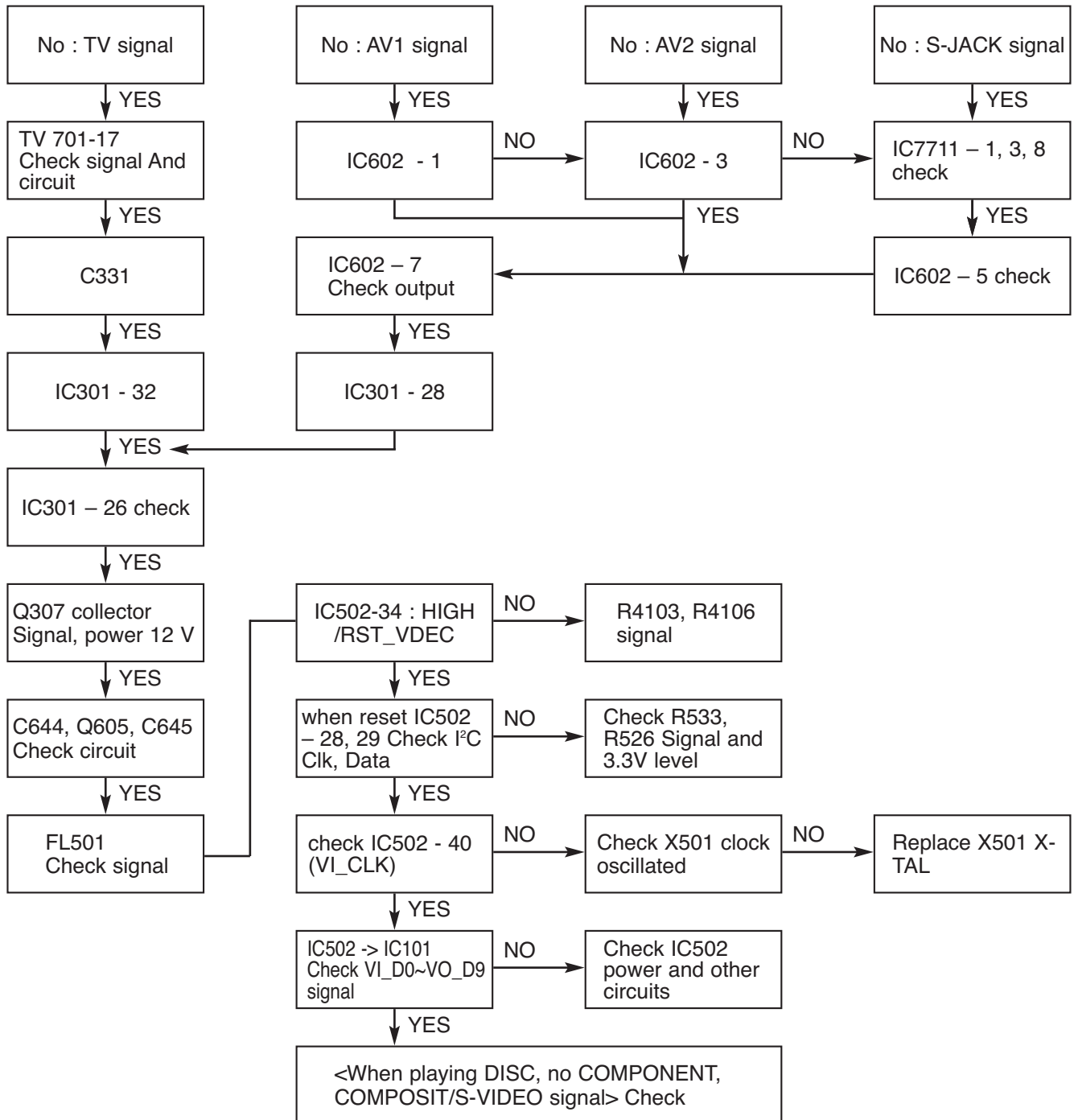

VDR ELECTRICAL TROUBLESHOOTING GUIDE

5. When playing DISC, no audio output

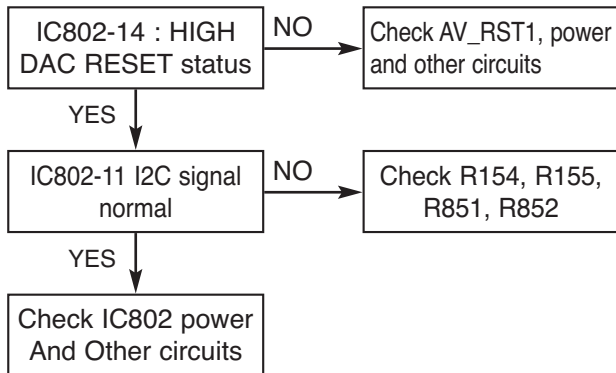

7. No OPTICAL / DIGITAL output

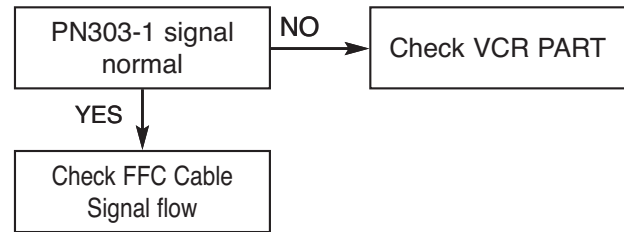

6. No TUNER audio output

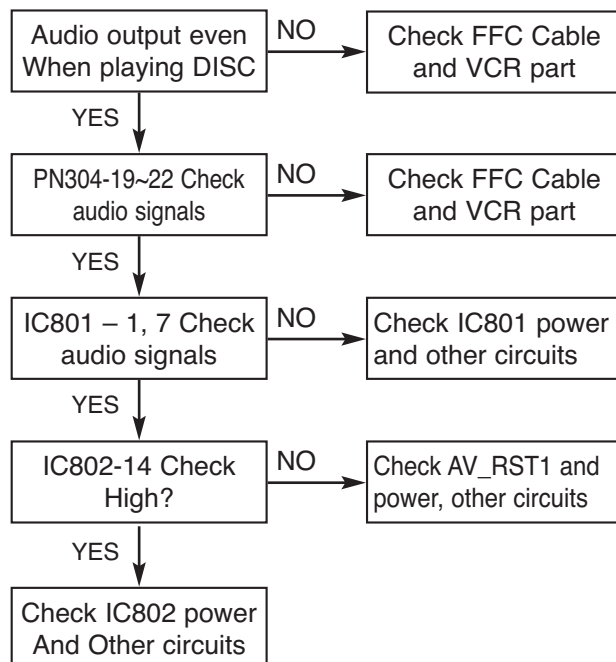

VDR ELECTRICAL TROUBLESHOOTING GUIDE

8. No External Input 1 audio

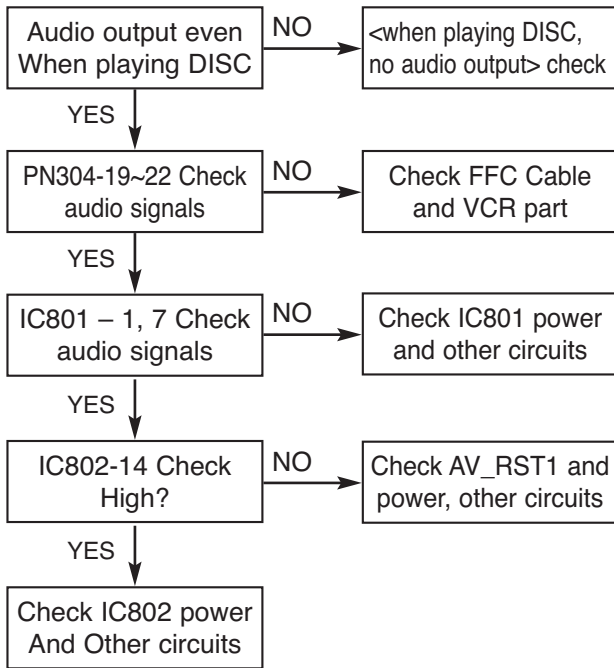

9. No External Input 2 audio

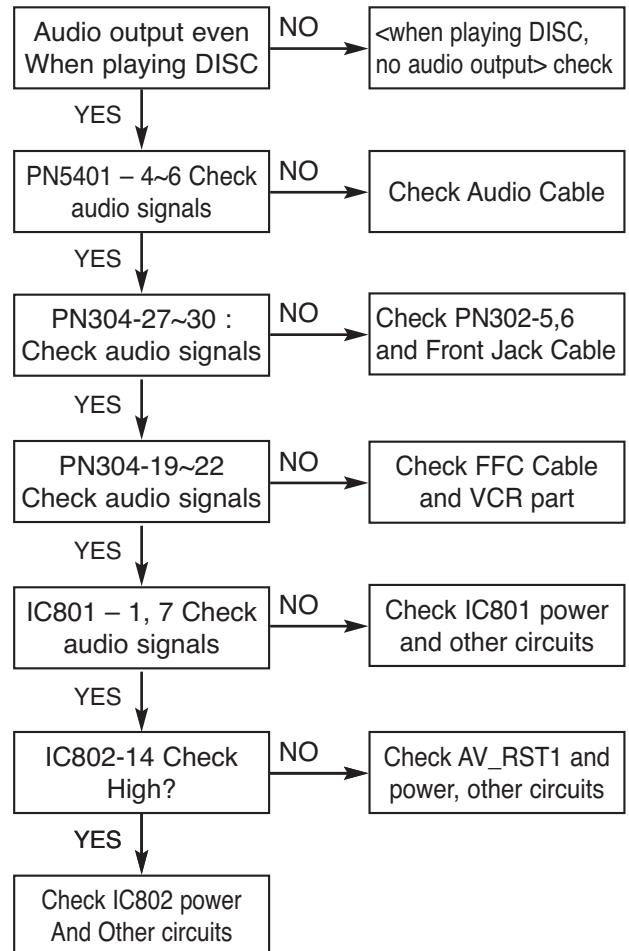

BLOCK DIAGRAMS

1. VDR MAIN H/ W BLOCK DIAGRAM

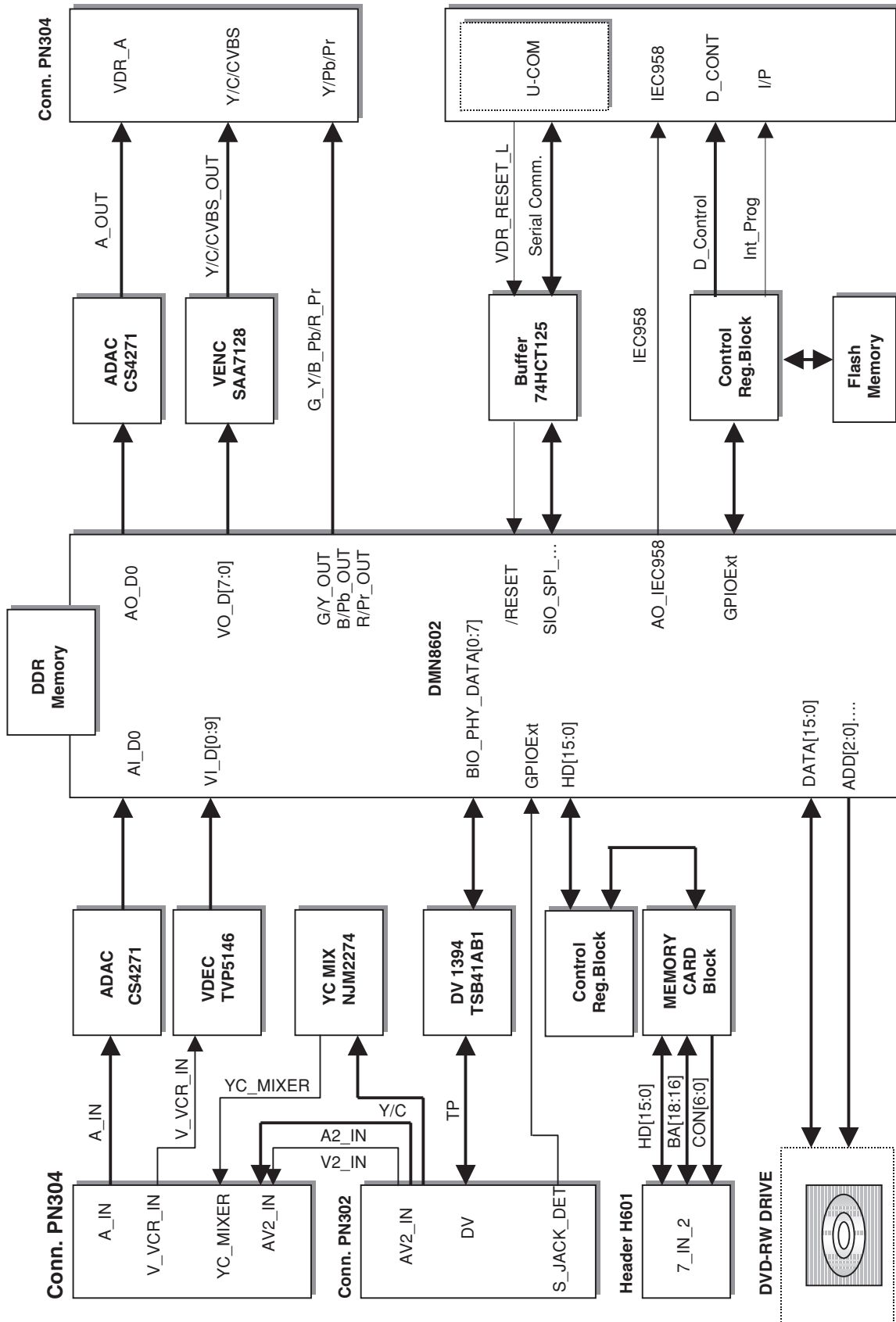

2. POWER BLOCK DIAGRAM

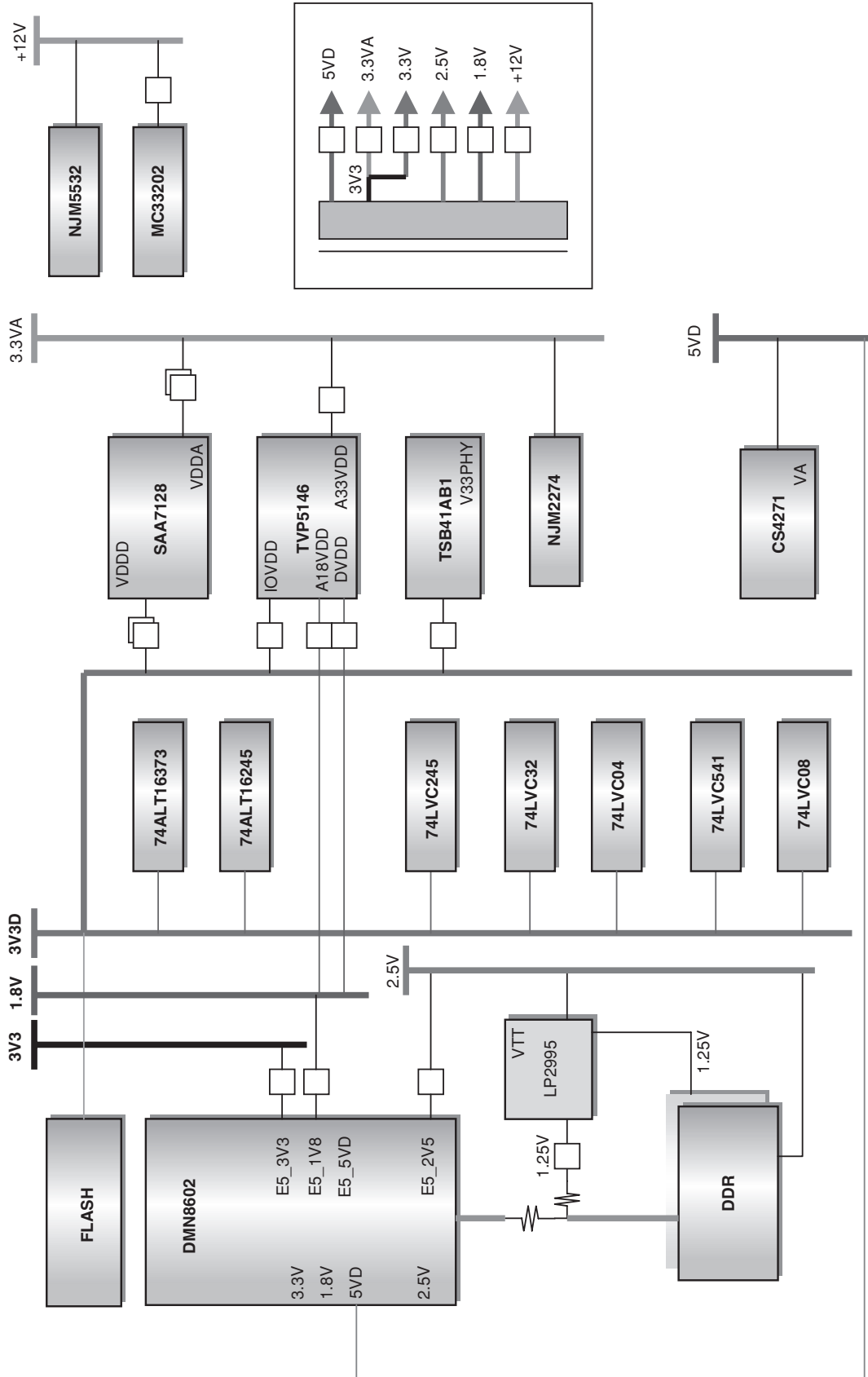

3. AUDIO IN/ OUT BLOCK DIAGRAM

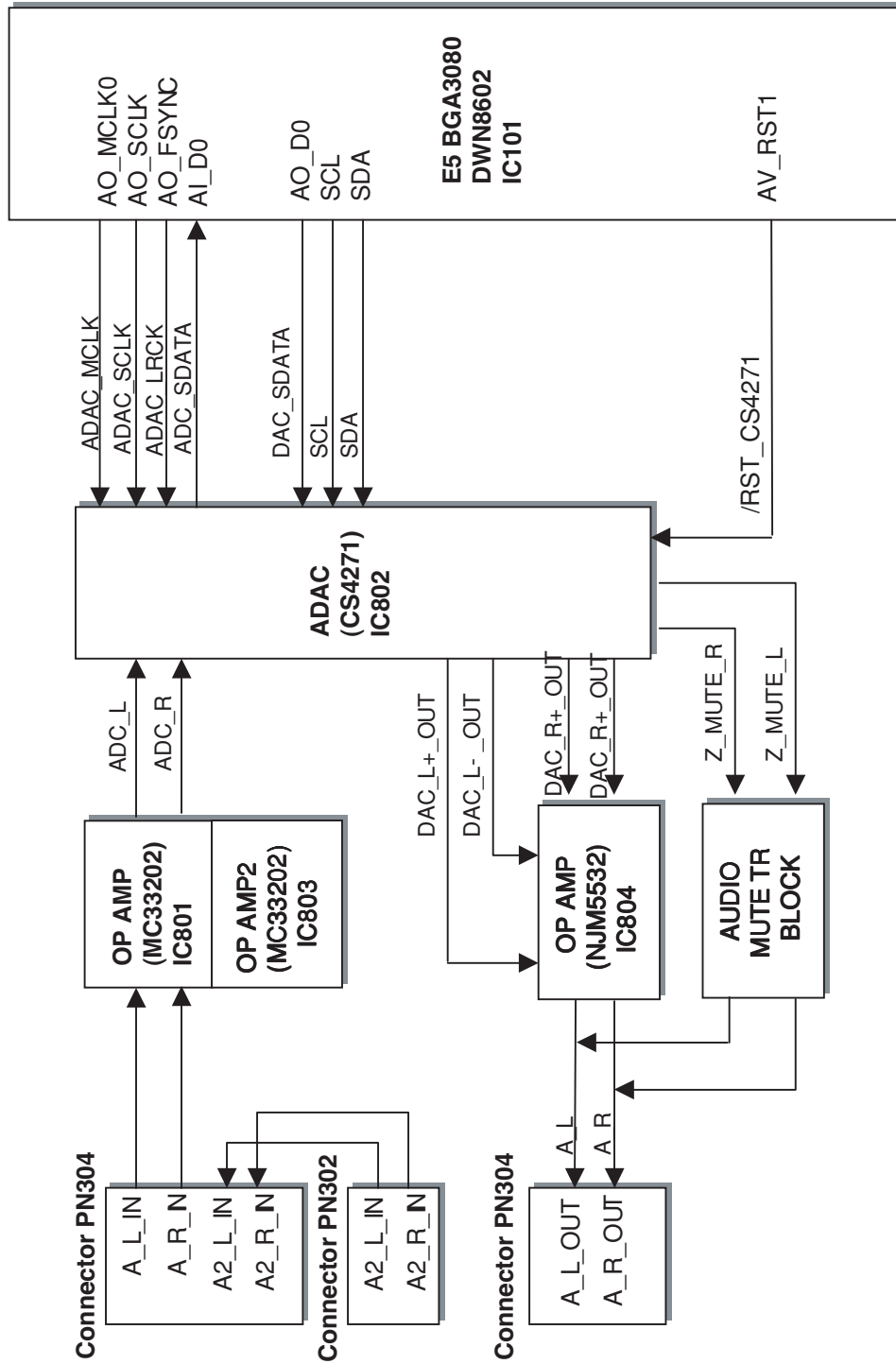

4. CPU & CONTROL REGISTER BLOCK DIAGRAM

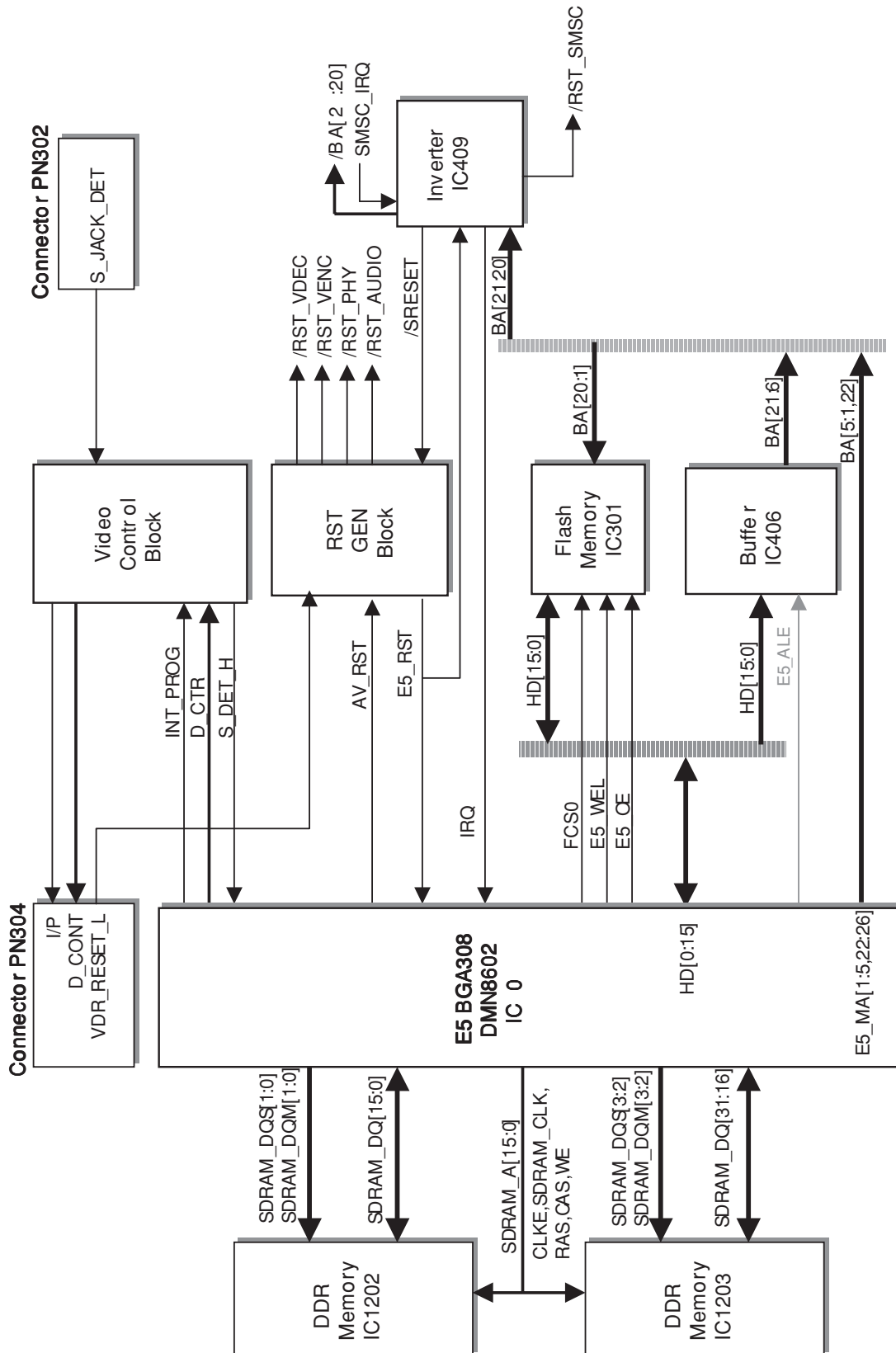

5. VIDEO IN/ OUT BLOCK DIAGRAM

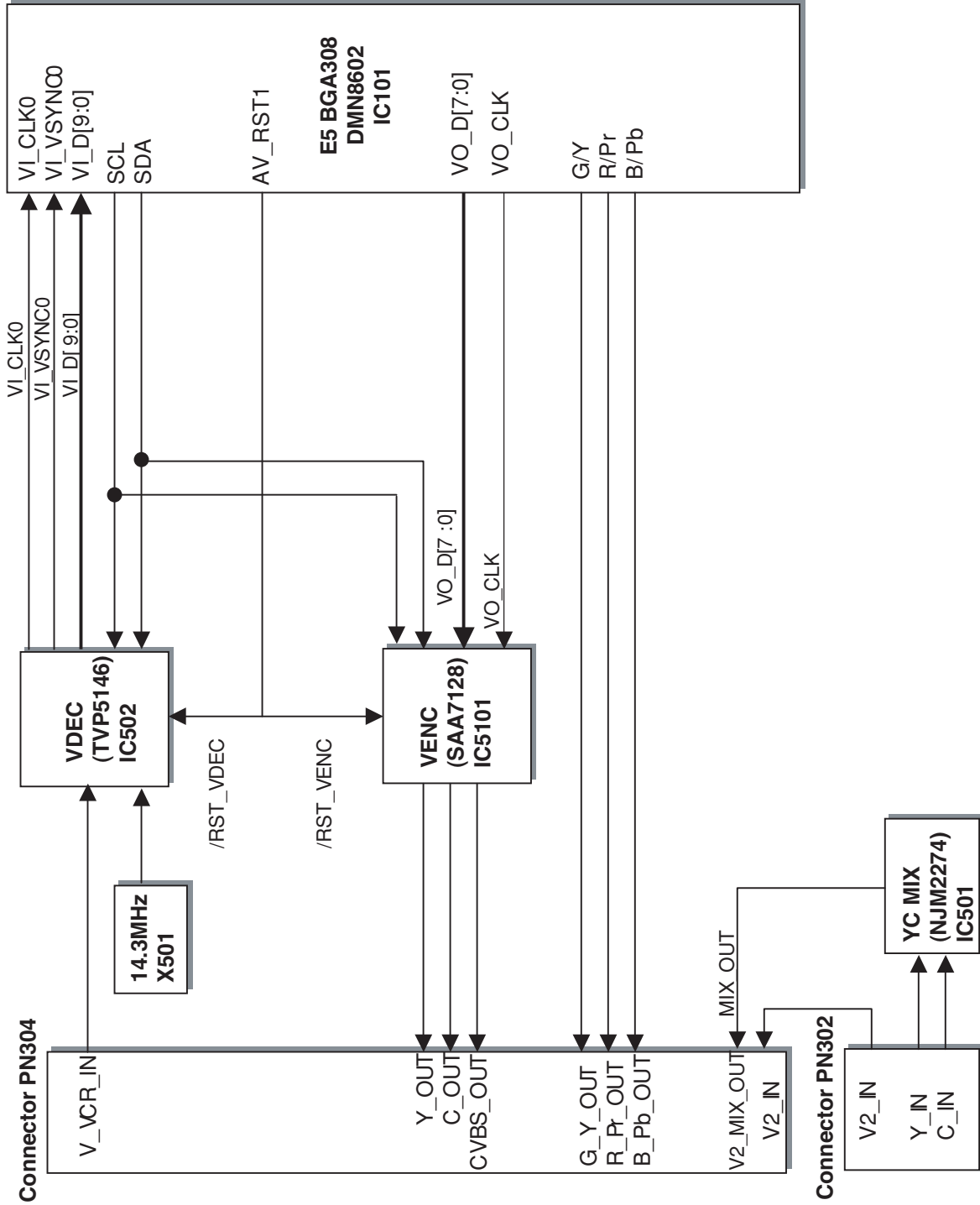

6. DV 1394 IN/OUT BLOCK DIAGRAM

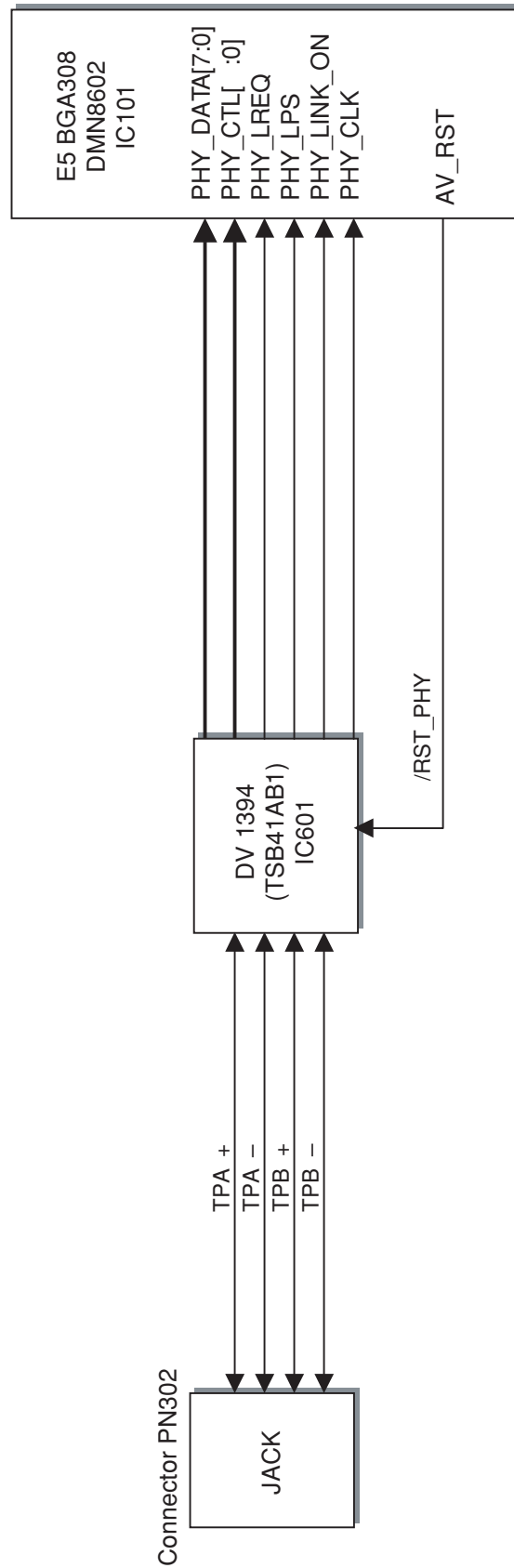

7. MEMORY CARD IN/ OUT BLOCK DIAGRAM

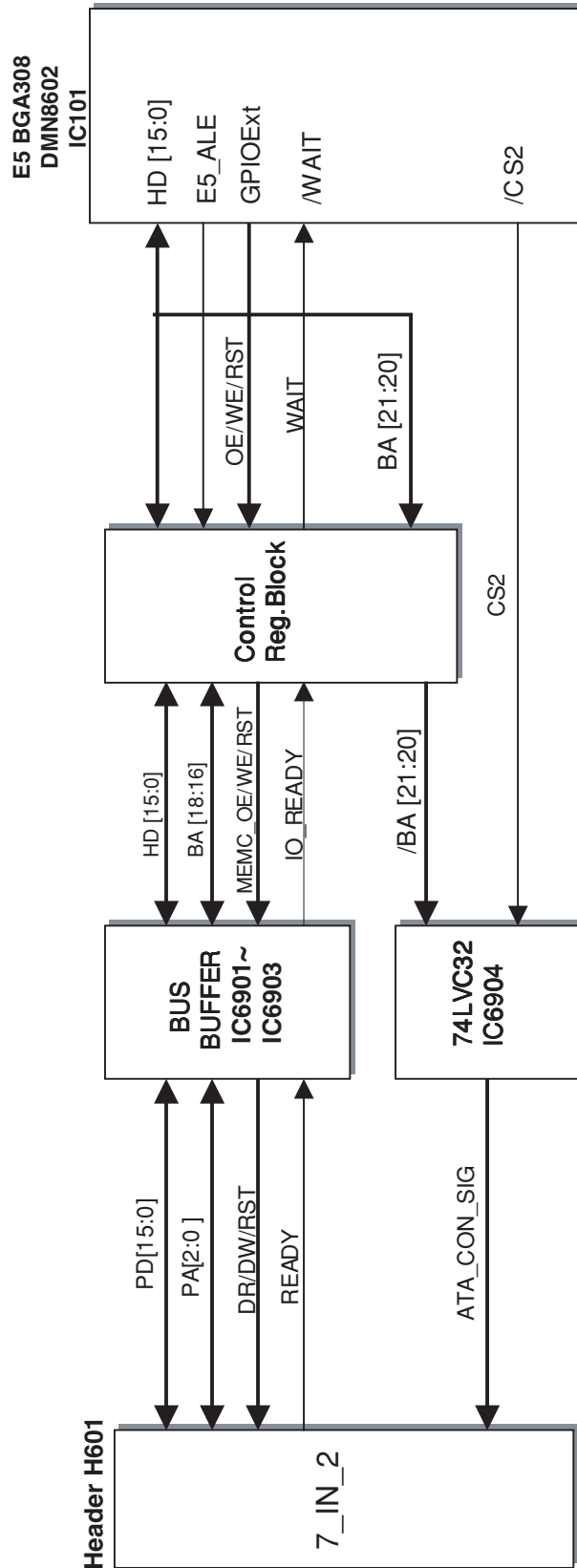

CIRCUIT DIAGRAMS

1. BGA 308P CIRCUIT DIAGRAM

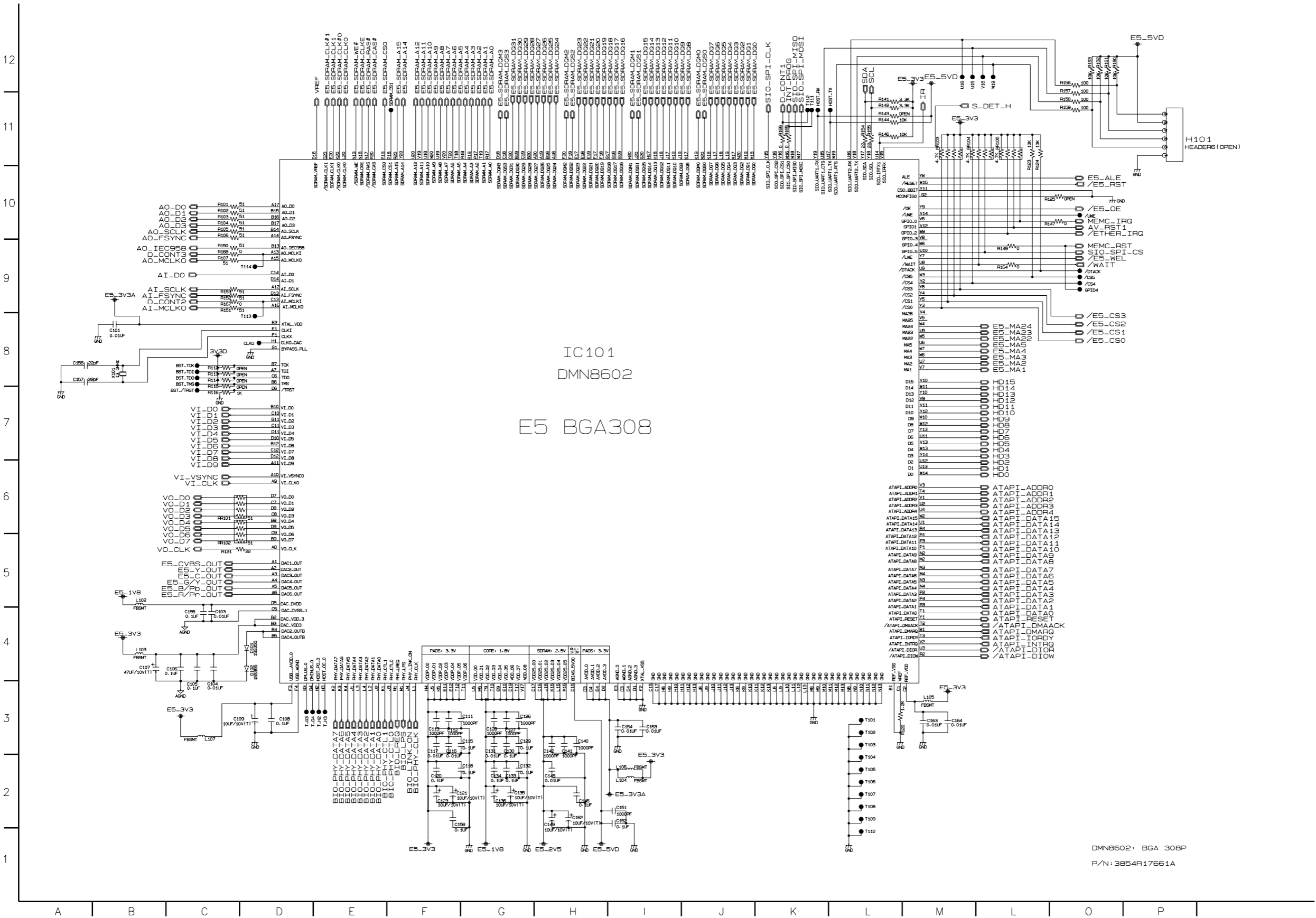

DMN8602: BGA 308P
P/N: 3854R17661A

2. DDR & B TO B CONNECTOR CIRCUIT DIAGRAM

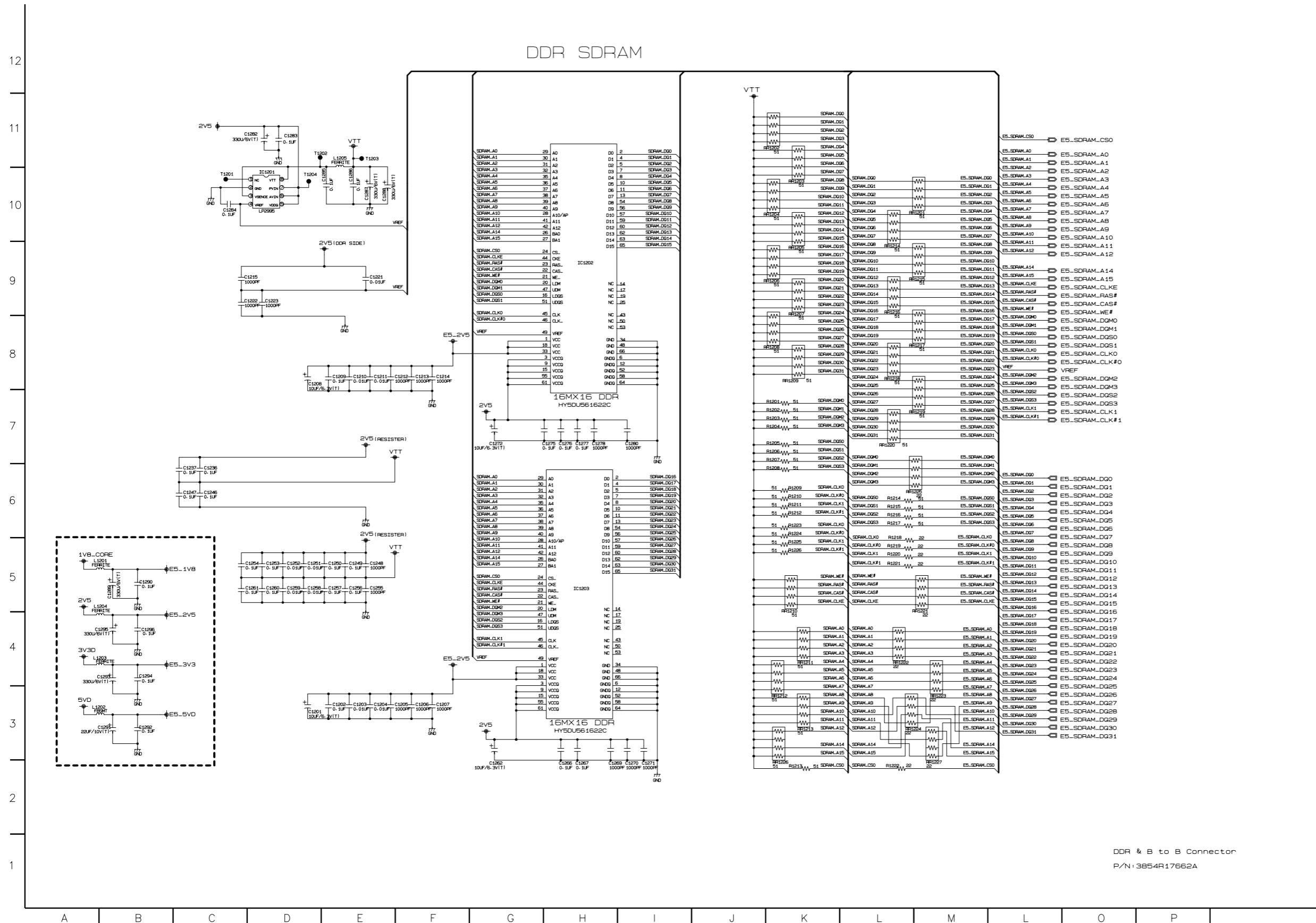

DDR & B to B Connector
P/N: 3854R17662A

3. POWER, FLASH, CONNECTOR CIRCUIT DIAGRAM

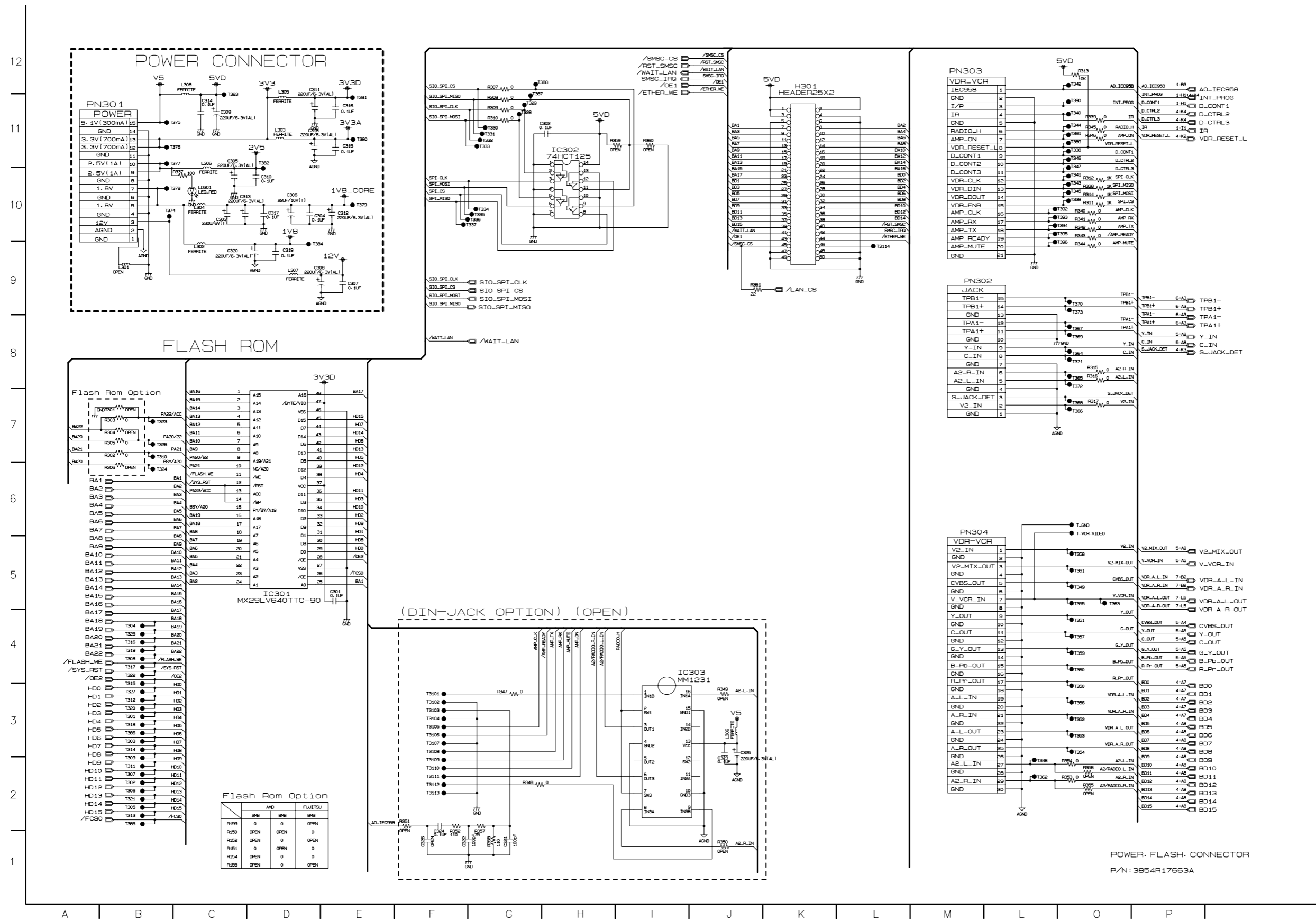

4. RST, CONTROL/STATUS_REG., ATAPI, HOST_CPLD, LATCH CIRCUIT DIAGRAM

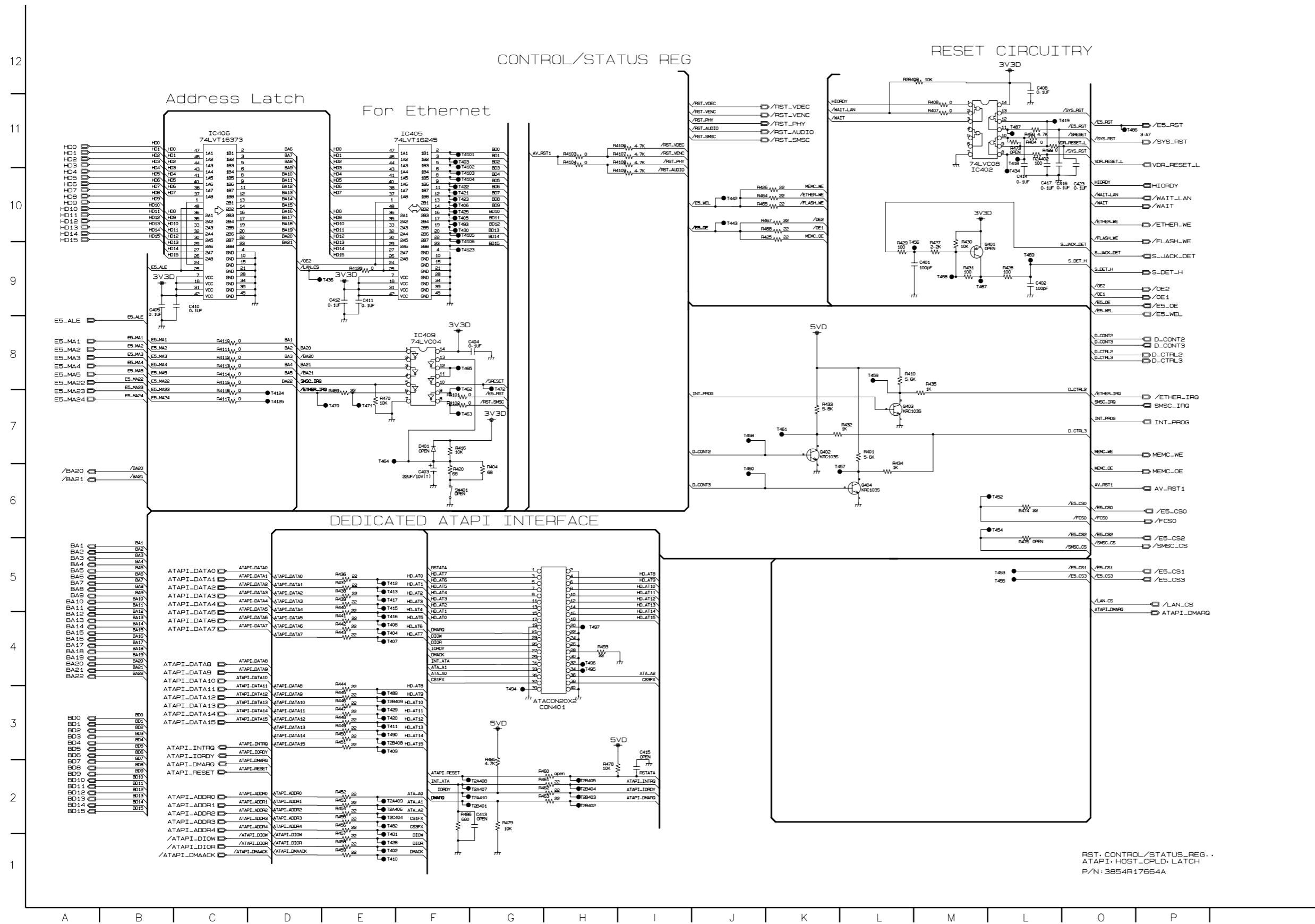

RST, CONTROL/STATUS_REG.,
ATAPI, HOST_CPLD, LATCH
P/N: 3854R17664A

5. VIDEO_IN, VIDEO_OUT CIRCUIT DIAGRAM

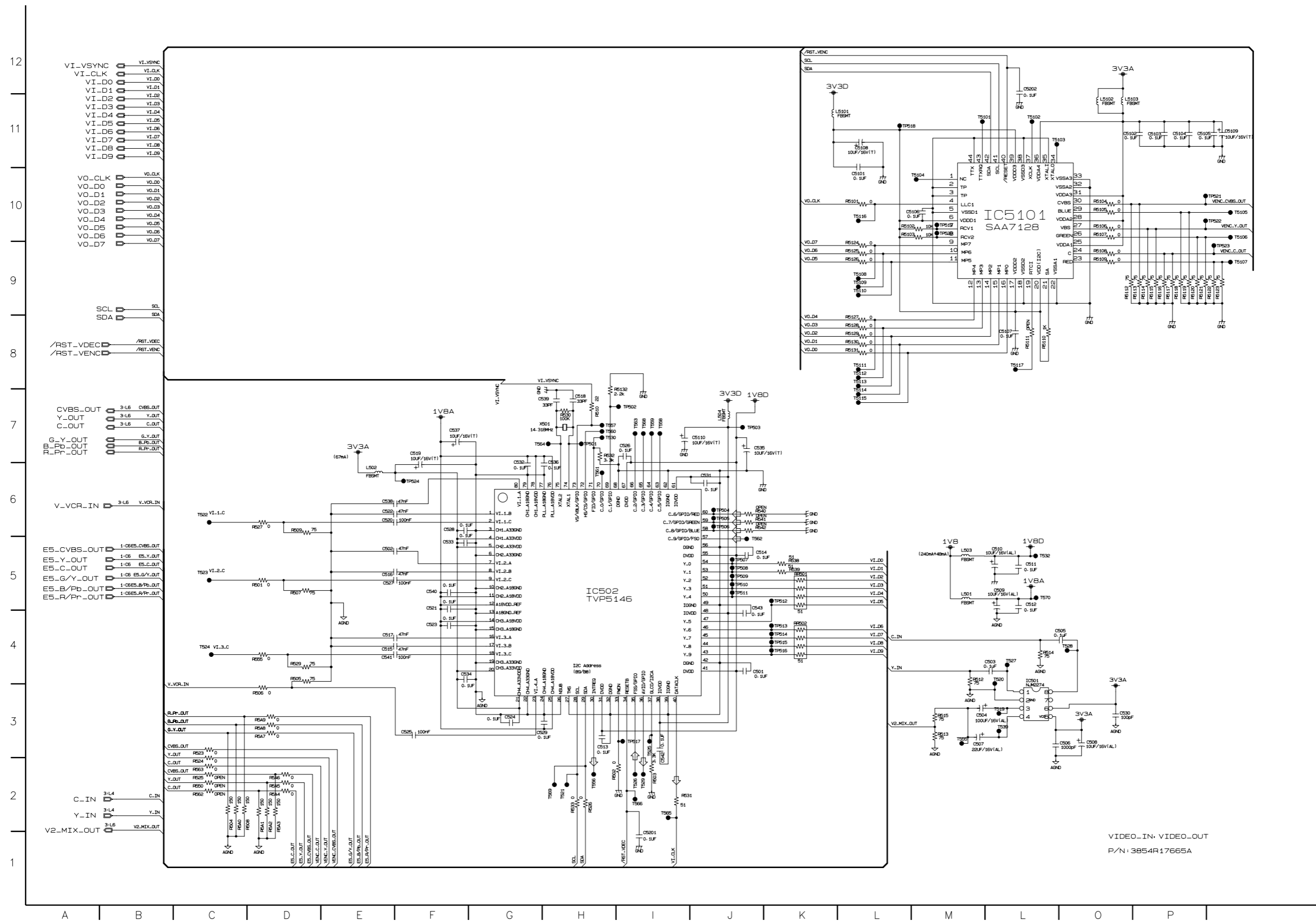

6. DV1394, HDMI CIRCUIT DIAGRAM

12
11
10
9
8
7
6
5
4
3
2
1

- BIO_PHY_CTL0 ↔ BIO_PHY_CTL0
- BIO_PHY_CTL1 ↔ BIO_PHY_CTL1
- BIO_PHY_DATA0 ↔ BIO_PHY_DATA0
- BIO_PHY_DATA1 ↔ BIO_PHY_DATA1
- BIO_PHY_DATA2 ↔ BIO_PHY_DATA2
- BIO_PHY_DATA3 ↔ BIO_PHY_DATA3
- BIO_PHY_DATA4 ↔ BIO_PHY_DATA4
- BIO_PHY_DATA5 ↔ BIO_PHY_DATA5
- BIO_PHY_DATA6 ↔ BIO_PHY_DATA6
- BIO_PHY_DATA7 ↔ BIO_PHY_DATA7
- BIO_PHY_CLK ↔ BIO_PHY_CLK

- BIO_LPS ↔ BIO_LPS
- BIO_LREQ ↔ BIO_LREQ

- BIO_LINK_ON ↔ BIO_LINK_ON
- /RST_PHY ↔ /RST_PHY

- TPA1+ ↔ TPA1+
- TPA1- ↔ TPA1-
- TPB1+ ↔ TPB1+
- TPB1- ↔ TPB1-

[For 7-in-1]

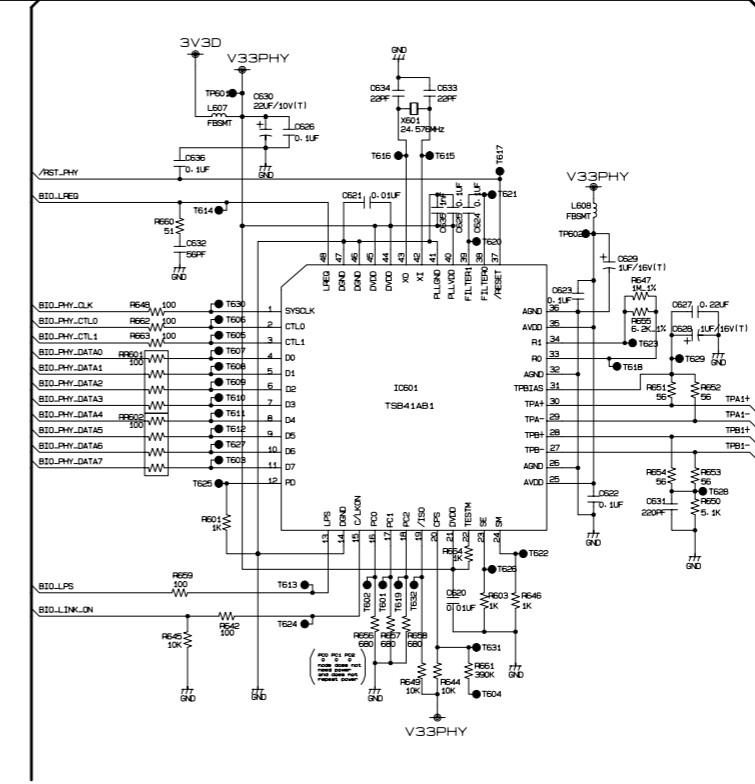
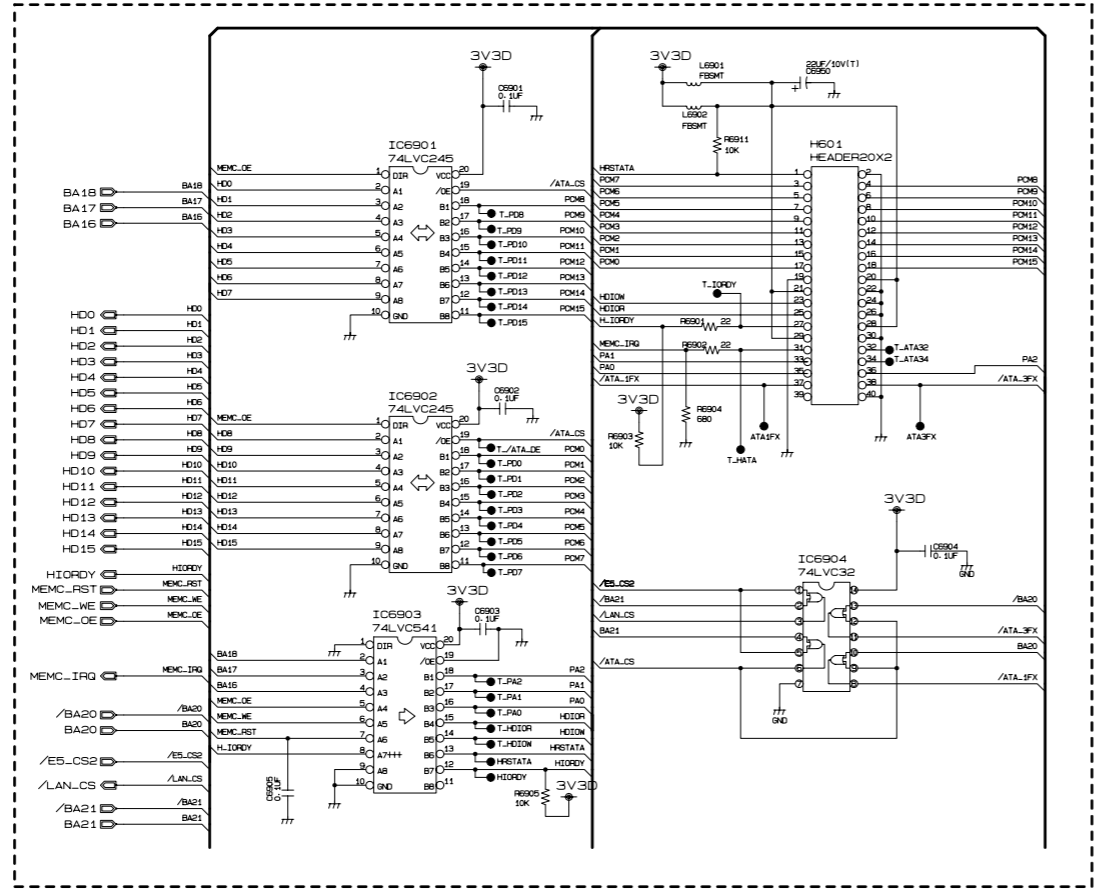

DV1394, HDMI (Option)
P/N: 3854R17666A

A B C D E F G H I J K L M N O P

7. AUDIO IN/OUT CIRCUIT DIAGRAM

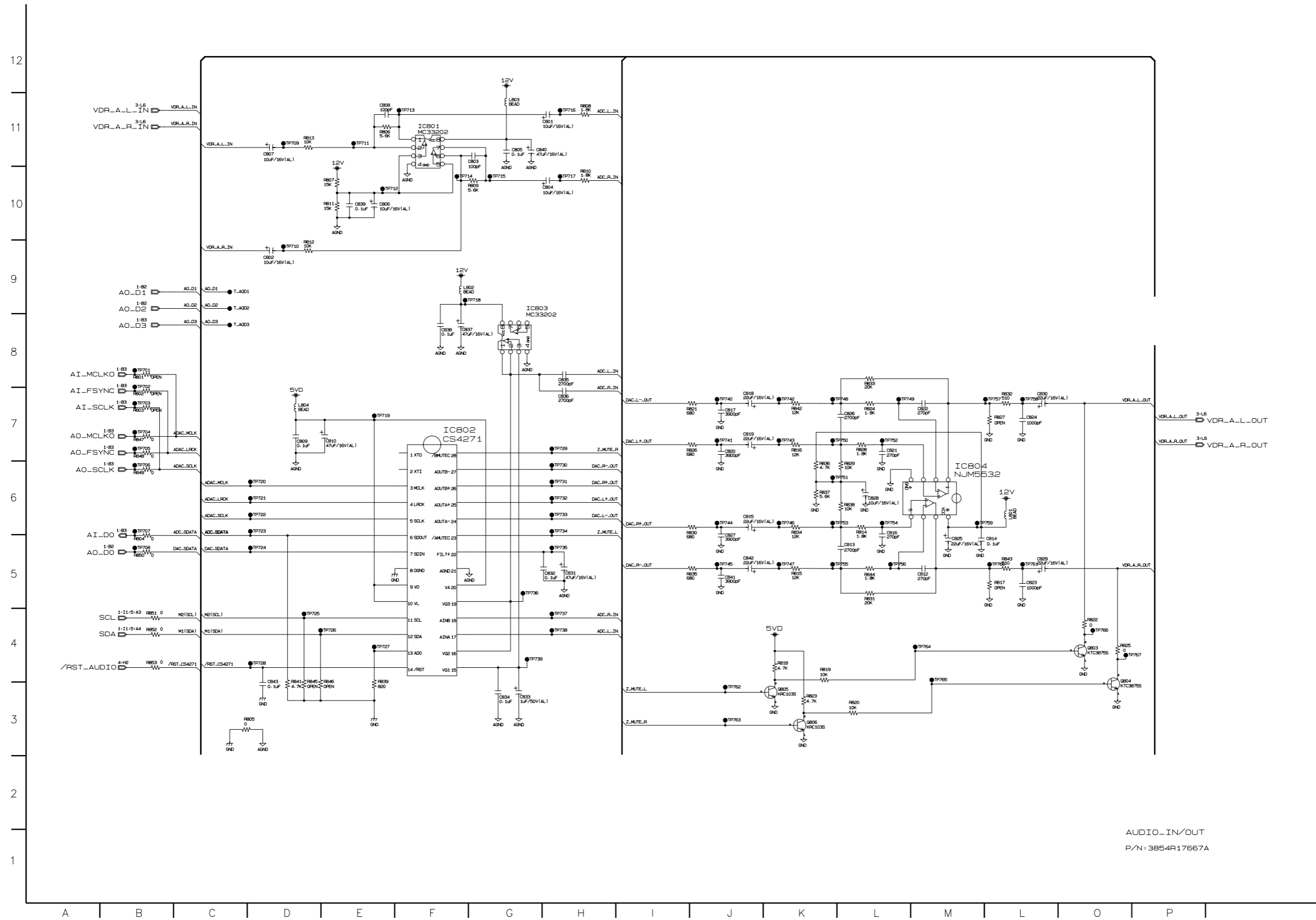

AUDIO_IN/OUT
P/N: 3854R17667A

• WAVEFORMS

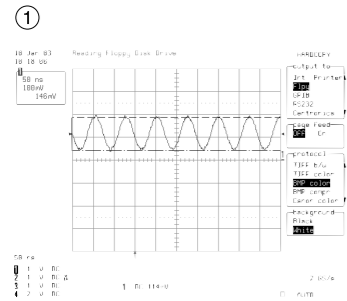

①
X101
13.5MHz

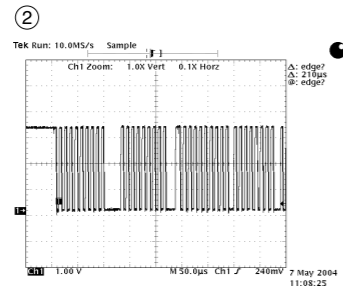

②
IC4009
PIN32
SDA

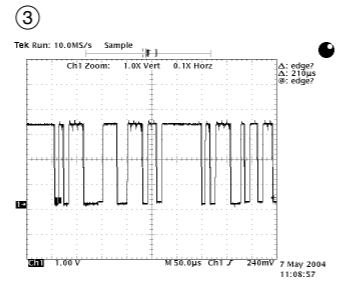

③
IC502
PIN29
SDA

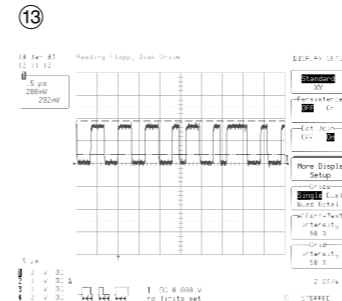

⑬
PN303
PIN1
IEC958

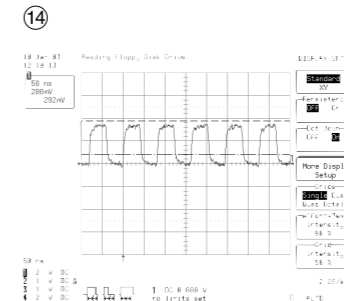

⑭
IC802
PIN3
ADAC_MCLK

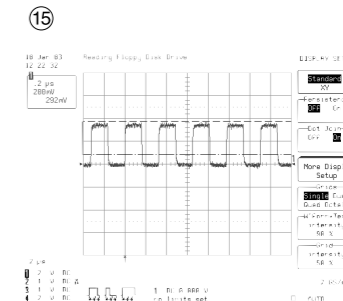

⑮
IC802
PIN5
ADAC_SCLK

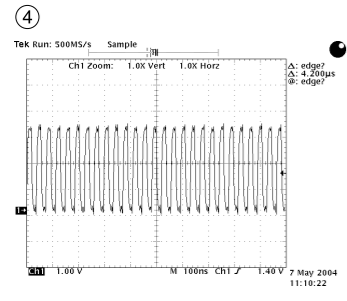

④
IC502
PIN40
VI_CLK

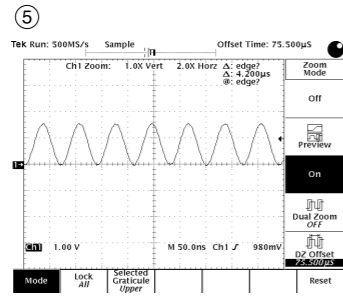

⑤
IC502
PIN74
14.318MHz

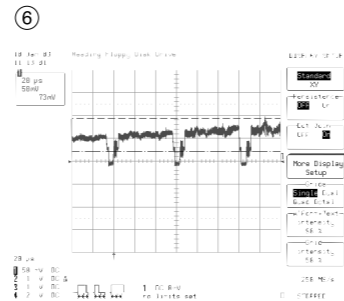

⑥
PN304
PIN5
CVBS_OUT

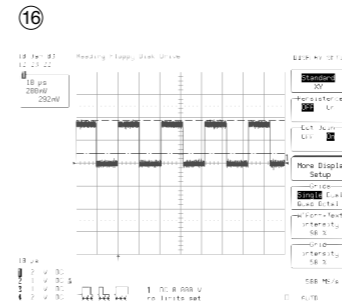

⑯
IC802
PIN4
ADAC_LRCK

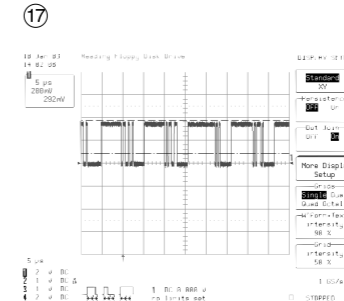

⑰
IC802
PIN6
ADC_SDATA(AI_D0)

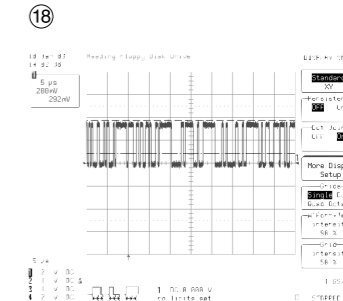

⑱
IC802
PIN7
DAC_SDATA(AO_D0)

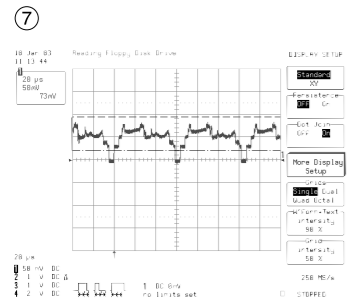

⑦
PN304
PIN9
Y_OUT

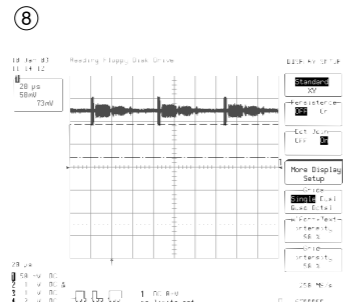

⑧
PN304
PIN11
C_OUT

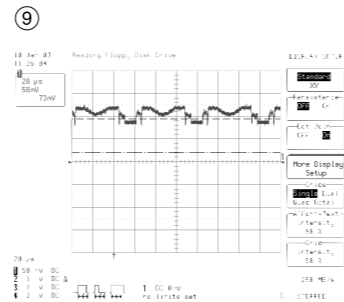

⑨
PN304
PIN17
R_Pr_OUT

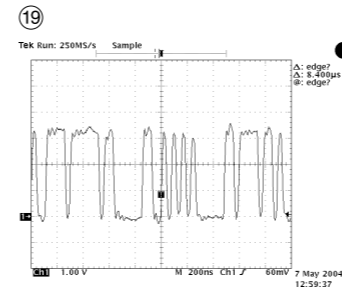

⑲
IC502
PIN53
VI_D1

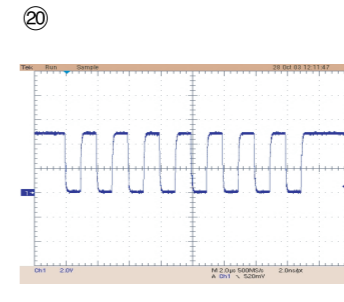

⑳
PN7401
PIN 12
VDR_CLK

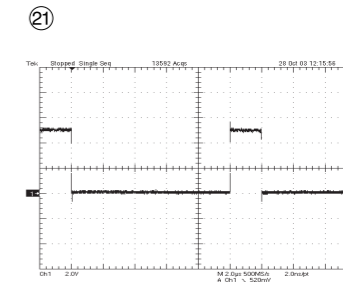

㉑
PN7401
PIN 13
VDR_DIN

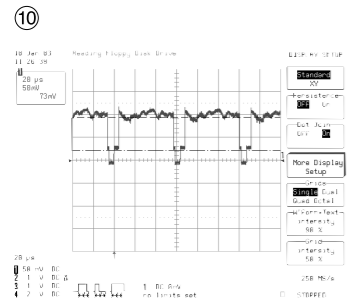

⑩
PN304
PIN13
G_Y_OUT

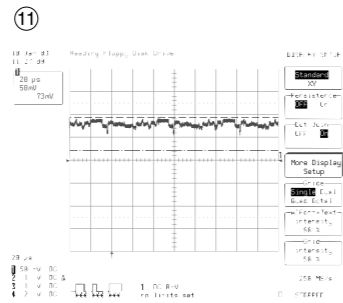

⑪
PN304
PIN15
B_Pb_OUT

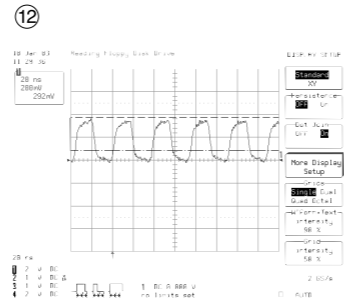

⑫
IC5101
PIN4
VO_CLK

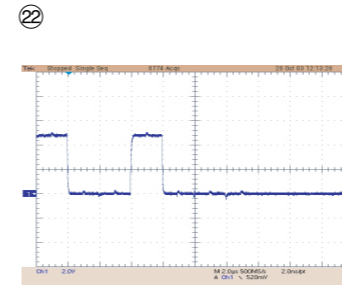

㉒
PN7401
PIN 14
VDR_DOUT

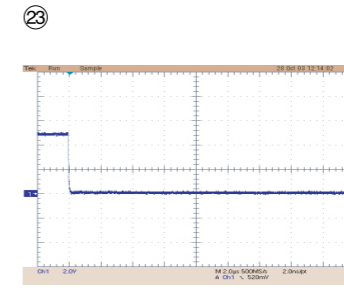

㉓
PN7401
PIN 15
VDR_ENB

• CIRCUIT VOLTAGE CHART

MODE PIN NO.	EE	PB	REC
IC 1201			
1	0	0	0
2	0	0	0
3	1.23	1.23	1.23
4	1.23	1.23	1.23
5	2.48	2.48	2.47
6	2.48	2.48	2.47
7	2.48	2.48	2.47
8	1.23	1.23	1.22
IC 302			
1	0	0	0
2	3.28	3.29	3.27
3	4.96	4.96	4.96
4	0	0	0
5	0	0	0
6	0	0.01	0.01
7	0	0	0
8	3.98	3.97	3.97
9	2.64	2.64	2.64
10	0	0	0
11	4.21	4.2	4.2
12	4.32	4.3	4.3
13	0	0	0
14	4.97	4.97	4.97
IC 402			
1	3.29	3.29	3.29
2	3.32	3.32	3.32
3	3.29	3.29	3.29
4	0.04	0.04	0
5	0	0.04	0
6	0	0	0
7	0	0	0
8	3.29	3.29	3.29
9	5.09	5.09	5.9
10	3.29	3.29	3.29
11	3.29	3.29	3.29
12	5.09	5.09	5.09
13	3.29	3.29	3.29
14	3.29	3.29	3.29
IC 405			
1	3.28	3.28	3.29
2	3.31	0.19	0.19
3	3.22	0.19	0.19
4	0	0	0
5	0.19	0.19	0.19
6	0.19	0.19	0.19
7	3.29	3.29	3.29
8	0.19	0.19	0.19
9	0.19	0.19	0.19
10	0	0	0
11	0.19	0.19	0.19
12	0.19	0.19	0.19
13	0.19	0.19	0.19
14	3.31	0.19	0.19
15	0	0	0

MODE PIN NO.	EE	PB	REC
16	0.19	0.19	0.19
17	0.19	0.19	0.19
18	3.29	3.29	3.29
19	0.19	0.19	0.19
20	0	0.19	0.19
21	0	0	0
22	0.19	0.19	0.19
23	0	0.19	0.19
24	3.28	3.29	3.29
25	3.29	3.29	3.29
26	0	0	0
27	0	0	0
28	0	0	0
29	0	0	0
30	0	0	0
31	3.29	3.29	3.29
32	0	0	0
33	0	0	0
34	0	0	0
35	0	0	0
36	0	0	0
37	0	0	0
38	0	0	0
39	0	0	0
40	0	0	0
41	0	0	0
42	3.29	3.28	3.29
43	0	0	0
44	0	0	0
45	0	0	0
46	0	2.92	0
47	0	2.92	0
48	3.29	3.29	3.29
IC 406			
1	0	0	0
2	0.04	0.04	0.04
3	0.04	0.04	0.04
4	0	0	0
5	3.29	3.29	3.29
6	3.29	3.29	3.29
7	3.29	3.29	3.29
8	0.04	0.04	0.04
9	0.04	0.04	0.04
10	0	0	0
11	0.04	0.04	0.04
12	0.04	0.04	0.04
13	0.04	0.04	0.04
14	0.04	0.04	0.04
15	0	0	0
16	0.04	0.04	0.04
17	0.04	0.04	0.04
18	3.29	3.29	3.29
19	0.04	0.04	0.04
20	0.04	0.04	0.04
21	0	0	0

MODE PIN NO.	EE	PB	REC
22	0.04	0.04	0.04
23	3.29	3.29	3.29
24	0	0	0
25	0.01	0.01	0.01
26	0	0	0
270	0	0	0
28	0	0	0
29	0	0	0
30	0	0	0
31	3.29	3.29	3.29
32	0	0	0
33	0	0	0
34	0	0	0
35	0	0	0
36	0	0	0
37	0	0	0
38	0	0	0
39	0	0	0
40	0	0	0
41	0	0	0
42	3.29	3.29	3.29
43	0	0	0
44	0	0	0
45	0	0	0
46	0	0	0
47	0	0	0
48	0	0	0.01
IC 502			
1	0.00	0.001	0.001
2	0.00	0.002	0.004
3	0.00	0	0
4	3.26	3.256	3.255
5	3.26	3.256	3.255
6	0.00	0	0
7	0.15	0.002	0.002
8	0.00	0.001	0.002
9	0.00	0.001	0.002
10	0.00	0	0
11	1.86	1.854	1.851
12	1.86	1.854	1.851
13	0.00	0	0
14	1.86	1.854	1.851
15	0.00	0	0
16	0.00	0.002	0.002
17	0.00	0.001	0
18	0.00	0.002	0.002
19	0.00	0	0
20	3.26	3.255	3.255
21	3.26	3.255	3.255
22	0.00	0	0
23	0.58	0.17	0.17
24	0.00	0	0
25	1.86	1.852	1.848
26	0.00	0	0
27	0.00	0	0

MODE PIN NO.	EE	PB	REC
28	3.26	3.254	3.253
29	3.26	3.255	3.25
30	0.00	0.954	0.978
31	1.86	1.855	1.852
32	0.00	0	0
33	0.00	0	0
34	3.26	3.254	3.252
35	0.03	1.029	0.964
36	0.03	1.029	0.522
37	0.00	0	0
38	3.26	3.252	3.252
39	0.00	0	0
40	1.54	1.566	1.566
41	1.86	1.855	1.854
42	0.00	0	0
43	1.47	1.642	1.642
44	1.19	1.643	0.199
45	1.46	0.399	0.405
46	0.12	1.299	1.303
47	0.12	0.369	0.37
48	3.26	3.252	0.252
49	0.00	0	0
50	1.33	0.372	0.376
51	0.46	0.369	0.379
52	0.43	0.382	0.372
53	0.00	0.392	0.397
54	0.03	1.855	0.382
55	1.86	0.39	1.852
56	0.00	1.855	0
57	1.20	0	0.866
58	0.41	1.059	0.7
59	0.41	1.056	0.759
60	0.37	1.05	0.716
61	3.26	3.253	3.252
62	0.00	0	0.099
63	0.03	0.944	1.004
64	0.03	0.965	0.669
65	0.31	0.879	0.93
66	0.03	0.943	1.034
67	1.86	1.856	1.852
68	0.00	0	0
69	0.00	0	0
70	0.39	1.022	1.054
71	0.00	1.53	1.53
72	0.03	2.942	2.942
73	0.00	0.082	0.082
74	0.80	0.082	0.861
75	0.65	0.792	0.672
76	1.86	1.852	1.848
77	0.00	0	0
78	1.86	1.853	1.849
79	0.00	0	0
80	0.05	0.001	0.003
IC 501			
1	1.324	1.322	1.325

MODE PIN NO.	EE	PB	REC
2	0.006	0.004	0.006
3	0.32	0.314	0.321
4	0.4	0.397	0.402
5	3.202	3.091	3.224
6	3.224	3.079	3.204
7	0.005	0.007	0.006
8	1.421	1.423	1.422
IC 5101			
1	1.136	1.215	1.122
2	0.007	0.005	0.01
3	0.006	0.004	0.009
4	1.63	1.628	1.616
5	0.006	0.006	0.008
6	3.217	3.232	3.186
7	3.191	3.206	3.16
8	3.214	3.229	3.183
9	1.835	1.57	1.812
10	1.072	0.969	1.068
11	0.992	1.316	0.996
12	1.5	1.381	1.492
13	1.148	0.982	1.152
14	1.098	1.25	1.092
15	1.07	1.232	1.07
16	1.133	1.206	1.111
17	3.207	3.246	3.183
18	0.007	0.006	0.005
19	1.54	0.262	0.18
20	3.206	3.247	3.192
21	3.207	3.246	3.19
22	0.007	0.006	0.007
23	0.004	0.006	0.008
24	0.939	0.941	0.943
25	3.248	3.215	3.19
26	0.005	0.006	0.008
27	0.903	0.827	0.91
28	3.248	3.216	3.197
29	0.005	0.006	0.019
30	0.865	0.796	0.872
31	3.247	3.216	3.194
32	0.004	0.006	0.006
33	0.005	0.007	0.008
34	3.206	3.185	3.165
35	0.005	0.006	0.007
36	3.235	3.207	3.19
37	0.012	0.009	0.01
38	0.01	0.006	0.007
39	3.235	3.204	3.188
40	3.243	3.212	3.199
41	3.242	3.21	3.197
42	3.242	3.209	3.195
43	0.008	0.009	0.011
44	0.005	0.005	0.007
IC 802			
1	2.52	2.52	2.52
2	2.49	2.49	2.5

MODE PIN NO.	EE	PB	REC
3	1.68	1.67	1.68
4	1.63	1.63	1.64
5	1.65	1.65	1.65
6	1.64	1.64	1.64
7	1.64	1.64	1.64
8	0	0	0
9	4.94	4.94	4.94
10	4.94	4.94	4.94
11	3.25	3.25	3.25
12	3.25	3.25	3.25
13	0.01	0.01	0.01
14	3.25	3.25	3.25
15	2.41	2.41	2.42
16	2.48	2.48	2.49
17	2.43	2.48	2.41
18	2.43	2.44	2.41
19	2.48	2.48	2.48
20	4.94	4.95	4.95
21	0	0	0.01
22	4.79	4.78	4.79
23	4.91	4.91	4.91
24	2.52	2.51	2.51
25	2.42	2.41	2.41
26	2.42	2.41	2.41
27	2.52	2.52	2.51
28	4.89	4.88	4.89
IC601			
	EE	NO Conn.	REC
1	1.62	1.62	1.62
2	1.06	0.05	1.06
3	0.01	0.01	0.01
4	0.5	0.03	0.5
5	0.5	0.03	0.5
6	0.02	0	0.02
7	0.02	0	0.02
8	0.02	0	0.02
9	0.02	0	0.02
10	0.02	0	0.02
11	0.02	0	0.02
12	0	0	0
13	3.26	3.27	3.26
14	0	0	0
15	0	0	0
1	60	0	0
17	0	0	0
18	0	0	0
19	3.23	3.23	3.23
20	3.11	3.12	3.11
21			

• IC BLOCK DIAGRAMS

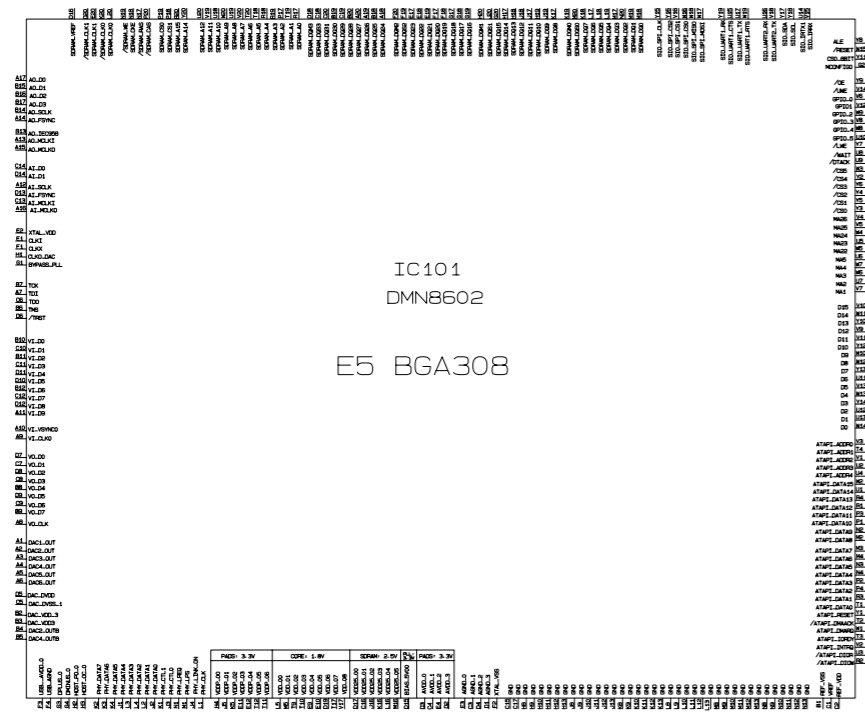

IC101_DMN8602

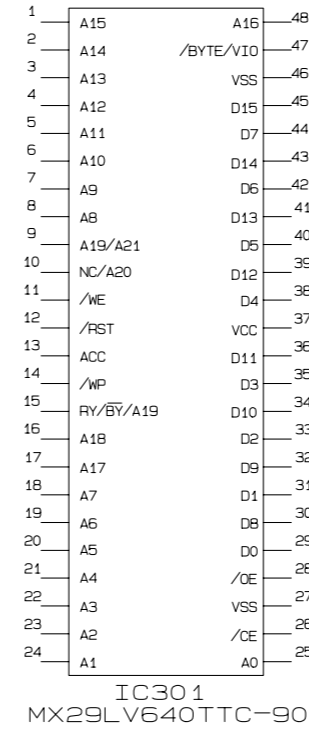

IC301_MX29LV640TTC-90

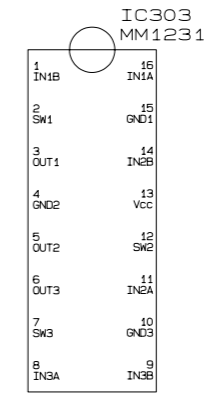

IC303_MM1231

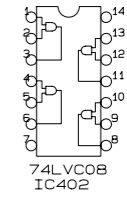

IC402_74LVC08

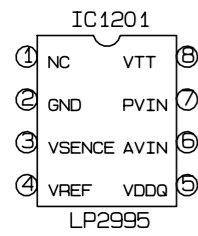

IC1201_LP2995

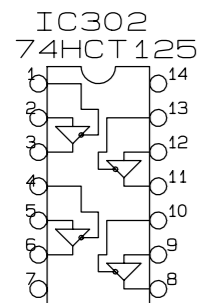

IC302_74HCT125

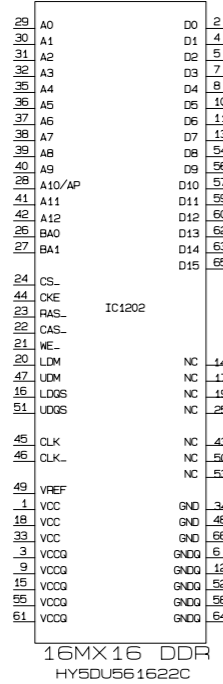

IC1202_16MX16 DDR

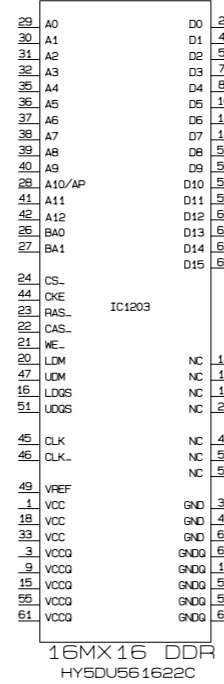

IC1203_16MX16 DDR

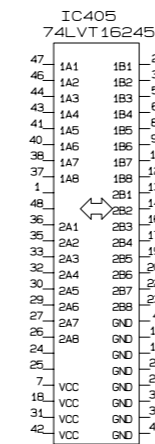

IC405_74LVT16245

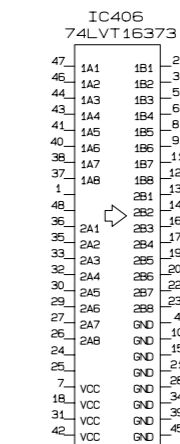

IC406_74LVT16373

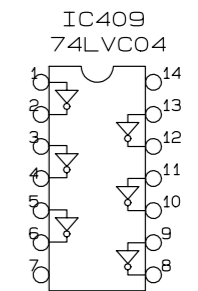

IC409_74LVC04

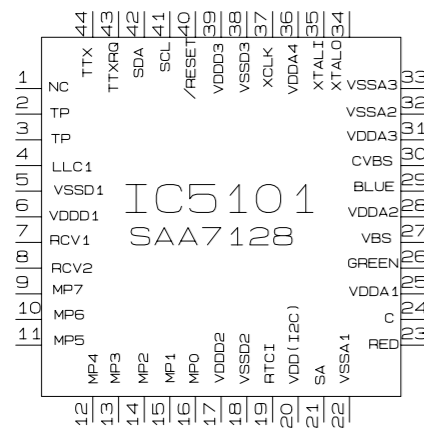

IC5101_SAA7128

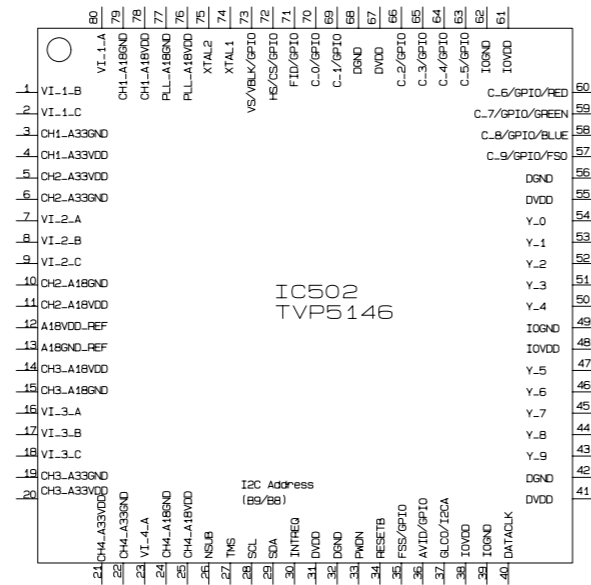

IC5101_SAA7128

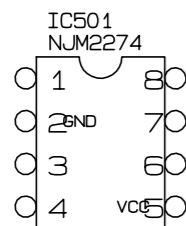

IC501_NJM2274

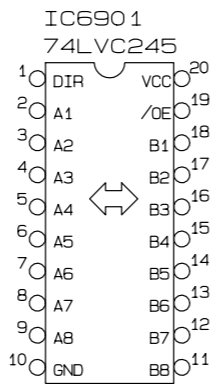

IC6901_74LVC245

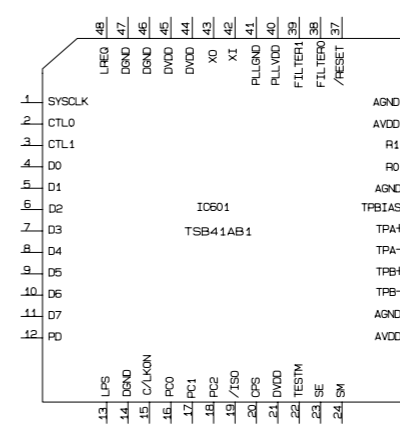

IC601_TSB41AB1

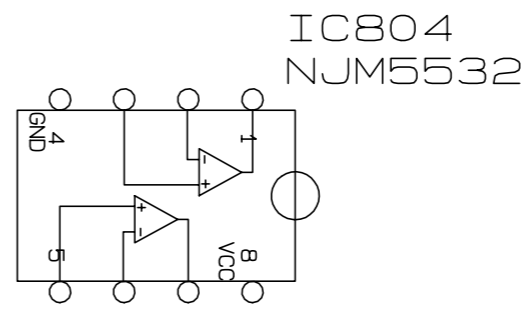

IC804_NJM5532

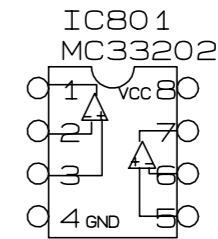

IC801_MC33202

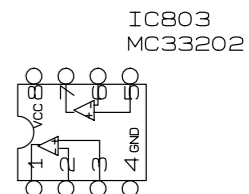

IC803_MC33202

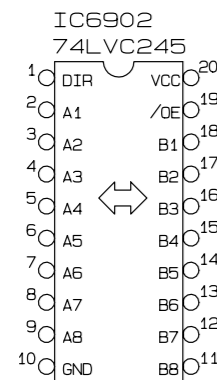

IC6902_74LVC245

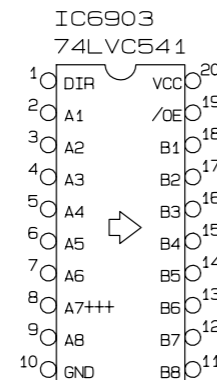

IC6903_74LVC541

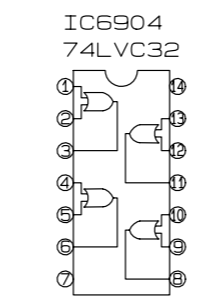

IC6904_74LVC32

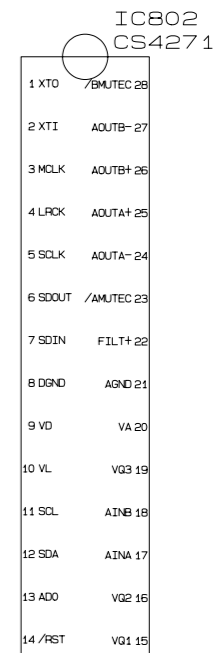

IC802_CS4271

PRINTED CIRCUIT DIAGRAMS

1. VDR P.C.BOARD(TOP VIEW)

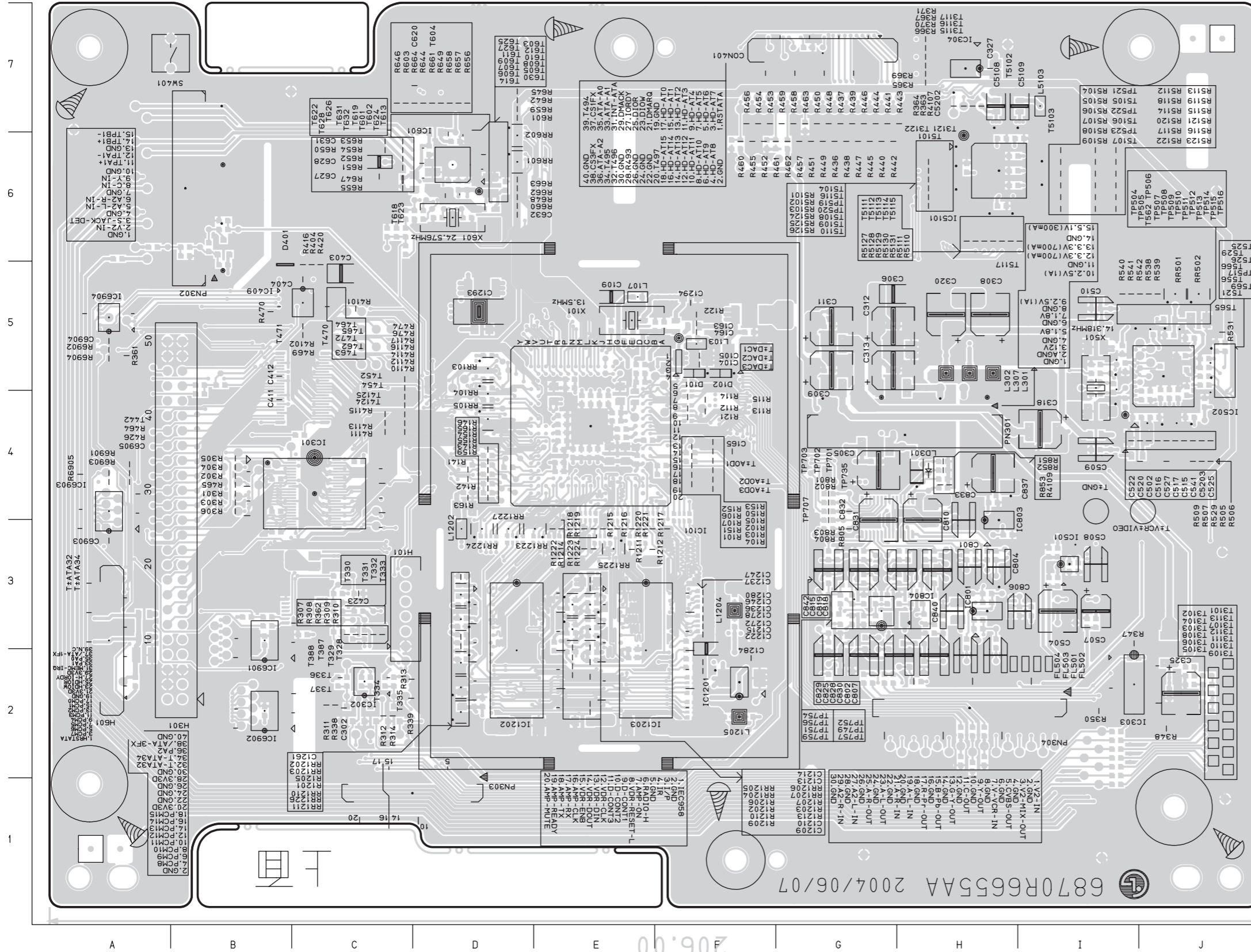

LOCATION GUIDE

C104	F5	C517	J4	IC301	C4	R1211	E3	R364	H7	R463	G7	R603	C7	RR1226	D2	T5101	H7	T631	D7
C105	F5	C520	J4	IC302	C2	R1212	E3	R365	H7	R464	A4	R642	D7	RR1227	D3	T5102	H7	T632	D7
C109	F5	C5202	H7	IC303	I2	R1213	E2	R366	H7	R465	B4	R644	D7	RR501	J5	T5103	I7	TP504	I5
C1209	F2	C5203	J4	IC304	H7	R1214	E3	R367	H7	R469	C5	R645	D7	RR502	J5	T5104	H6	TP505	I5
C1210	F2	C522	J4	IC409	C5	R1215	E3	R369	H7	R470	B5	R646	C7	RR601	D6	T5105	I6	TP506	J5
C1213	F2	C525	J4	IC501	I3	R1216	E3	R370	H7	R474	C5	R647	C6	RR602	D6	T5106	I6	TP507	J5
C1214	F3	C527	J4	IC502	J5	R1217	F3	R371	H7	R476	C5	R648	D6	SW401	A7	T5107	I6	TP508	J5
C1215	F2	C541	J4	IC510	H6	R1218	E3	R404	C5	R505	J4	R649	D7	T111	D4	T5108	H6	TP509	J5
C1222	F2	C620	D7	IC601	D6	R1219	E3	R4101	C5	R506	J4	R650	C6	T3101	J2	T5109	H6	TP510	J5
C1236	F3	C627	C6	IC690	B3	R122	F5	R4102	C5	R507	J4	R651	C6	T3102	J2	T5110	H6	TP511	J5
C1237	F3	C628	C6	IC6902	B2	R1220	E3	R4107	H7	R509	J4	R652	C6	T3103	J2	T5111	H6	TP512	J5
C1246	F3	C631	C6	IC6903	A4	R1221	E3	R4109	H4	R5101	H6	R653	C6	T3104	J2	T5112	H6	TP513	J5
C1247	F3	C632	D6	IC6904	A5	R1222	E3	R4110	C4	R5102	H6	R654	C6	T3105	J2	T5113	H6	TP514	J5
C1261	D3	C6903	A3	IC801	H3	R1223	E3	R4111	C4	R5103	H6	R655	C6	T3106	J2	T5114	H6	TP515	J5
C1272	F3	C6904	A5	IC803	H3	R1224	E3	R4112	C4	R5104	I6	R656	D7	T3107	J2	T5115	H6	TP516	J5
C1278	F3	C6905	A4	IC804	G3	R141	D4	R4113	C4	R5105	I6	R657	D7	T3108	J2	T5116	H6	TP517	J5
C1280	F3	C801	H3	L103	F5	R142	D4	R4114	C4	R5106	I6	R658	D7	T3109	J2	T5117	H6	TP519	H6
C1284	F3	C802	H2	L107	E5	R143	D4	R4115	C4	R5107	I6	R659	D7	T3110	J2	T521	J4	TP520	H6
C1293	D5	C804	H3	L1202	D3	R146	D4	R4116	C4	R5108	I6	R660	D6	T3111	J2	T525	J5	TP521	I6
C1294	F5	C806	I3	L1204	F3	R150	F4	R4117	C4	R5109	I6	R661	D7	T3112	J2	T526	J5	TP522	I6
C163	F5	C807	H2	L1205	F2	R151	F4	R416	C5	R5110	I6	R662	D6	T3113	J2	T529	J5	TP523	I6
C164	F5	C810	H3	L301	H5	R152	F4	R420	C5	R5111	H6	R663	D6	T3115	H7	T556	J5	TP701	G4
C165	F4	C815	G3	L302	H5	R153	F4	R426	A4	R5112	I6	R664	D7	T3116	H7	T562	J5	TP702	G4
C302	C2	C818	H3	L307	H5	R154	D4	R436	G6	R5113	I6	R6901	A4	T3117	H7	T565	J5	TP703	G4
C305	G4	C819	H3	L5103	I7	R155	D4	R437	G7	R5114	I6	R6902	A5	T3121	H7	T566	J5	TP707	G3
C306	G5	C825	G2	LD301	H4	R159	D4	R438	G7	R5115	I6	R6903	A4	T3122	H7	T569	J5	TP729	G3
C308	H5	C828	H2	PN301	H4	R163	D4	R439	G7	R5116	I6	R6904	A5	T328	C2	T601	D7	TP734	G3
C309	G5	C829	G2	PN302	B6	R165	D4	R440	G6	R5117	I6	R6905	A4	T329	C2	T602	D7	TP735	G4
C311	G5	C830	H2	PN303	C1	R301	B4	R441	G7	R5118	I6	R801	G4	T330	C3	T603	D6	TP749	H3
C312	G5	C831	G3	PN304	H2	R302	B4	R442	G6	R5119	I6	R802	G4	T331	C3	T604	D7	TP751	G3
C313	G5	C832	G4	R101	F4	R303	B4	R443	H7	R5120	I6	R803	G4	T332	C3	T605	D6	TP752	H3
C318	I4	C833	H3	R102	F4	R304	B4	R444	G7	R5121	I6	R804	G3	T333	C3	T606	D6	TP754	G3
C320	H5	C837	H4	R103	F4	R305	B4	R445	G7	R5122	I6	R805	G3	T334	C2	T607	D6	TP756	G3
C325	J2	C840	H3	R104	F4	R306	B4	R446	G7	R5123	I6	R851	H4	T335	C2	T608	D6	TP757	H3
C327	H7	C842	G3	R105	F4	R307	C3	R447	G6	R5124	H6	R852	H4	T336	C2	T609	D6	TP759	G3
C403	C5	CON40	G7	R106	F4	R308	C3	R448	G7	R5125	H6	R853	H4	T337	C2	T610	D6	T±A0D1	F4
C404	C5	D101	F5	R107	F4	R309	C3	R449	G6	R5126	H6	RR103	D5	T387	C2	T611	D6	T±A0D2	F4
C411	B4	D102	F5	R112	F4	R310	C3	R450	G7	R5127	H6	RR104	D4	T388	C2	T612	D6	T±A0D3	F4
C412	B5	D401	B5	R113	F4	R311	C2	R451	G6	R5128	H6	RR105	D4	T4124	C4	T613	D7	T±ATA32	A3
C423	C3	FL501	I2	R114	F4	R312	C2	R452	F6	R5129	H6	RR1202	D3	T4125	C4	T614	D6	T±ATA34	A3
C502	J4	FL502	I2	R115	F4	R313	C2	R453	F7	R5130	H6	RR1203	D3	T442	A4	T618	C6	T±DAC1	F5
C504	I3	FL503	I2	R1201	D3	R314	C2	R454	F7	R5131	H6	RR1204	E3	T452	C5	T619	D7	T±DAC2	F5
C507	I3	FL504	H2	R1202	E2	R338	C2	R455	F6	R529	J4	RR1205	E3	T454	C5	T622	C7	T±DAC3	F5
C508	I3	H101	C3	R1203	E2	R339	C2	R456	F7	R531	J5	RR1206	E3	T462	C5	T623	C6	T±GND1	I4
C509	I4	H301	B2	R1205	D3	R347	I3	R457	G6	R538	J5	RR1207	E3	T463	C5	T624	D7	T±VCR	J4
C510	I5	H601	A3	R1206	E3	R348	J2	R458	G7	R539	J5	RR1210	D2	T464	C5	T625	D7	±VIDEO	
C5108	H7	IC101	E4	R1207	E3	R350	I2	R459	G7	R540	I5	RR1211	D2	T465	C5	T626	C7	X101	I5
C5109	I7	IC1201	F2	R1209	E2	R361	A5	R460	F6	R541	I5	RR1223	E3	T470	C5	T627	D6	X501	I5
C515	J4	IC1202	D2	R121	F4	R362	C3	R461	F6	R542	J5	RR1224	D3	T471	B5	T628	C6	X601	D6
C516	J4	IC1203	E2	R1210	E2	R363	H7	R462	G6	R601	D7	RR1225	E3	T472	C5	T630	D6		

LOCATION GUIDE

/CS4 G5	C129 F4	C5201 A5	IC406 H4	R349 B2	R816 C3	T2A409 E7	T370 J7	T468 I6	TP733 C3
/CS5 G5	C1290 E5	C521 A4	IC802 D4	R351 A2	R817 D3	T2A410 D7	T371 J6	T469 I6	TP736 C3
/DTACK G4	C1291 G4	C523 A4	L102 F4	R352 A2	R819 C3	T2B401 D7	T372 J6	T481 E7	TP737 C3
/UWE F4	C1292 G4	C524 A4	L104 F4	R353 D2	R820 D2	T2B402 D6	T373 J7	T482 E7	TP738 C3
ATA1FX J5	C1295 E3	C526 B5	L105 F5	R354 D2	R821 C3	T2B403 D6	T374 C5	T486 H3	TP739 C3
ATA3V3D J2	C1296 E3	C528 A4	L106 F5	R355 D2	R822 C2	T2B404 E6	T375 D4	T487 H3	TP740 C3
BST±/T5	C131 F5	C529 A4	L1201 E5	R356 D2	R824 C3	T2B405 E7	T376 C4	T489 D7	TP741 D3
BST±TC4	C132 F4	C530 B3	L1203 G5	R357 A2	R825 D2	T2B408 D7	T377 C4	T490 D7	TP742 C3
BST±TDI E4	C133 F4	C531 B5	L303 B4	R358 A2	R826 C3	T2B409 D7	T378 C5	T493 I4	TP743 D3
BST±TDO E5	C134 F4	C532 A4	L304 D5	R359 H3	R827 C3	T2C404 E7	T379 D5	T494 E7	TP744 D3
BST±TMS F4	C135 F4	C533 A4	L305 D5	R360 H3	R828 C3	T301 H5	T380 B7	T495 D7	TP745 D3
C101 E5	C136 F4	C534 B4	L306 D4	R401 H2	R829 D3	T302 H5	T381 D5	T496 D7	TP746 D3
C103 F5	C140 F4	C535 B5	L308 D5	R407 I3	R830 D3	T303 H5	T382 D4	T497 D7	TP747 D3
C106 E5	C141 F4	C536 A4	L309 A2	R408 I3	R831 D3	T304 I4	T383 D4	T519 B3	TP748 C3
C107 E5	C142 F4	C537 B4	L501 B4	R410 H2	R832 C3	T305 H5	T384 C5	T520 B3	TP750 C3
C108 F5	C145 F4	C538 B4	L502 B4	R4103 H6	R833 C3	T306 H5	T385 H3	T527 B3	TP753 D3
C111 F4	C146 F4	C539 B4	L503 B5	R4104 H6	R834 D3	T307 H5	T386 H5	T528 B3	TP755 D3
C112 F4	C149 F4	C540 A4	L504 A5	R4106 A5	R835 D3	T308 I4	T389 H2	T530 B5	TP758 C3
C113 F4	C151 F4	C542 A5	L5101 C7	R4108 H6	R836 D3	T309 H5	T390 H2	T532 B5	TP760 D3
C115 F4	C152 E4	C543 A5	L5102 B7	R4120 H4	R837 D3	T310 I4	T391 B2	T539 B3	TP761 D3
C116 F4	C153 F5	C621 G6	L607 G6	R4121 I3	R838 D3	T311 H5	T392 B2	T555 B3	TP762 D2
C117 F4	C154 F5	C622 G6	L608 G6	R4122 H6	R839 C4	T3114 J5	T393 B1	T557 B5	TP763 D3
C118 F4	C155 F5	C623 H6	L6901 J3	R4123 H6	R841 D3	T3119 C7	T394 B2	T558 A5	TP764 C2
C120 F4	C156 F5	C624 G6	L6902 J3	R4225 I4	R842 C3	T312 H5	T395 B2	T559 A5	TP765 D2
C1201 G2	C157 F5	C625 G6	L6903 G6	R427 I6	R843 D3	T3120 C7	T396 B2	T560 A5	TP766 C2
C1202 G2	C158 F4	C626 G6	L801 D3	R428 I6	R844 D3	T313 H5	T402 D7	T561 A5	TP767 D2
C1203 G2	C162 F4	C629 G6	L802 C4	R429 J6	R845 C4	T314 H5	T403 I3	T563 A5	T±/ATA± J5
C1204 G3	C301 H4	C630 G6	L803 C3	R430 I5	R846 C4	T315 H4	T404 D7	T564 B5	T±G3 F5
C1205 G2	C303 D5	C633 G6	L804 C4	R431 I6	R847 D4	T316 I4	T405 J4	T568 A5	T±G4 F5
C1206 G2	C304 D5	C634 G6	Q401 I6	R432 H2	R848 D4	T317 I4	T406 J4	T570 B4	T±H2 F5
C1207 G3	C307 C5	C635 G6	Q402 H2	R433 H2	R849 D4	T318 H5	T407 C7	T615 G6	T±H3 F5
C1208 F2	C310 D4	C636 G6	Q403 H2	R434 H2	R850 D3	T319 I4	T408 D7	T616 G6	T±HATA J5
C121 E5	C314 D5	C637 G6	Q404 H2	R435 H2	RR101 E5	T320 H5	T409 D7	T617 G6	T±HD10R J4
C1211 F2	C315 B4	C638 G6	Q803 C2	R467 I5	RR102 E4	T321 H5	T410 D7	T620 G6	T±HD10W J4
C1212 F2	C316 D5	C6901 I2	Q804 D2	R468 I5	RR1201 F3	T322 H3	T4101 J3	T621 G6	T±JORDY J4
C1221 F3	C317 D5	C6902 I3	Q807 D3	R473 H3	RR1208 E3	T323 I4	T4102 J3	T629 H6	T±PA0 J4
C1223 F2	C319 C5	C803 C3	Q808 E6	R478 E6	RR1209 E3	T324 I4	T4103 I4	T633 G6	T±PA1 J3
C123 G5	C321 A2	C805 C3	R116 E5	R479 D7	RR1212 E2	T325 I4	T4104 J4	TP501 B5	T±PA2 J3
C1248 F2	C322 A2	C808 C3	R1204 E2	R484 H3	RR1213 E2	T326 I4	T4105 I4	TP502 A5	T±PD0 I2
C1249 F3	C323 A2	C809 C4	R1225 E2	R485 E6	RR1214 F3	T327 H5	T4106 J4	TP503 A5	T±PD1 I2
C1250 F3	C324 A2	C812 D3	R1226 E2	R486 E6	RR1215 F4	T338 H2	T411 D7	TP518 C7	T±PD10 I2
C1251 F3	C326 A2	C813 D3	R1227 E2	R493 D7	RR1216 F3	T339 H2	T412 D7	TP524 A4	T±PD11 I3
C1252 F3	C401 I6	C814 D3	R124 G4	R498 H3	RR1217 F4	T340 H2	T4123 I4	TP601 G6	T±PD12 I3
C1253 G3	C402 I6	C816 D3	R125 F5	R499 H3	RR1218 F3	T341 H2	T4126 I4	TP602 G6	T±PD13 I3
C1254 G3	C405 I4	C817 C3	R144 G4	R502 A5	RR1219 E4	T342 A2	T4127 H6	TP704 D4	T±PD14 I3
C1255 F2	C408 H3	C820 C3	R147 G5	R503 A5	RR1220 E4	T343 H2	T413 D7	TP705 D4	T±PD15 I3
C1256 F3	C410 I4	C821 C3	R149 G4	R508 C2	RR1221 G3	T344 B2	T415 D7	TP706 D4	T±PD2 I2
C1257 F3	C413 E6	C822 C3	R156 G4	R510 B5	RR1222 G3	T345 H2	T416 D7	TP708 D3	T±PD3 I2
C1258 F3	C414 H3	C823 D3	R157 G4	R512 B3	SDRAM±CSI F4	T346 H2	T417 D7	TP709 C2	T±PD4 I2
C1259 F3	C415 E6	C824 C3	R158 G4	R513 B3	SL301 H3	T347 H2	T418 H3	TP710 C2	T±PD5 I2
C126 F4	C416 H3	C826 C3	R160 G4	R5132 A5	SL302 C7	T348 C2	T419 H3	TP711 C3	T±PD6 I2
C1260 G3	C417 H3	C827 D3	R161 G4	R5133 B5	T101 J7	T349 B2	T420 D7	TP712 B3	T±PD7 I2
C1262 F3	C501 A5	C834 C3	R162 G4	R514 B3	T102 I7	T350 C2	T421 J4	TP713 C3	T±PD8 I2
C1266 G3	C503 B3	C835 C3	R164 G5	R515 B3	T103 G7	T351 C2	T422 I4	TP714 C3	T±PD9 I2
C1267 G3	C505 B3	C836 C3	R166 G4	R516 A5	T104 A1	T352 C2	T423 I4	TP715 C3	U15 G4
C1269 G3	C506 B3	C838 C4	R167 F4	R526 B5	T105 C7	T353 C2	T425 I4	TP716 C3	U16 G4
T127 F5	C5101 C6	C839 B3	R168 E4	R530 B5	T106 A6	T354 C2	T428 D7	TP717 C3	V18 G4
C1270 F3	C5102 B6	C839 B3	R168 E4	R532 B5	T107 J1	T355 B2	T429 D7	TP718 C4	
C1271 F3	C5103 C6	C841 D3	R2A402 H3	R533 A5	T108 A3	T356 C2	T430 J4	TP719 C4	
C1275 F3	C5104 C6	C843 C4	R2B408 I3	R5A0 C2	T109 D1	T357 C2	T434 H3	TP720 D4	
C1276 F3	C5105 C6	CLK0 F5	R315 J6	R6911 J2	T110 B1	T358 B2	T436 J5	TP721 D4	
C1277 F3	C5106 C6	FL505 C2	R316 J6	R806 C3	T112 G4	T359 C2	T443 I5	TP722 D4	
C128 F4	C5107 C6	FL506 C2	R317 J6	R807 B3	T113 E4	T360 C2	T453 G5	TP723 D3	
C1282 E2	C511 B5	FL507 C2	R337 C4	R808 C3	T114 E4	T361 B2	T455 G5	TP724 D3	
C1283 E3	C5110 A5	GP104 G4	R340 B2	R809 C3	T1201 E2	T362 D2	T456 J6	TP725 C4	
C1285 E2	C512 B4	HIORDY J4	R341 B2	R810 C3	T1202 E2	T364 J6	T457 H2	TP726 C4	
C1286 E2	C513 A5	H0ST±RX G4	R342 B2	R811 C3	T1203 E2	T365 J6	T458 H2	TP727 C4	
C1287 F2	C514 A5	H0ST±TX G4	R343 B2	R812 C3	T1204 E2	T366 J6	T459 H2	TP728 C4	
C1288 G2	C518 B5	HRSIATA J4	R344 B2	R813 C3	T2A406 E7	T367 J6	T460 H2	TP730 D3	
C1289 E5	C519 B4	IC402 H3	R345 B2	R814 D3	T2A407 E7	T368 J6	T461 H2	TP731 D3	
		IC405 H5	R346 B2	R815 D3	T2A408 E6	T369 J6	T467 I6	TP732 D3	

2. VDR P.C.BOARD (BOTTOM VIEW)

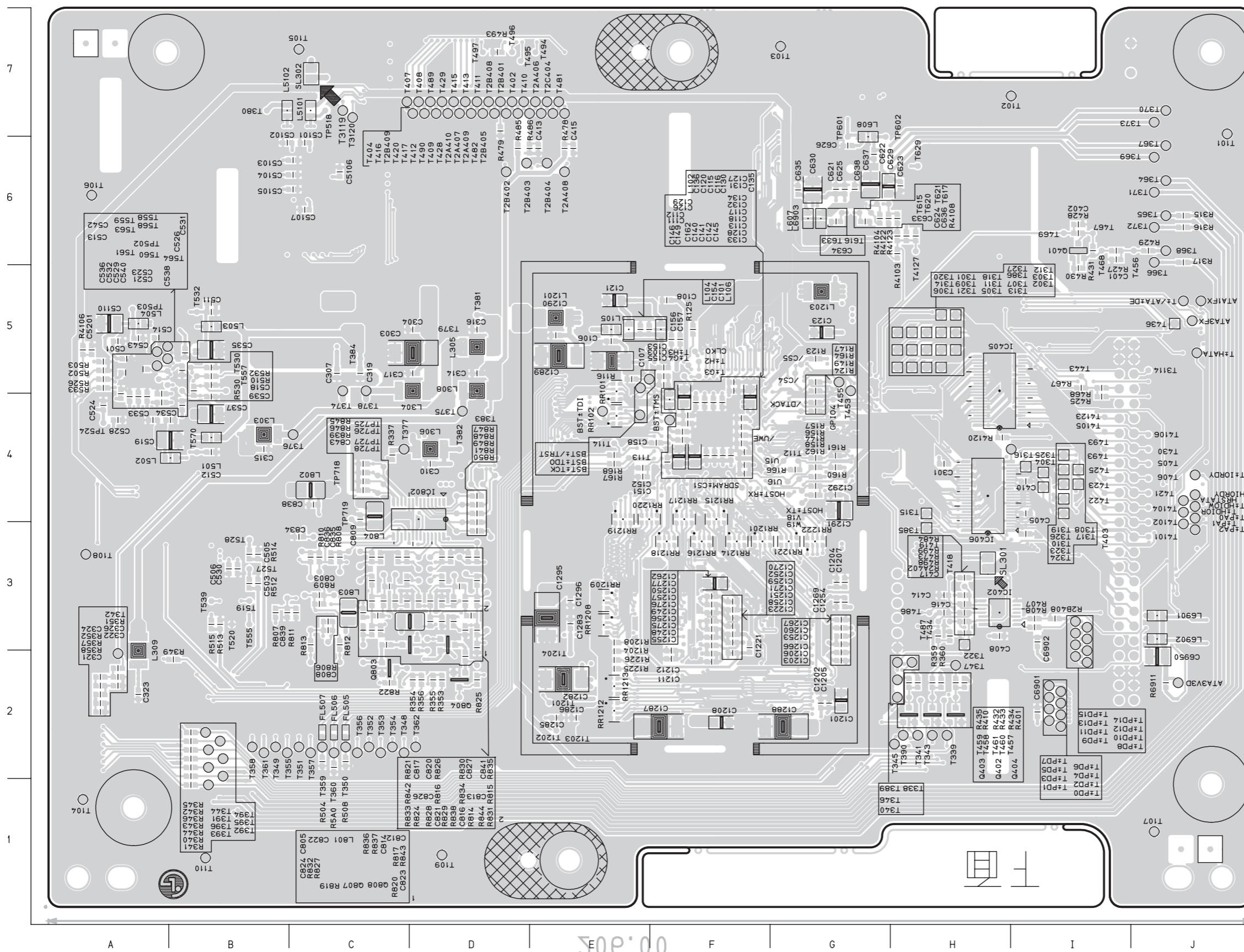

RL-02A LOADER PART

Note: It is not recommended for component repair on this RL-02A Loader Module but to replace the complete loader when it becomes defective.
The Information in this section is published for reference only.

CONTENTS

ELECTRICAL TROUBLESHOOTING GUIDE	3-114	THE DIFFERENCE OF DVD-R/RW, DVD+R/RW DISCS AND DVD-ROM	3-146
WAVEFORMS	3-128	1. RECORDING LAYER	3-146
1. POWER & RESET SIGNAL	3-128	2. DISC SPECIFICATION	3-147
2. MAIN CLOCK1 FOR IC202 (16.9MHZ)	3-128	3. DISC MATERIALS	3-147
3. MAIN CLOCK2 FOR IC302 (20MHZ)	3-129	4. ORGANIZATION OF THE INNER DRIVE AREA, OUTER DRIVE AREA, LEAD-IN ZONE AND LEAD-OUT ZONE	3-151
4. SDRAM CLOCK	3-129	5. ALPC (AUTOMATIC LASER POWER CONTROL) CIRCUIT	3-154
5. TRAY OPEN/CLOSE SIGNAL 1	3-130	HOW TO USE TEST TOOL	3-155
6. TRAY OPEN/CLOSE SIGNAL 2	3-130	BLOCK DIAGRAMS	3-163
7. SLED MOVE SIGNAL 1	3-131	1. OVERALL BLOCK DIAGRAM	3-163
8. SLED MOVE SIGNAL 2	3-131	2. RF BLOCK DIAGRAM	3-164
9. FOCUS SEARCH SIGNAL	3-132	3. DSP BLOCK DIAGRAM	3-165
10. LASER TURN ON SIGNAL	3-132	4. MICOM BLOCK DIAGRAM	3-166
11. DISC TYPE JUDGEMENT WAVEFORM (CD SERIES)	3-133	CIRCUIT DIAGRAMS	3-167
12. DISC TYPE JUDGEMENT WAVEFORM (CD & CD-R)	3-133	1. RF1 CIRCUIT DIAGRAM	3-167
13. DISC TYPE JUDGEMENT WAVEFORM (CD-RW)	3-134	2. RF2 CIRCUIT DIAGRAM	3-169
14. DISC TYPE JUDGEMENT WAVEFORM (DVD SERIES)	3-134	3. DSP CIRCUIT DIAGRAM	3-171
15. DISC TYPE JUDGEMENT WAVEFORM (DVD_SINGLE&R)	3-135	4. MICOM CIRCUIT DIAGRAM	3-173
16. DISC TYPE JUDGEMENT WAVEFORM (DVD_DUAL)	3-135	CIRCUIT VOLTAGE CHART	3-175
17. DISC TYPE JUDGEMENT WAVEFORM (DVDRW)	3-136	PRINTED CIRCUIT DIAGRAMS	3-179
18. SPINDLE WAVEFORM1	3-136	1. MAIN P.C.BOARD (SIDE A)	3-179
19. SPINDLE WAVEFORM2	3-137	2. MAIN P.C.BOARD (SIDE B)	3-183
20. FOCUS ON SIGNAL (CD)	3-137		
21. FOCUS ON SIGNAL (CD)	3-138		
22. FOCUS ON SIGNAL (DVD)	3-138		
23. FOCUS ON SIGNAL (DVD)	3-139		
24. TRACK OFF SIGNAL (CD)	3-139		
25. TRACK OFF SIGNAL (DVD)	3-140		
26. TILT DRIVER SIGNAL (DISC READING)	3-140		
27. RF WAVEFORM (DVD)	3-141		
28. RF WAVEFORM (CD)	3-141		
29. WOBBLE (DVD-R/RW)_READING	3-142		
30. WOBBLE (DVD+R/RW)_READING & WRITING => X1 SPEED	3-142		
31. LD ENABLE (DVD)	3-143		
32. LD ENABLE (CD)	3-143		
33. LASER POWER (READING)_DVD+RW	3-144		
34. LASER POWER (ERASE)_DVD+RW	3-144		
35. LASER POWER (WRITING)_INITIAL STATE ..	3-145		
36. LASER POWER (WRITING)_PROCESSING ...	3-145		

RL-02A LOADER PART ELECTRICAL TROUBLESHOOTING GUIDE

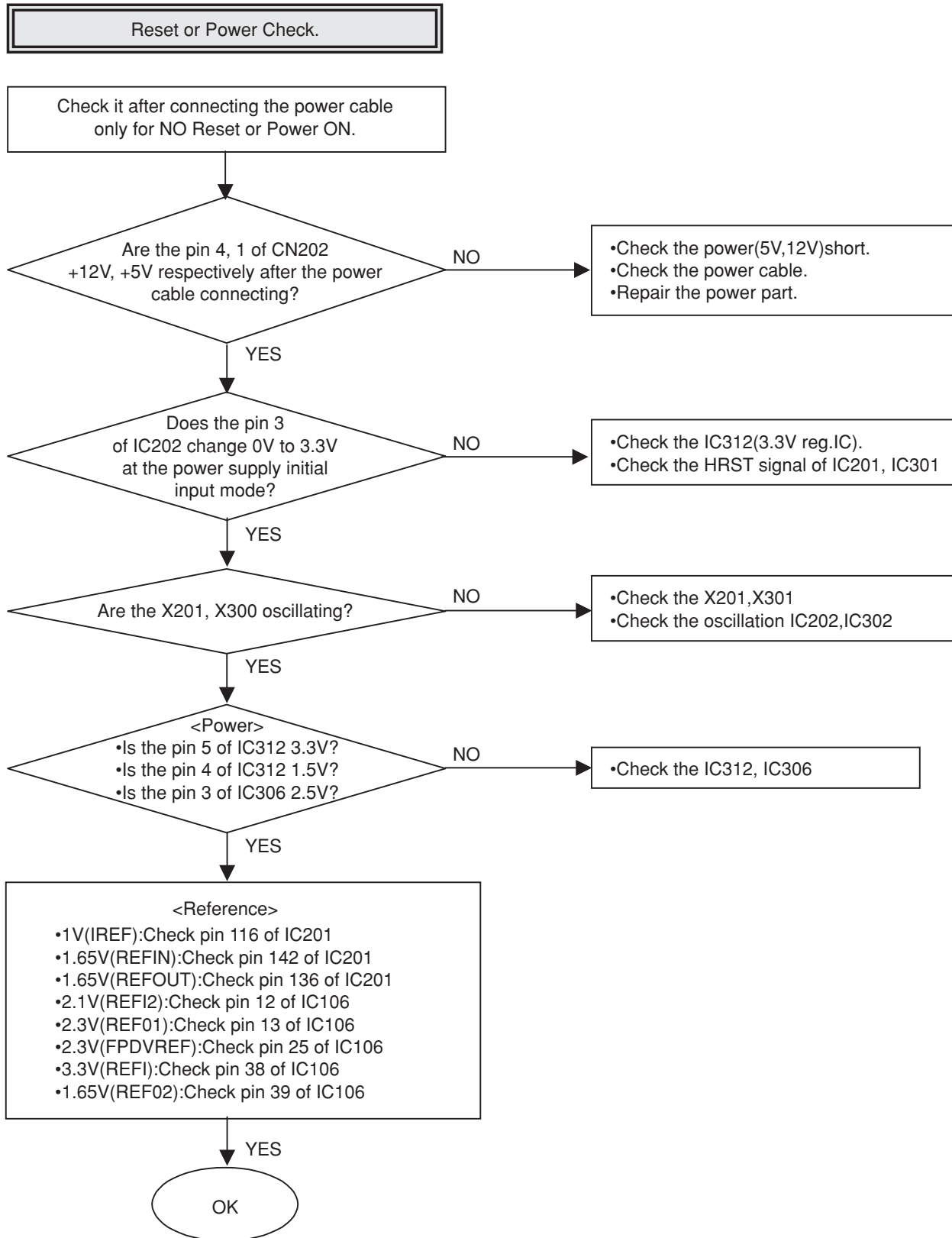

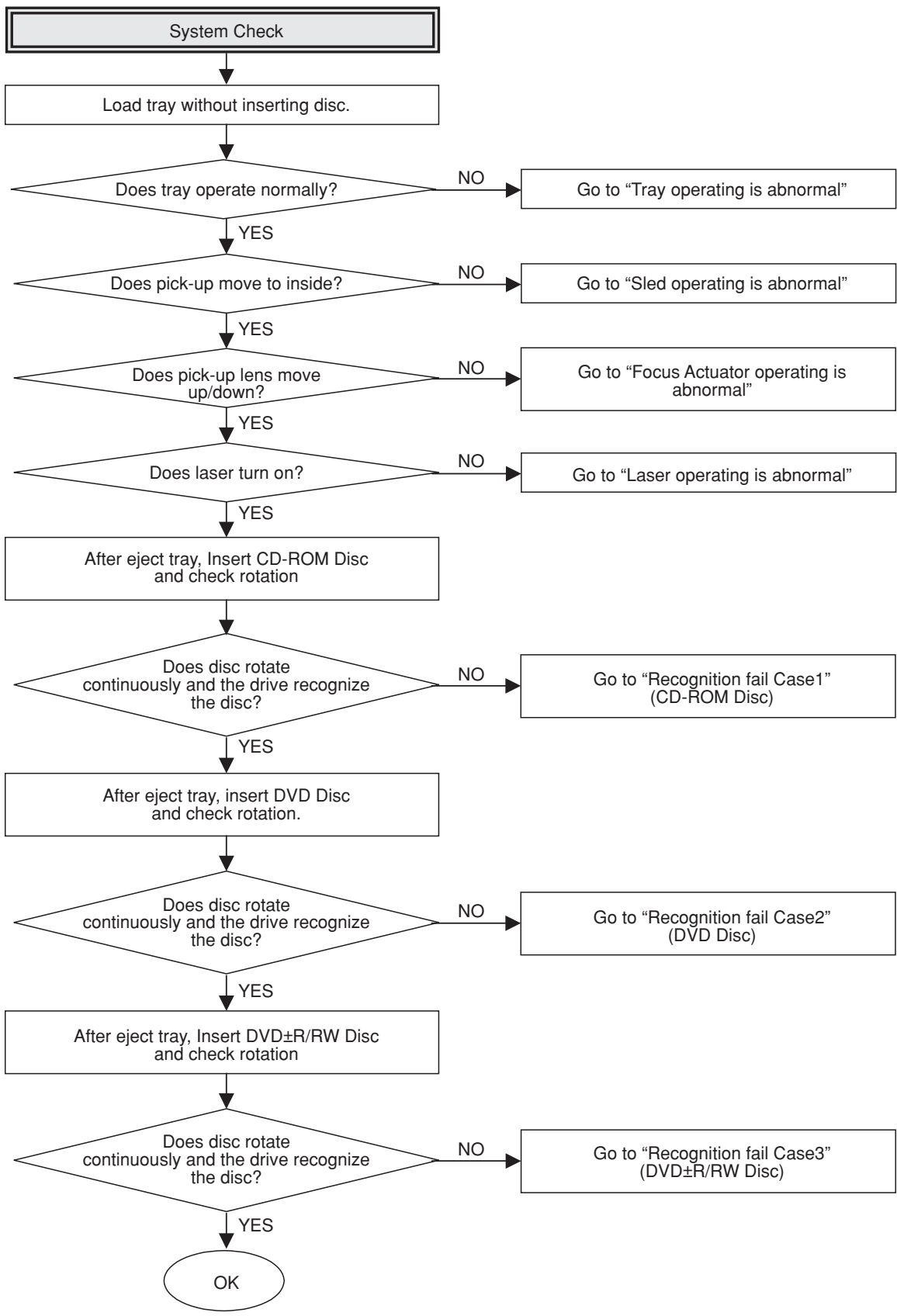

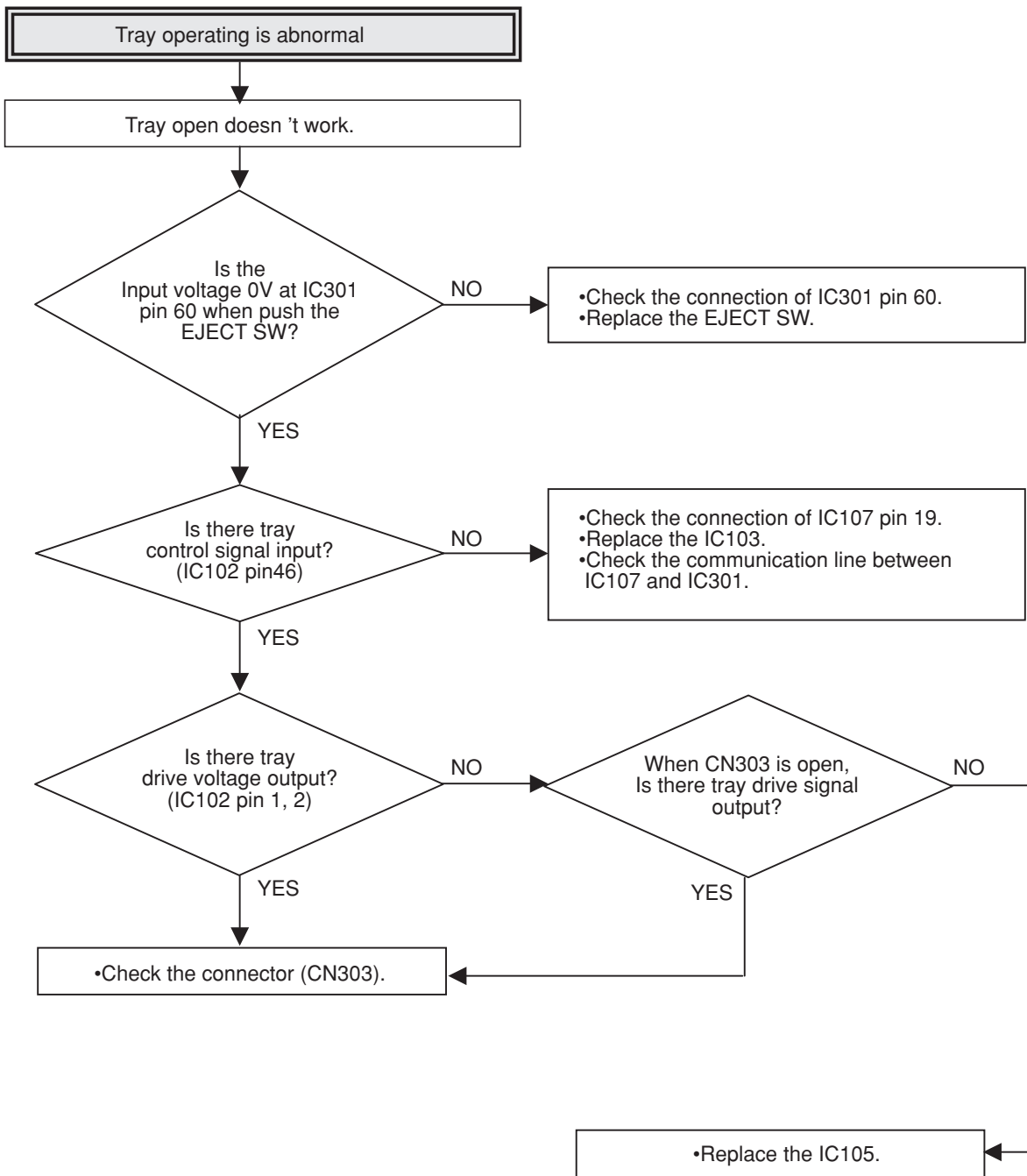

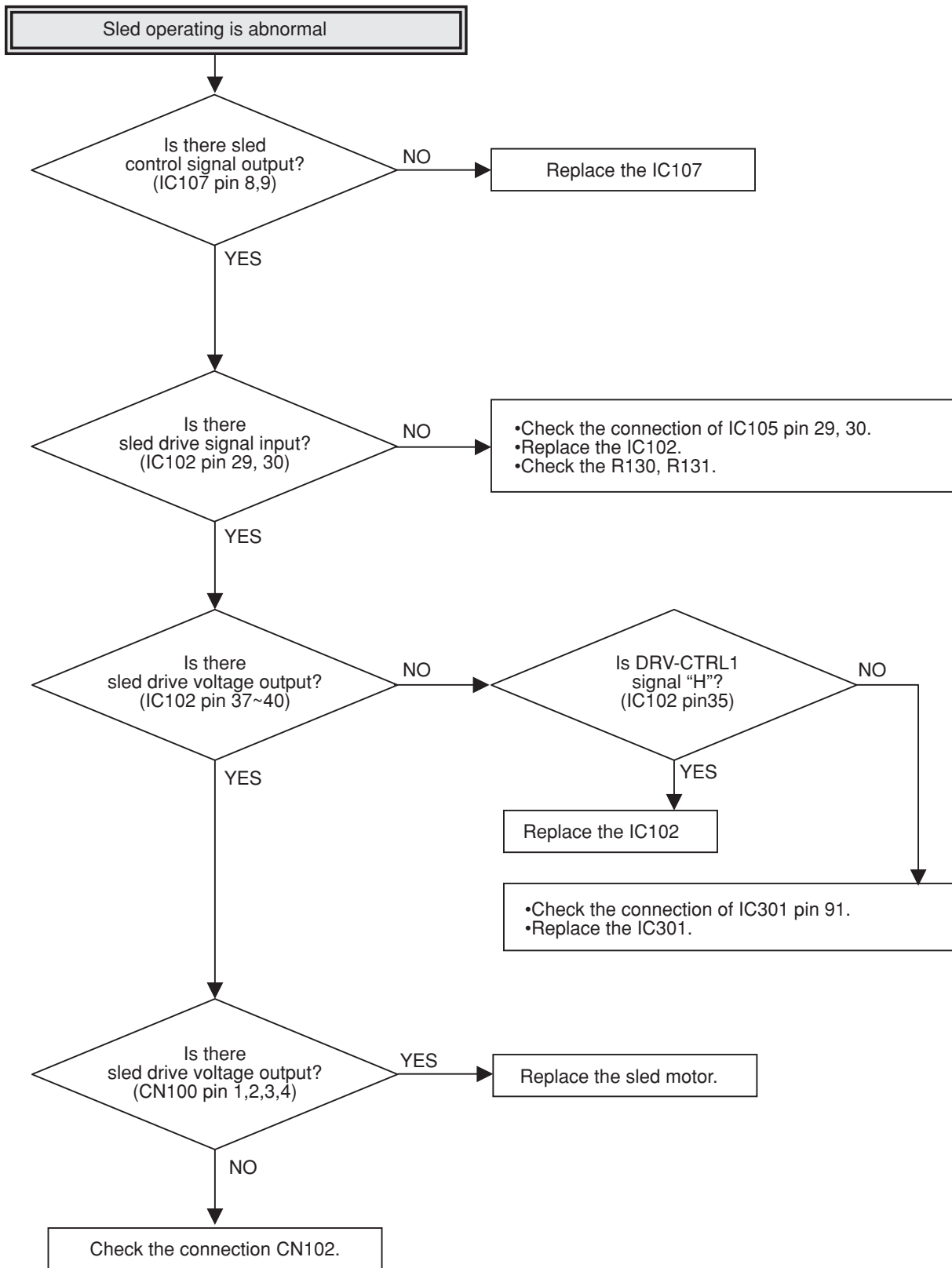

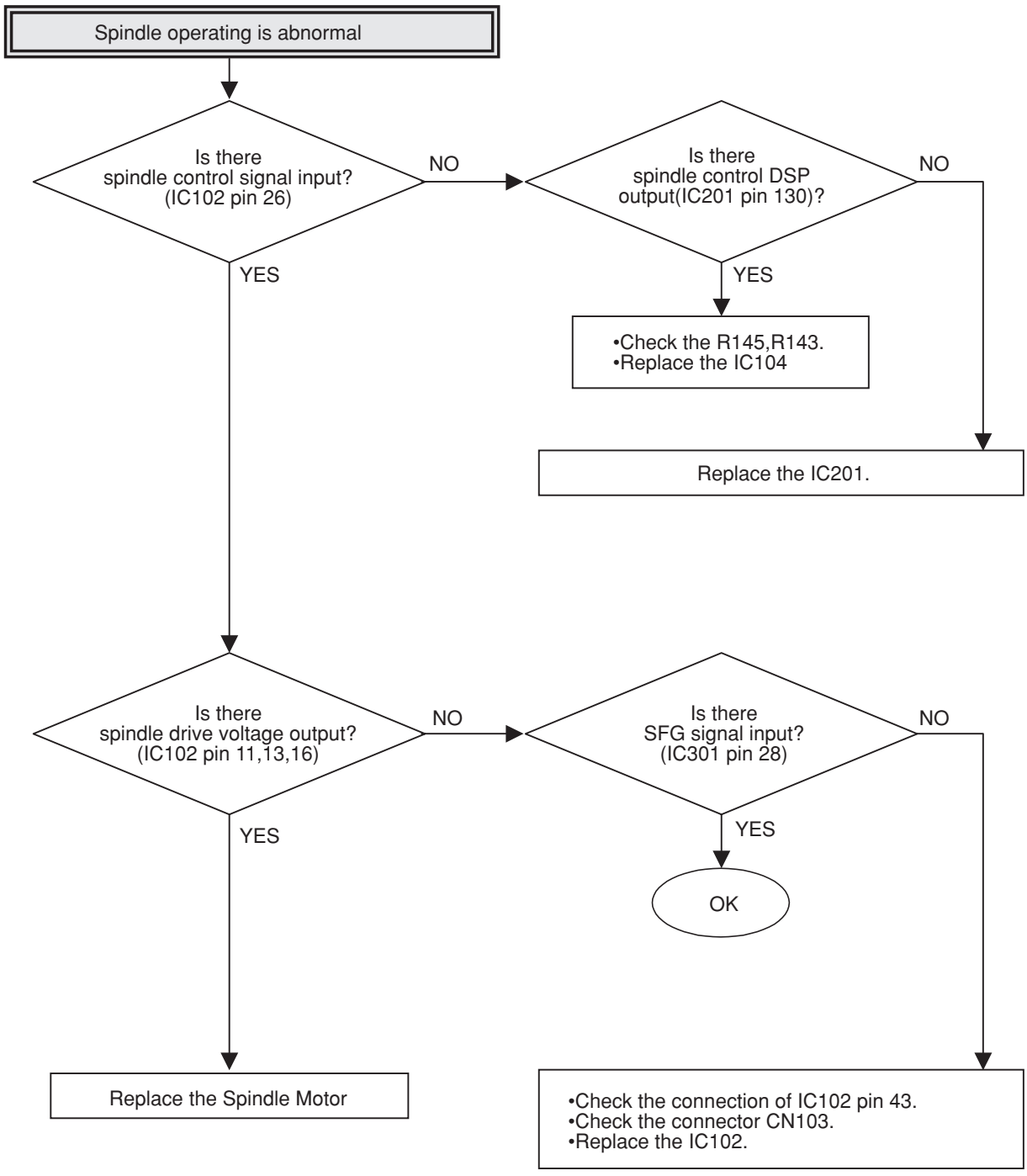

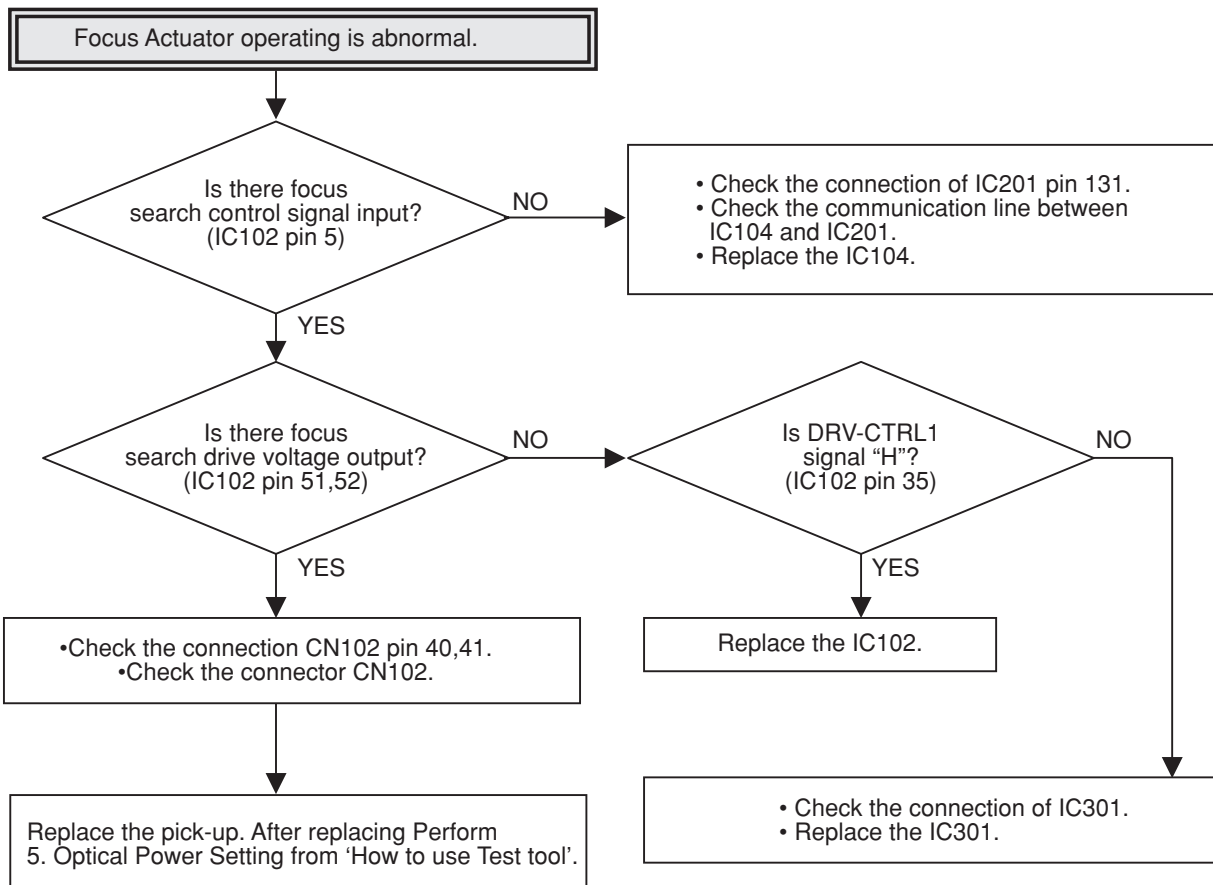
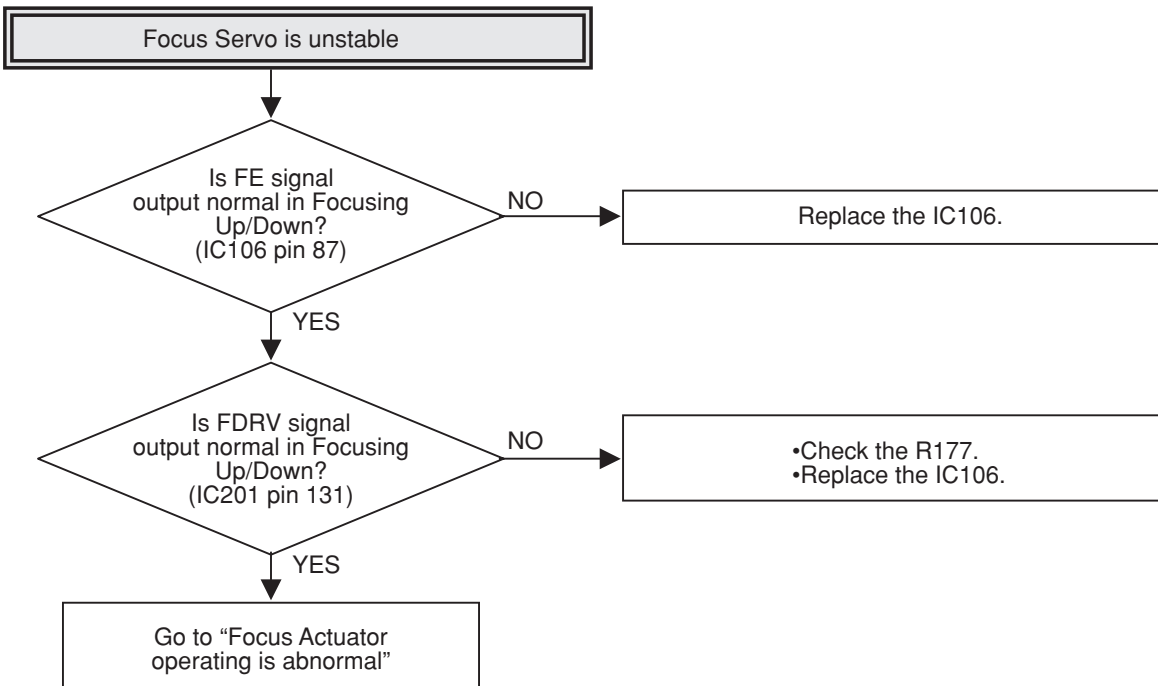

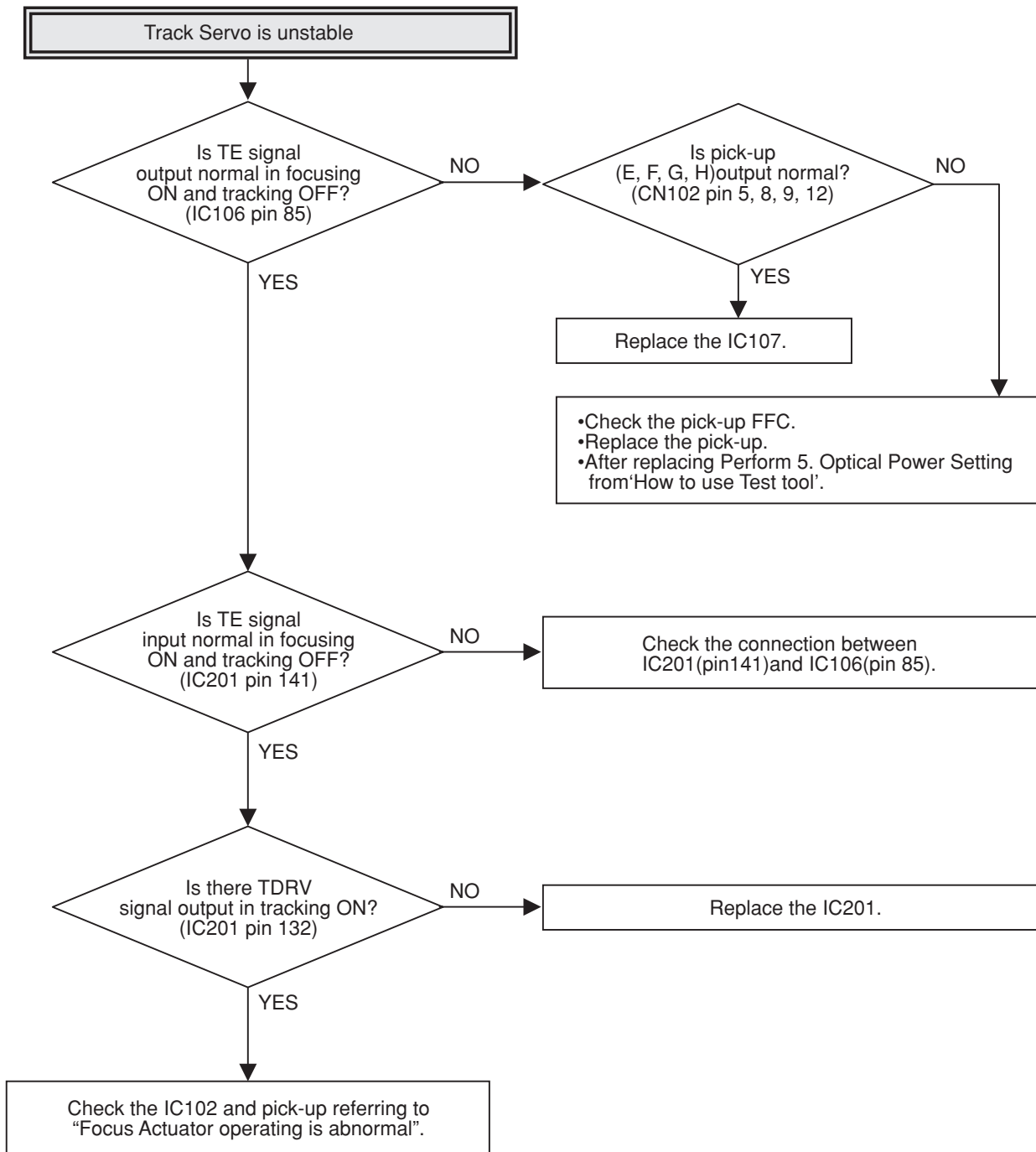

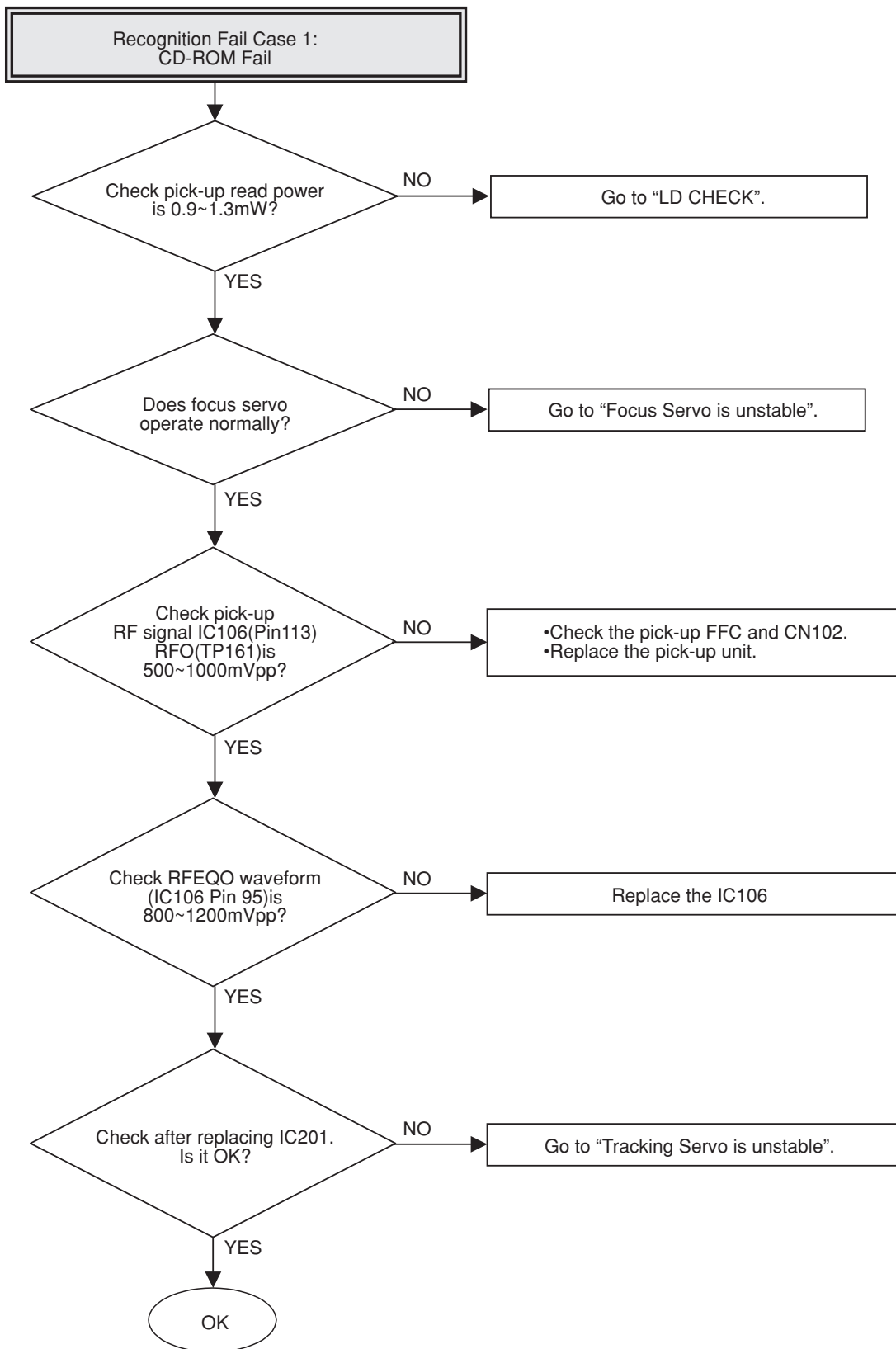

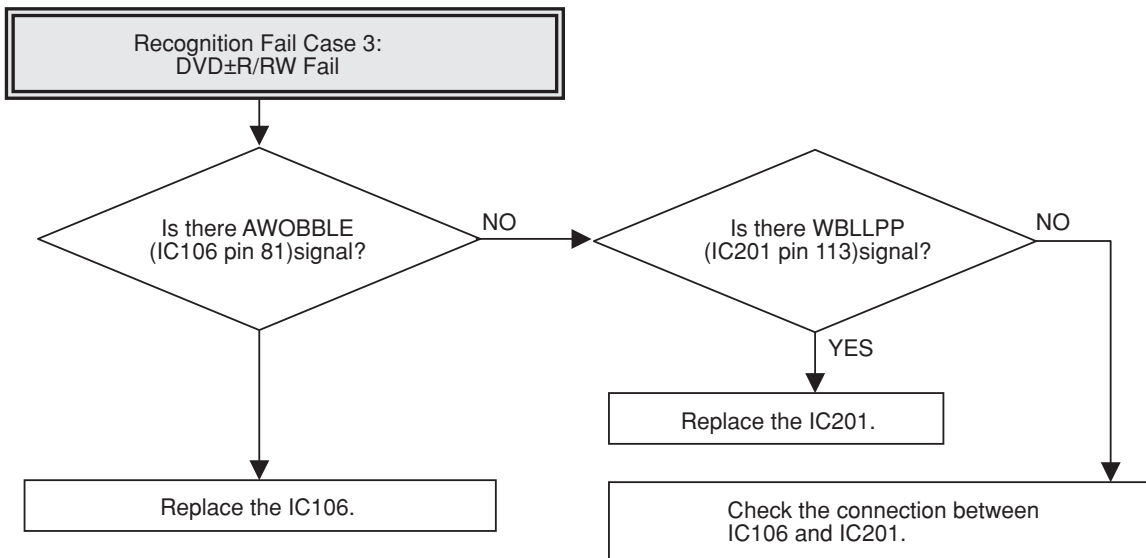
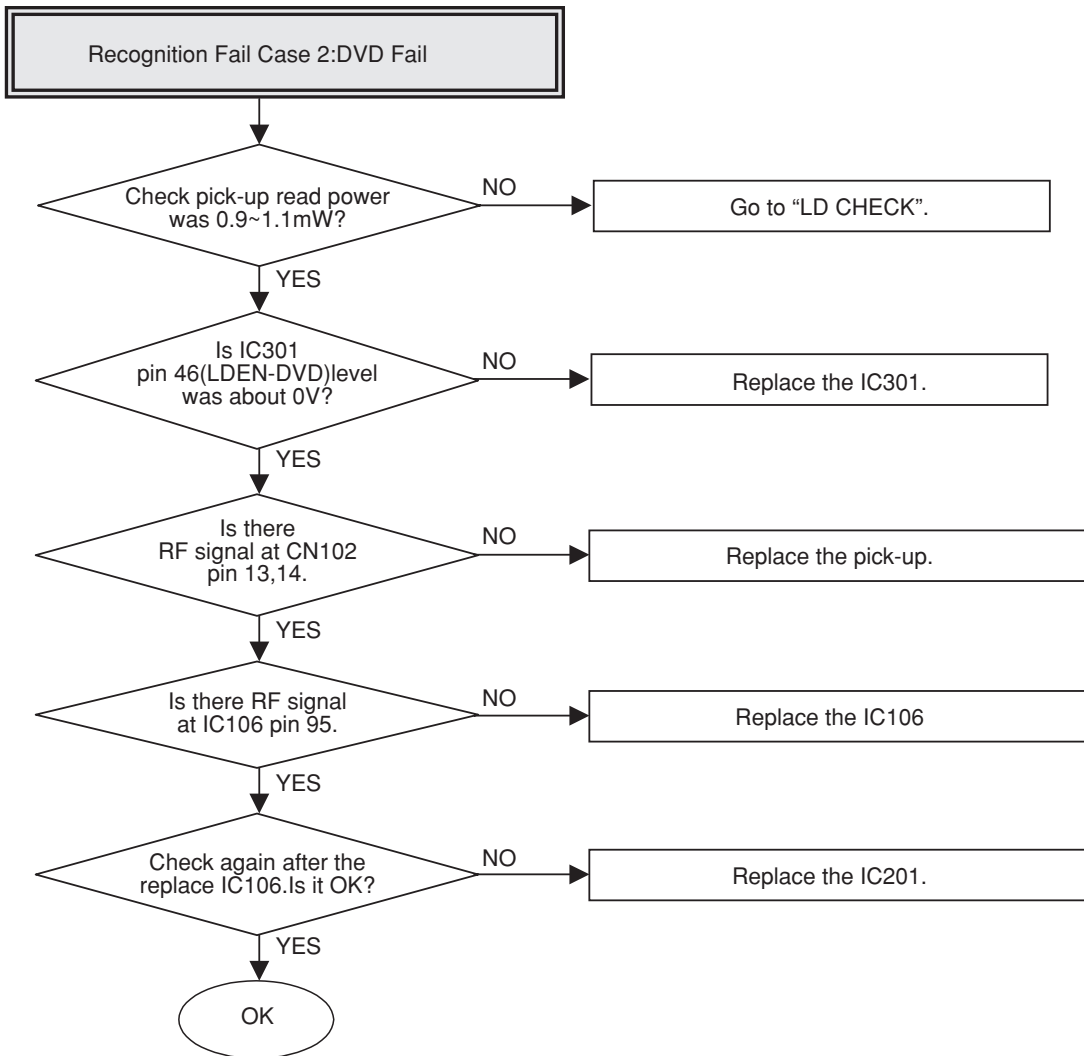

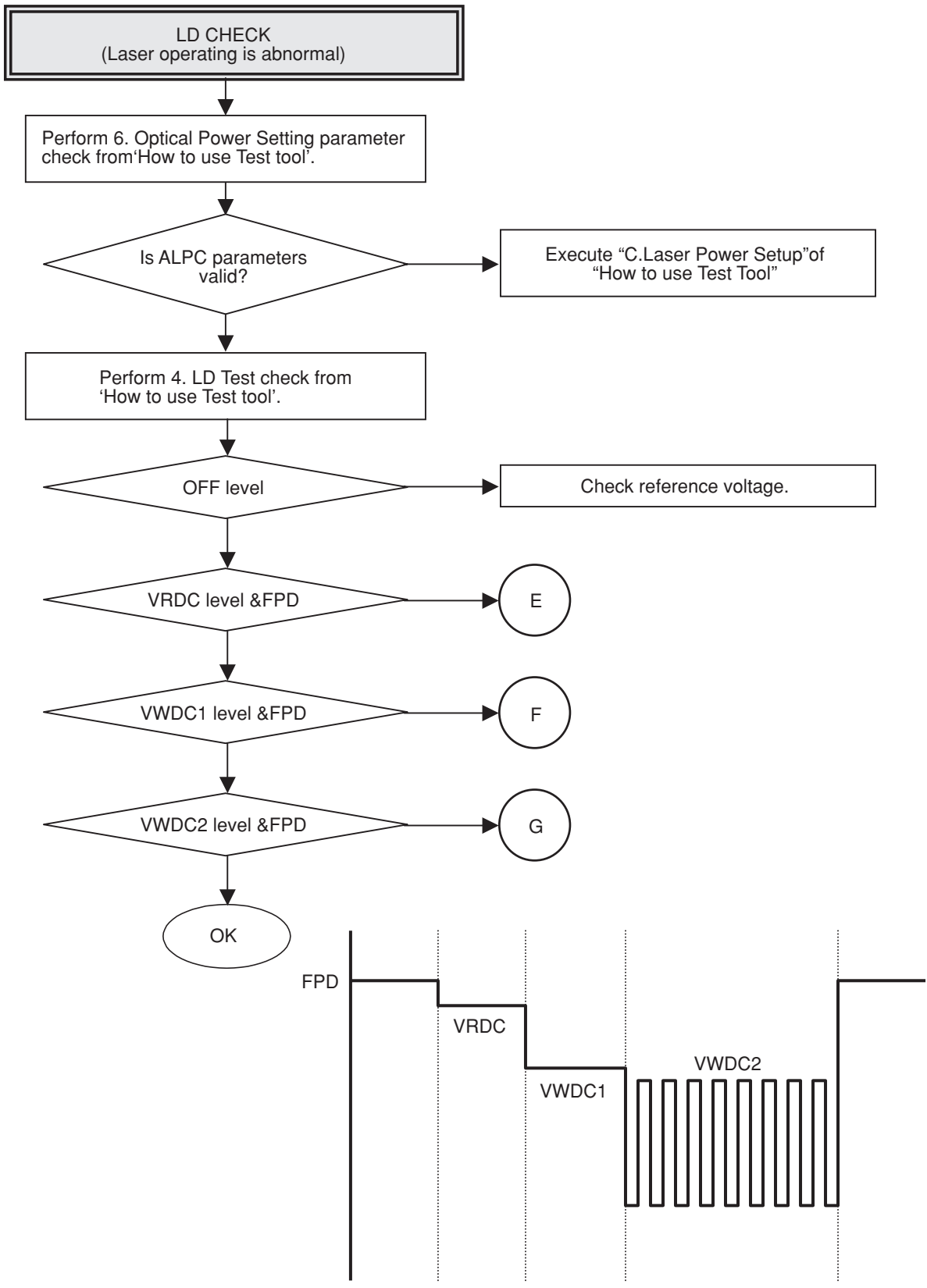

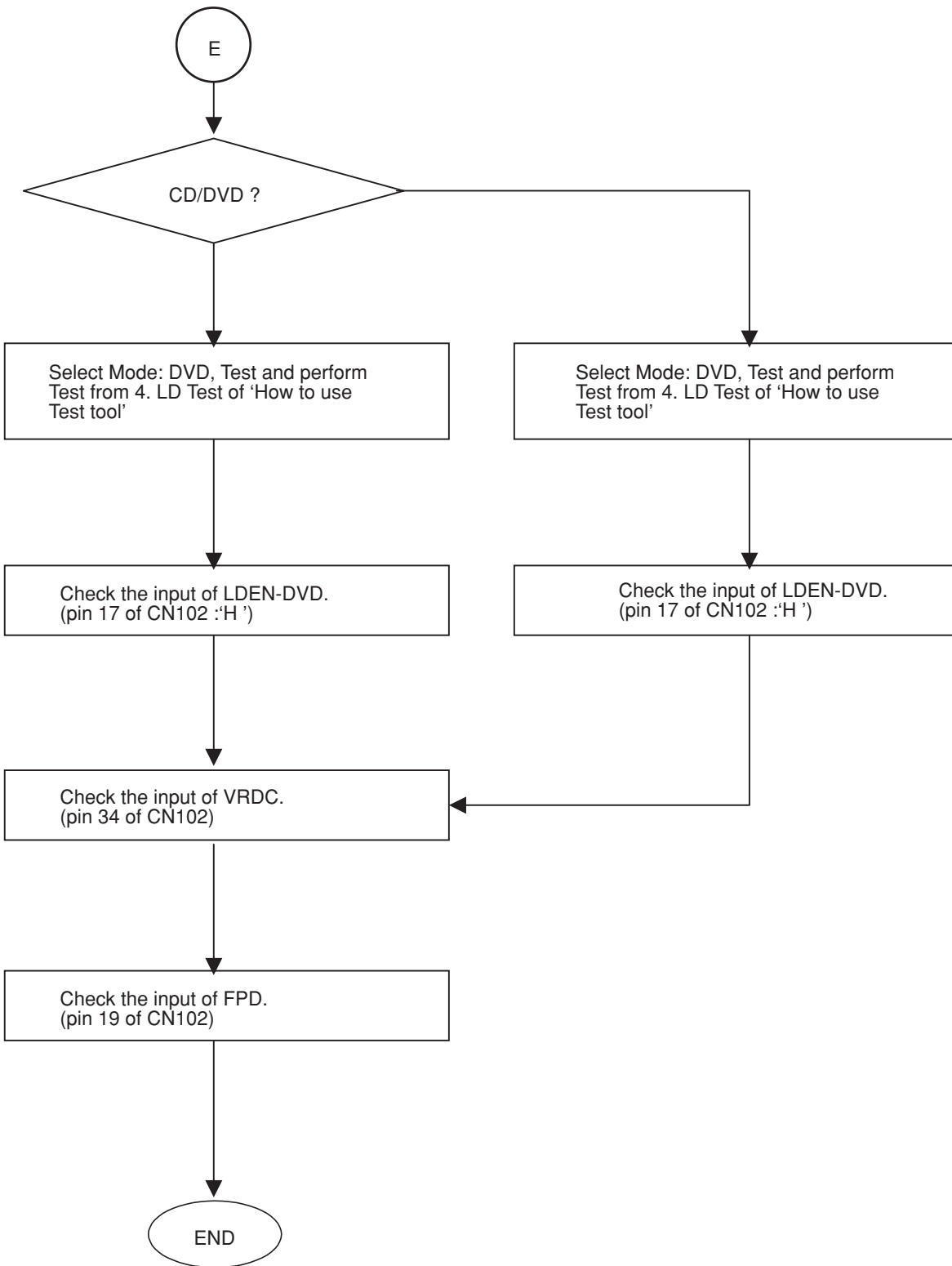

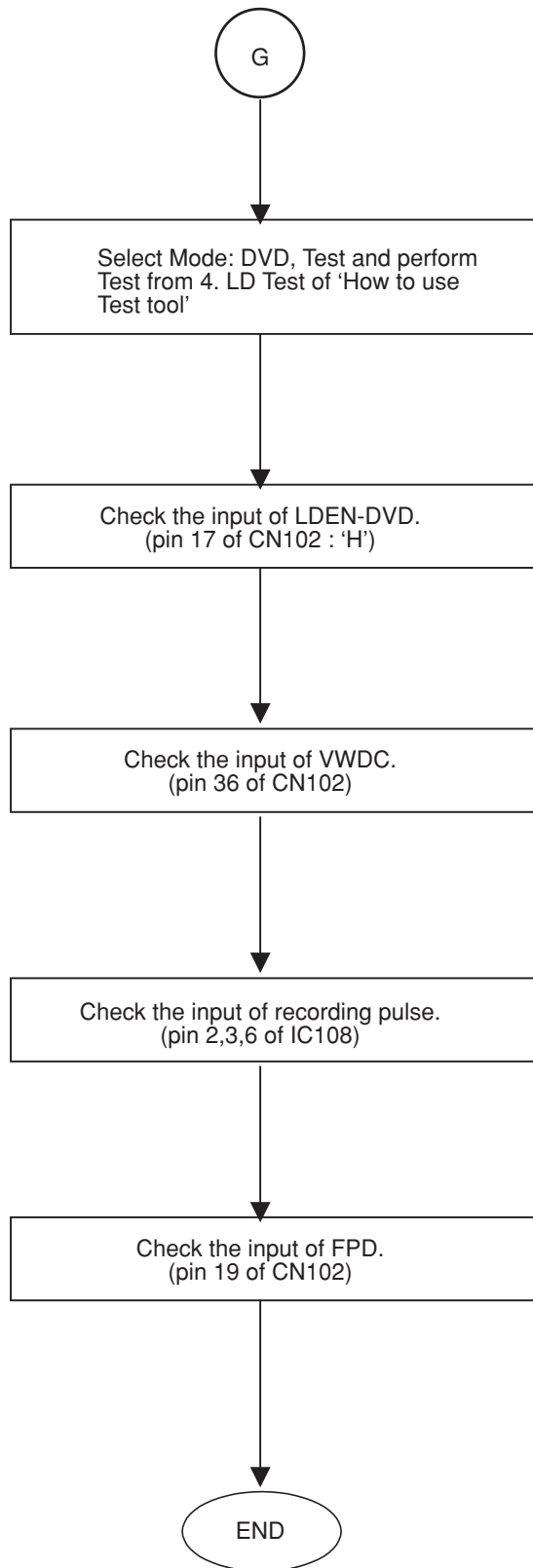
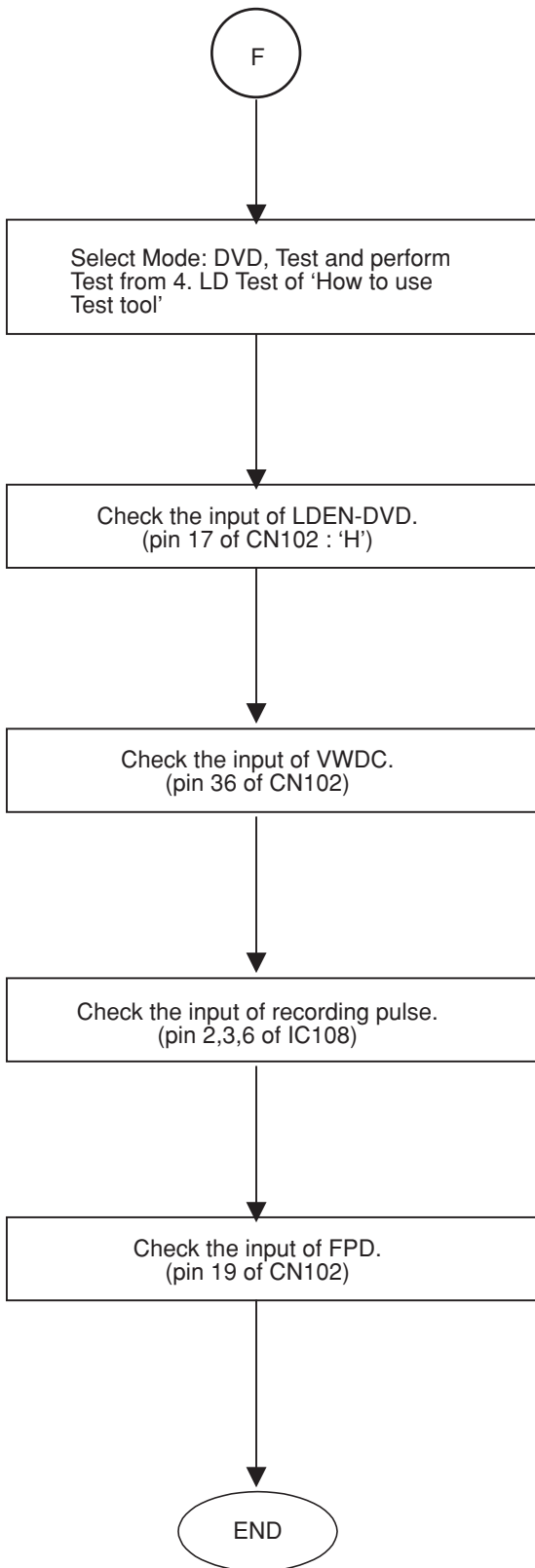

In case of writing fail.

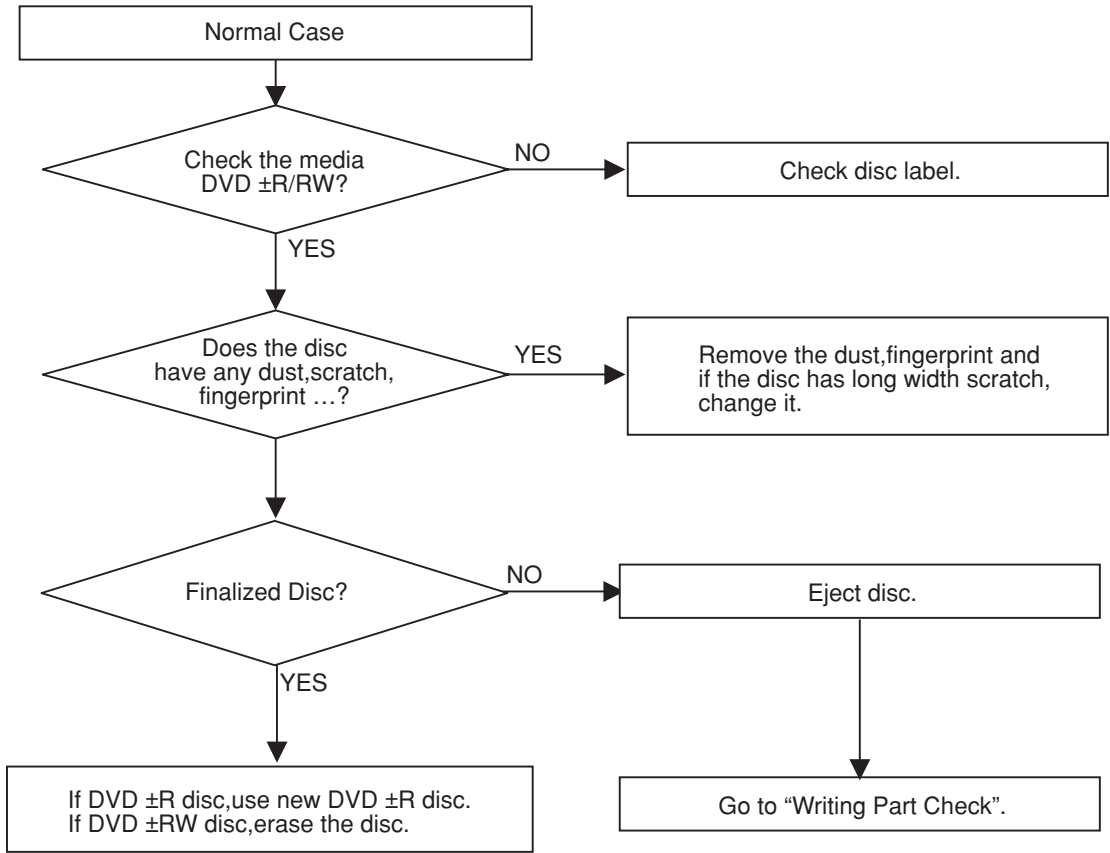

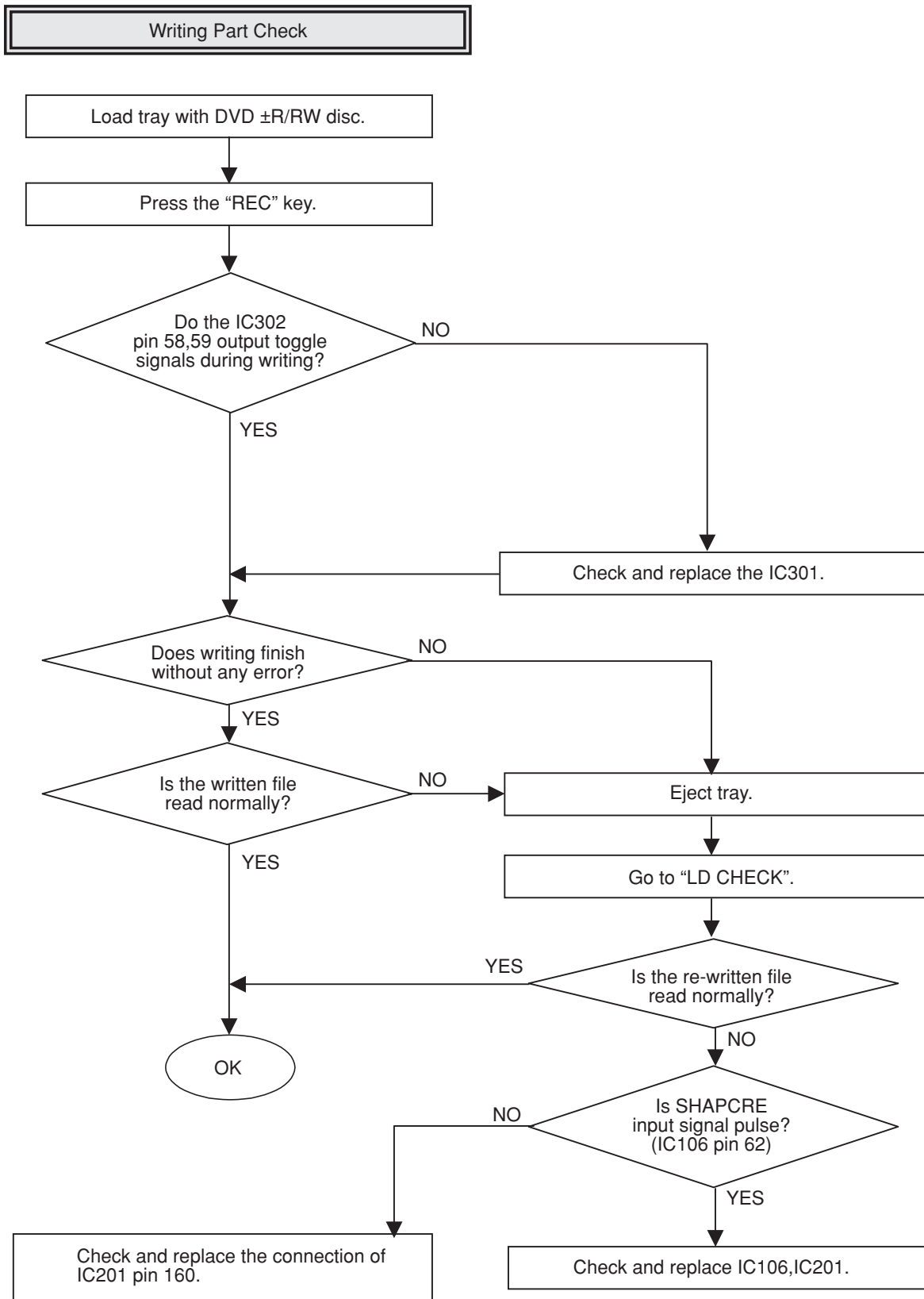

WAVEFORMS

1. POWER & RESET Signal

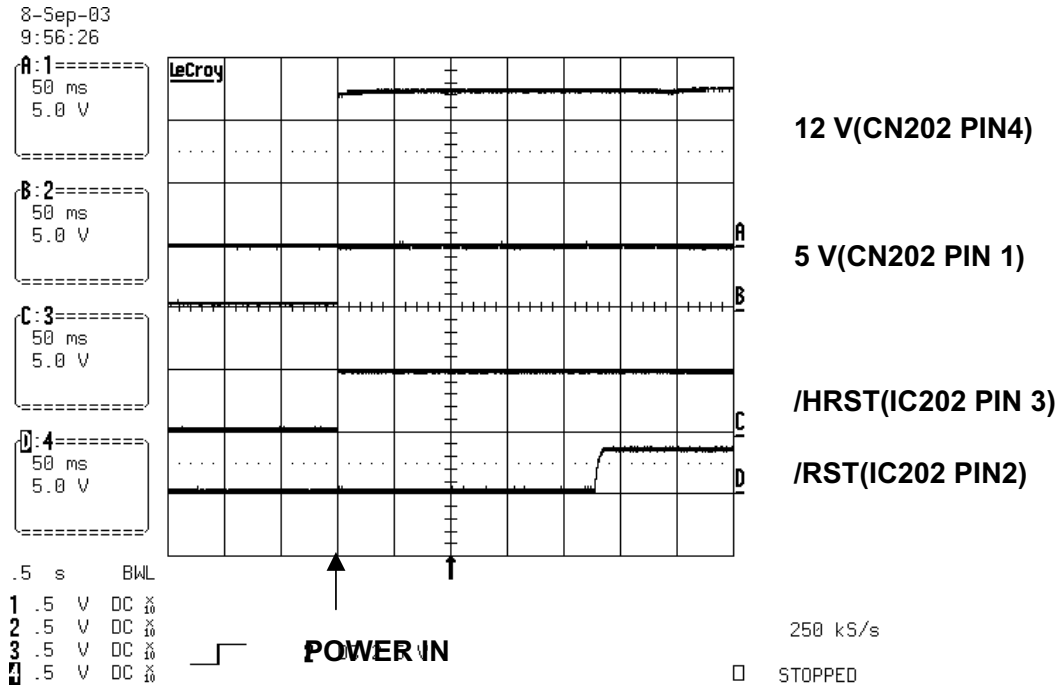

2. Main Clock1 for IC202 (16.9MHz)

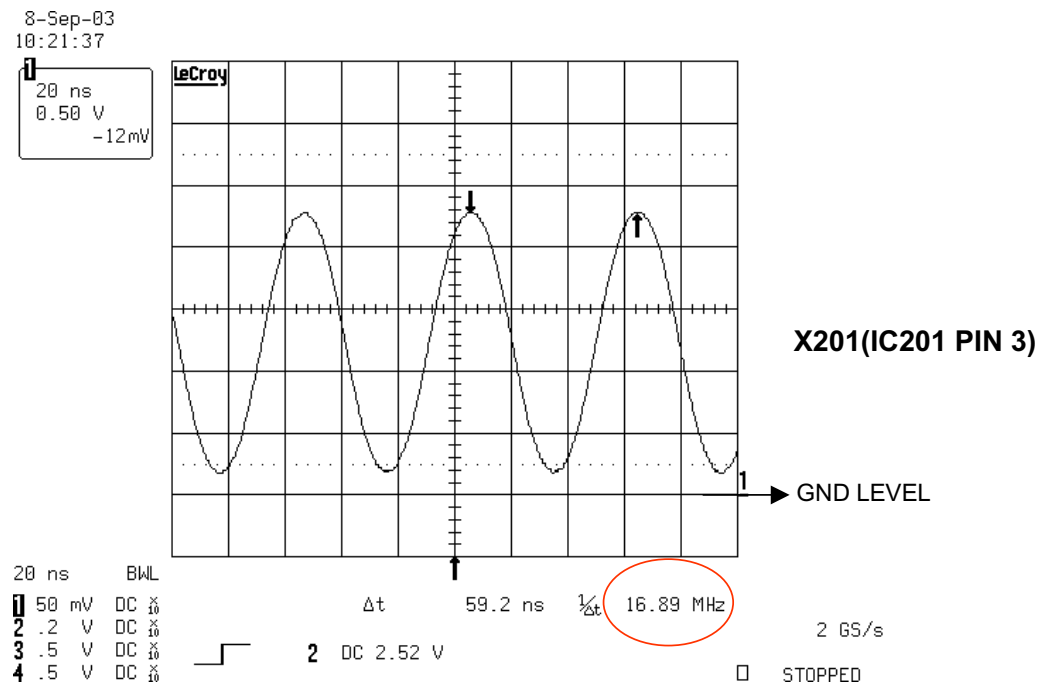

3. Main Clock2 for IC302 (20MHz)

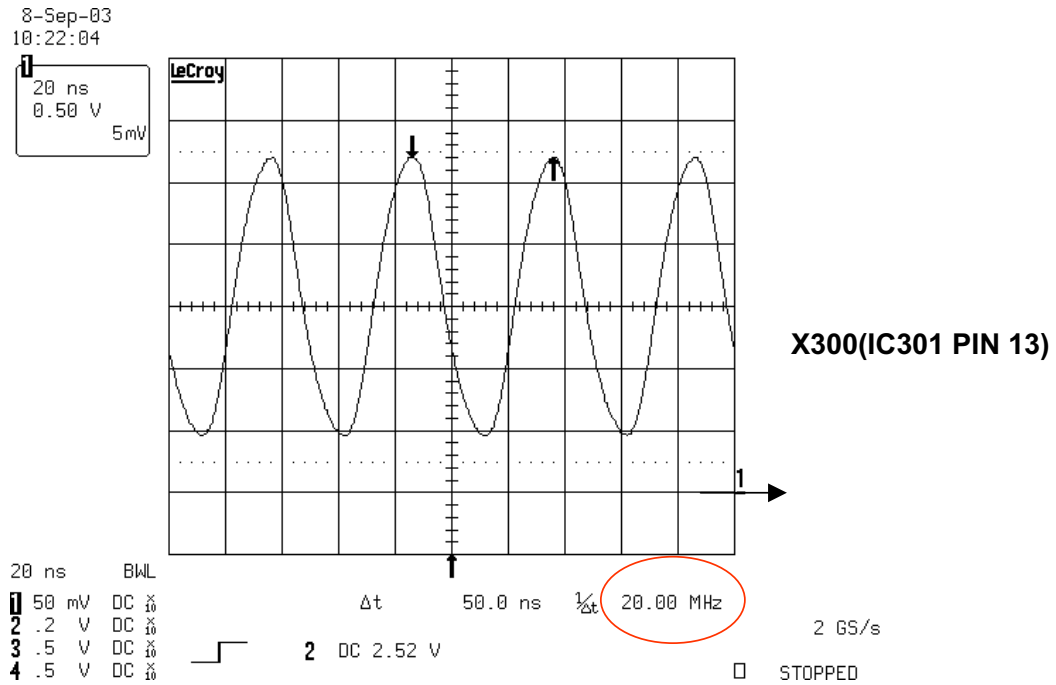

4. SDRAM Clock

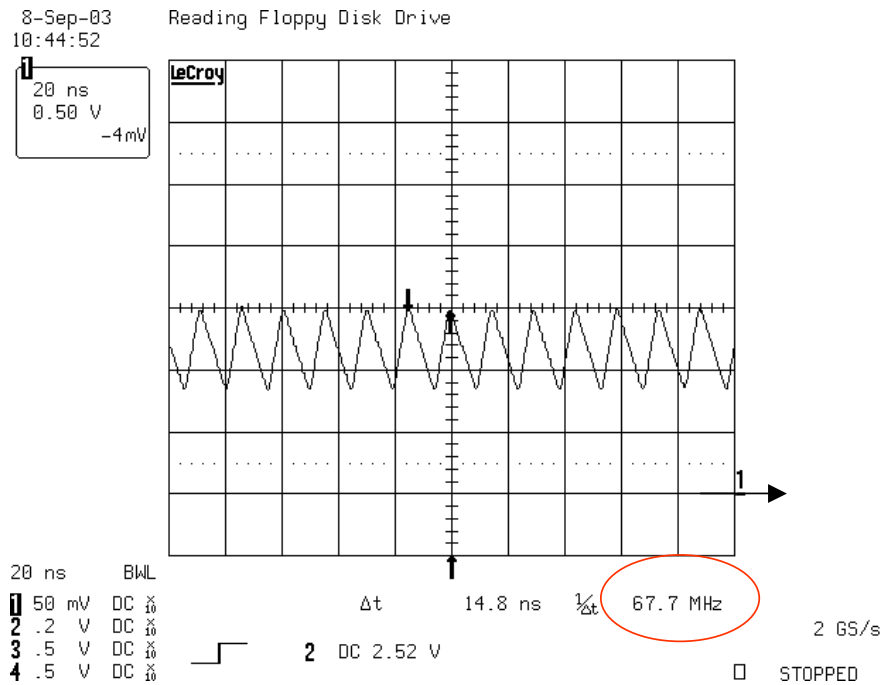

5. TRAY OPEN/CLOSE SIGNAL 1

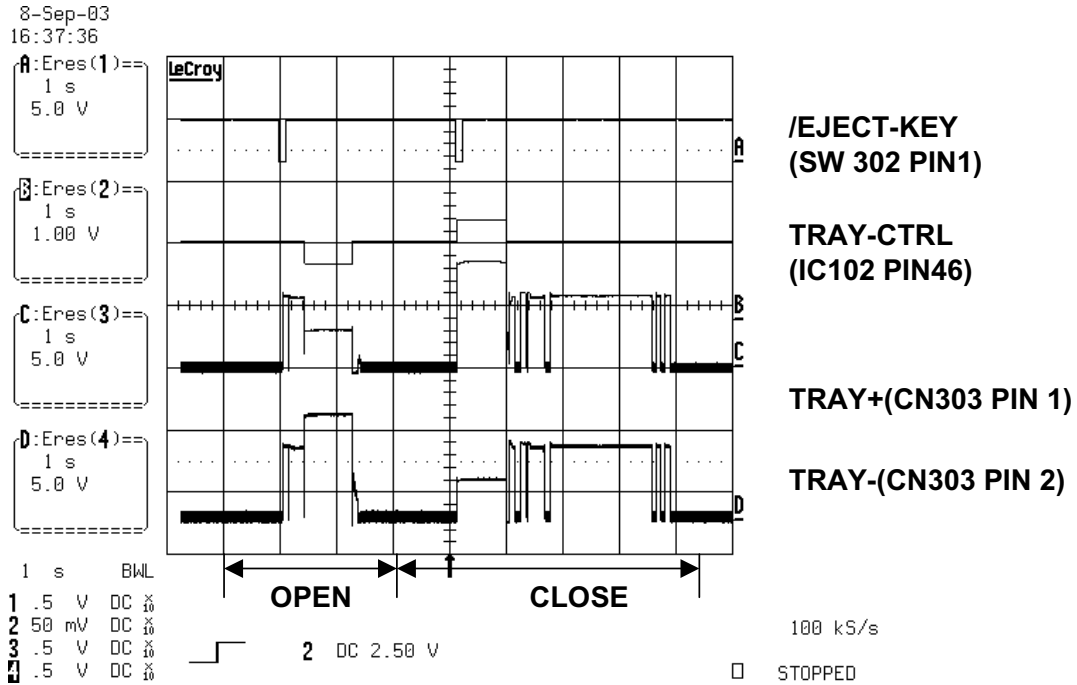

6. TRAY OPEN/CLOSE SIGNAL 2

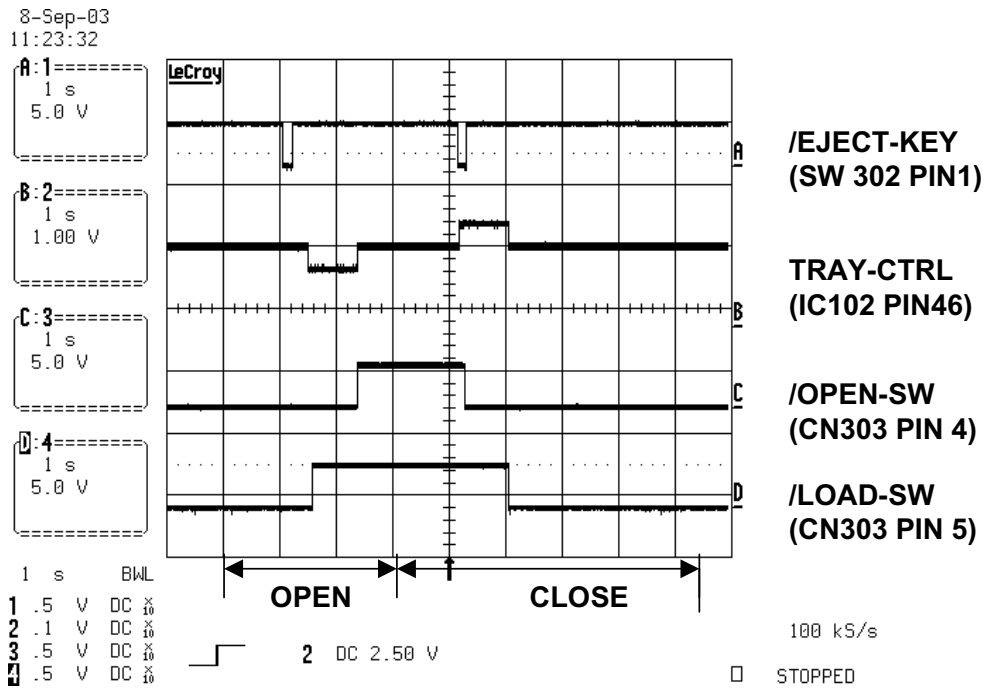

7. SLED MOVE SIGNAL 1

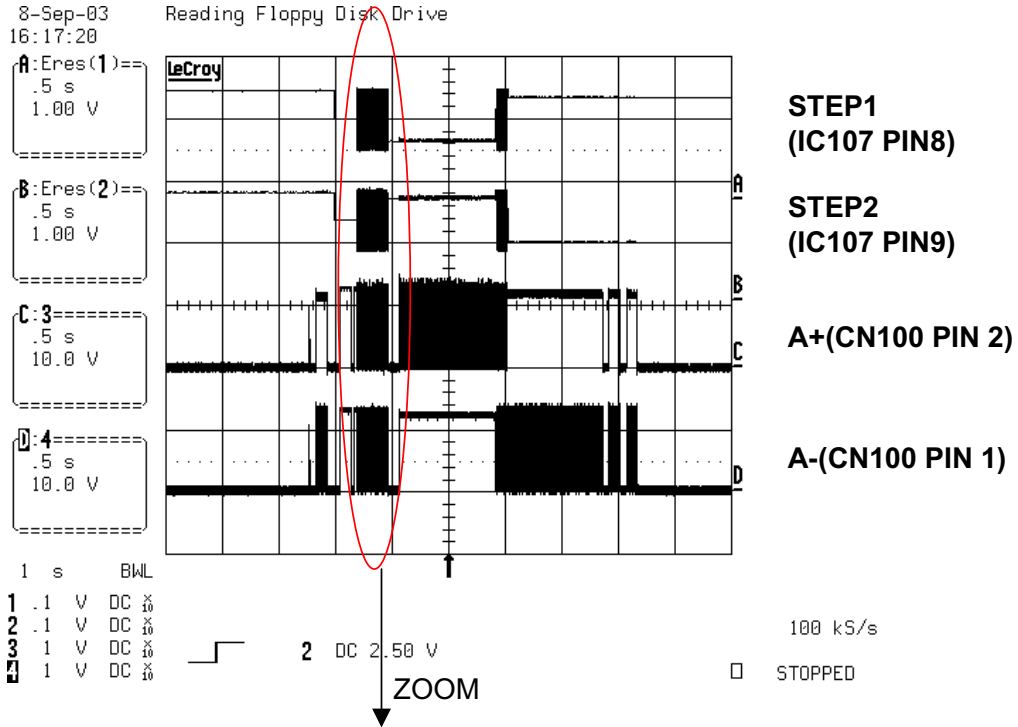

8. SLED MOVE SIGNAL 2

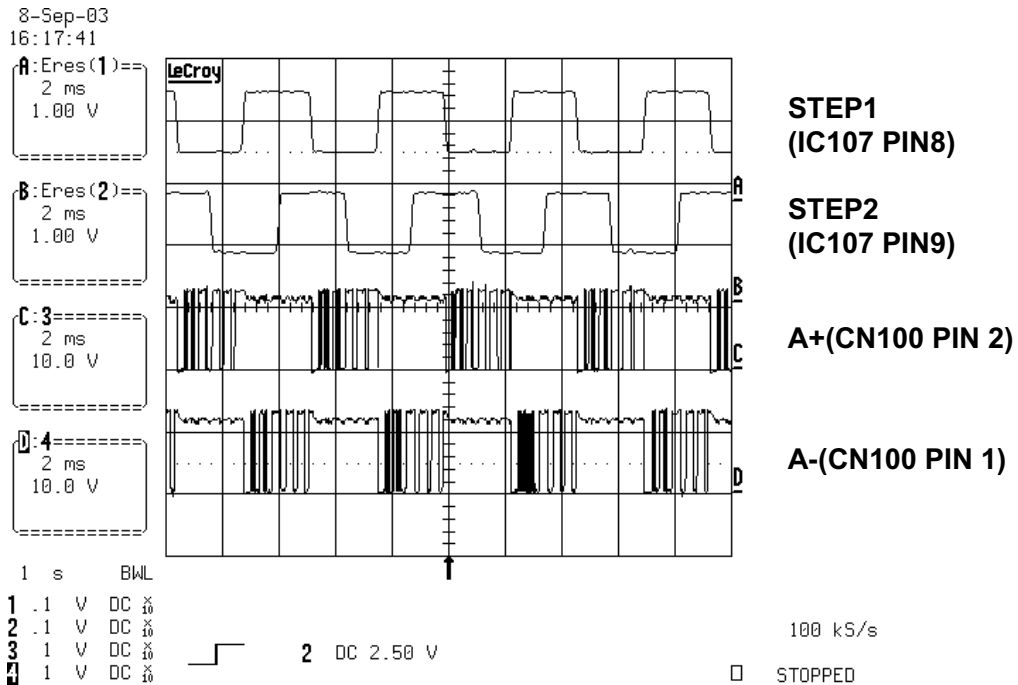

9. FOCUS SEARCH SIGNAL

8-Sep-03
15:55:44

A: Eres(1) ==
.2 s
200mV

B: Eres(2) ==
.2 s
0.50 V

C: Eres(3) ==
.2 s
0.50 V

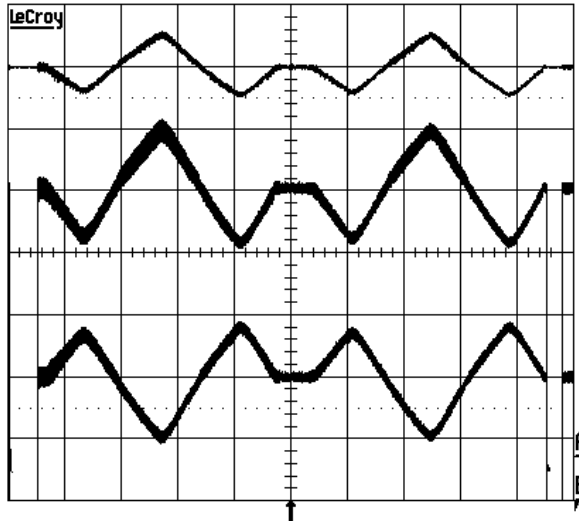

FDRV (IC104 PIN13)

F+ (IC102 PIN 52)

F- (IC102 PIN 51)

1 s BWL
1 20 mV DC $\times \frac{10}{10}$
2 50 mV DC $\times \frac{10}{10}$
3 50 mV DC $\times \frac{10}{10}$
4 .1 V DC $\times \frac{10}{10}$

2 DC 2.50 V

100 kS/s

STOPPED

10. LASER TURN ON SIGNAL

8-Sep-03
16:07:45

A: Eres(1) ==
.2 s
1.00 V

B: Eres(2) ==
.2 s
2.00 V

C: Eres(3) ==
.2 s
0.50 V

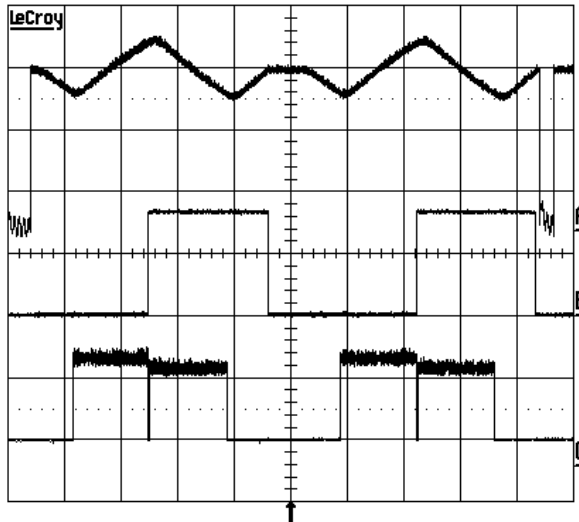

F+ (IC102 PIN 52)

LDEN-DVD(CN102 PIN17)

VRDC(CN102 PIN 34)

1 s BWL
1 .1 V DC $\times \frac{10}{10}$
2 .5 V DC $\times \frac{10}{10}$
3 50 mV DC $\times \frac{10}{10}$
4 .1 V DC $\times \frac{10}{10}$

2 DC 2.5 V

100 kS/s

STOPPED

11. DISC TYPE JUDGEMENT WAVEFORM (CD SERIES)

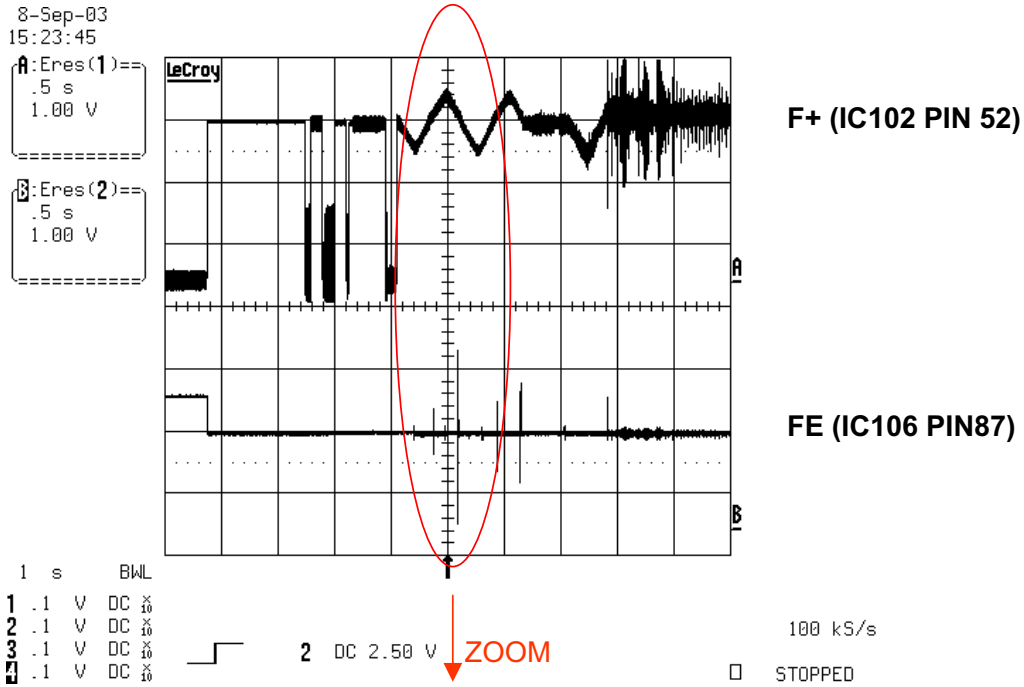

12. DISC TYPE JUDGEMENT WAVEFORM (CD&CD-R)

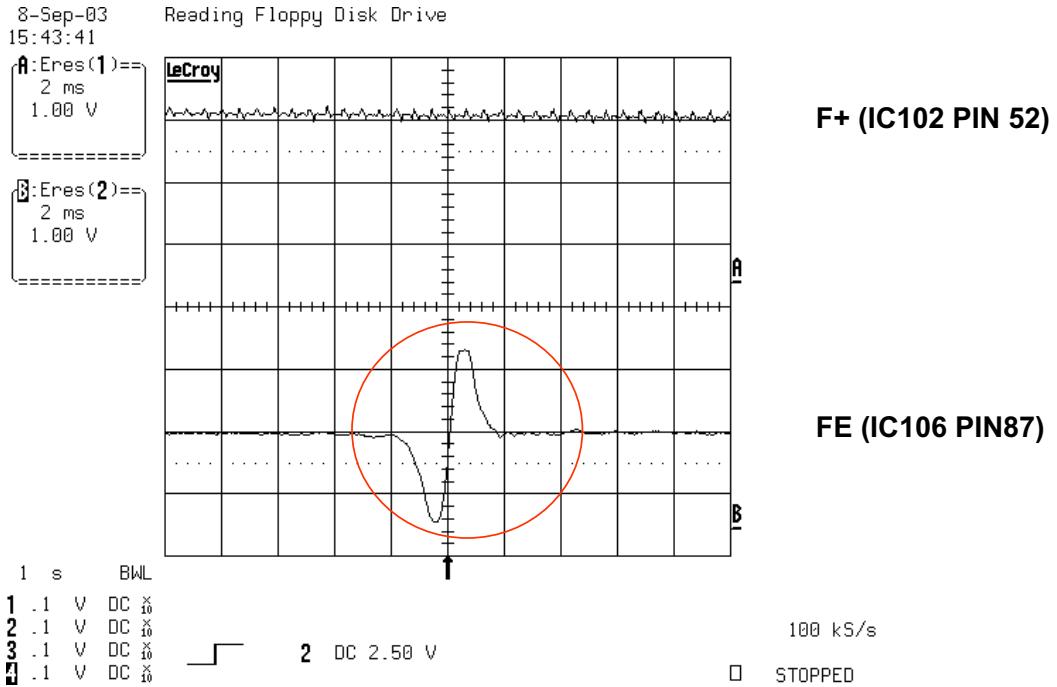

13. DISC TYPE JUDGEMENT WAVEFORM (CD-RW)

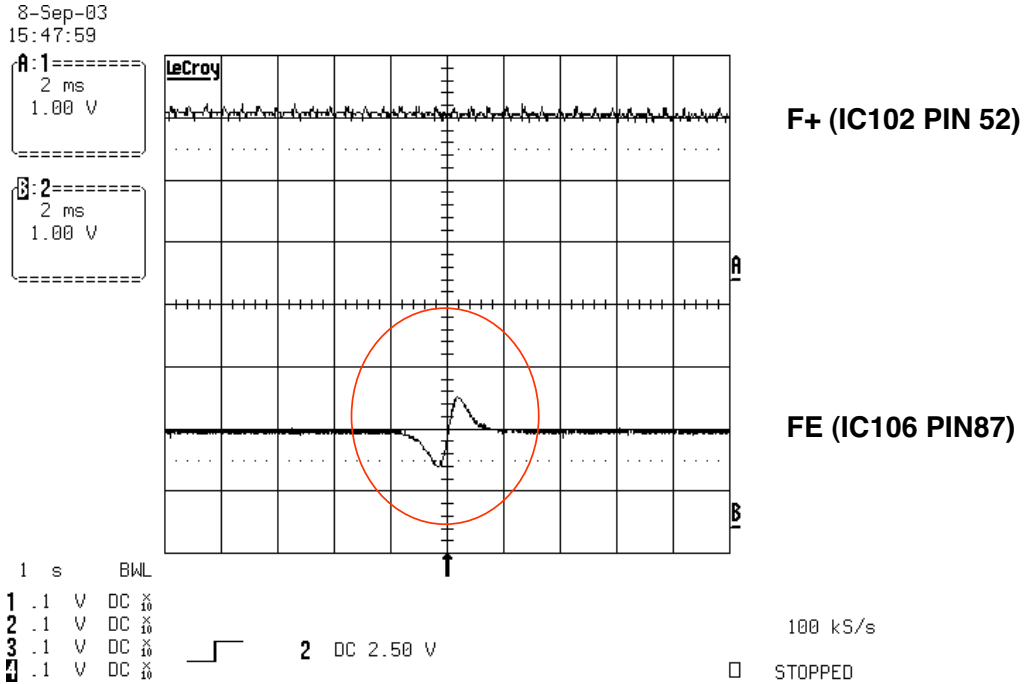

14. DISC TYPE JUDGEMENT WAVEFORM (DVD SERIES)

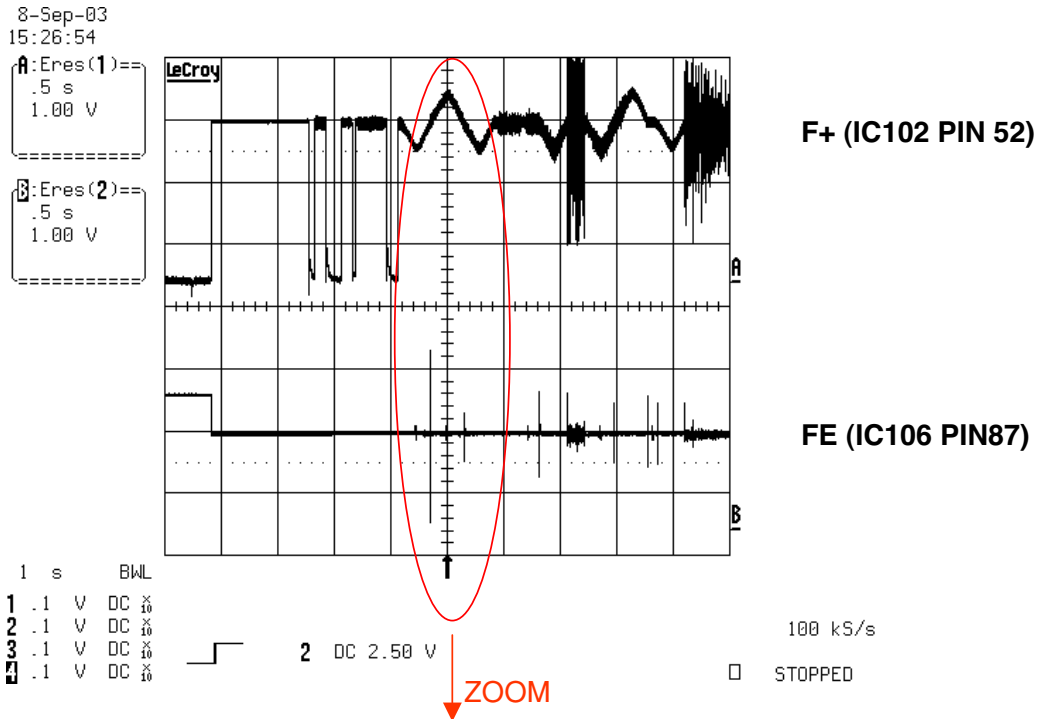

15. DISC TYPE JUDGEMENT WAVEFORM (DVD_SINGLE&R)

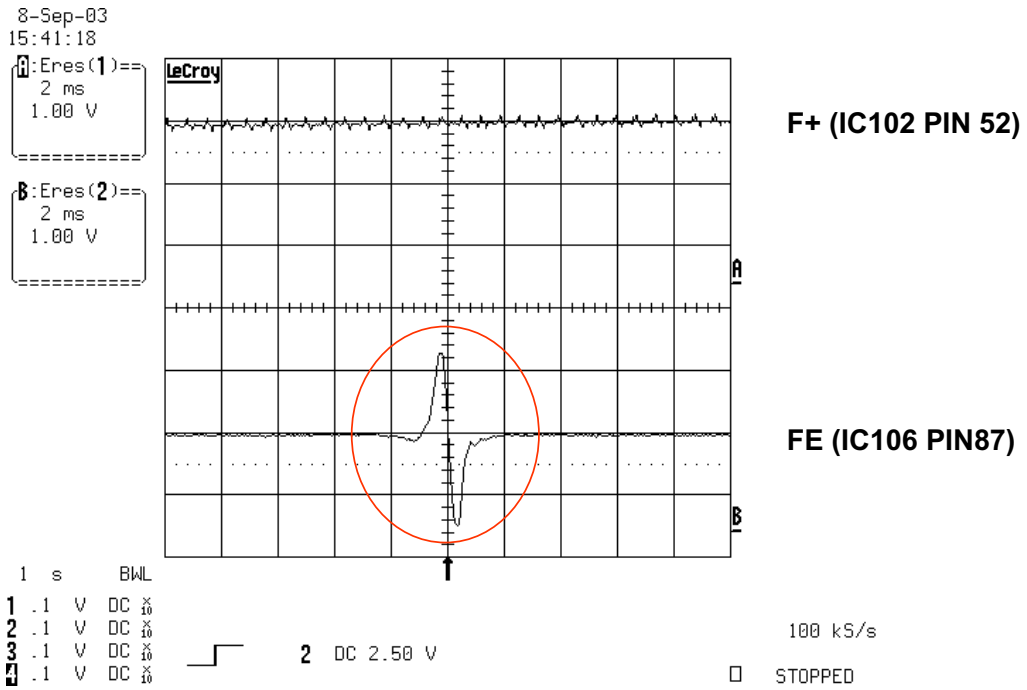

16. DISC TYPE JUDGEMENT WAVEFORM (DVD_DUAL)

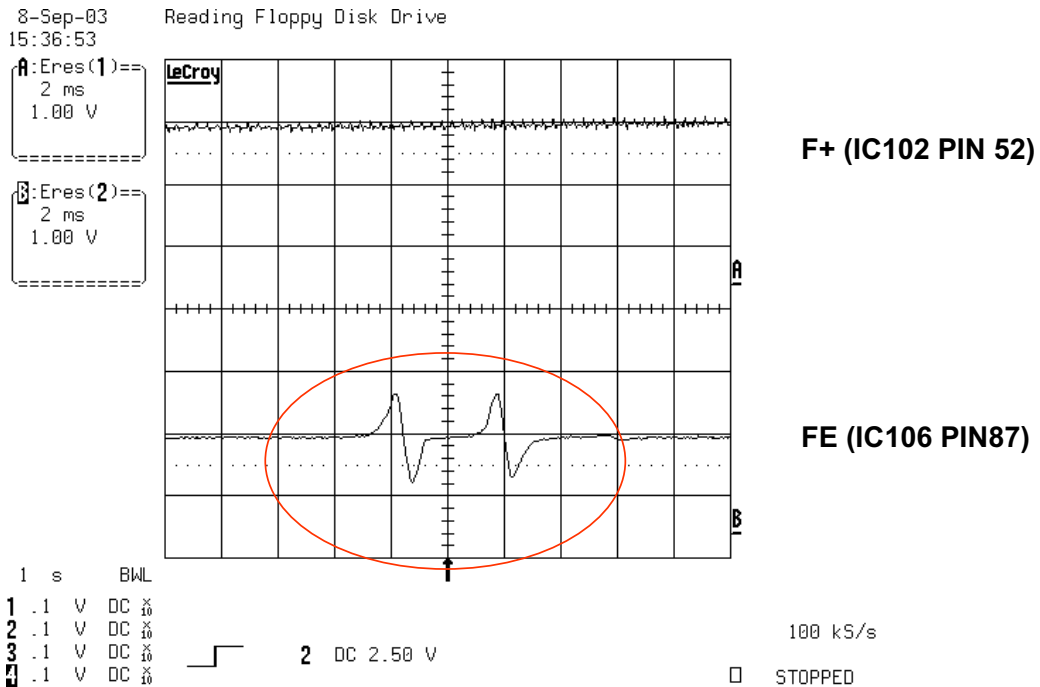

17. DISC TYPE JUDGEMENT WAVEFORM (DVDRW)

8-Sep-03
15:45:15

A: Eres(1) ==
2 ms
1.00 V

B: Eres(2) ==
2 ms
1.00 V

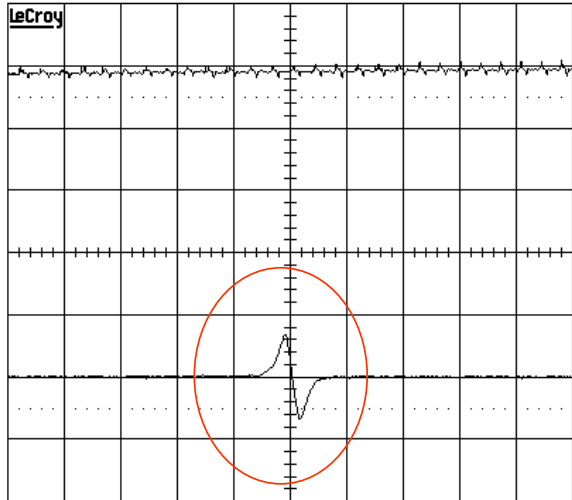

F+ (IC102 PIN 52)

FE (IC106 PIN87)

1 s BWL
1 .1 V DC $\times \frac{10}{10}$
2 .1 V DC $\times \frac{10}{10}$
3 .1 V DC $\times \frac{10}{10}$
4 .1 V DC $\times \frac{10}{10}$



2 DC 2.50 V

100 kS/s

STOPPED

18. SPINDLE WAVEFORM1

8-Sep-03
16:58:06

A: Eres(1) ==
.2 s
1.00 V

B: Eres(2) ==
.2 s
1.00 V

C: Eres(3) ==
.2 s
2.00 V

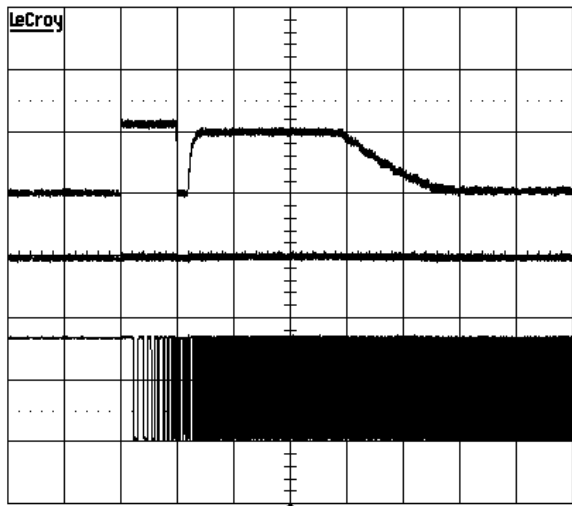

MDRV (IC104 PIN 9)

SRVC (IC104 PIN 10)

SFG((IC102 PIN43)

1 s BWL
1 .1 V DC $\times \frac{10}{10}$
2 .1 V DC $\times \frac{10}{10}$
3 .2 V DC $\times \frac{10}{10}$
4 .5 V DC $\times \frac{10}{10}$



2 DC 2.50 V

100 kS/s

STOPPED

19. SPINDLE WAVEFORM2

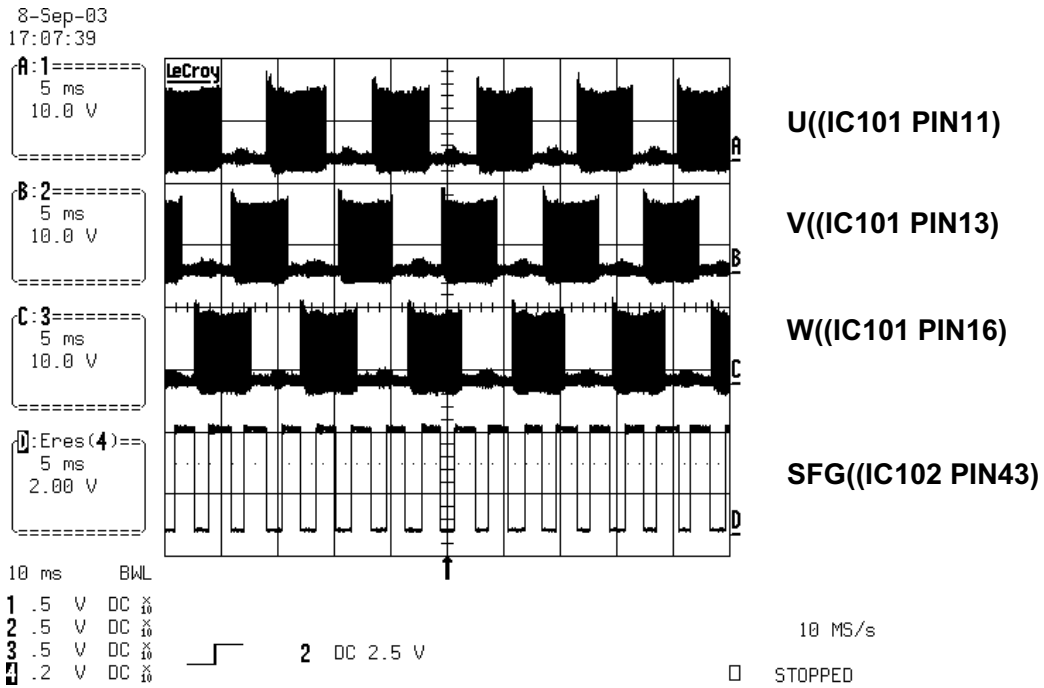

20. FOCUS ON SIGNAL(CD)

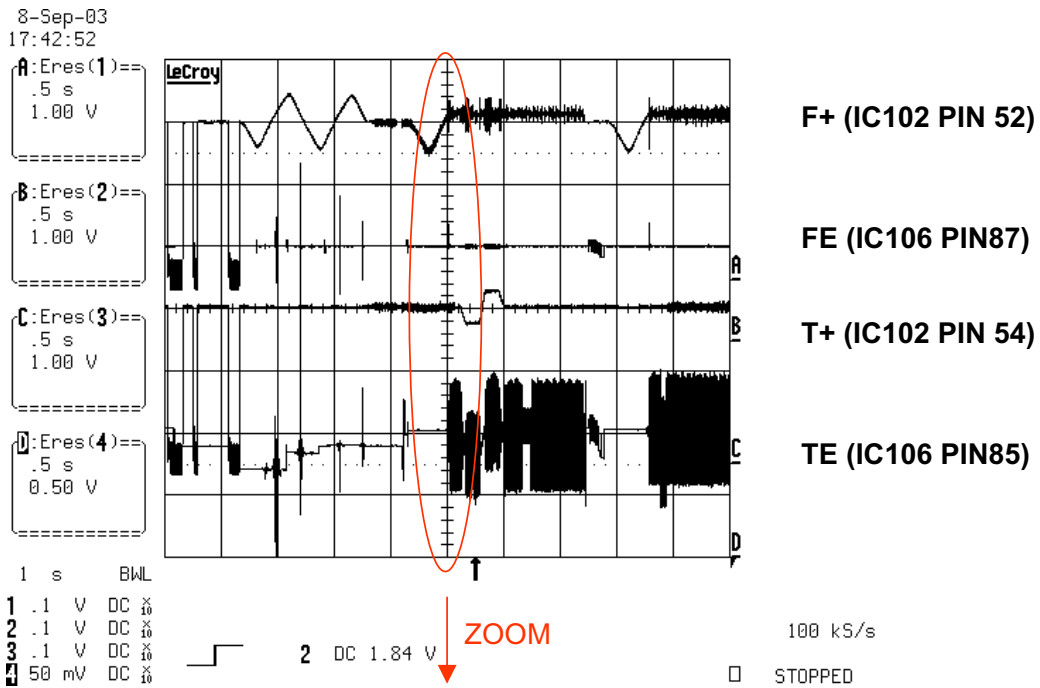

21. FOCUS ON SIGNAL(CD)

8-Sep-03
17:43:12

A: Eres(1) ==
5 ms
1.00 V

B: Eres(2) ==
5 ms
1.00 V

C: Eres(3) ==
5 ms
1.00 V

D: Eres(4) ==
5 ms
0.50 V

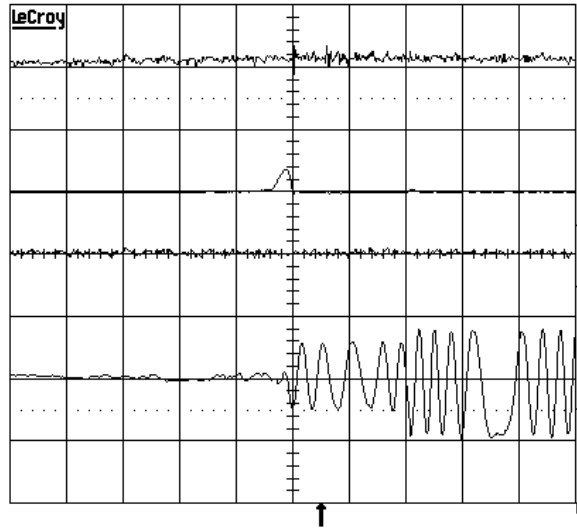

F+ (IC102 PIN 52)

FE (IC106 PIN87)

T+ (IC102 PIN 54)

TE (IC106 PIN85)

1 s BWL

1 .1 V DC

2 .1 V DC

3 .1 V DC

4 50 mV DC

2 DC 1.84 V

100 kS/s

STOPPED

22. FOCUS ON SIGNAL(DVD)

8-Sep-03
17:48:22

A: Eres(1) ==
.5 s
1.00 V

B: Eres(2) ==
.5 s
1.00 V

C: Eres(3) ==
.5 s
1.00 V

D: Eres(4) ==
.5 s
0.50 V

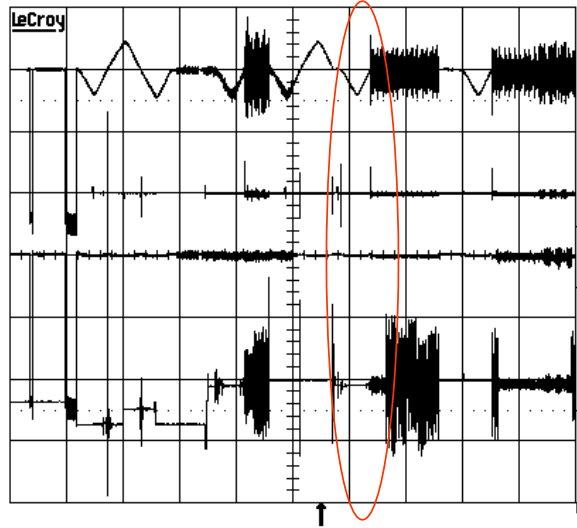

F+ (IC102 PIN 52)

FE (IC106 PIN87)

T+ (IC102 PIN 54)

TE (IC106 PIN85)

1 s BWL

1 .1 V DC

2 .1 V DC

3 .1 V DC

4 50 mV DC

2 DC 1.84 V

ZOOM

100 kS/s

STOPPED

23. FOCUS ON SIGNAL (DVD)

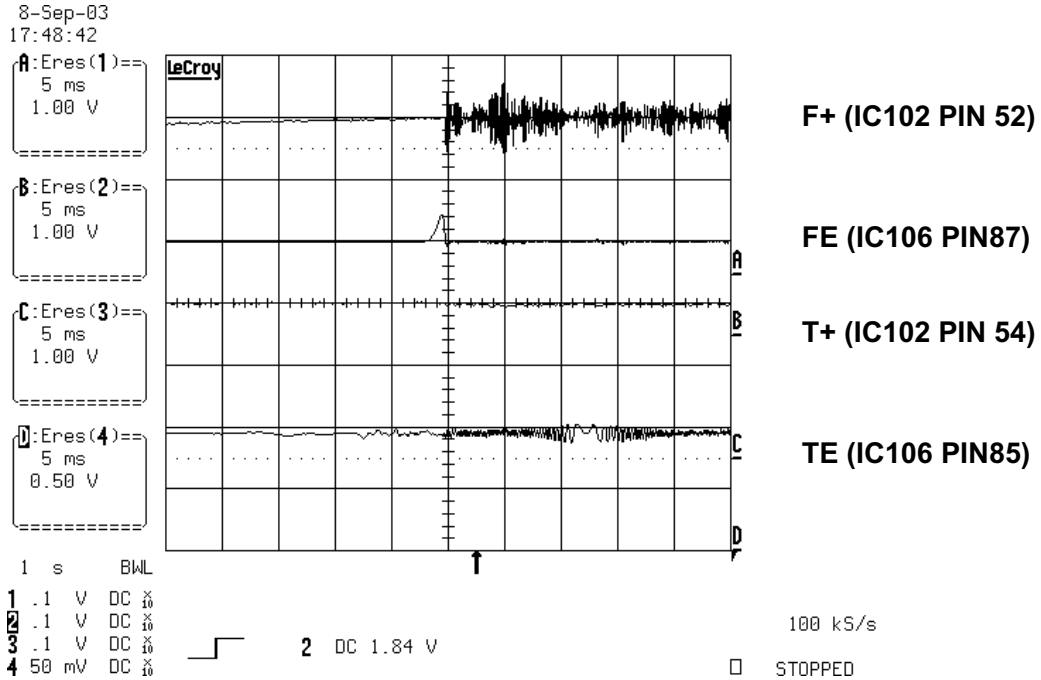

24. TRACK OFF SIGNAL(CD)

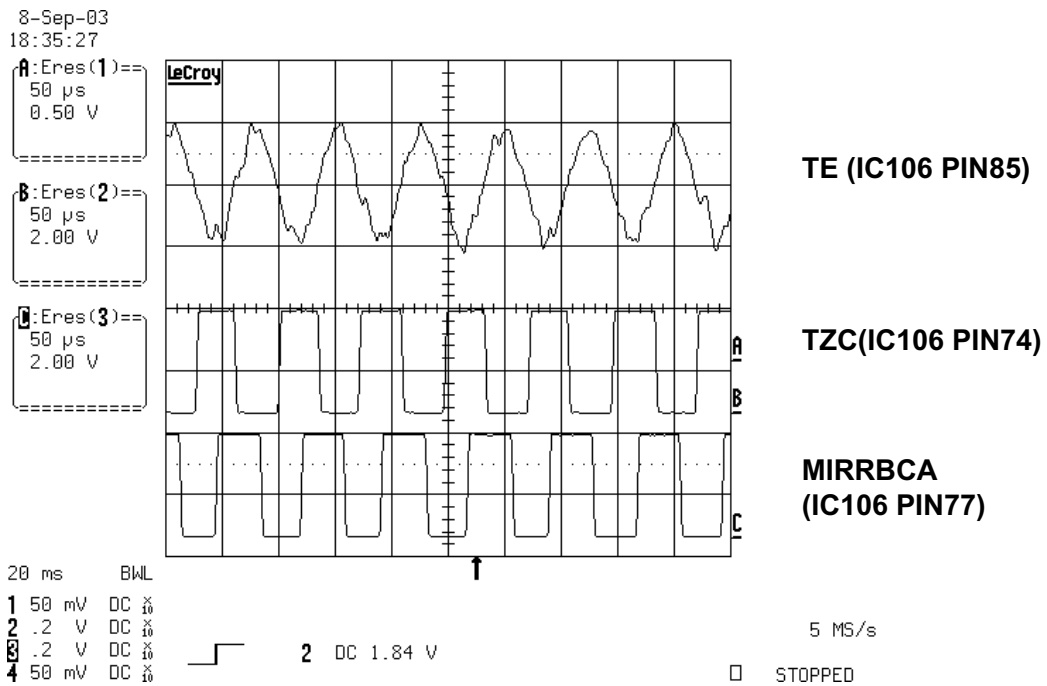

25. TRACK OFF SIGNAL(DVD)

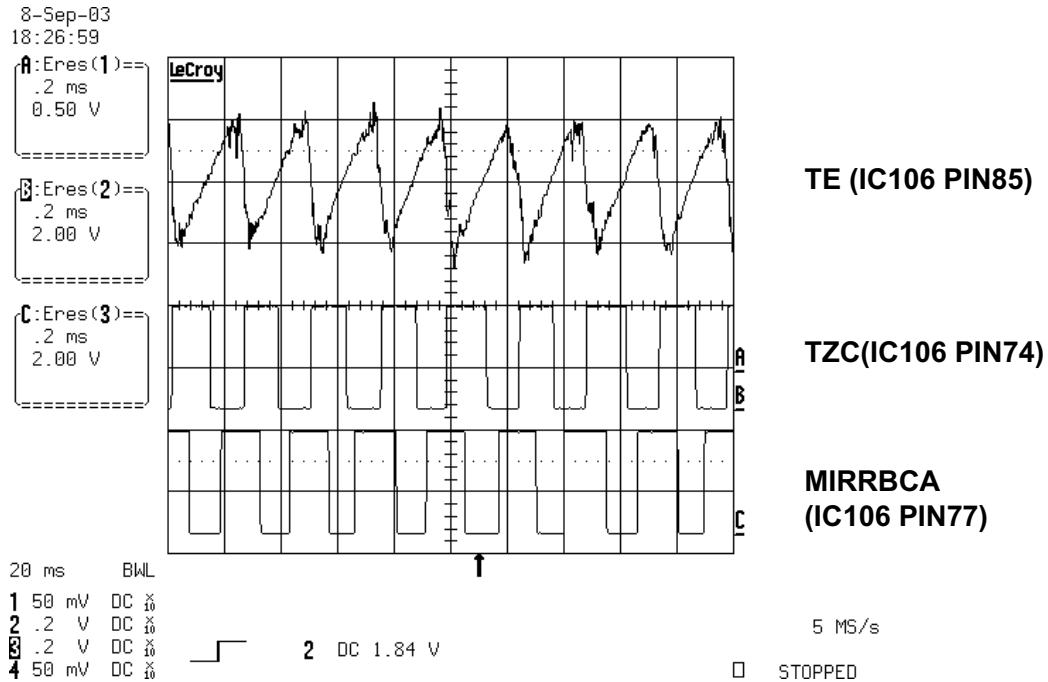

26. Tilt Driver signal(Disc reading)

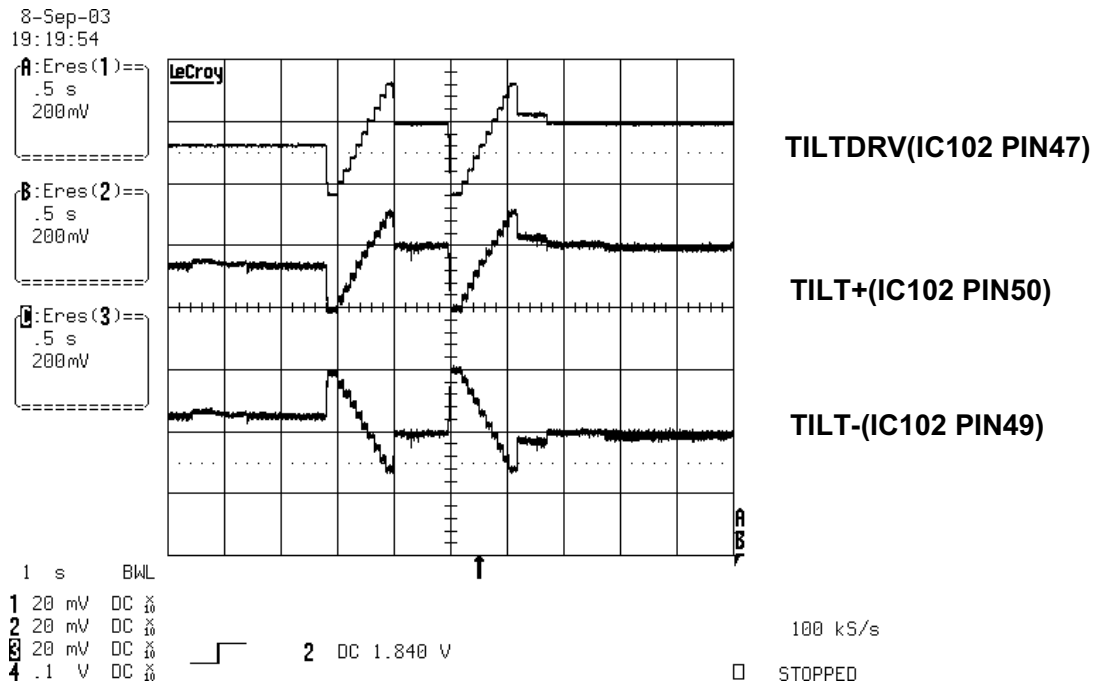

27. RF WAVEFORM(DVD)

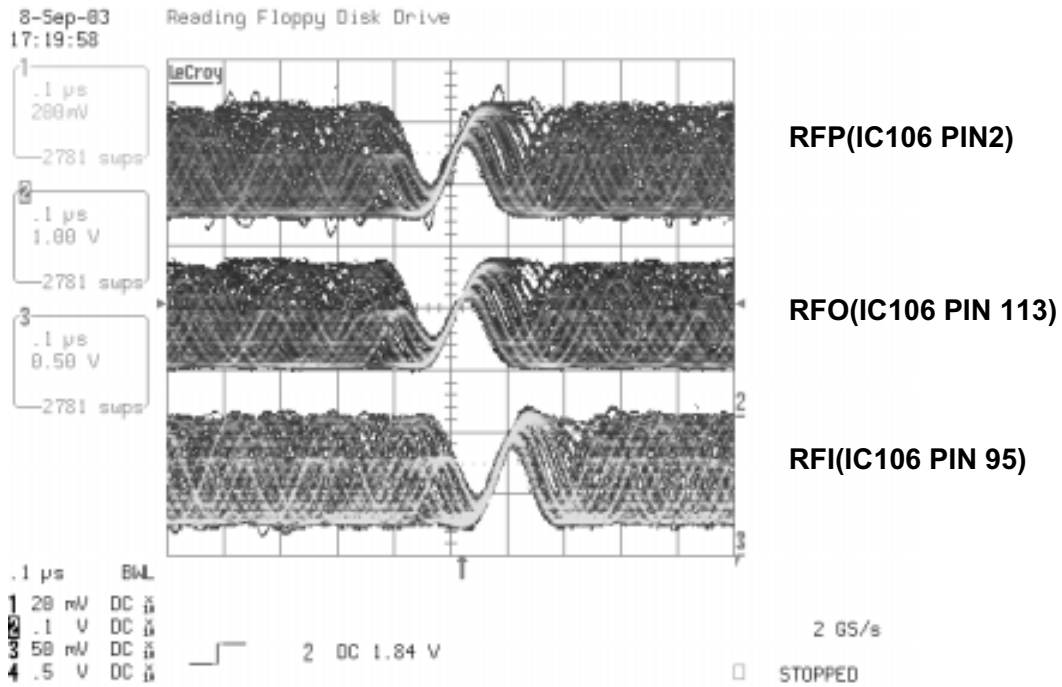

28. RF WAVEFORM(CD)

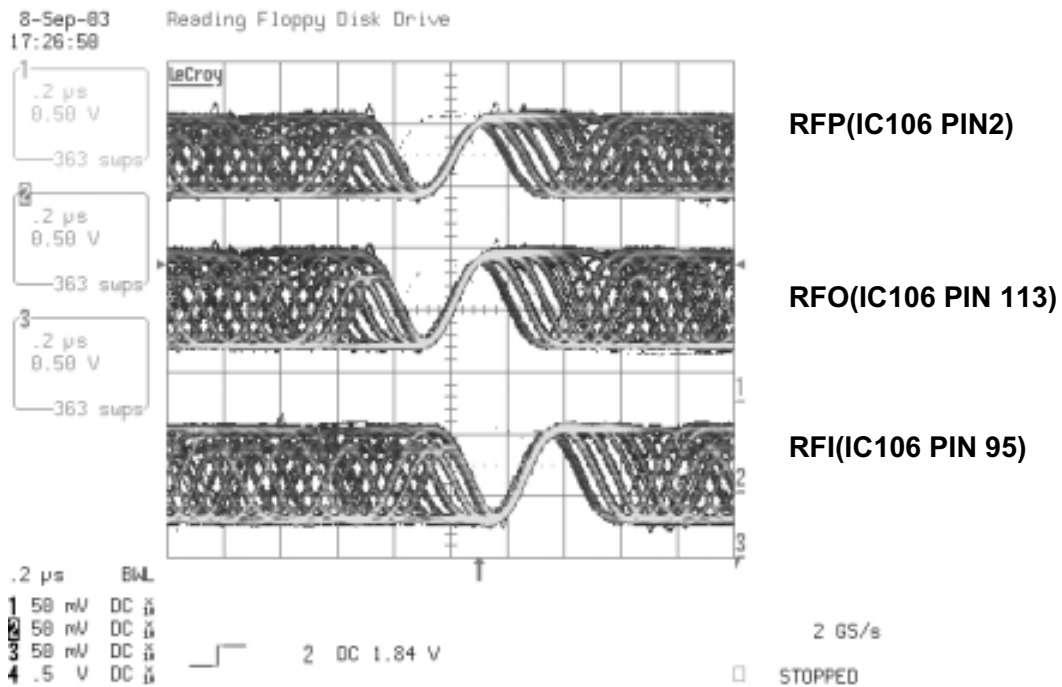

29. WOBBLE(DVD-R/RW)_READING

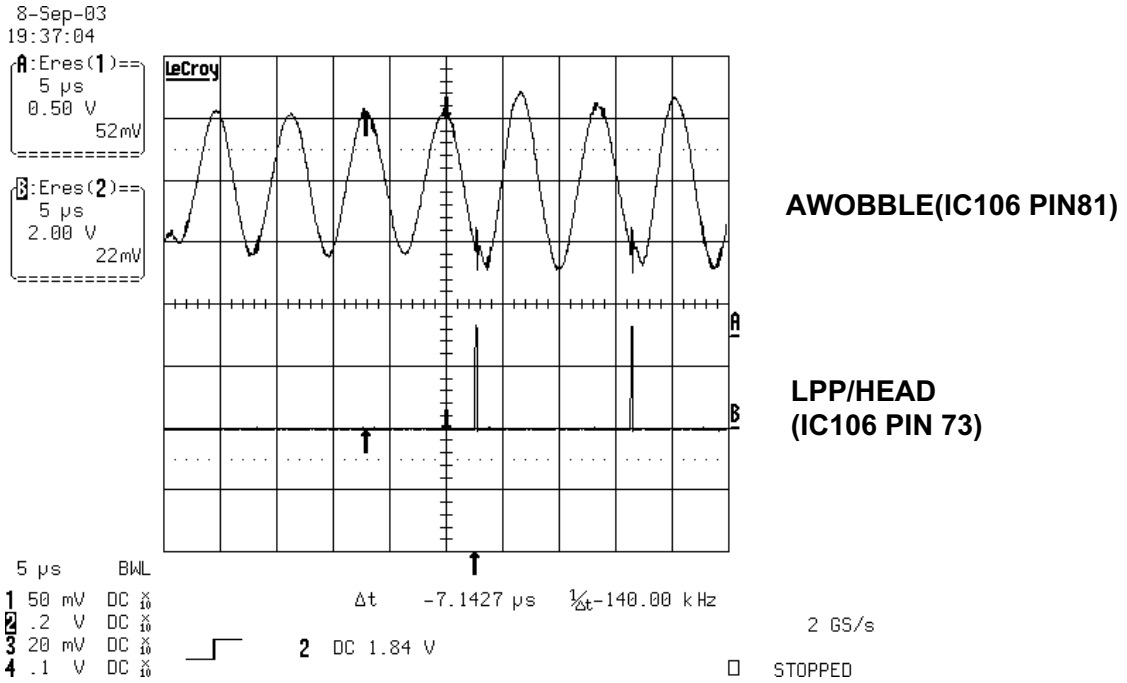

30. WOBBLE(DVD+R/RW)_READING&WRITING =>X1 SPEED

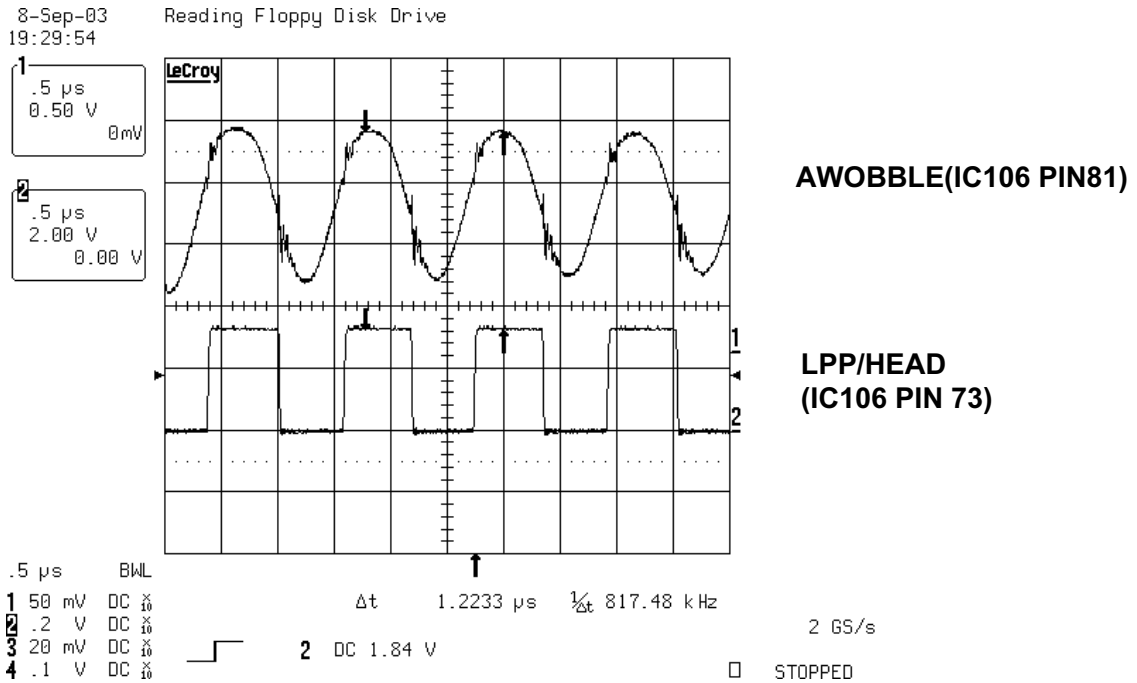

31. LD Enable(DVD)

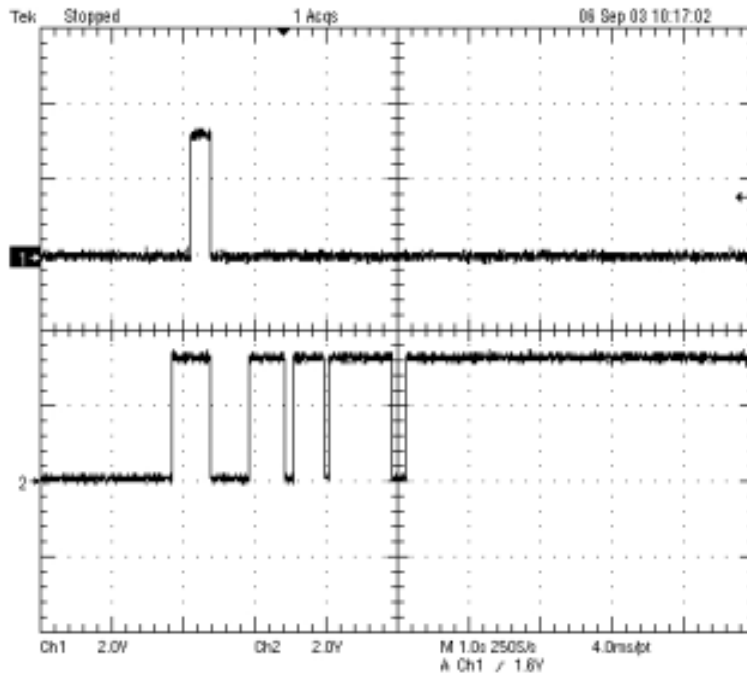

**LDENDVD
(CN102 PIN 17)**

**LDENC
(CN102 PIN 38)**

32. LD Enable(CD)

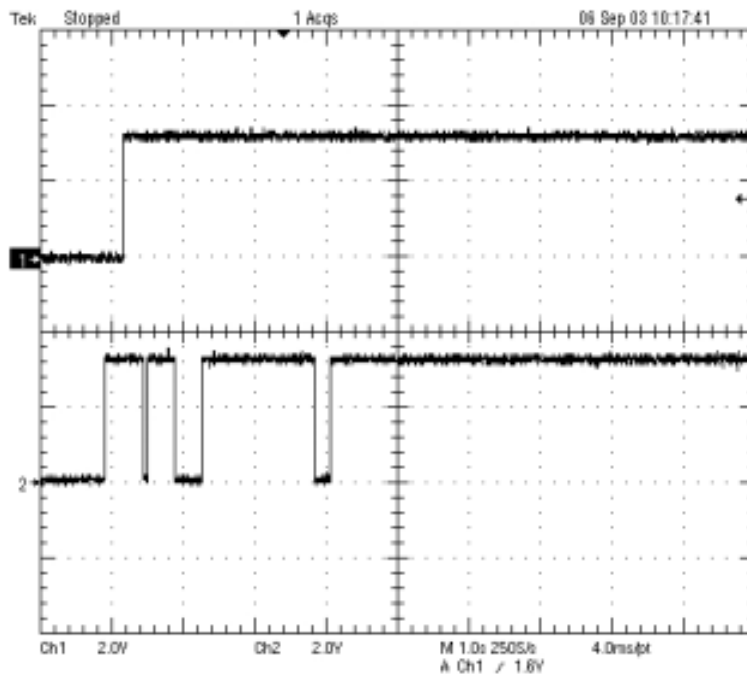

**LDENDVD
(CN102 PIN 17)**

**LDENC
(CN102 PIN 38)**

33. Laser Power(reading)_DVD+RW

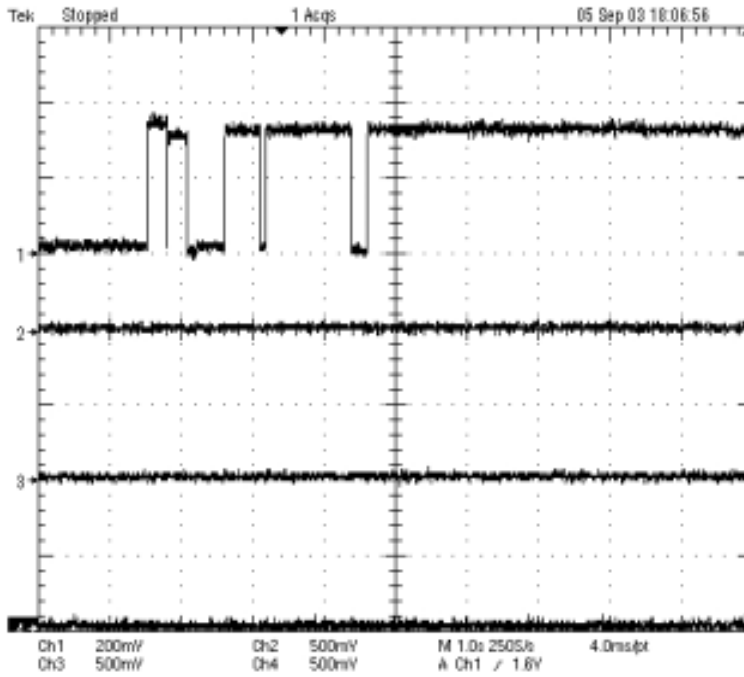

VRDC(CN102 PIN 34)

VWDC1(CN102 PIN 36)

VWDC2(CN102 PIN 35)

OPECTRG
(IC1201 PIN 165)

34. Laser Power(Erase)_DVD+RW

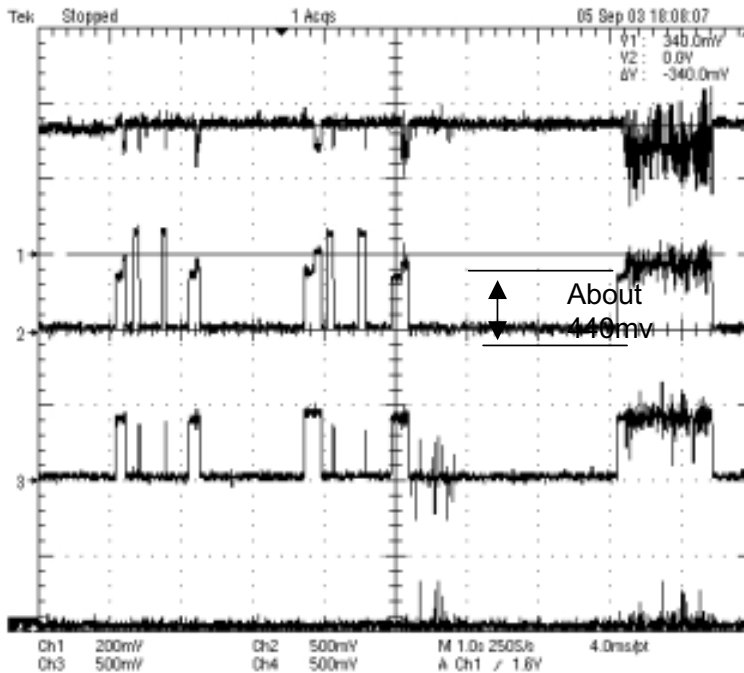

VRDC(CN102 PIN 34)

VWDC1(CN102 PIN 36)

VWDC2(CN102 PIN 35)

OPECTRG
(IC1201 PIN 165)

35. Laser Power(Writing)_initial state

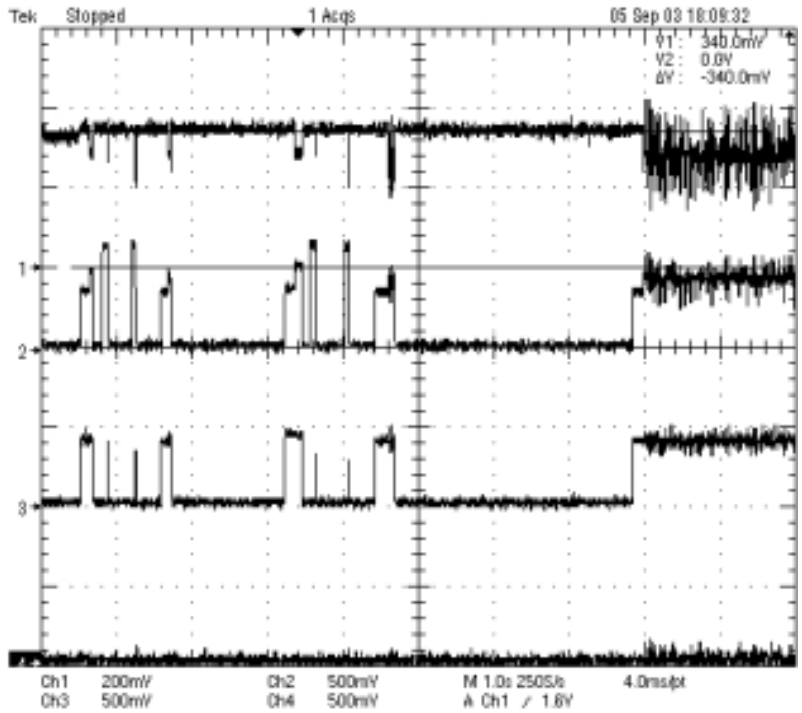

VRDC(CN102 PIN 34)

VWDC1(CN102 PIN 36)

VWDC2(CN102 PIN 35)

OPECTRG
(IC1201 PIN 165)

36. Laser Power(Writing)_Processing

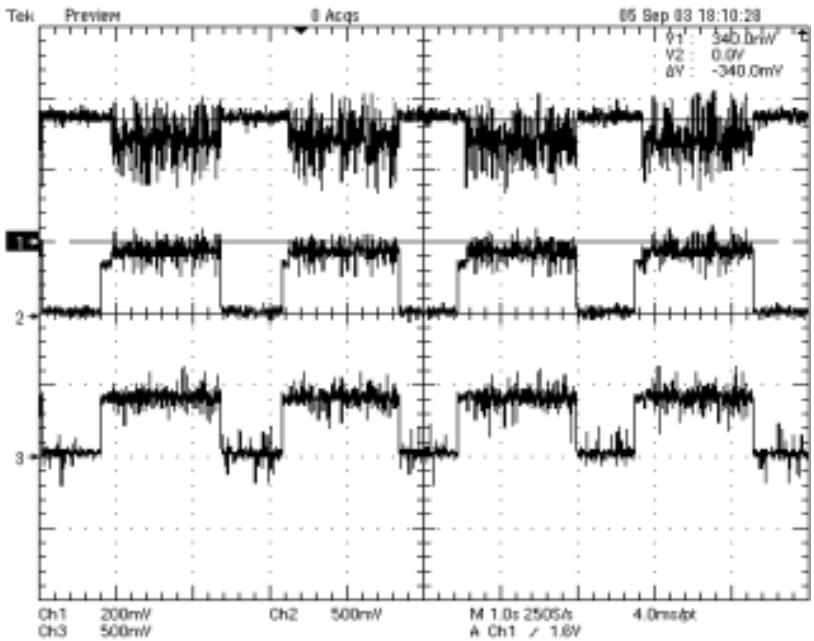

VRDC(CN102 PIN 34)

VWDC1(CN102 PIN 36)

VWDC2(CN102 PIN 35)

The difference of DVD-R/RW, DVD+R/RW discs and DVD-ROM

1. Recording Layer

- DVD-ROM (Read Only Disc)

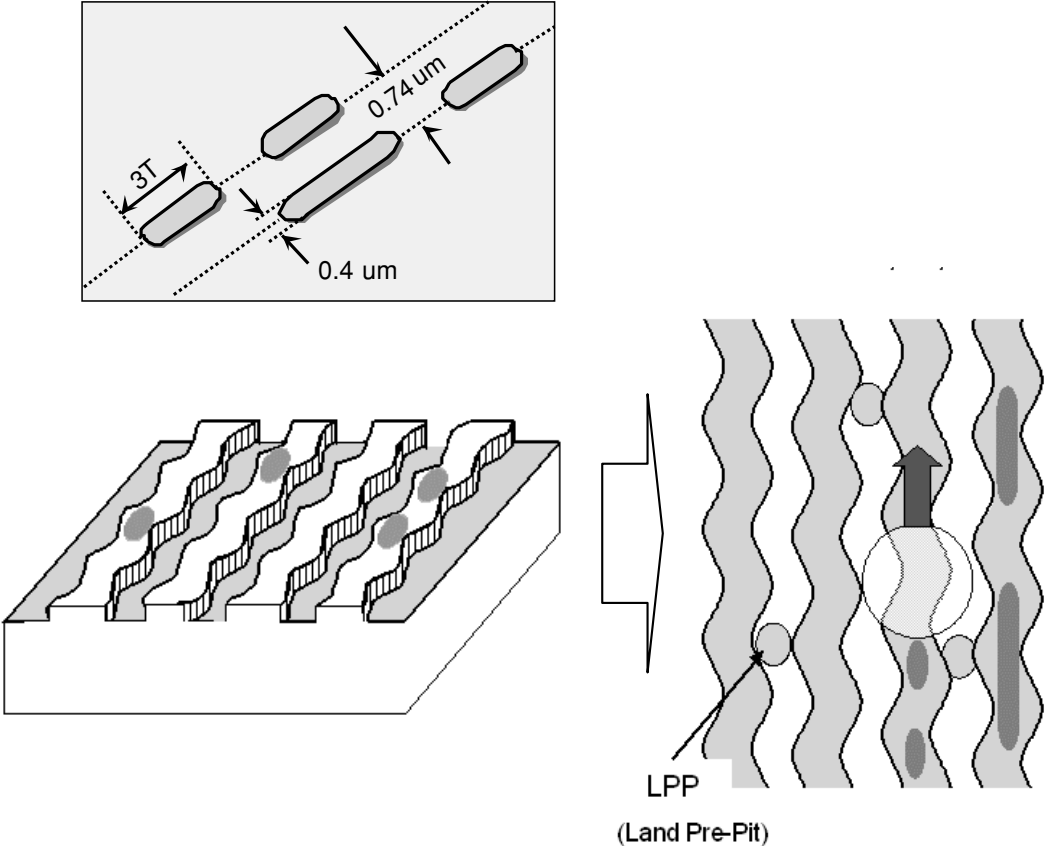

- DVD+R/RW Disc

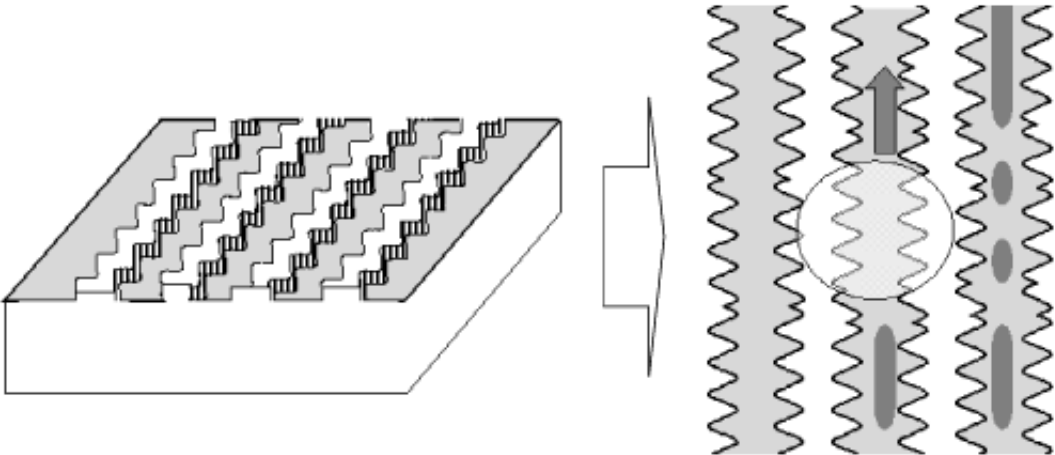

2. Disc Specification

	DVD-ROM		DVD-R	DVD-RW	DVD+R	DVD+RW
	Single-Layer	Dual-Layer				
Media Type	Read Only	Read Only	Dye	Phase change	Dye	Phase change
User data capacity	4.7GB	8.54GB	4.7GB	4.7GB	4.7GB	4.7GB
Wavelength	650nm	650nm	650nm	650nm	650nm	650nm
Reflectivity	45~85%	18~30%	45~85%	18~30%	45~85%	18~30%
Track pitch	0.74 μ m	0.74 μ m	0.74 μ m	0.74 μ m	0.74 μ m	0.74 μ m
Minimum pit length	0.4 μ m	0.4 μ m	0.4 μ m	0.4 μ m	0.4 μ m	0.4 μ m
Modulation	>0.6	>0.6	>0.6	>0.6	>0.6	>0.6
Channel bit-rate	26.16MHz	26.16MHz	26.16MHz	26.16MHz	26.16MHz	26.16MHz
Wobble Frequency	–	–	140KHz	140KHz	817.4KHz	817.4KHz
Addressing	26.16MHz	26.16MHz	Wobble & LPP	Wobble & LPP	Wobble(ADIP)	Wobble(ADIP)
Read Power (mW)					0.7 \pm 0.1	0.7 \pm 0.1
Write Power (mW)	–					
Jitter	<8%	<8%	<8%	<8%	<9%	<9%

3. Disc Materials

1) DVD-ROM

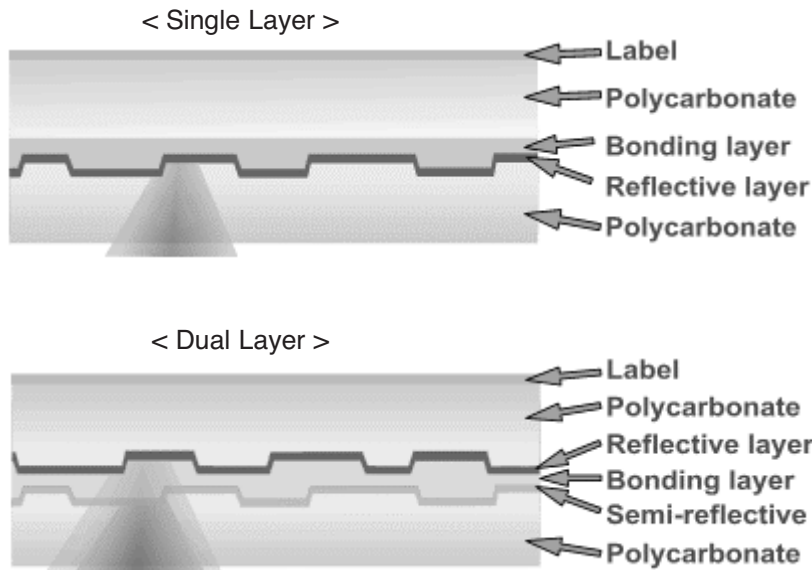

2) Recording format using organic dye material (DVD-R / DVD+R)

The format that records data through the creation of recorded marks by changing the organic dye material with a laser beam.

► Disc structure

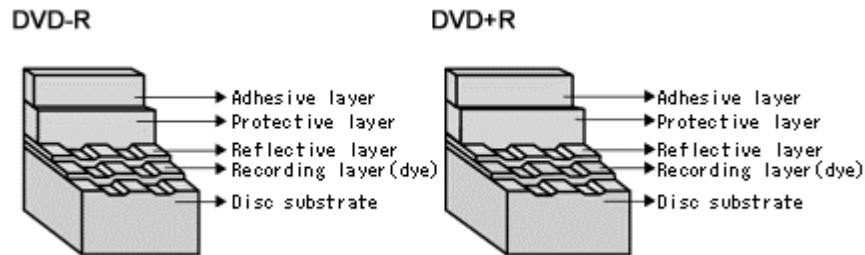

► Recording principles

[Recording]

Recording is done by changing the organic dye layer and the substrate with a laser. When a strong laser is applied to a disc, the temperature of the organic dye material goes up, the dye is decomposed and the substrate changes at the same time. At this time, a durable bit is created as is the case with a CD-ROM.

[Playback]

Signals are read with the differences of the reflection of a laser from pits.

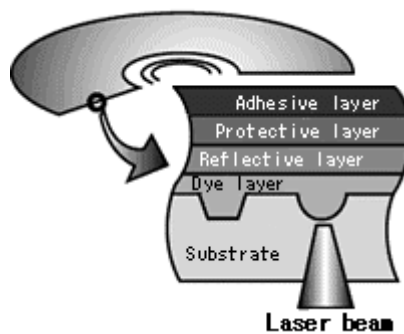

3) Recording format using phase-change recording material (DVD-RW / DVD+RW)

- Data is recorded by changing the recording layer from the amorphous status to the crystalline status, and played back by reading the difference of the reflection coefficient.

Amorphous: Non-crystalline.

► Disc structure

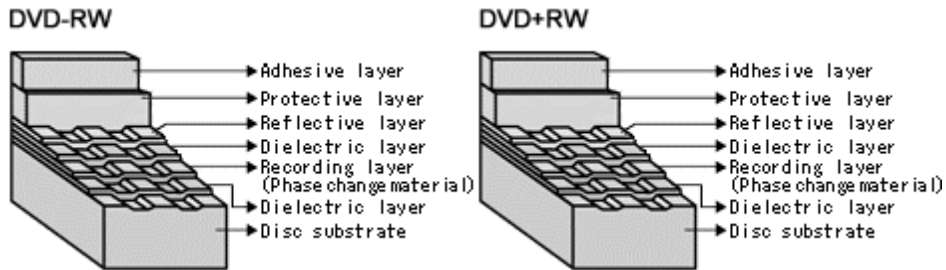

► Recording principles

[Recording]

When a high-power laser is applied to the recording material, it melts and then becomes amorphous with a low reflection coefficient when it quickly cools off. When a mid-power laser is applied to heat gradually the recording material and then gradually cools it off, it becomes crystal with a high reflection coefficient.

[Playback]

A low-power laser is used for playback. The amount of reflected light depends on the status (amorphous or crystalline) of the recording material. This is detected by an optical sensor.

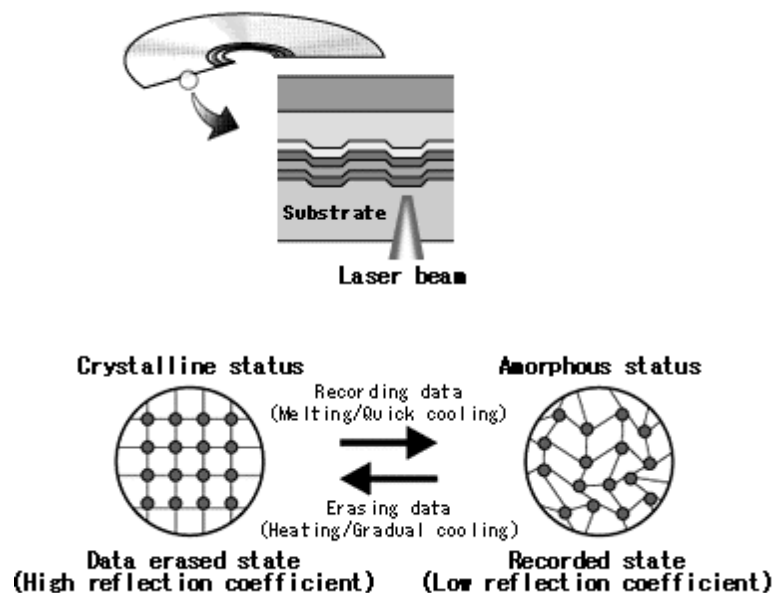

To make recordings, it is necessary to modulate the write pulse, which is called "Write Strategy". There can be many types in Write Strategy. Typically Write Strategy for DVD \pm R has NMP(Non Multi-Pulse) type and MP(Multi-Pulse) type. In NMP type each single mark is created by subsequent separated short pulses. In MP type each single mark is created by one continuous pulse. Write Strategy for DVD \pm RW has Type 1 and Type2. In Type 1 the mark with nT width is created by one top pulse and $(n-2)$ multi-pulses. Thus mark $3T$ is made by one top pulse and one multi-pulse. In Type 2 the mark with nT width is created by one top pulse and $(n-3)$ multi-pulses. Thus mark $3T$ is made by one top pulse only. RL-02A uses MP type Write Strategy for DVD \pm R and Type 1 for DVD \pm RW as shown below.

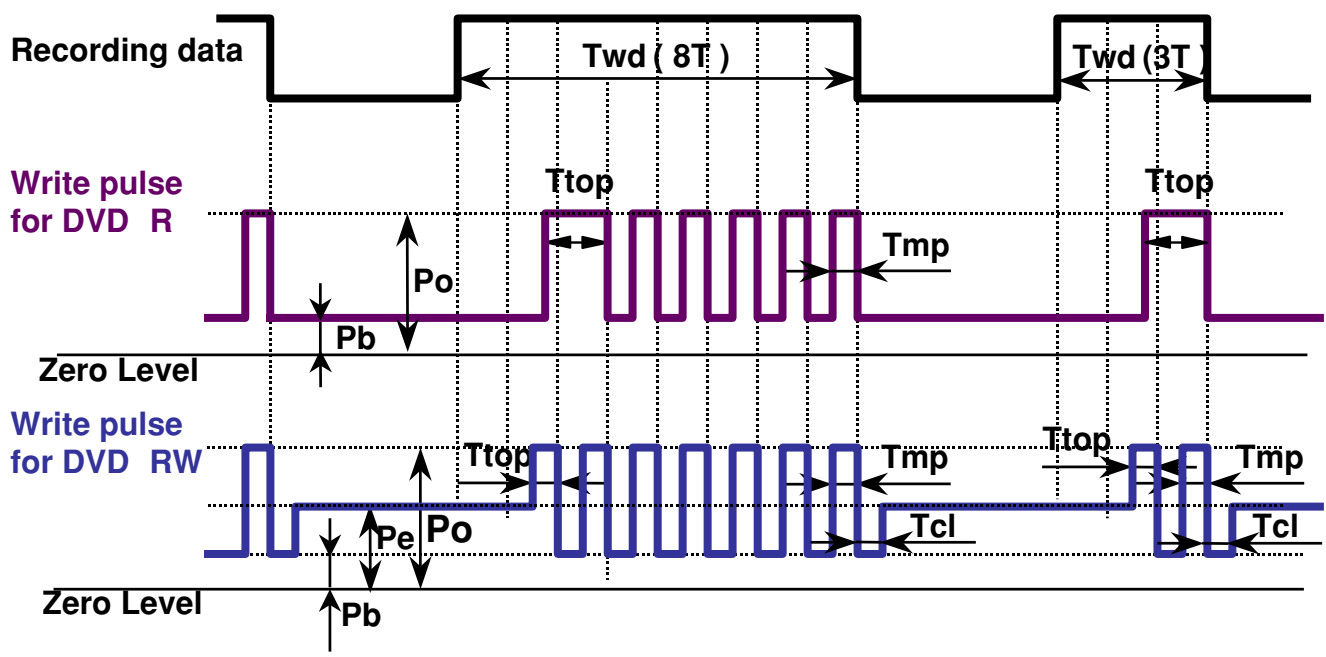

P_o :Write Power (Peak Power)
 P_e :Erase Power
 P_b :Bias Power

4. Organization of the Inner Drive Area, Outer Drive Area, Lead-in Zone and Lead-out Zone

1) Layout of DVD-ROM disc

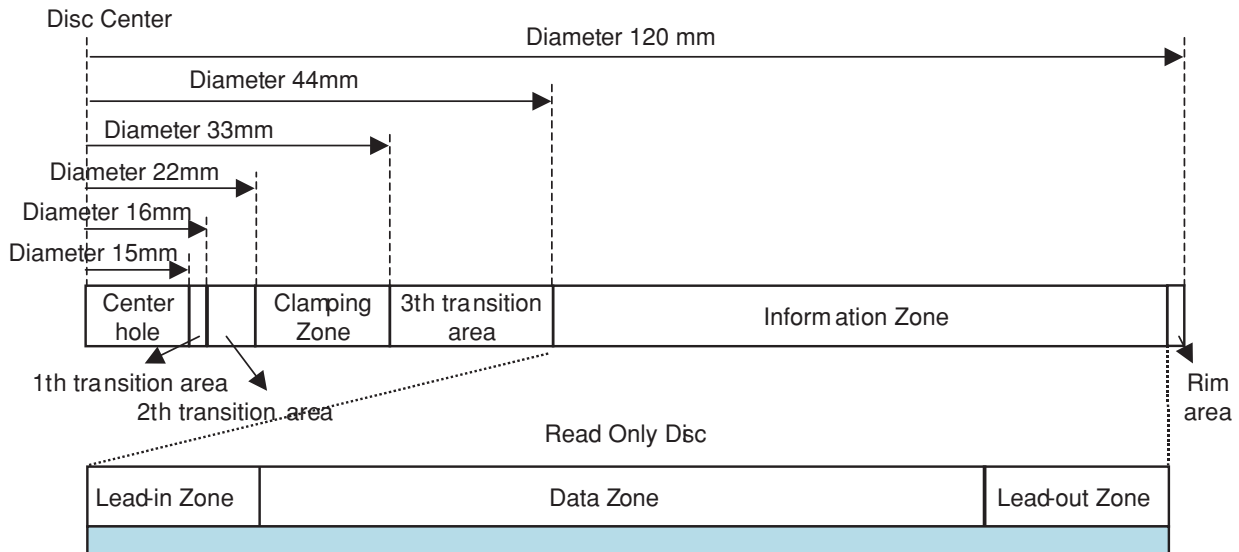

2) Layout of DVD+R disc

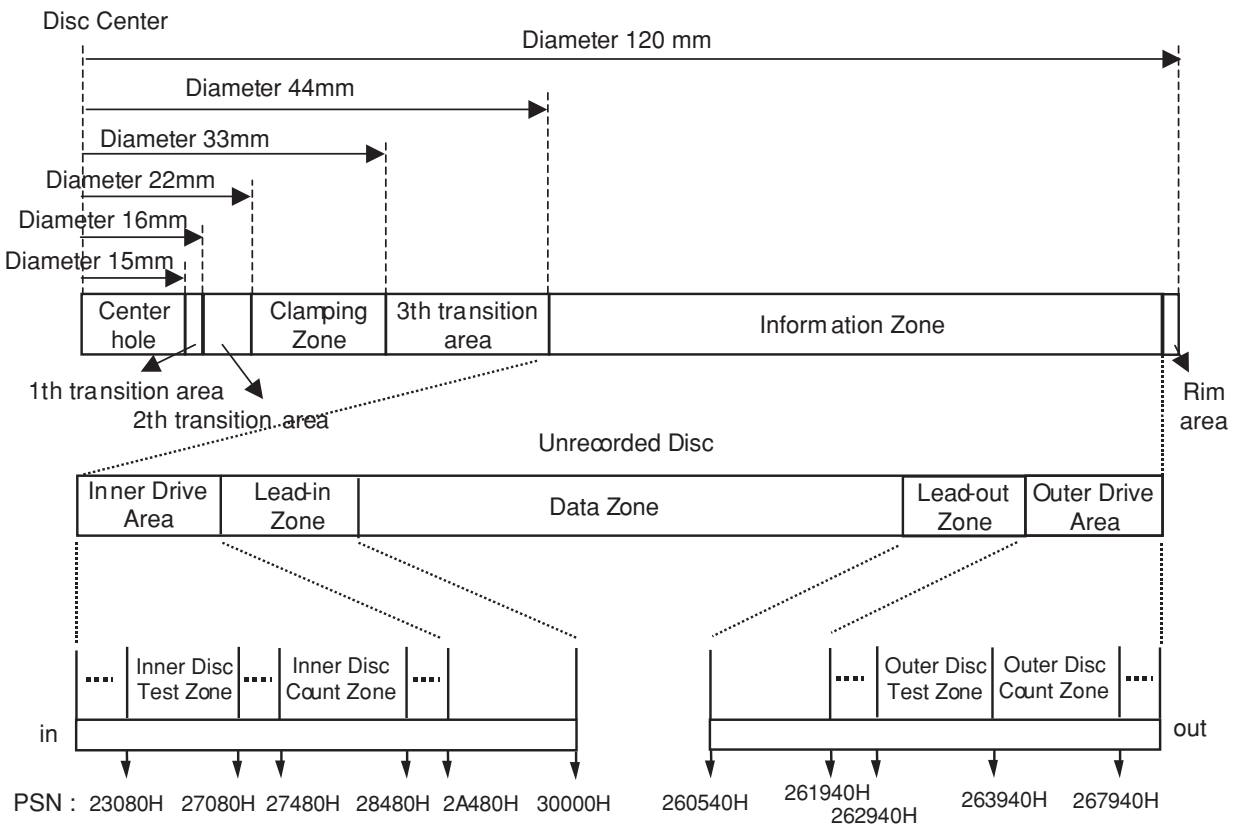

Inner Disc Test Zone : for performing OPC procedures.

Inner Disc Count Zone : For counting the number of OPC algorithm performed in IDT Zone.

Outer Disc Test Zone : for performing OPC procedures.

Outer Disc Count Zone : For counting the number of OPC algorithm performed in IDT Zone.

3) Layout of DVD+RW disc

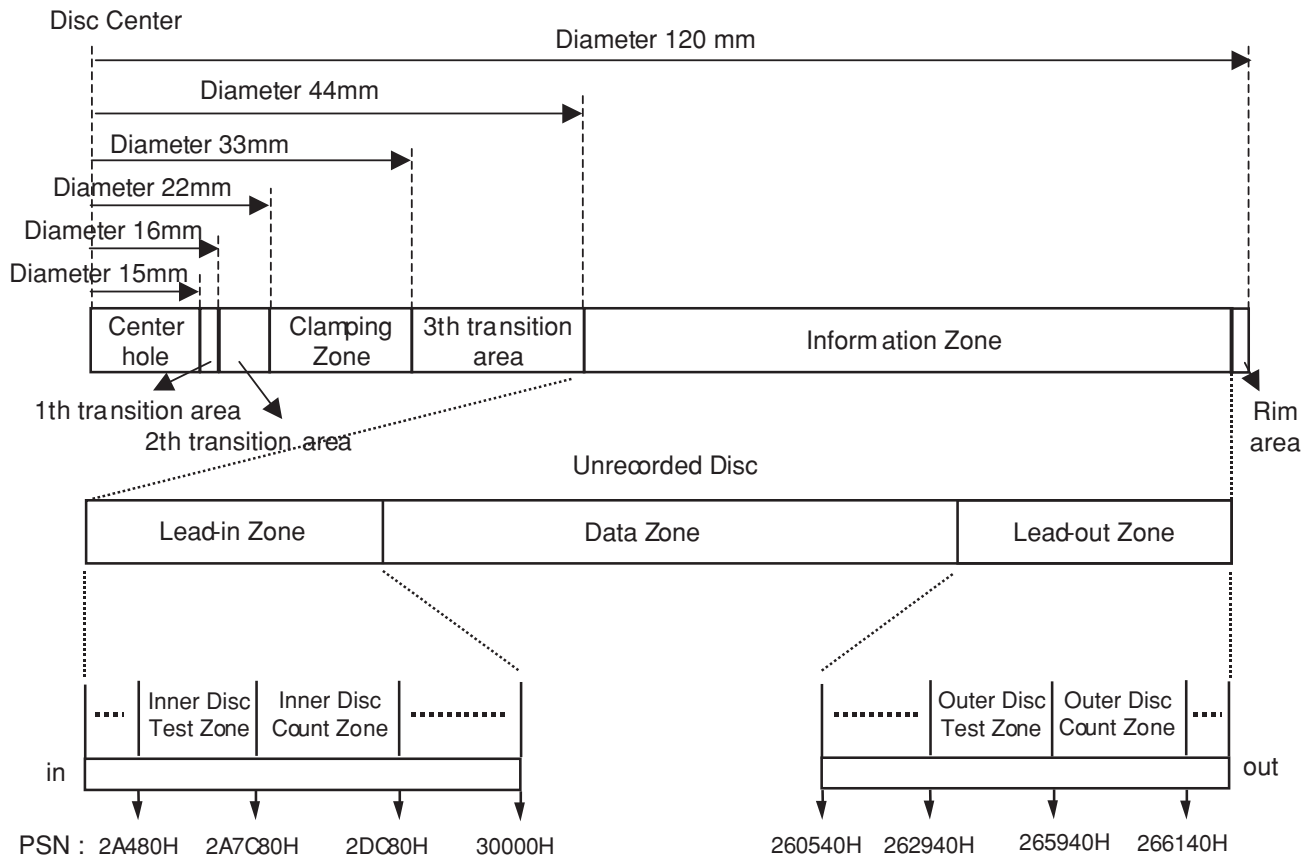

Inner Disc Test Zone : for performing OPC procedures.

Inner Disc Count Zone : For counting the number of OPC algorithm performed in IDT Zone.

Outer Disc Test Zone : for performing OPC procedures.

Outer Disc Count Zone : For counting the number of OPC algorithm performed in IDT Zone.

4) Layout of DVD-R/RW disc

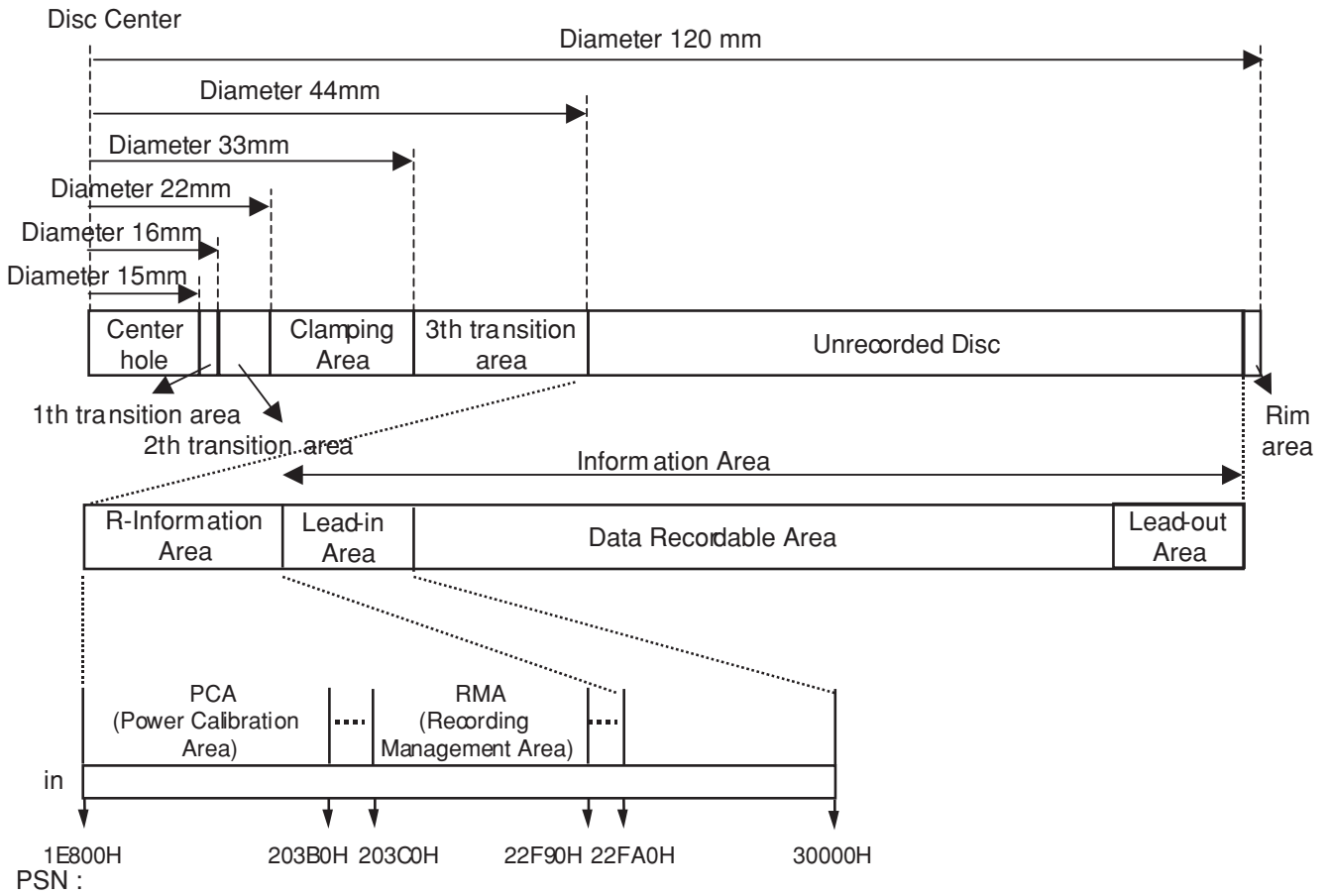

5. ALPC(Automatic Laser Power Control) Circuit

1) Block Diagram

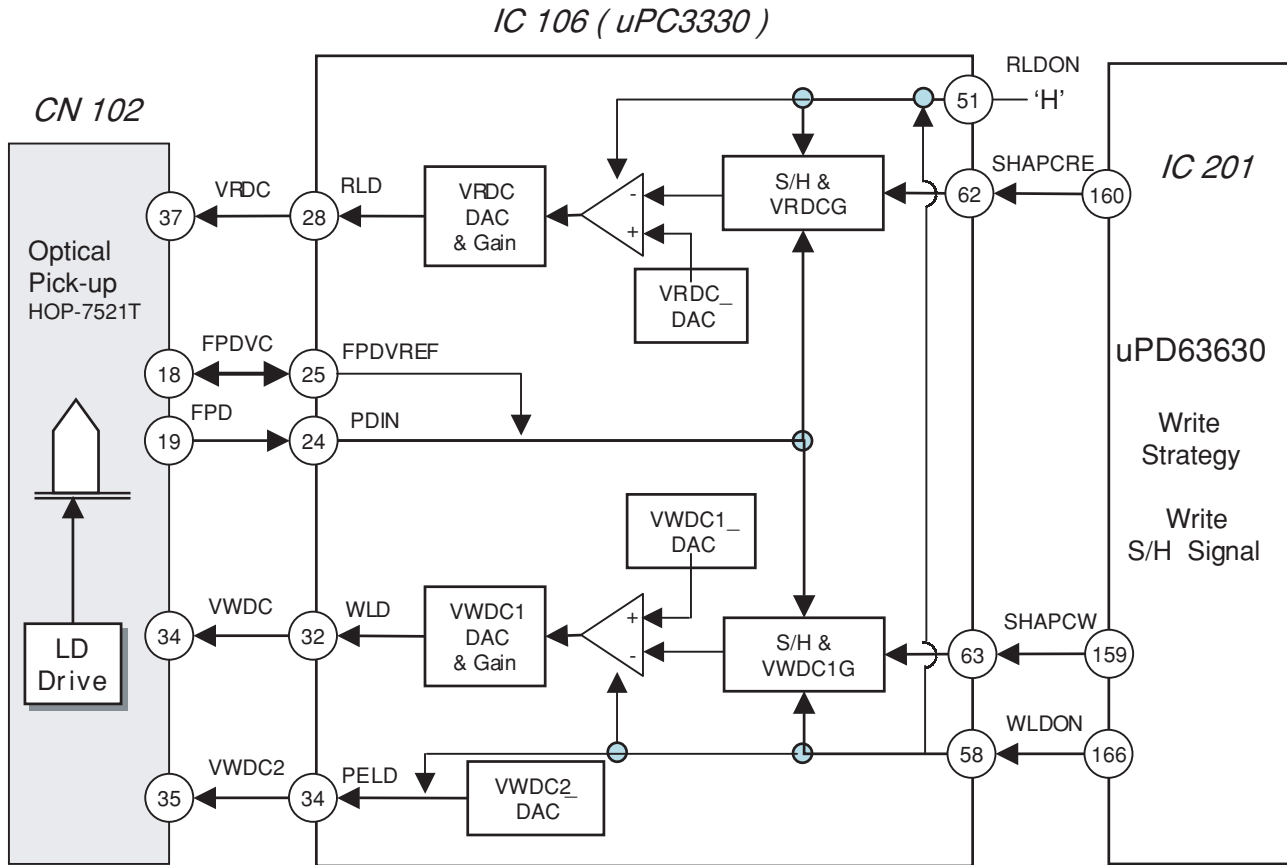

2) ALPC(Automatic Laser Power Control) Circuit Operation

ALPC function in CD-R/RW,DVD+R/RW analog front-end is for constant power level control purpose.

Based on the accurate power sensor(FPD) in OPU, ALPC feedback loop maintains constant power level against laser diode's temperature variation.

There are two power control loops in uPC3330, which are used with different combination for different applications. Generally, the first ALPC loop is used for read-power control. The 2nd ALPC loop is used for write(erase) power control for CD-R/RW and DVD+R/RW disc.

Owing to the small signal level in read-power control mode, the first ALPC loop amplifies the FPD signal to enhance the accuracy of read power control. The built-in 10-bit DAC(VRDC_DAC) is used to set the read power level.

Moreover, the 2nd ALPC loop is used for high power control. The built-in 10-bit DAC(VWDC1_DAC) is used to set the wanted power level.

And the register VWDC1G is employed to adjust the gain of FPD signal.

The following potentiometers(VRDC_DAC, VWDC1_DAC, and VWDC2_DAC) and amplifiers (VRDCG and VWDC1G) are used to set the wanted levels of the output pins RLD, WLD, and PELD

How to use test tool

1. ALPC Measurement System Configuration

In order to measure and adjust DVD RW optical power, The following measurement equipments are needed.

- ◆ Compulsory equipment
 - ① Optical Power meter & Sensor (ADVANTEST, TQ8210/Q82017A or equivalent)
 - ② Personal Computer (Pentium 3, 500MHz Above, , RAM:64M Above, Win98 Above)
 - ③ Adjustment Program (Dragon or ALPC) for SVC, ALPC Program recommended
- ◆ FI optional equipment
 - ① USB-ATAPI Interface (needed when using USB Port from the laptop computer without ATAPI interface or a desktop computer)
 - ② Connector-ATAPI Interface Board(Part Mo:6881R-7677A) (needed when ATAPI is not attached to Loader)

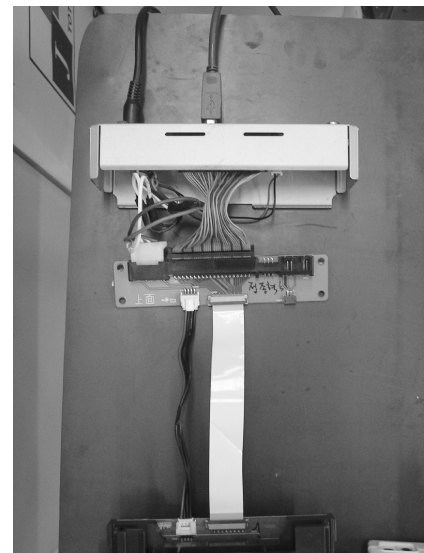
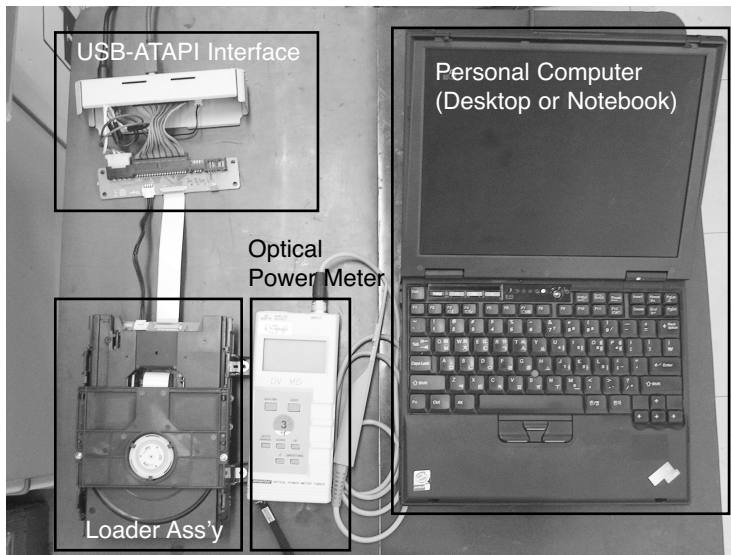

2. ALPC Program Configuration

ALPC Program consists of total 4 files.

- ALPC.exe
- LgBada.dll
- modelnm.txt
- WNASPI32.DLL

These 4 files should be located in one directory.
ALPC.exe is a program execution file.
modelnm.txt is a configuration file.

Determine how to connect

The following contents are included when you open "modelnm.txt" file.

The following contents are included when you open LGE connect=0

connect=0 is the item which you can determine whether you use Serial or ATAPI.

- 0 : ATAPI
- 1 : Serial

Thus, select connect=0 to use ATAPI, or select connect=1 to use Serial, then save the file.
(For SVC, ATAPI setting is recommended.)

3. Running ALPC Program

When running ALPC.exe file, the following screen appears.

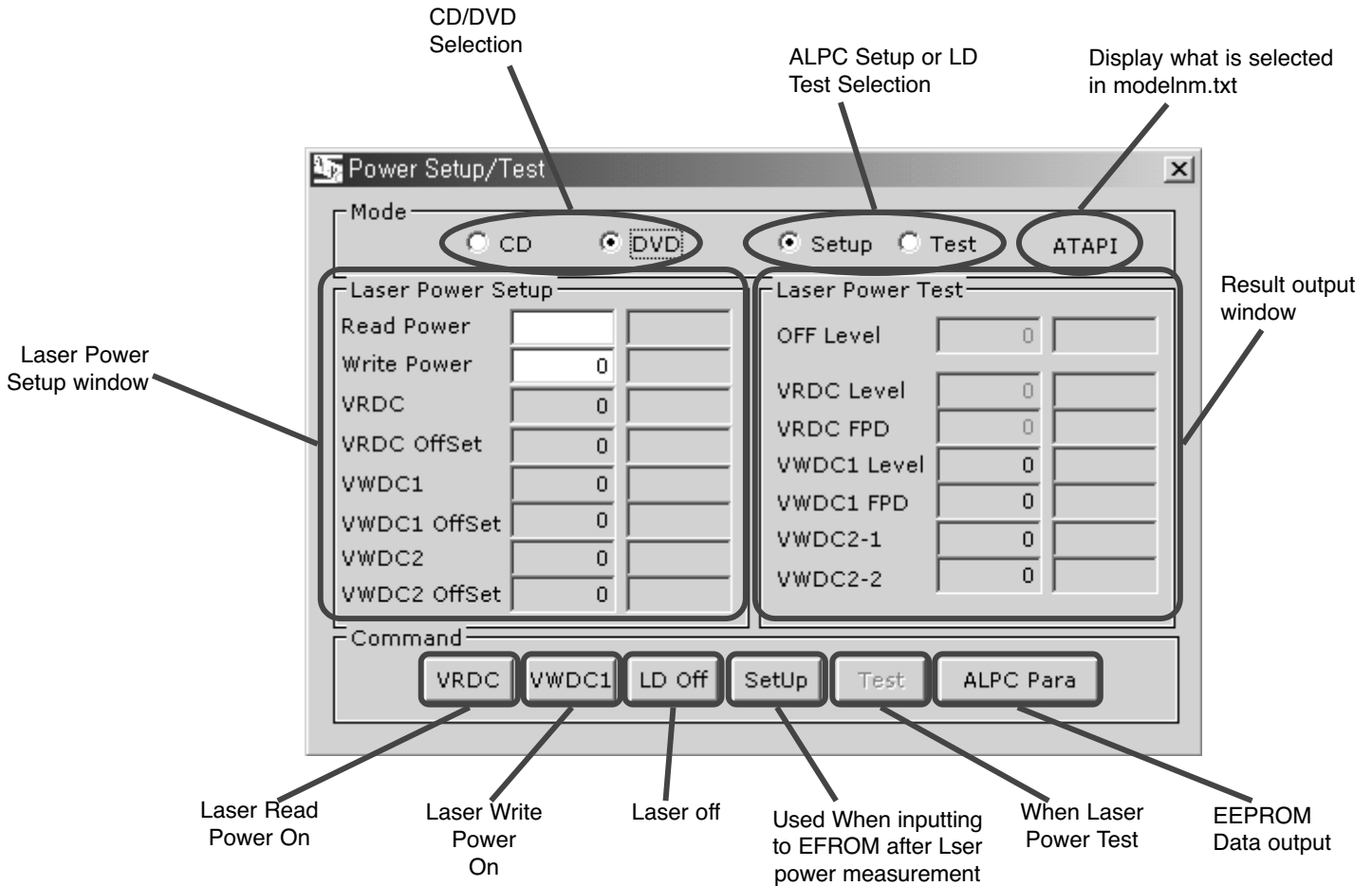

4 LD Test

* Test DVD LD

- ① Select DVD mode
- ② Select Test mode
- ③ Click

* Test DVD CD

- ① Select CD mode
- ② Select Test mode
- ③ Click

Section	Off	VRDC	VR_FPD	VWDC1	VW_FPD	VW2-1	VW2-2
CD	2.4±0.08	0.53±0.22	0.02±0.01	0.36±0.06	0.115±0.015	0.034±0.01	0.125±0.020
DVD	2.4±0.08	0.7±0.2	0.04±0.01	0.43±0.05	0.2±0.02	0.08±0.02	0.2±0.03

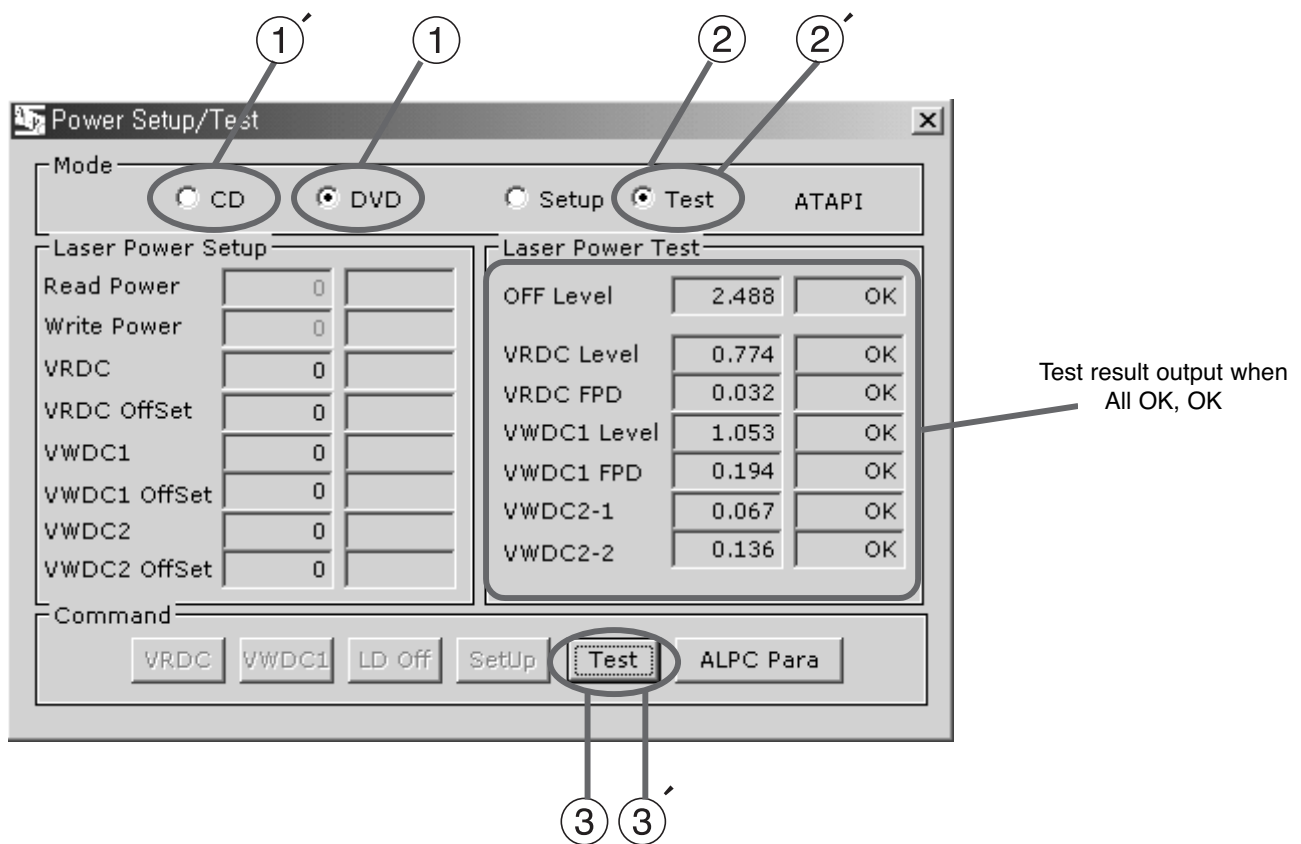

Specification can be changed according to pick-up type, circuit, program, and chipset.
 If specification is changed, program can be sent by supervisor.
 Specification above is temporary reference.

5. Optical Power Setting

When replacing Travers ass'y including Pick-up or Loader PCB, Optical Power Setting should be performed for Pick-up and Loading PCB's matching.

① DVD LD optical Power Setting

- Select DVD and Setup mode
- Push **VRDC**. (Read Power On. Strong Red light can be seen from pick up optical lens.)
- Measure optical power.
- Write measurement value in Read Power.
- Push **VWDC1**. (Write power On.) (Caution) Light is very strong. Never look at the light directly.
- Measure optical power
- Write measurement value in Read Power and push LD off **LD Off**.
- Push **Setup**. (Measurement value is inputted to EEPROM)

② DVD LD optical Power Setting

- Select CD and Setup mode
- Push **VRDC**. (Read Power On. Weak Red light can be seen from pick up optical lens.)
- Measure optical power.
- Write measurement value in Read Power.
- Push **VWDC1**. (Write power On. Weak Red light can be seen.)
- Measure optical power and push LD off **LD Off**.
- Write measurement value in Read Power.
- Push **Setup**. (Measurement value is inputted to EEPROM)

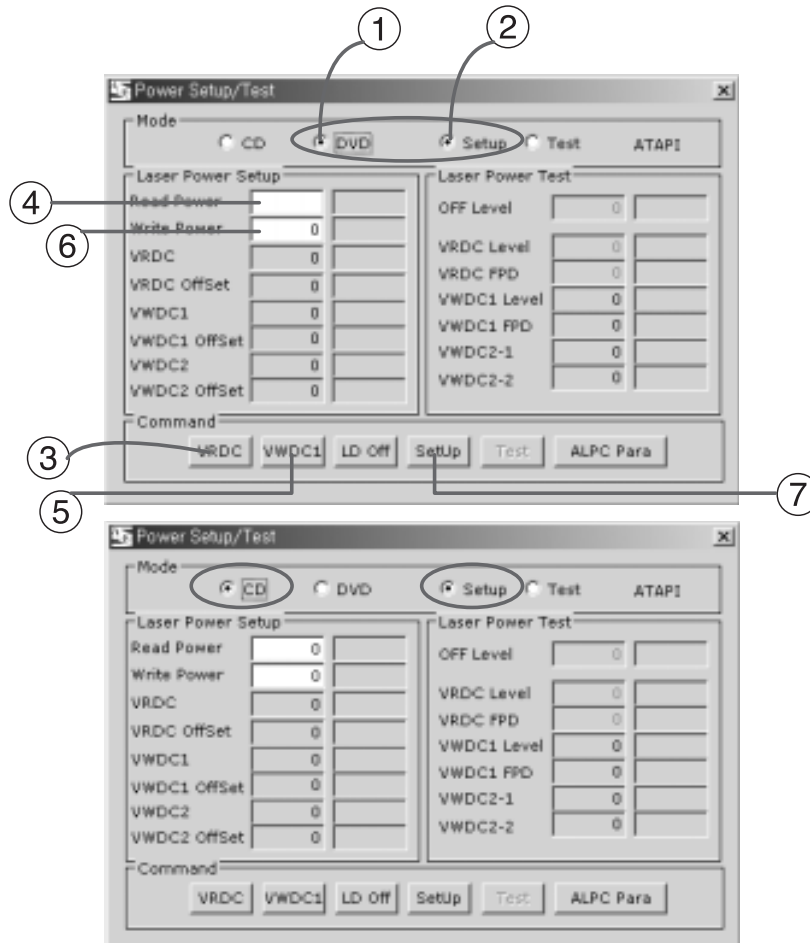

6. Optical Power Setting Parameter Check

Use when defective happens even though LD test result is normal.

When defective can be found but power test result is OK, You need to check current settings whether they are proper or not. In this case, Pressing **ALPC Para** will display ALPC Parameter Info window and show current optical power settings recorded in EEPROM(IC302).

Write down these settings on the paper, perform optical power setting and press **ALPC Para** again, then new optical power settings will appear. Compare these two parameters. If there is a big difference, optical power setting may have been wrong at first or pick-up optical output may have been changed. If pick-up is normal, problem can be solved by resetting optical power without replacing pick-up.

In order to remove previous ALPC Parameter from ALPC Parameter Info, press **Reset** at the bottom of ALPC Parameter Info window.

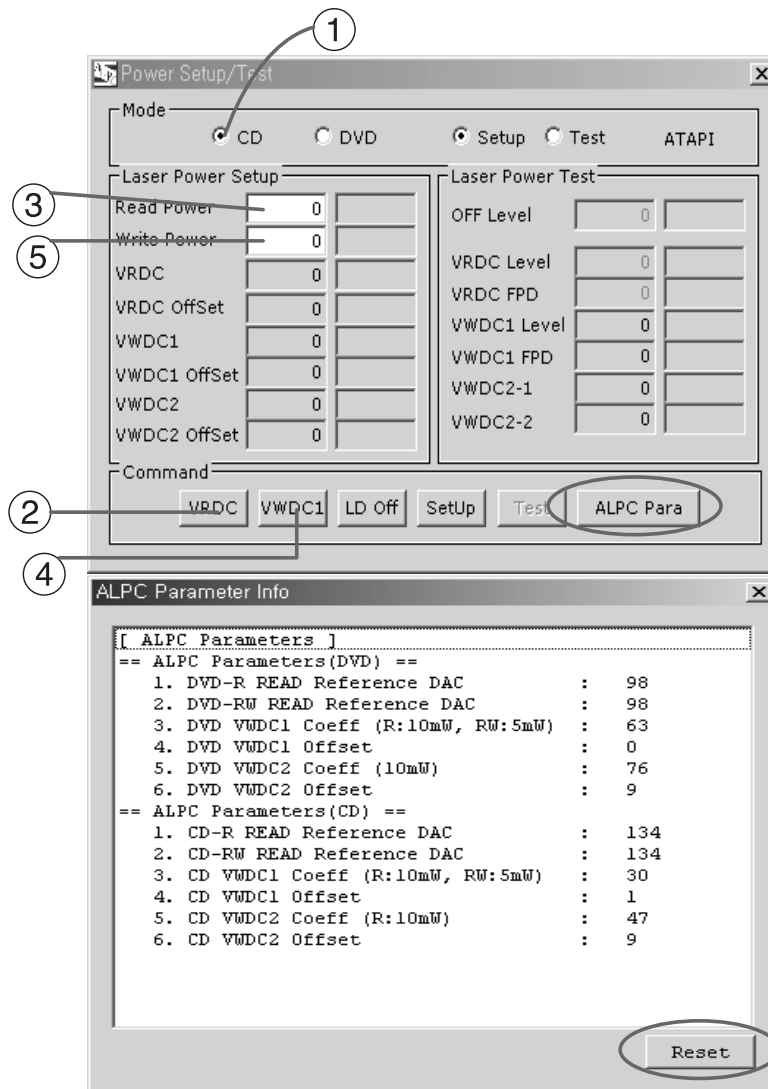

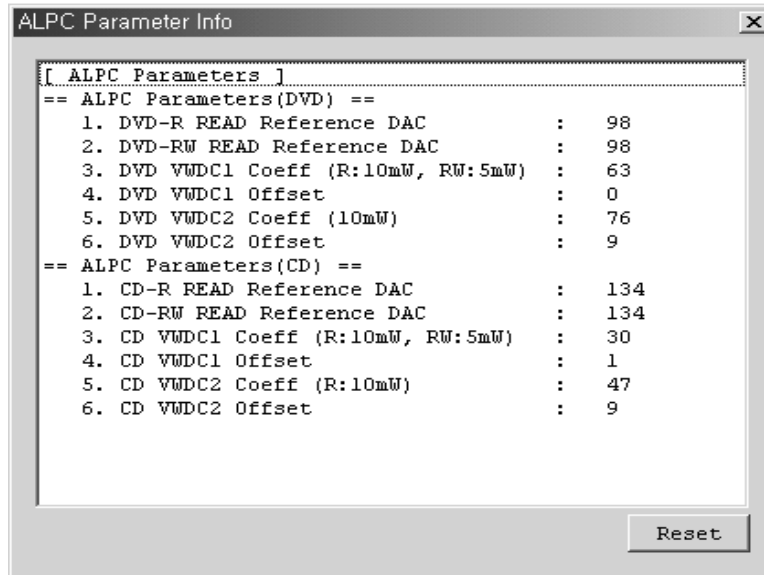

[VALID ALPC Parameters]

<CD>		<DVD>	
1) CD-R READ Reference DAC	: 64 ~ 139	1) DVD-R READ Reference DAC	: 62 ~ 93
2) CD-RW READ Reference DAC	: 64 ~ 139	2) DVD-RW READ Reference DAC	: 62 ~ 93
3) VWDC1	: 20 ~ 40	3) VWDC1	: 48 ~ 70
4) VWDC1 Offset	: 0 ~ 20	4) VWDC1 Offset	: 0 ~ 20
5) VWDC2	: 36 ~ 54	5) VWDC2	: 51 ~ 72
6) VWDC2 Offset	: 0 ~ 20	6) VWDC2 Offset	: 0 ~ 20

Appendix. How to measure optical power

Optical power measurement is measuring actual optical power coming out from an object lens with LD turned on. thus, In order to measure optical power, LD should be turned on and environment need to be dark enough.

If necessary, Cover the top side of the sensor with black paper or hand when measuring.

Generally, fluorescent light is about $50 \mu\text{W}$, sun light is about 100 mW . so, If this is ignored, optical power setting may not be set correctly.

Optical power measurement procedure

1. Adjust optical power meter's λ (wave length) to DVD. (Generally 660 nm)
2. Turn DVD LD on.
3. Place sensor less than 3mm apart from pick-up object lens, perpendicular to lens.
Adjust position so that the center of object lens match to \square mark on the sensor.
4. Read monitor's value. (Read Maximum value as moving position slightly)
(Check working unit. Unit should be mW . When LD is dead, μW or nW unit may not be read correctly.)
5. Multiply monitor's value by 100, round off to the nearest integer, then write constant part.
6. Adjust optical power meter's λ (wave length) to CD. (Generally 780 nm)
7. Turn CD LD on.
8. Repeat step 3~5 above.



2. RF Block Diagram

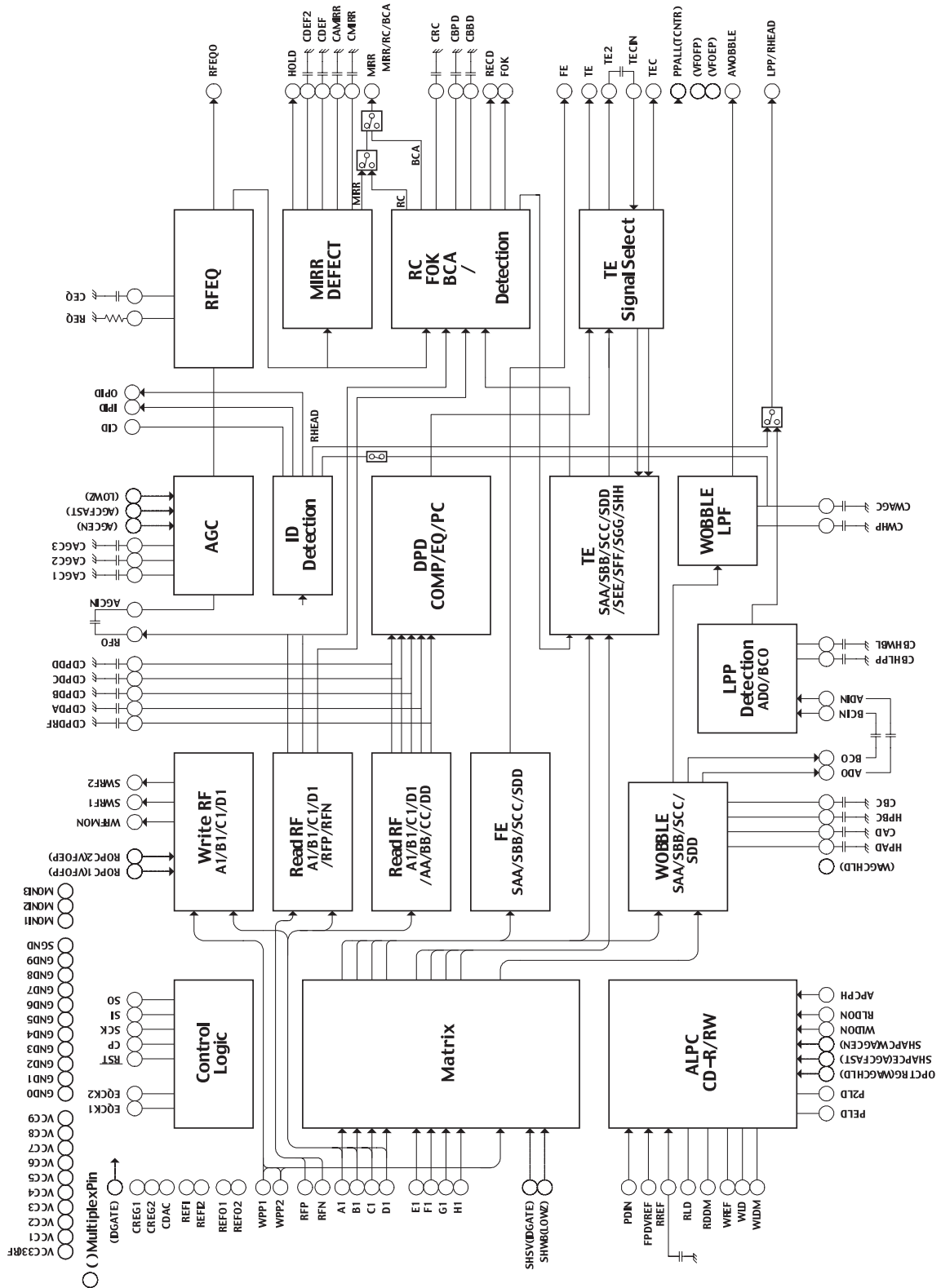

3. DSP Block Diagram

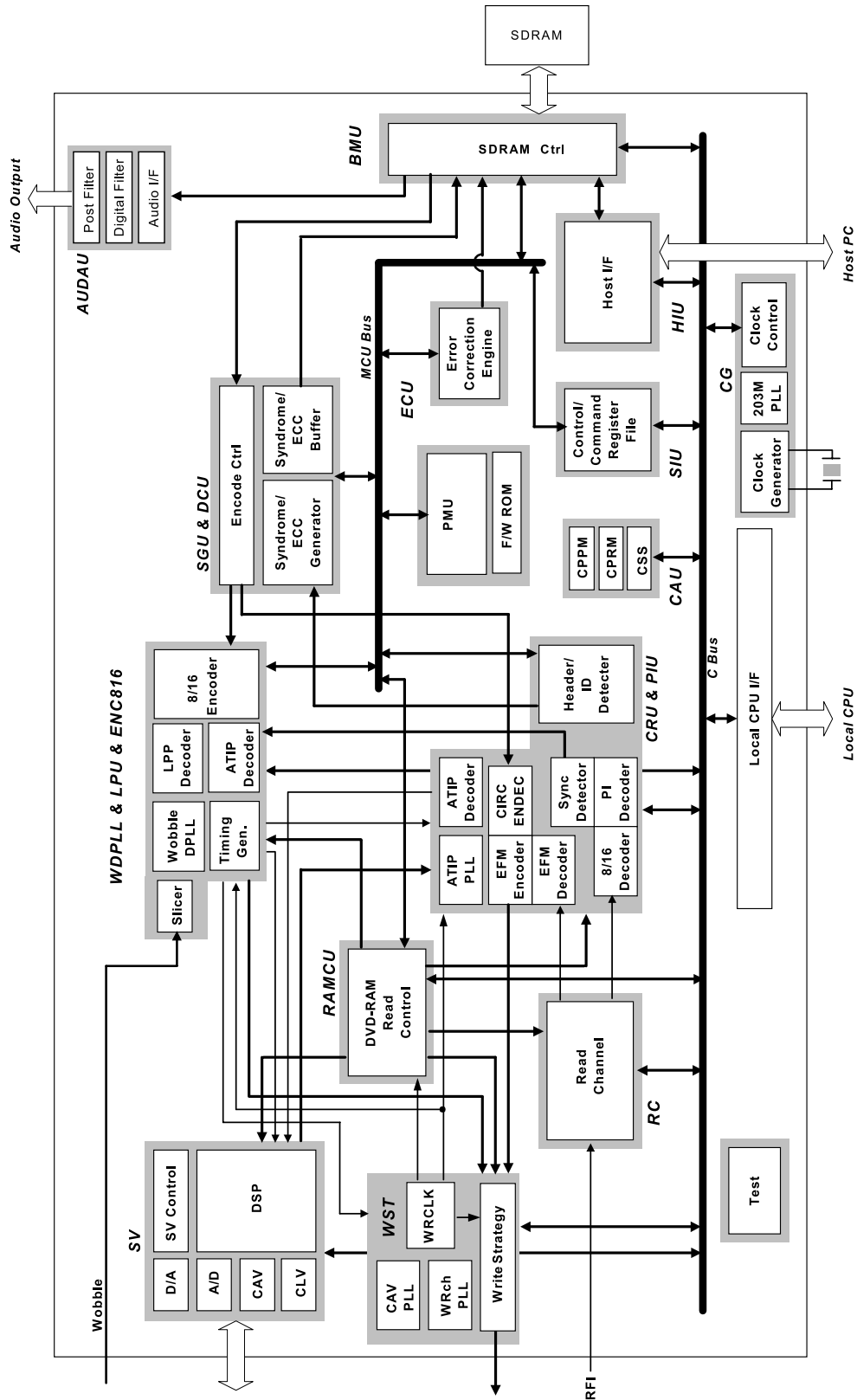

4. MICOM Block Diagram

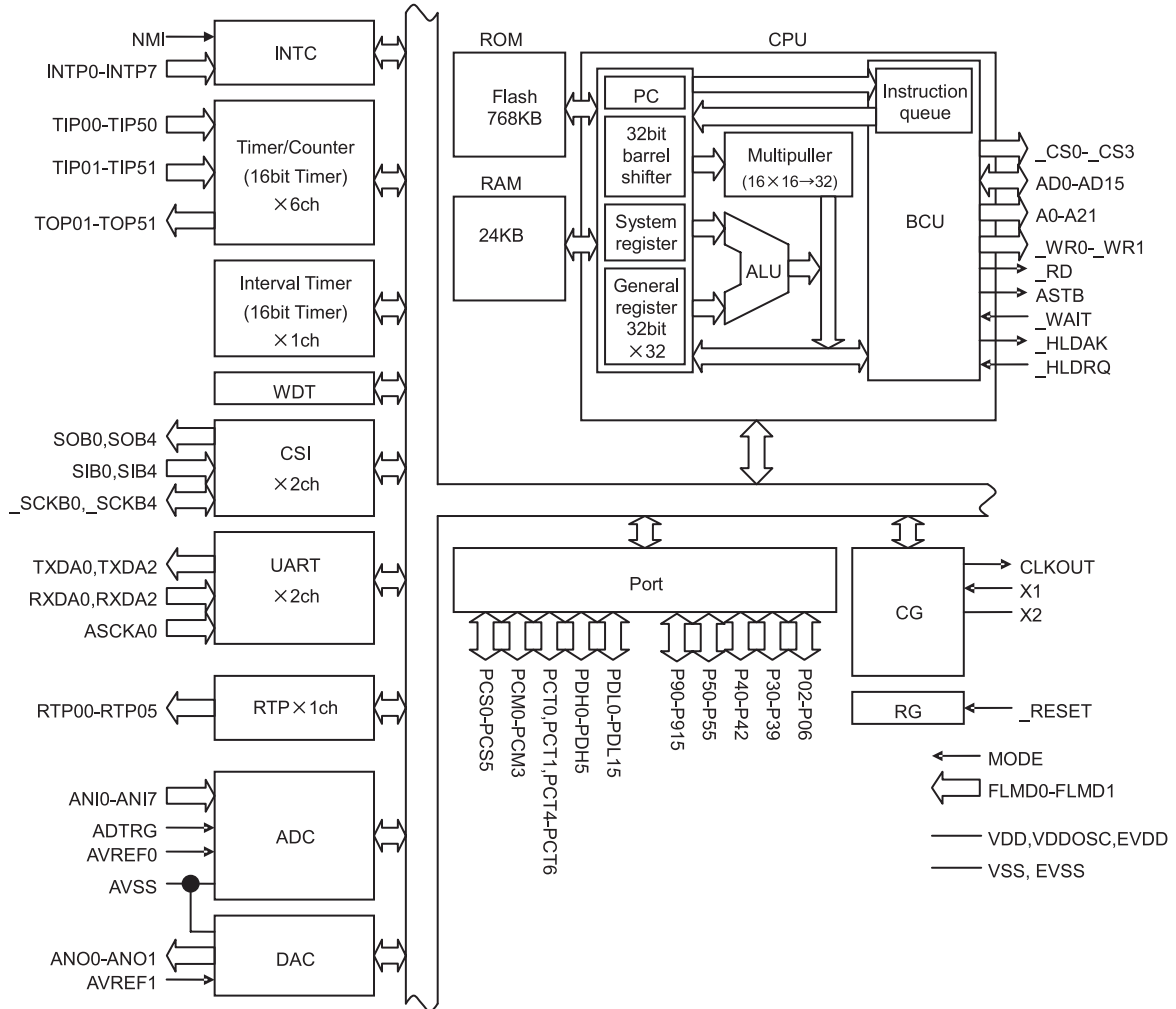

CIRCUIT DIAGRAMS

1. RF1 CIRCUIT DIAGRAM

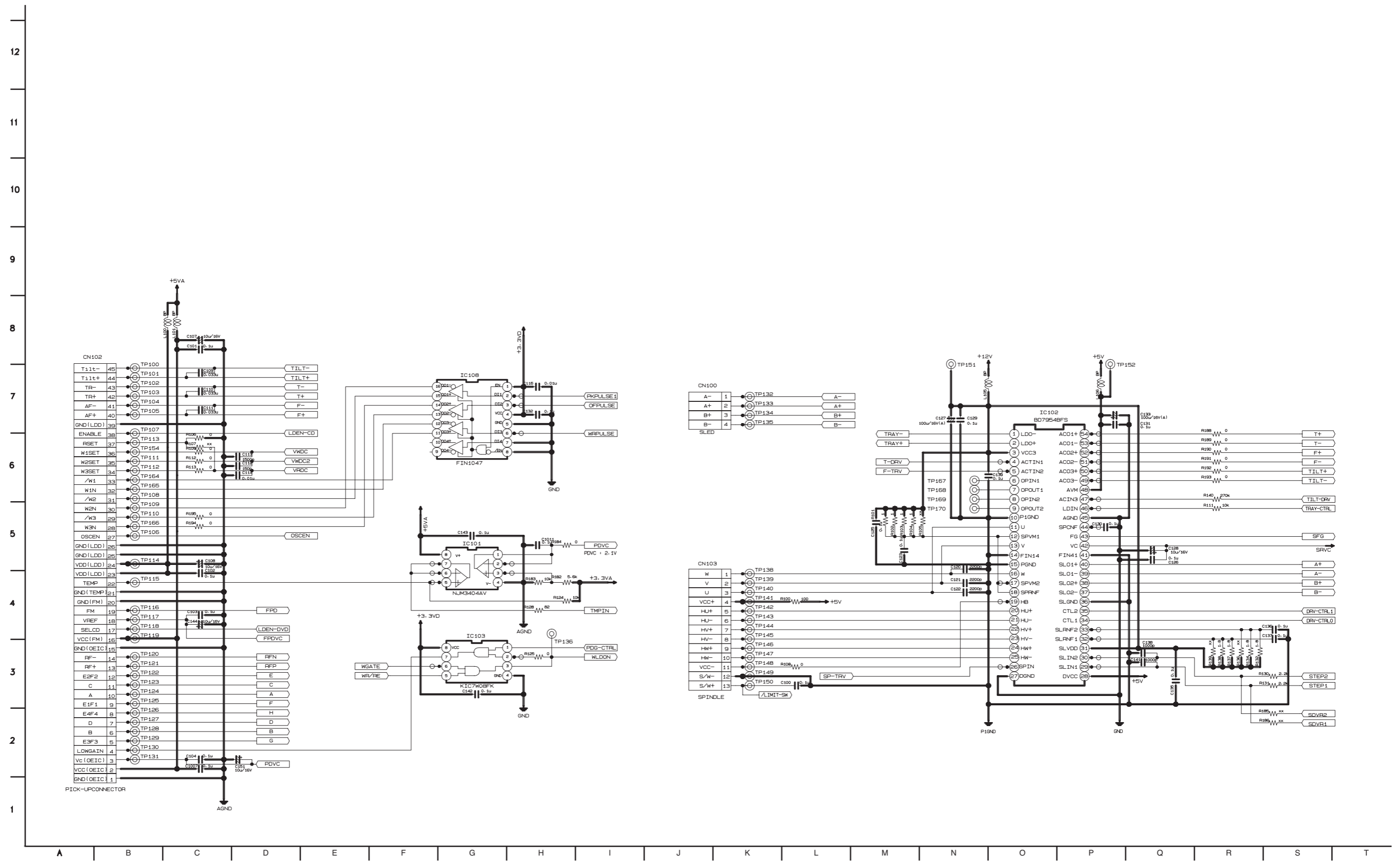

2. RF2 CIRCUIT DIAGRAM

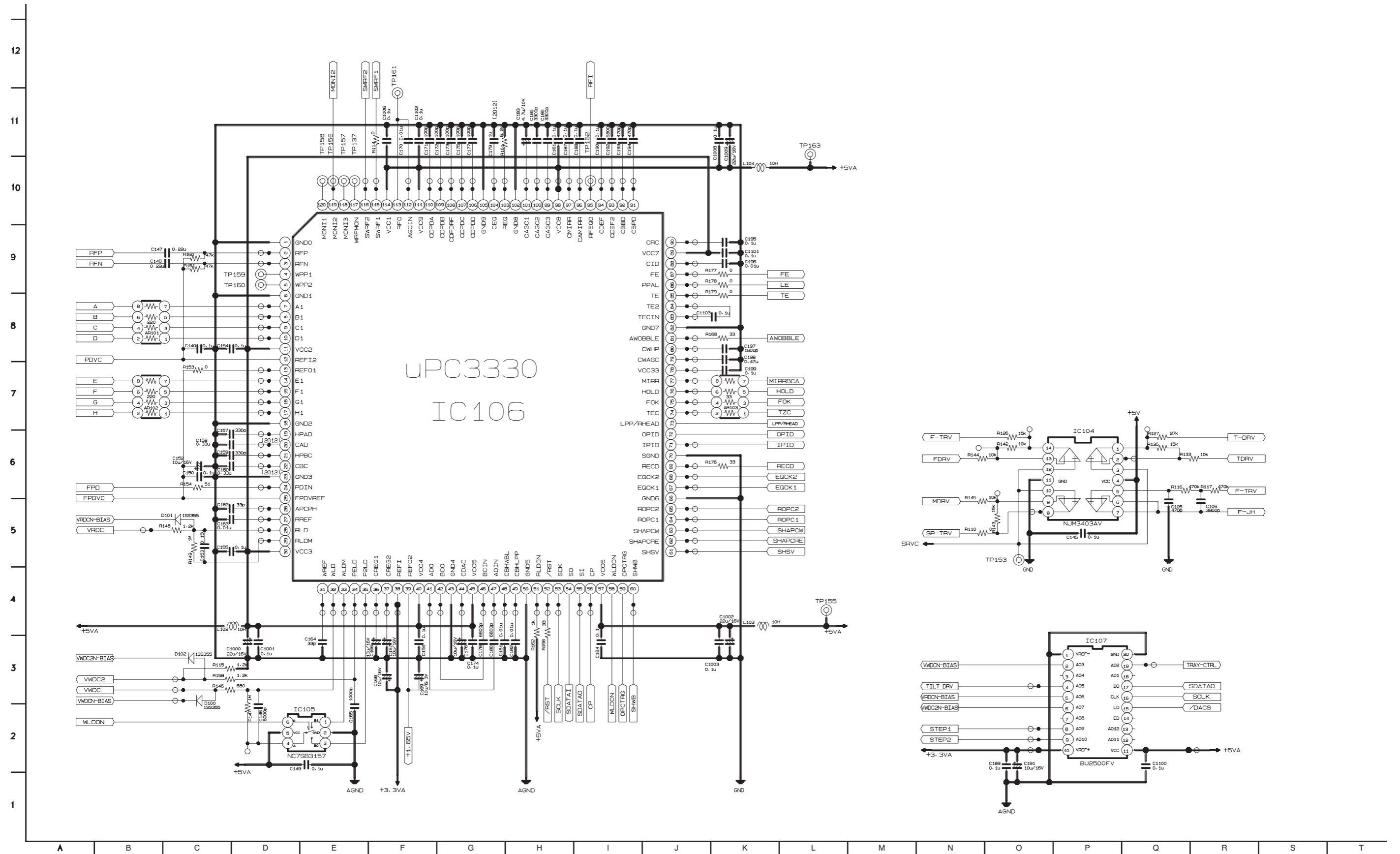

2. DSP CIRCUIT DIAGRAM

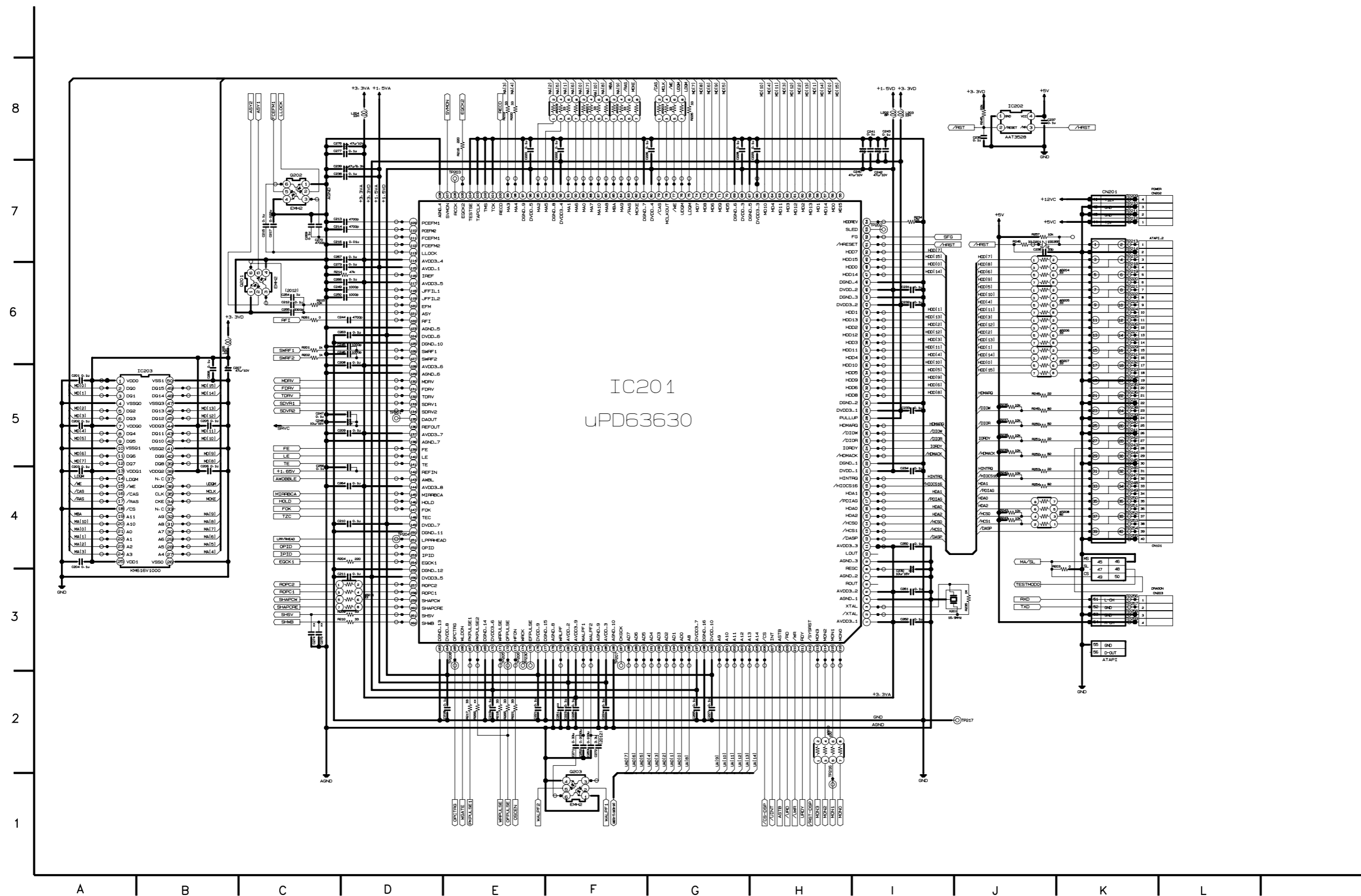

3. MICOM CIRCUIT DIAGRAM

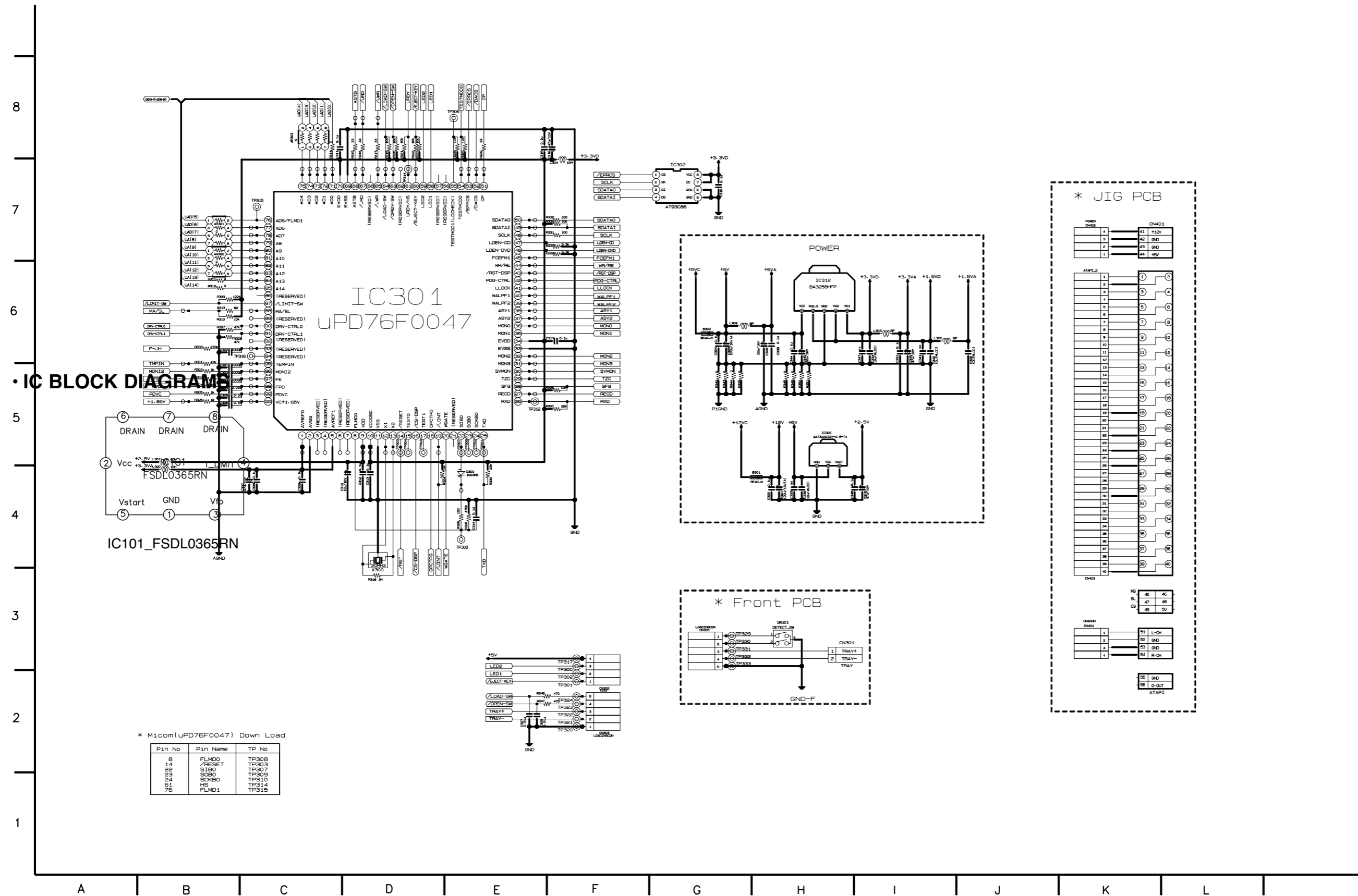

CIRCUIT VOLTAGE CHART

MODE PIN NO.	STATE
IC 101	
1	2.1
2	2.1
3	2.1
4	0
5	1.4
6	1.4
7	1.4
8	5
IC 102	
1	0
2	0
3	12
4	1.7
5	1.7
6	0
7	0
8	0
9	0
10	0
11	0
12	12
13	0
14	0
15	0
16	0
17	12
18	12
19	5
20	5
21	5
22	5
23	5
24	5
25	5
26	1.7
27	0
28	5
29	1.9
30	1.9
31	12
32	12
33	12
34	0
35	0
36	0
37	0
38	0
39	0
40	0
41	0
42	1.7
43	3.3
44	0
45	0

MODE PIN NO.	STATE
46	1.7
47	1.5
48	5
49	0
50	0
51	0
52	0
53	0
54	0
IC 103	
1	3.3
2	0
3	0
4	0
5	0
6	0
7	0
8	3.3
IC 104	
1	1.7
2	1.7
3	1.7
4	5
5	1.7
6	1.7
7	1.7
8	1.7
9	1.7
10	1.7
11	0
12	1.7
13	1.7
14	1.7
IC 105	
1	0
2	0
3	0
4	0
5	0
6	0
IC 106	
1	0
2	2.3
3	2.3
4	2.3
5	2.3
6	0
7	2.1
8	2.1
9	2.1
10	2.1
11	5
12	2.1
13	2.3
14	2.1

MODE PIN NO.	STATE
15	2.1
16	2.1
17	2.1
18	0
19	2.3
20	0
21	2.3
22	0
23	0
24	2.3
25	2.3
26	1.7
27	0
28	0
29	0
30	5
31	0
32	0
33	0
34	0
35	0
36	2.5
37	2.5
38	3.3
39	1.7
40	5
41	1.7
42	1.7
43	0
44	1.3
45	5
46	2.3
47	2.3
48	2.3
49	2.3
50	0
51	5
52	3.3
53	3.3
54	3.3
55	0
56	3.3
57	5
58	0
59	0
60	3.3
61	3.3
62	3.3
63	0
64	0
65	0
66	0
67	1.7
68	1.7
69	0

MODE PIN NO.	STATE
70	0
71	0
72	0
73	0
74	0
75	0
76	0
77	0
78	3.3
79	1.4
80	2.5
81	1.7
82	0
83	2.3
84	1.7
85	1.7
86	1.7
87	1.7
88	2.5
89	5
90	2.5
91	1
92	1.7
93	0.6
94	2
95	1.7
96	1.8
97	1.8
98	5
99	0
100	0
101	0
102	0
103	1
104	1.7
105	0
106	2.6
107	2.6
108	2.6
109	2.6
110	2.6
111	5
112	3
113	1.7
114	5
115	0.8
116	2.3
117	1
118	0
119	0
120	0
IC 107	
1	0
2	3.3
3	2.5

MODE PIN NO.	STATE
4	1.5
5	3
6	3
7	3
8	1.9
9	1.9
10	3.3
11	5
12	3
13	2.2
14	0
15	0
16	3.3
17	0
18	0
19	1.7
20	0
IC 108	
1	3.3
2	3.3
3	3.3
4	3.3
5	0
6	3.3
7	0
8	0
9	3.3
10	0
11	1.4
12	1.1
13	1.1
14	1.4
15	1.4
16	1.1

• IC BLOCK DIAGRAMS

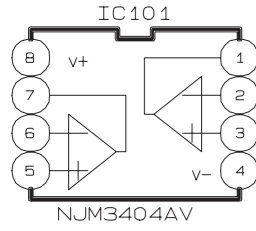

IC101_NJM3404AV

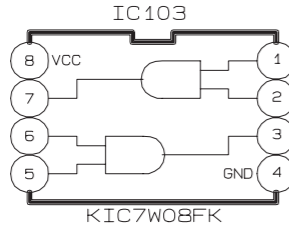

IC103_KIC7W08FK

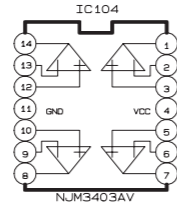

IC104_NJM3403AV

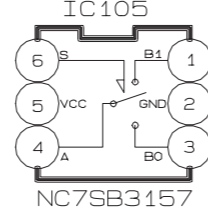

IC105_NC7SB3157

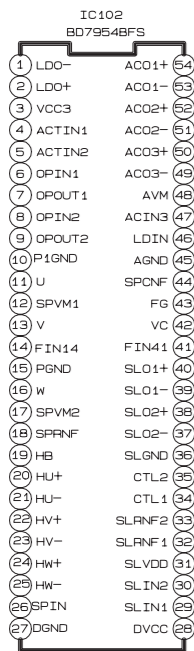

IC102_BD7954BFS

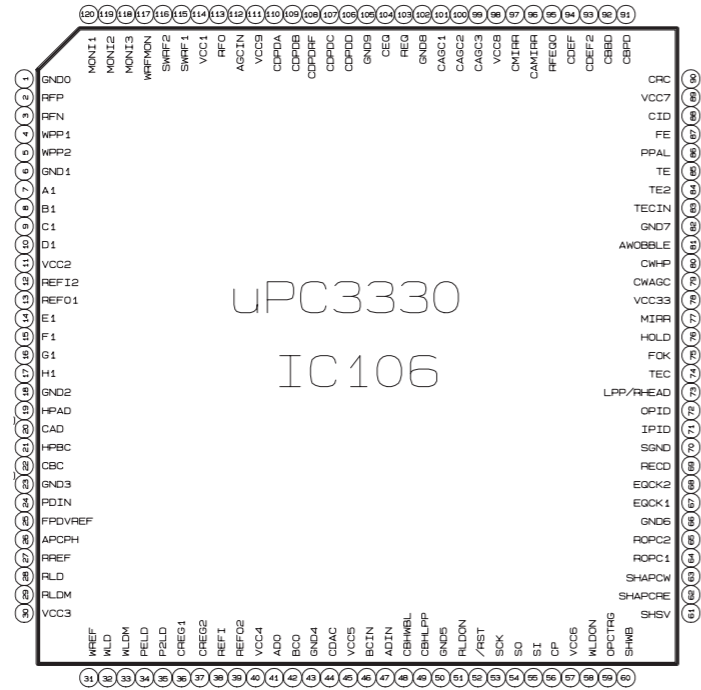

IC106_UPC3330

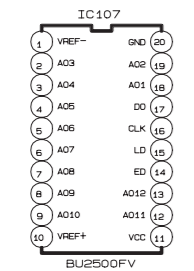

IC107_BU2500FV

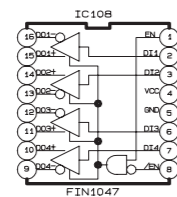

IC108_FIN1047

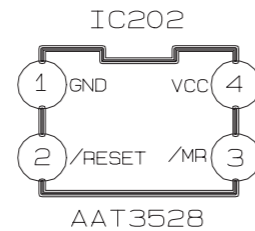

IC202_AAT3528

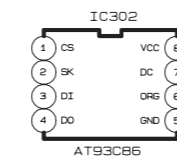

IC302_AT93C86

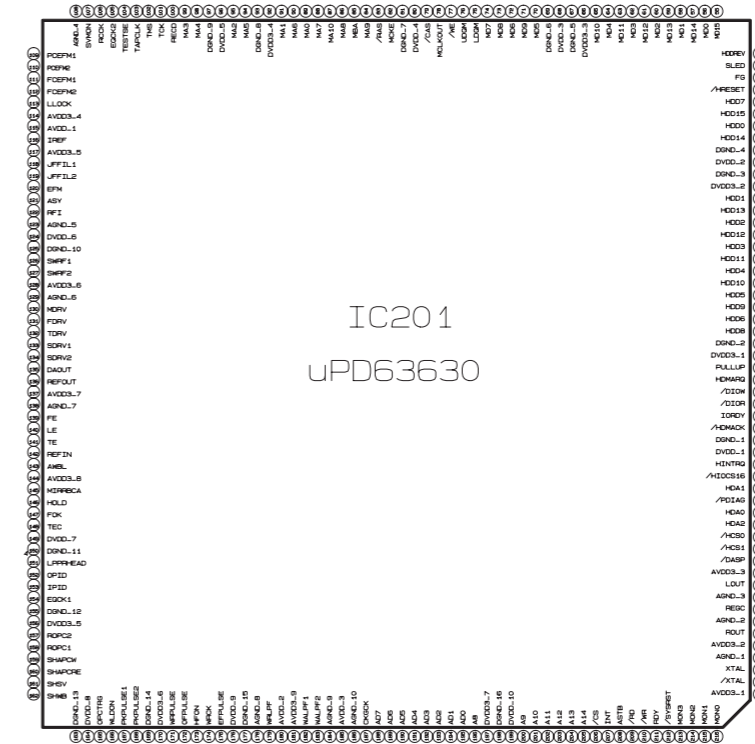

IC201_UPD63630

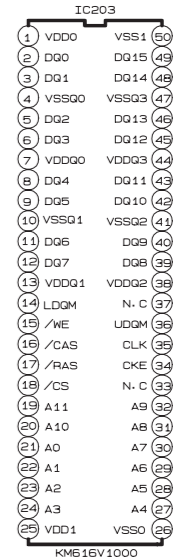

IC203_KM616V1000

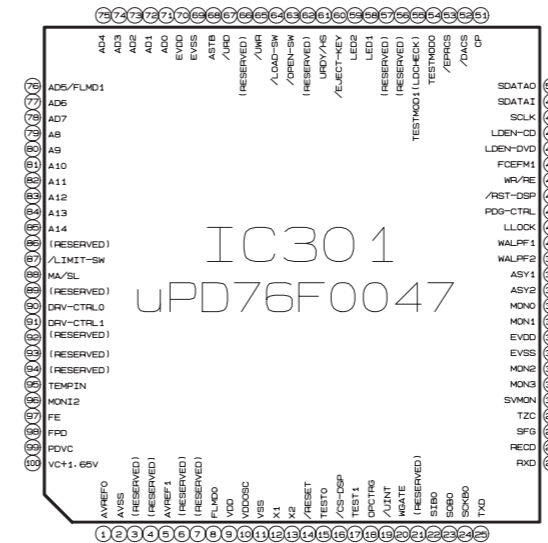

IC301_UPD76F0047

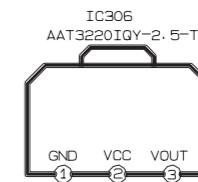

IC306_AAT3220IQY-2.5-T1

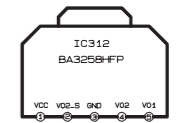

IC312_BA3258HFP

PRINTED CIRCUIT DIAGRAMS

1. MAIN P.C.BOARD

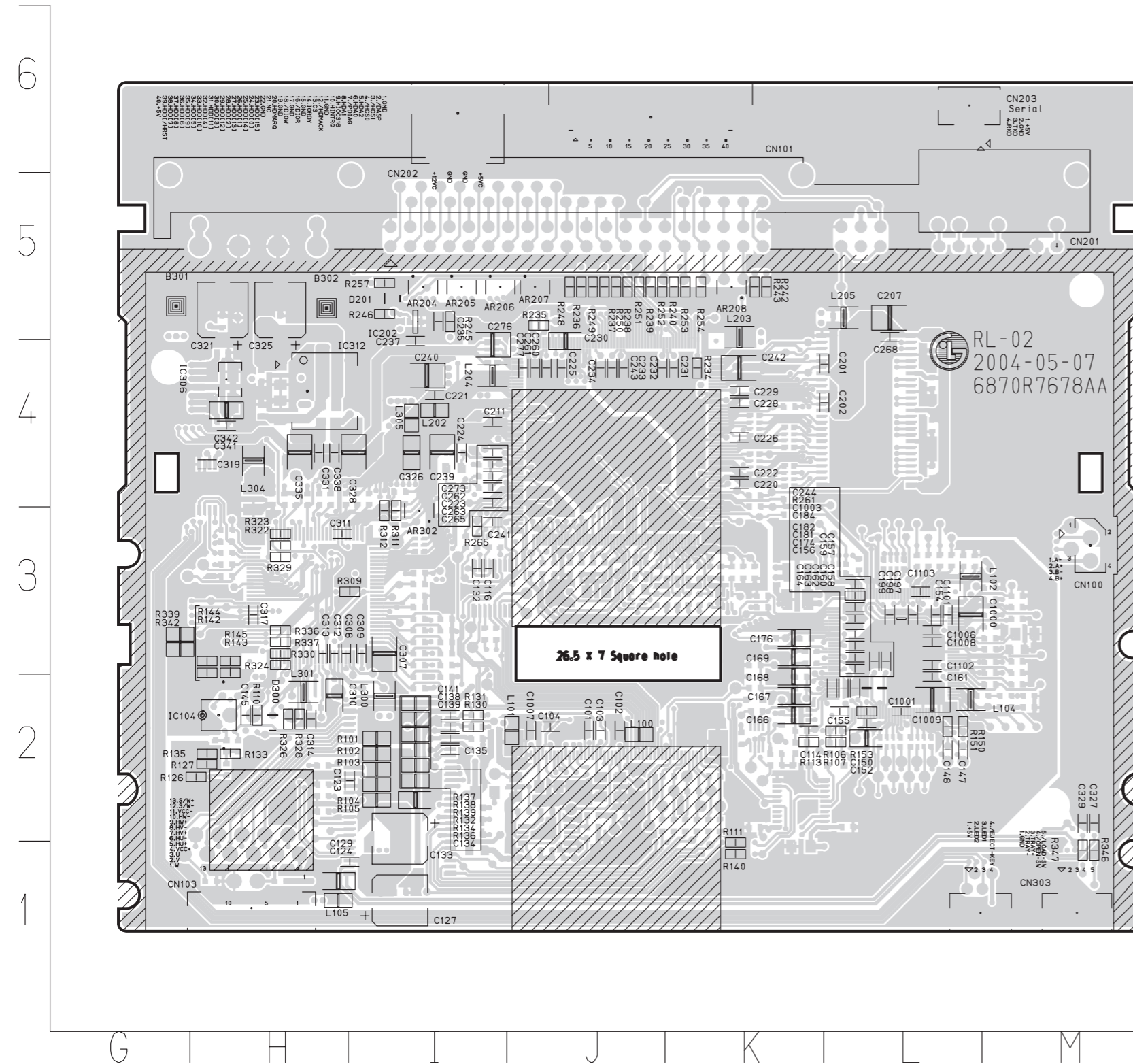

LOCATION GUIDE

AR204	I5	C154	L3	C234	J4	CN101	J6	ITC1150	I2	ITC2151	J5	L300	I2	R240	K5
AR205	I5	C155	L2	C235	I5	CN103	H1	ITC1152	I2	ITC2153	I5	L301	H2	R242	K5
AR206	I5	C156	L3	C237	I4	CN201	M5	ITC2001K4		ITC2154	I4	L304	H4	R243	K5
AR207	J5	C157	L3	C239	I4	CN202	I6	ITC2002L4		ITC2160	I3	L305	I4	R245	I5
AR208	K5	C158	L2	C240	I4	CN203	L6	ITC2003K4		ITC2161	I5	R101	I2	R246	I5
AR302	I3	C159	L3	C241	I3	CN303	M1	ITC2004L4		ITC2164	L3	R102	I2	R248	J5
B301	G5	C160	L2	C242	K4	D201	I5	ITC2005K4		ITC2165	L3	R103	I2	R249	J5
B302	H5	C161	L2	C243	J4	D300	H2	ITC2006L4		ITC3000H2		R104	I2	R250	J5
C1000	L3	C162	L2	C244	L3	IC104	H2	ITC2007L4		ITC3002I3		R105	I2	R251	J5
C1001	L2	C163	L2	C260	J4	IC202	I5	ITC2008K4		ITC3004K3		R106	L2	R252	J5
C1003	L3	C164	L2	C261	J4	IC306	H4	ITC2009L4		ITC3005H3		R107	L2	R253	K5
C1006	L3	C166	K2	C262	I4	IC312	H4	ITC2010K4		ITC3019I3		R110	H2	R254	K5
C1007	J2	C167	K2	C263	I4	ITC1000	I3	ITC2011L4		ITC3045H3		R111	K1	R257	I5
C1008	L3	C168	K2	C265	I4	ITC1003H2		ITC2012K4		ITC3047H3		R113	K2	R261	L3
C1009	L2	C169	K3	C268	L5	ITC1024H2		ITC2013L4		ITC3052H3		R126	H2	R265	I3
C101	J2	C174	L3	C273	I4	ITC1027G2		ITC2014K4		ITC3053I2		R127	H2	R309	I3
C102	J2	C176	K3	C276	I4	ITC1028H3		ITC2015L4		ITC3054H3		R130	I2	R311	I3
C103	J2	C181	L3	C277	J4	ITC1029H3		ITC2016K4		ITC3058I3		R131	I2	R312	I3
C104	J2	C182	L3	C307	I3	ITC1044L2		ITC2017L4		ITC3060H3		R132	I2	R322	H3
C1101	L3	C184	L3	C308	H3	ITC1049L3		ITC2018L4		ITC3062H3		R133	H2	R323	H3
C1102	L3	C197	L3	C309	I3	ITC1050L2		ITC2046M2		ITC3065H3		R134	I2	R324	H3
C1103	L3	C198	L3	C310	H2	ITC1068K2		ITC2047M2		ITC3066H3		R135	H2	R326	H2
C114	K2	C199	L3	C311	H3	ITC1078L2		ITC2048H3		ITC3067K2		R136	I2	R328	H2
C116	I3	C201	L4	C312	H3	ITC1081L3		ITC2049H3		ITC3068H3		R137	I2	R329	H3
C123	I2	C202	L4	C313	H3	ITC1082K3		ITC2050H2		ITC3069H3		R138	I2	R330	H3
C124	H1	C207	L5	C314	H2	ITC1088L3		ITC2065I3		ITC3071H2		R139	I2	R336	H3
C127	I1	C211	I4	C317	H3	ITC1089L3		ITC2078K4		ITC3073G3		R140	K1	R337	H3
C129	I1	C220	K4	C319	H4	ITC1098M3		ITC2102L3		ITC3075I3		R142	H3	R339	G3
C132	I3	C221	I4	C321	H5	ITC1101K2		ITC2105J4		ITC3076I3		R143	H3	R342	G3
C133	I2	C222	K4	C325	H5	ITC1103H3		ITC2117H3		ITC3077I3		R144	H3	R346	M1
C134	I2	C223	I4	C326	I4	ITC1104M3		ITC2136J5		ITC3078I3		R145	H3	R347	M1
C135	I2	C224	I4	C327	M2	ITC1110I2		ITC2137J5		L100	J2	R150	L2	TP256	L5
C138	I2	C225	J4	C328	I4	ITC1111I2		ITC2138J5		L101	J2	R151	L2	TP257	L5
C139	I2	C226	K4	C329	M2	ITC1112I2		ITC2139J5		L102	L3	R153	L2		
C141	I2	C228	K4	C331	H4	ITC1120L3		ITC2140J5		L104	L2	R234	K4		
C145	H2	C229	K4	C335	H4	ITC1121L3		ITC2141K5		L105	H1	R235	J5		
C147	L2	C230	J4	C338	H4	ITC1125L3		ITC2143K5		L202	I4	R236	J5		
C148	L2	C231	K4	C341	H4	ITC1141K1		ITC2146J4		L203	K5	R237	J5		
C150	L2	C232	J4	C342	H4	ITC1147H2		ITC2147K5		L204	I4	R238	J5		
C152	L2	C233	J4	CN100	M3	ITC1149H2		ITC2149K5		L205	L5	R239	J5		

LOCATION GUIDE

AR101	B2	C170	A2	C248	D3	IC103	C2	ITC1133	C3	ITC3015E3	R176	C3	R314	E4	TP121	B2	TP164	D3	TP247	C5	
AR102	B2	C171	A2	C249	C3	IC105	C2	ITC1134	C3	ITC3016E3	R177	B3	R315	E4	TP122	B2	TP165	D3	TP248	C5	
AR103	B3	C172	A3	C250	C3	IC106	B3	ITC1139	C3	ITC3018E2	R178	B3	R316	E4	TP123	B2	TP166	E2	TP249	C5	
AR201	C4	C173	A3	C251	E4	IC107	C2	ITC1140	D3	ITC3028E3	R179	B3	R317	F4	TP124	B2	TP167	F1	TP250	C5	
AR202	C4	C175	A3	C252	E4	IC108	E3	ITC1142	E1	ITC3031E2	R182	D1	R318	F2	TP125	B2	TP168	F2	TP251	C5	
AR203	C4	C177	A3	C253	E4	IC201	D4	ITC1143	C2	ITC3033E2	R183	D2	R319	F4	TP126	B2	TP169	F2	TP252	C5	
AR209	C4	C178	C3	C254	D3	IC203	B4	ITC1144	E2	ITC3035E2	R184	D2	R320	F4	TP127	B2	TP170	F2	TP253	C5	
AR210	E4	C179	A3	C255	C3	IC301	F3	ITC1148	F2	ITC3036E2	R185	E2	R321	F4	TP128	B2	TP201	D3	TP254	C5	
AR211	B3	C180	C3	C256	D3	IC302	F4	ITC2000B5		ITC3046F2	R186	E2	R325	F4	TP129	B2	TP202	C5	TP301	B1	
AR301	E3	C183	A3	C264	D3	ITC1004	B3	ITC2019C4		ITC3051F3	R188	C2	R327	F4	TP130	C2	TP203	C3	TP302	B1	
AR303	E3	C185	A3	C266	C3	ITC1006	D1	ITC2020C4		ITC3056B5	R189	C2	R331	F3	TP131	D2	TP204	B3	TP303	F2	
C100	F1	C186	A3	C267	C3	ITC1007	C2	ITC2021C4		ITC3061F3	R190	D2	R332	F3	TP132	A3	TP205	E3	TP304	F2	
C1002	C3	C187	A3	C269	C3	ITC1008	E3	ITC2022C4		ITC3070F3	R191	C2	R333	F3	TP133	A3	TP206	E3	TP305	A1	
C1011	D2	C188	A3	C270	C3	ITC1009	C1	ITC2024C4		ITC3072F3	R192	C2	R334	F3	TP134	A3	TP207	E4	TP306	F4	
C105	F2	C189	B2	C271	E4	ITC1011	C3	ITC2031C4		ITC3074F3	R193	C2	R335	F3	TP135	A3	TP208	F2	TP307	F2	
C106	F2	C190	A3	C272	E4	ITC1012	C2	ITC2035C4	L103	C3	R194	E3	R338	E3	TP136	C2	TP213	E5	TP308	F2	
C107	D2	C191	C1	C274	C3	ITC1016	E2	ITC2036C3	L106	E1	R195	E3	R343	F2	TP137	A2	TP215	E5	TP309	F2	
C108	D2	C192	A3	C275	C3	ITC1017	E2	ITC2038C3	L302	F4	R201	A2	R344	G2	TP138	F1	TP216	F3	TP310	F2	
C109	C2	C193	A3	C301	E3	ITC1018	F2	ITC2039C3	L303	F4	R202	A2	R345	A2	TP139	F2	TP217	F5	TP311	F2	
C110	C2	C194	A3	C302	E3	ITC1022	D1	ITC2051B3	Q201	D3	R203	B5	R348	C3	TP140	F1	TP218	E5	TP312	F3	
C1100	C2	C195	B3	C303	E3	ITC1035	B2	ITC2052B3	Q202	C3	R204	B3	R350	F4	TP141	F1	TP219	E5	TP313	F2	
C111	C2	C196	B3	C304	E3	ITC1048	B2	ITC2053B3	Q203	E4	R209	D3	R351	E5	TP142	F2	TP220	E5	TP314	F4	
C112	C2	C203	B4	C305	E2	ITC1054	C2	ITC2054B3	R100	F1	R210	D3	TP100	C2	TP143	F1	TP221	E5	TP315	E3	
C113	C2	C204	B4	C306	E2	ITC1057	B2	ITC2055B3	R108	F2	R214	C3	TP101	C2	TP144	F2	TP222	E5	TP316	E3	
C120	F2	C205	B4	C315	F4	ITC1059	C3	ITC2056B3	R109	C2	R215	D3	TP102	C2	TP145	F1	TP223	E5	TP317	A1	
C121	F2	C206	B4	C316	F4	ITC1061	C2	ITC2057B3	R112	C2	R216	C3	TP103	C2	TP146	F2	TP224	E5	TP320	A1	
C122	F2	C208	D3	C318	F4	ITC1067	A2	ITC2058C3	R114	A2	R217	E3	TP104	C2	TP147	F1	TP225	E5	TP321	A2	
C125	E1	C209	D3	C320	F5	ITC1073	F4	ITC2059B3	R115	C3	R218	E3	TP105	D2	TP148	F2	TP226	E5	TP322	A1	
C126	E2	C210	D3	C322	E3	ITC1077	C3	ITC2060C3	R116	F2	R219	C4	TP106	E3	TP149	F1	TP227	D5	TP323	A1	
C128	E2	C212	D3	C324	F5	ITC1085	A3	ITC2061C3	R117	F2	R220	C4	TP107	F3	TP150	G1	TP228	D5	TP324	A1	
C130	E2	C213	C3	C333	F4	ITC1086	C3	ITC2064D3	R124	D1	R221	E3	TP108	E3	TP151	E1	TP229	D5	TP328	A2	
C131	E2	C214	C3	C334	F4	ITC1087	B3	ITC2068C3	R125	C2	R226	C4	TP109	E3	TP152	E2	TP230	E4	X201	D5	
C136	E2	C215	C3	C336	F4	ITC1095	C2	ITC2074B4	R128	D2	R266	E3	TP110	E2	TP153	F2	TP231	D5	X300	F2	
C137	E2	C216	C3	C344	F4	ITC1102	F2	ITC2076C4	R146	C2	R301	E3	TP111	C2	TP154	C2	TP232	D5			
C140	D2	C217	C3	C345	F4	ITC1106	C2	ITC2085E4	R147	C2	R302	E3	TP112	C2	TP155	A3	TP233	D5			
C142	C2	C218	D3	C346	F4	ITC1107	A3	ITC2098C4	R148	B2	R303	E3	TP113	D2	TP156	A2	TP235	D5			
C143	D2	C219	D3	C347	F4	ITC1108	E1	ITC2110	E3	R149	B2	R304	E3	TP114	D2	TP157	A2	TP236	D5		
C144	D2	C227	E4	CN102	D2	ITC1109	E1	ITC2115	C5	R154	B2	R305	E2	TP115	D2	TP158	A2	TP238	D5		
C146	C2	C236	E5	D100	C2	ITC1113	B3	ITC2118	E5	R156	C3	R306	E2	TP116	B2	TP159	B2	TP240	D5		
C149	C2	C238	C3	D101	B2	ITC1114	C3	ITC2119	E5	R158	C2	R307	E3	TP117	B2	TP160	B2	TP242	D5		
C151	D2	C245	A2	D102	C2	ITC1122	B3	ITC2150	D5	R161	A3	R308	E3	TP118	G3	TP161	A2	TP243	D5		
C153	B2	C246	A2	IC101	D2	ITC1126	B3	ITC2163	B3	R162	C3	R310	E3	TP119	E2	TP162	A3	TP244	D5		
C165	C2	C247	D3	IC102	E2	ITC1130	C1	ITC3001	E3	R168	B3	R313	E3	TP120	B2	TP163	E4	TP246	C5		

SECTION 4 MECHANISM OF VCR PART(D-37)

CONTENTS

POSITION DRAWING OF DECK MECHANISM PARTS

- Top View4-1
- Bottom View4-1

DISASSEMBLY AND ASSEMBLY OF DECK MECHANISM

1. Disassembly of Drum assembly4-2
2. Disassembly of Plate top disassembly 4-4
3. Holder Assembly CST4-4
4. Disassembly of Gear Assembly
Rack F/L4-4
5. Opener Door4-4
6. Arm Assembly F/L4-4
7. Lever Assembly S/W4-4
8. Motor Assembly L/D4-5
9. Gear Wheel4-5
10. Arm Assembly Cleaner4-5
11. Head F/E4-5
12. Base Assembly A/C Head4-5
13. Brake Assembly T4-6
14. Arm Assembly Tension4-6
15. Reel S / Reel T4-6
16. Base Assembly P44-7
17. Opener Lid4-7
18. Arm Assembly Pinch4-7
19. Arm T/up4-7
20. Supporter, Capstan4-8
21. Belt Capstan/Motor Capstan4-8
22. Lever F/R4-8
23. Clutch Assembly D374-8
24. Gear Drive/Gear Cam4-9
25. Gear Sector4-9
26. Brake Assembly Capstan4-9
27. Plate Slider4-9
28. Lever Tension4-9
29. Lever Spring4-9
30. Lever Brake4-9
31. Gear Assembly P2/Gear Assembly P3 ...4-10
32. Base Assembly P2/Base Assembly P3 ...4-10
33. Base Loading4-10
34. Base Tension4-11
35. Arm Assembly Idler Jog4-11

DECK MECHANISM ADJUSTMENT

- Fixtures and tools for service4-12
- 1. Mechanism Assembly Mode Check4-13
- 2. Previous Preparation for
Deck Adjustment4-14
- 3. Torque Measuring4-14
- 4. Guide Roller Height Adjustment4-15
 - 4-1. Prior Adjustment4-15
 - 4-2. Fine Adjustment4-15
- 5. Audio/Control (A/C) Head Adjustment4-16
 - 5-1. Prior Adjustment4-16
 - 5-2. Tape Path Check between Pinch
Roller and Take-up Guide4-17
 - 5-3. Fine Adjustment
(Azimuth Adjustment)4-17
- 6. X-distance Adjustment4-17
- 7. Adjustment after Drum Assembly
(Video Heads)4-18
- 8. Tachometer Adjustment of
Deck Assembly4-18
 - 8-1. Check of Audio, RF Normalization
Time (Locking Time) in Play after
CUE or REV4-18
 - 8-2. Check of Tape Curl and
Jam Status4-18

PROTECTION, MAINTENANCE AND CHECK OF VIDEO FUNCTION

1. Checking Points before Repair4-19
2. Essential Check and Repair4-20
3. Regular Check and Repair4-20
4. Tools for Check and Repair4-20
5. Maintenance Process4-20
 - 5-1. Removal of Foreign Materials4-20
 - 5-2. Grease Application4-21

TROUBLESHOOTING GUIDE

1. Deck Mechanism4-23
2. Front Loading Mechanism4-26

EXPLODED VIEWS

1. Front Loading Mechanism Section4-28
2. Moving Mechanism Section(1)4-29
3. Moving Mechanism Section(2)4-30

POSITION DRAWING OF DECK MECHANISM PARTS

• Top View

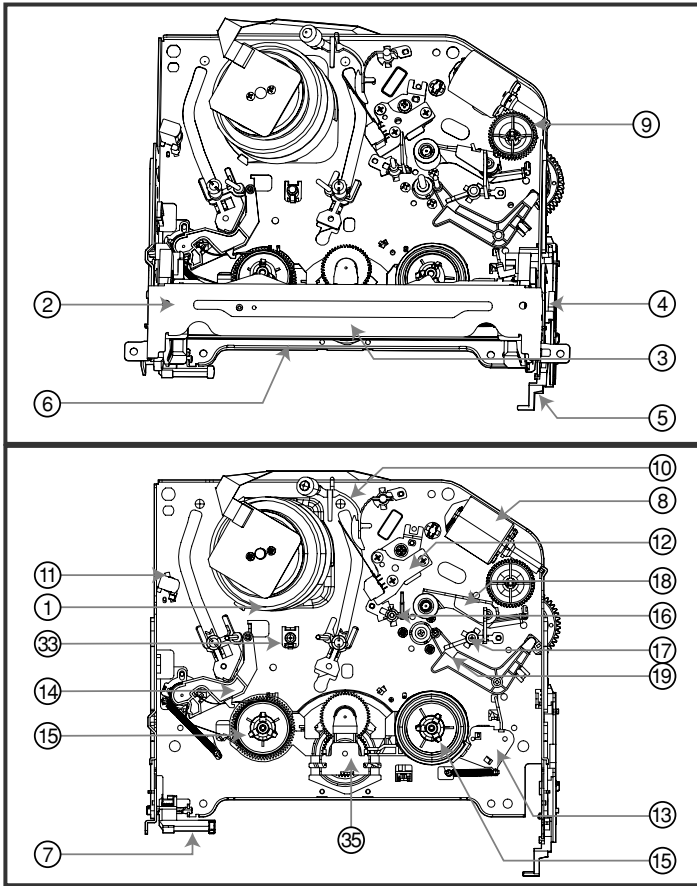

• Bottom View

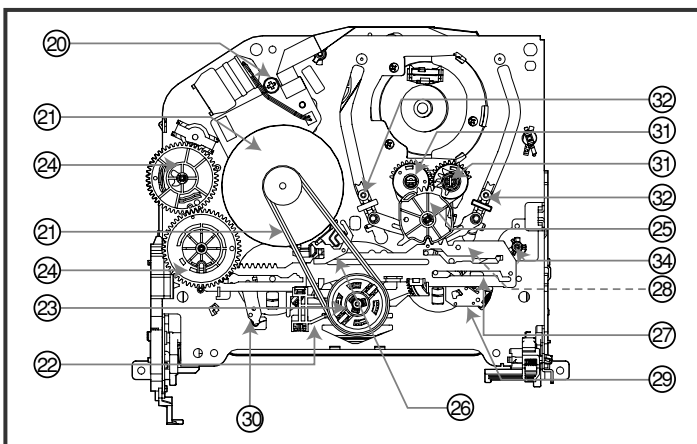

Order Of Dis- assembled Parts firstly Disassembled	Part	Fixing Type	Ref. Draw- ings	Posi tion
	1 Drum Assembly	3 screws	A-1	T
	2 Plate Top	2 hooks	A-2	T
2	3 Holder Assembly CST	6 chasses	A-2	T
2,3	4 Gear Assembly Rack F/L	1 hook	A-2	T
2,3,4	5 Opener Door	Chassis Hole	A-2	T
2,3,4,5	6 Arm Assembly F/L	Chassis Hole	A-2	T
	7 Lever Assembly S/W	Chassis Hole, 1 hook	A-2	T
	8 Motor Assembly L/D	1 screw	A-3	T
	9 Gear Wheel	2 hooks	A-3	T
	10 Arm Assembly Cleaner	Chassis Embossing	A-3	T
	11 Head F/E	Chassis Embossing	A-3	T
	12 Base Assembly A/C Head	1 screw	A-3	T
2,3	13 Brake Assembly T	1 hook	A-4	T
2,3	14 Arm Assembly Tension	1 hook	A-4	T
2,3,13,14	15 Reel S / Reel T	Shaft	A-4	T
	16 Base Assembly P4	Chassis Embossing	A-5	T
	17 Opener Lid	Chassis Embossing	A-5	T
17	18 Arm Assembly Pinch	Shaft	A-5	T
17	19 Arm T/up	1 hook	A-5	T
	20 Supporter, capstan	Chassis Hole	A-6	B
17,18	21 Belt Capstan/Motor Capstan	3 screws	A-6	B
	22 Lever F/R	Locking Tab	A-6	B
21, 22	23 Clutch Assembly D37	Washer	A-6	B
	24 Gear Drive/Gear Cam	Washer/Hook	A-7	B
	25 Gear Sector	Hook	A-7	B
21	26 Brake Assembly Capstan	Chassis Hole	A-7	B
21,22,23, 24,25,26	27 Plate Slider	Chassis Guide	A-7	B
21,22,23, 24,25,26,27	28 Lever Tension	1 Hook	A7	B
21,22,23, 24,25,26,27	29 Lever Spring	1 Hook	A-7	B
21,22,23, 24,25,26,27	30 Lever Brake	1 Hook	A-7	B
25	31 Gear Assembly P2/ Gear Assembly P3	Bass	A-8	B
2, 3, 14, 25, 31	32 Base Assembly P2 /Base Assembly P3	6 Chasses	A-8	B
25, 31	33 Base Loading	3 Hooks	A-8	B
2,3,14	34 Base Tension	Chassis Embossing	A-9	T
	35 Arm Assembly Idler Jog	Locking Tab	A-9	T

T:Top, B:Bottom

NOTE : Assembly order is a reverse of disassembly order.

- (1) For assembly, check the assembly mode is accurate.
- (2) Parts firstly disassembled indicate parts firstly disassembled in disassembly of related parts.

DISASSEMBLY AND ASSEMBLY OF DECK MECHANISM

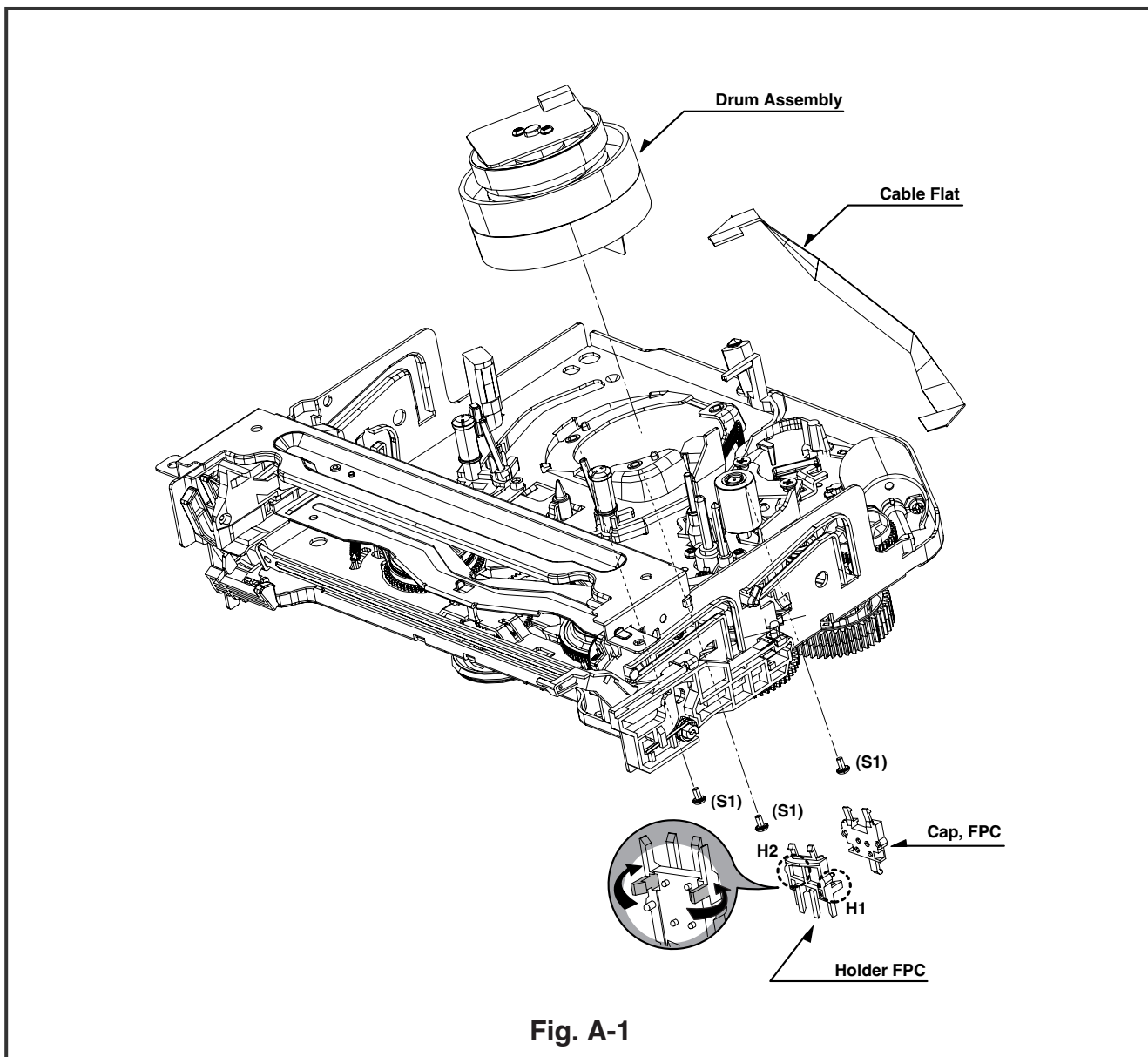
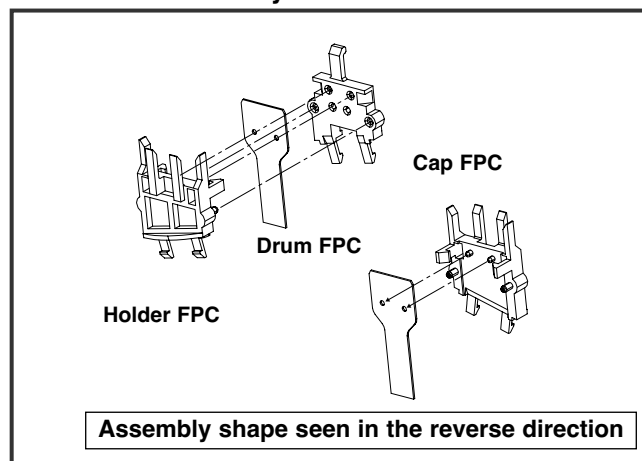

Fig. A-1

1. Disassembly of Drum Assembly (Figure A-1)

- 1) Separate cable flat from the Drum FPC and the Capstan Motor.
- 2) Release 3 screws (S1) on the bottom side of the chassis, and separate the drum assembly.
- 3) Release the hooks (H1, H2) and separate both the holder FPC and the Cap FPC (disassemble if necessary).

Cautions in assembly of FPC



DISASSEMBLY AND ASSEMBLY OF DECK MECHANISM

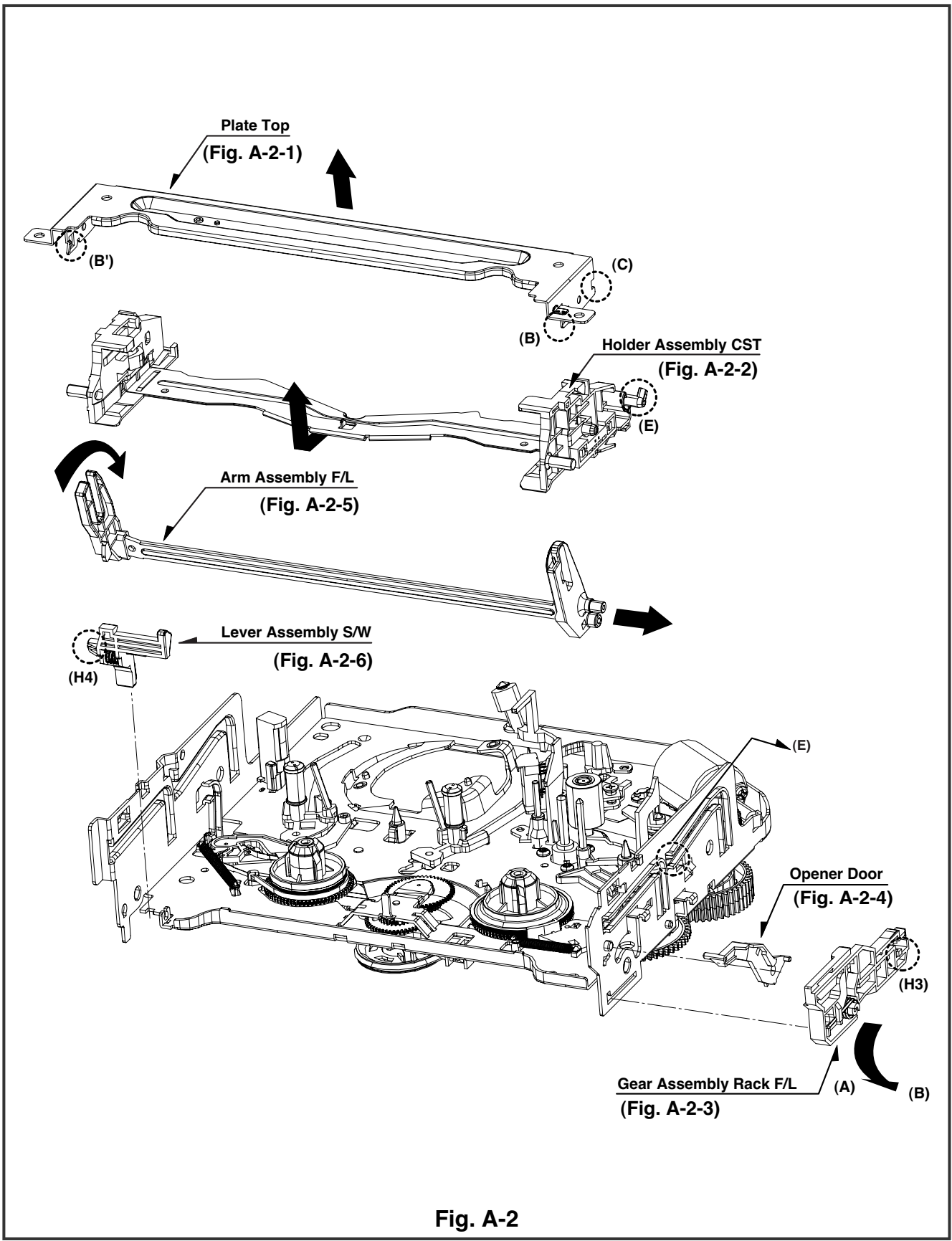

Fig. A-2

DISASSEMBLY AND ASSEMBLY OF DECK MECHANISM

2. Disassembly of Plate Top (Fig. A-2-1)

- 1) Separate the right part while leaning back the (B) part of the plate top toward the arrow direction.
- 2) Separate the left part while leaning back the (B') part of the plate top toward the arrow direction.
(Tool used: Tool such as (-) driver, auger, etc with pointed or flat end)

CAUTIONS

Assemble while pressing the (C), (C') part after corresponding them as in drawing.

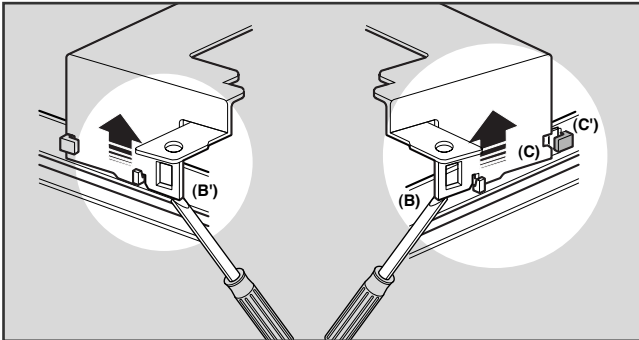

3. Holder Assembly CST (Fig. A-2-2)

- 1) Firstly separate the left part from the groove on the (D) part of chassis while moving the holder assembly CST toward the arrow direction.

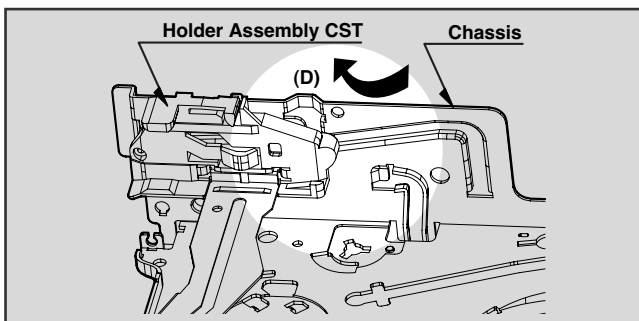

- 2) Separate the right part from each groove of chassis

CAUTIONS

Assemble by inserting the left part after firstly inserting the (E) part of the holder assembly CST into the groove on the (E') part of chassis.

4. Disassembly of Gear Assembly Rack F/L (Fig. A-2-3)

- 1) Separate the hook (H3) while leaning ahead the hook (3) after moving the gear assembly rack F/L toward the arrow (A) direction.
- 2) Separate the gear assembly rack F/L toward the arrow (B) direction.

CAUTIONS

For the assembly, correspond the gear part of gear assembly rack F/L to the gear drive.

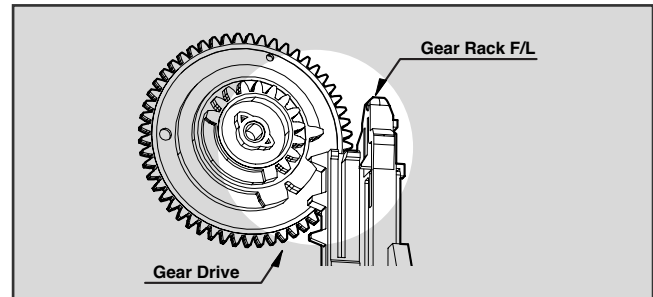

5. Opener Door (Fig. A-2-4)

- 1) Separate the opener door ahead from the guide hole of chassis while turning it clockwise.

6. Arm Assembly F/L (Fig. A-2-5)

- 1) Firstly separate the left part of the arm assembly F/L from the groove of chassis while pushing the arm assembly F/L toward the arrow direction.
- 2) Separate the right part from the groove of chassis.

7. Lever Assembly S/W (Fig. A-2-6)

- 1) Separate the lever assembly S/W while pushing it toward the arrow direction after removing the hook (4) on the left side of chassis.

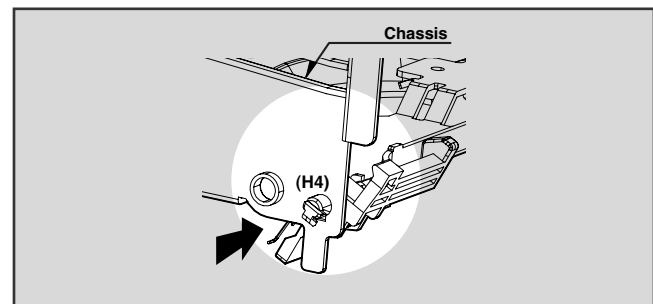

DISASSEMBLY AND ASSEMBLY OF DECK MECHANISM

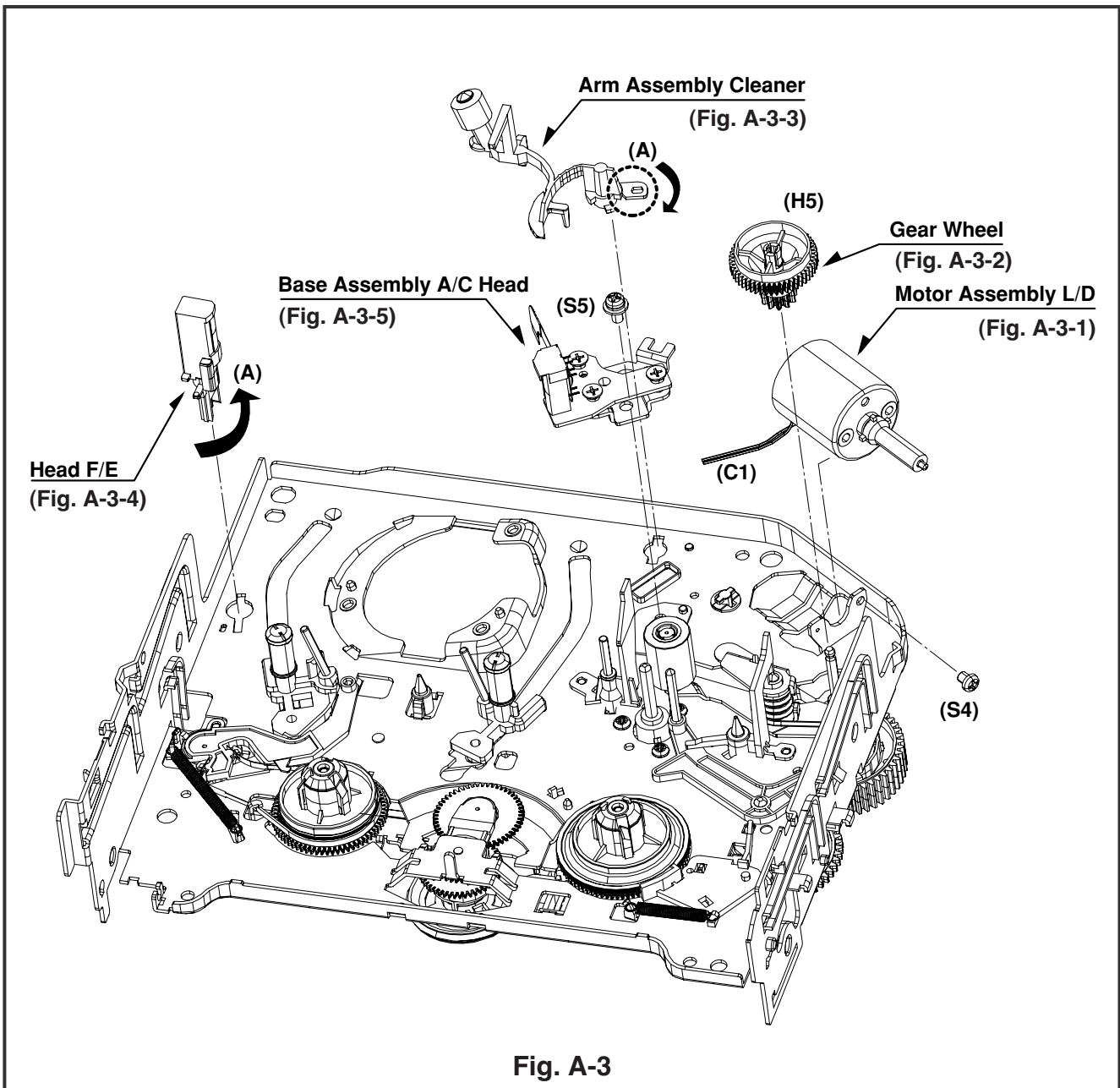

Fig. A-3

8. Motor Assembly L/D (Fig. A-3-1)

- 1) Take the connector (C1) connected to the Capstan motor PCB out.
- 2) Remove a screw (S4) of the chassis (S4) and step backward, and disassemble it while holding it up.

9. Gear Wheel (Fig. A-3-2)

- 1) Release the hook (H5) of the gear wheel and disassemble it upward.

10. Arm Assembly Cleaner (Fig. A-3-3)

- 1) Separate the (A) part of Fig. A-3-1 from the embossing of chassis, and hold it up while turning it anti-clockwise.

11. Head F/E (Fig. A-3-4)

- 1) Separate the (A) part of the head F/E from the embossing of chassis, and hold it up while turning it anti-clockwise.

12. Base Assembly A/C Head (Fig. A-3-5)

- 1) Release a screw (S5) and disassemble while holding it up.

DISASSEMBLY AND ASSEMBLY OF DECK MECHANISM

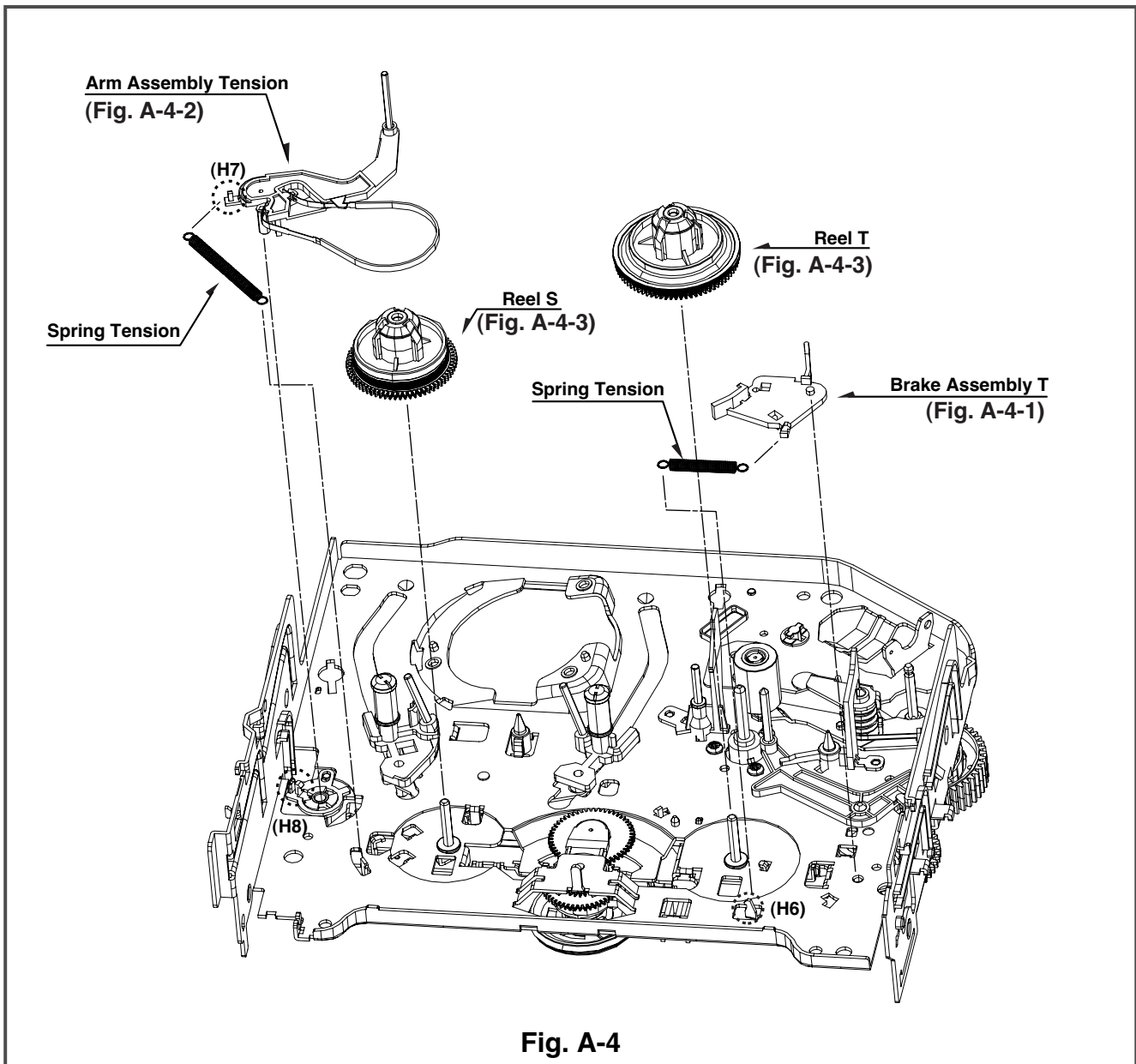

Fig. A-4

13. Brake Assembly T (Fig. A-4-1)

- 1) Release the spring tension from the lever spring hook (H6).
- 2) Disassemble the brake assembly T while holding it upward.

14. Arm Assembly Tension (Fig. A-4-2)

- 1) Release the spring tension the hook (H7) from the arm assembly tension.
- 2) After releasing the hook (H8) of the base tension, separate it while holding it up.

CAUTIONS

Spring used for both brake assembly T and arm assembly tension is used (2EA used).

15. Reel S/Reel T (Fig. A-4-3)

- 1) Disassemble the reel S/ reel T while holding it up (comparison between Reel S and Reel T)

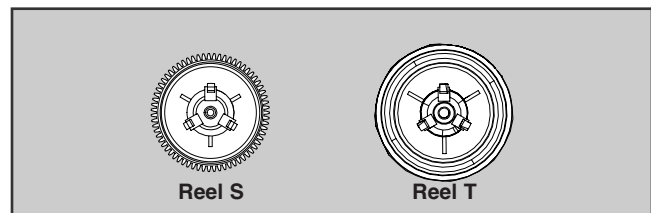

DISASSEMBLY AND ASSEMBLY OF DECK MECHANISM

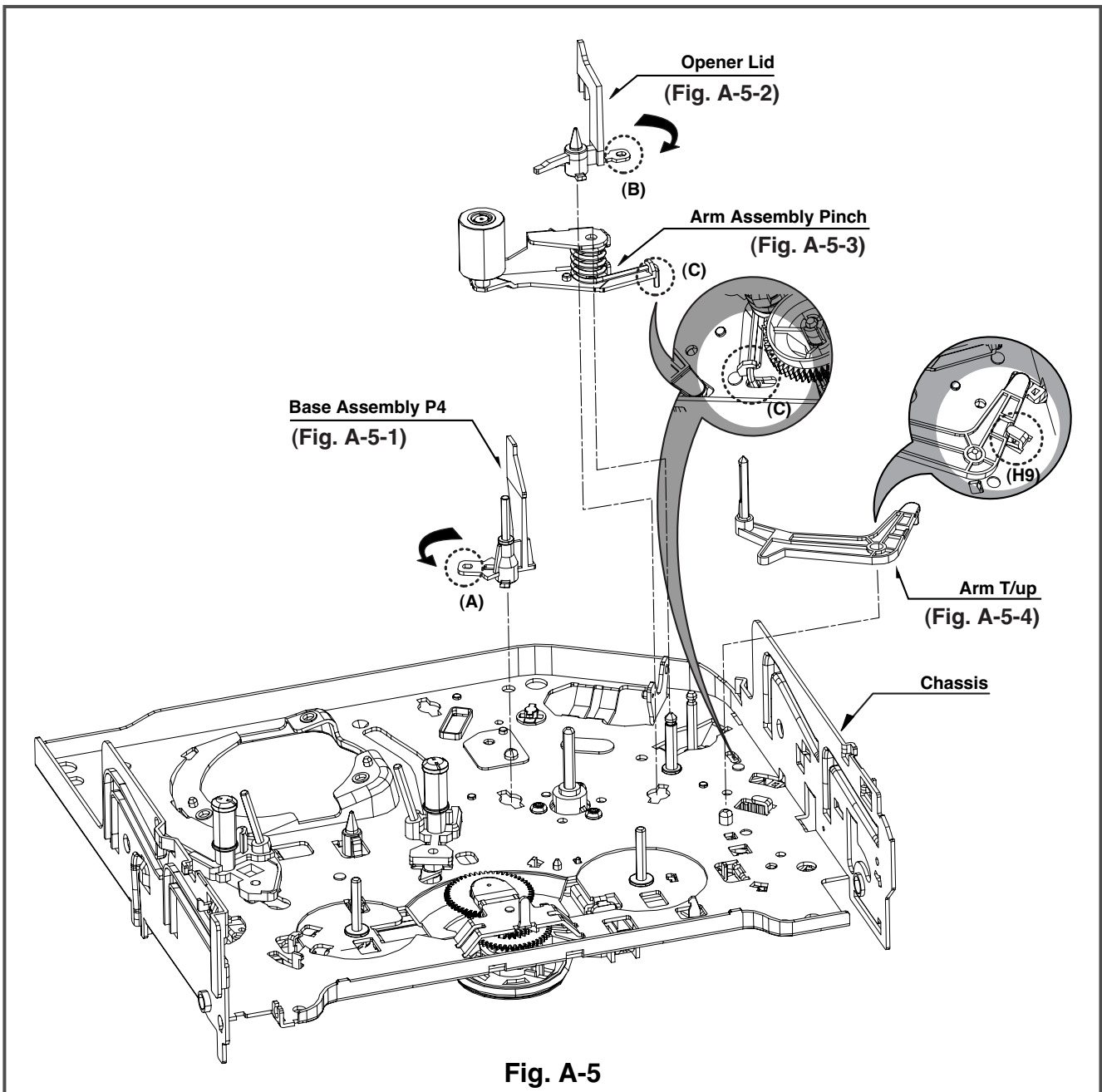

Fig. A-5

16. Base Assembly P4 (Fig. A-5-1)

- 1) Release the (A) part of the base assembly P4 from the embossing of chassis.
- 2) Hold the base assembly P4 up while turning it anti-clockwise.

17. Opener Lid (Fig. A-5-2)

- 1) Release the (B) part of the opener lid from the embossing of chassis.
- 2) Disassemble the opener lid upward while turning it anti-clockwise.

18. Arm Assembly Pinch (Fig. A-5-3)

- 1) Hold the arm assembly pinch up.

19. Arm T/up (Fig. A-5-4)

- 1) Turn the arm T/up to release the anchor jaw (H9) part of chassis and then hold it upward.

CAUTIONS

For the assembly, check the (C) part of the arm assembly pinch is assembled as in drawing.

- REVERSE THE MECHANISM.

DISASSEMBLY AND ASSEMBLY OF DECK MECHANISM

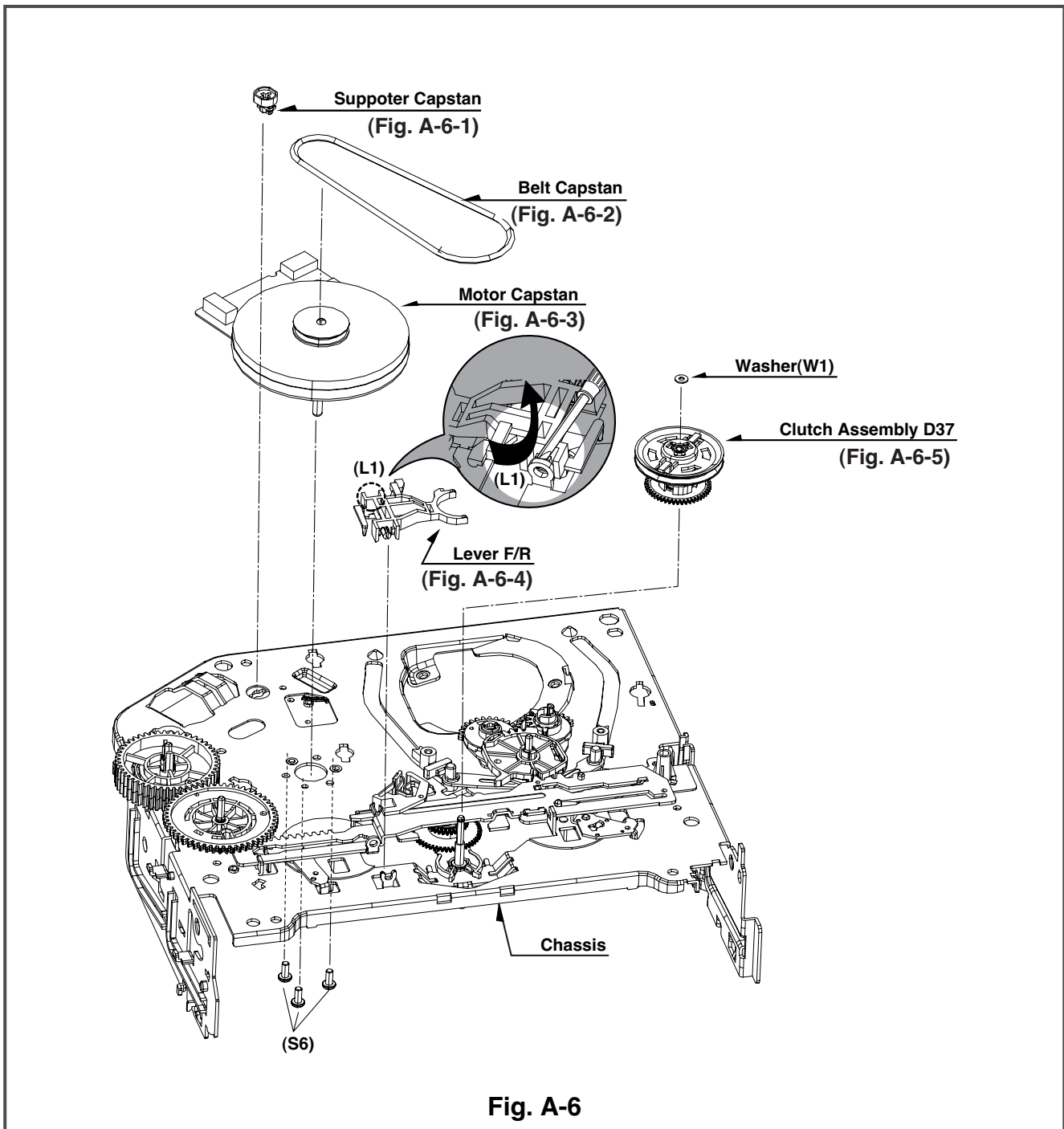

Fig. A-6

20. Supporter, Capstan (Fig. A-6-1)

- 1) Turn the supporter and Capstan by 90 deg. clockwise with a driver for disassembly.

21. Belt Capstan (Fig. A-6-2) / Motor Capstan (Fig. A-6-3)

- 1) Separate the belt Capstan.
- 2) Undo 3 screws (S6) on the bottom side of chassis and disassemble it upward.

22. Lever F/R (Fig. A-6-4)

- 1) Release the locking tab (L1) and then disassemble it upward.

23. Clutch Assembly D37 (Fig. A-6-5)

- 1) Remove the washer (W1) and then disassemble it upward.

DISASSEMBLY AND ASSEMBLY OF DECK MECHANISM

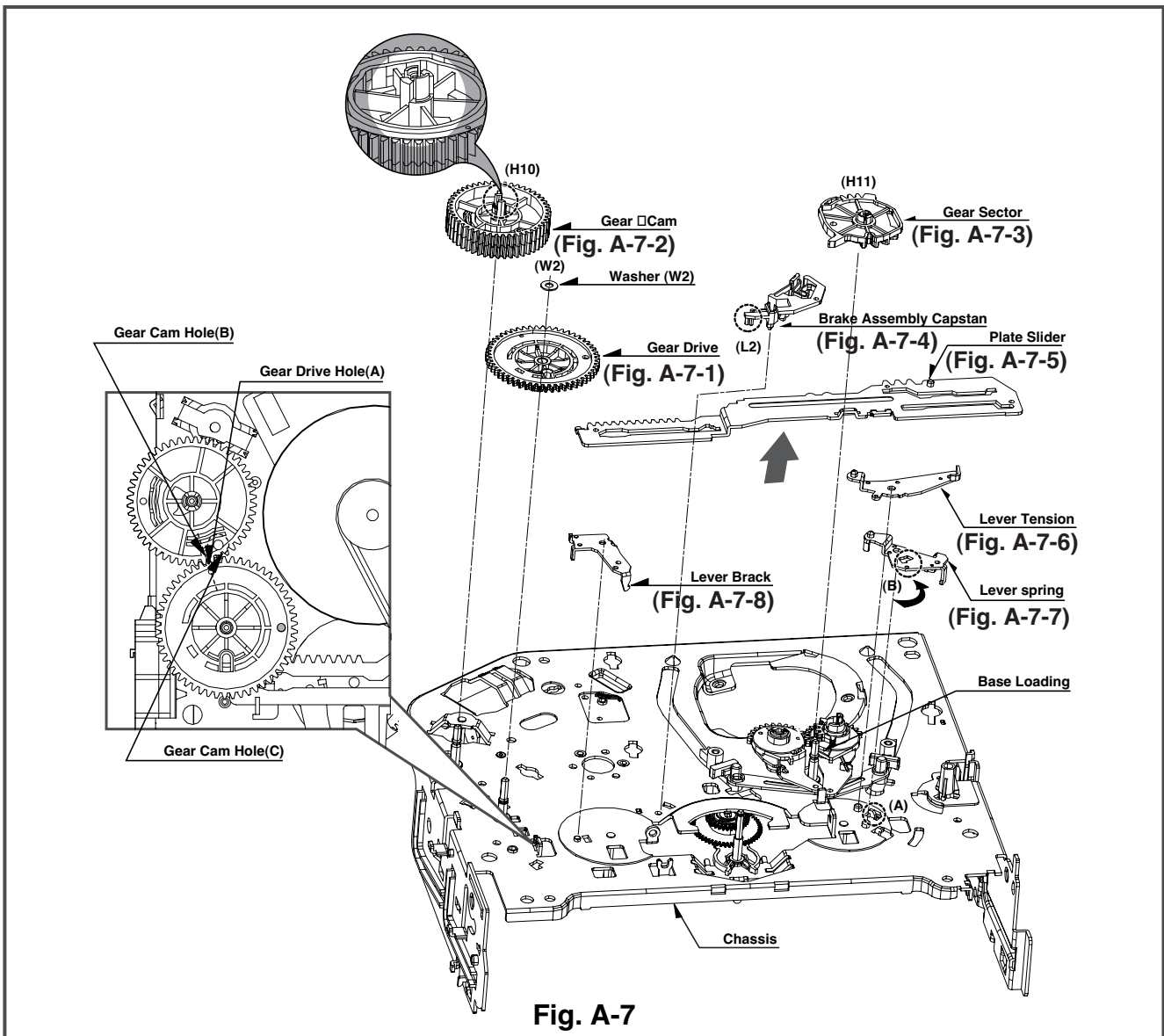

Fig. A-7

24. Gear Drive (Fig. A-7-1)/ Gear Cam (Fig. A-7-2)

- 1) Remove the washer (W2) and then disassemble the gear drive.
- 2) Release the hook (H10) of the gear cam and then disassemble it upward.

CAUTIONS

For the assembly, adjust both the gear driver hole (A) and the gear cam hole (B) straightly and then correspond the gear cam hole (C) to the chassis hole.

25. Gear Sector (Fig. A-7-3)

- 1) Release the hook (H11) of the gear sector and then hold the gear sector upward.

26. Brake Assembly Capstan (Fig. A-7-4)

- 1) Release the locking tab (L2) on the bottom side of the plate slider and then disassemble it upward.

27. Plate Slider (Fig. A-7-5)

- 1) Disassemble the plate slider while holding it up.

28. Lever Tension (Fig. A-7-6)

- 1) Release the lever tension from the guide (A) of chassis while turning it anti-clockwise.
- 2) Disassemble the lever tension while holding it up.

29. Lever Spring (Fig. A-7-7)

- 1) Release the (B) part of the lever spring from the guide (A) of chassis while turning it anti-clockwise.
- 2) Disassemble the lever tension while holding it up.

30. Lever Brake (Fig. A-7-8)

- 1) Disassemble the lever brake while holding it up.

DECK MECHANISM DISASSEMBLY

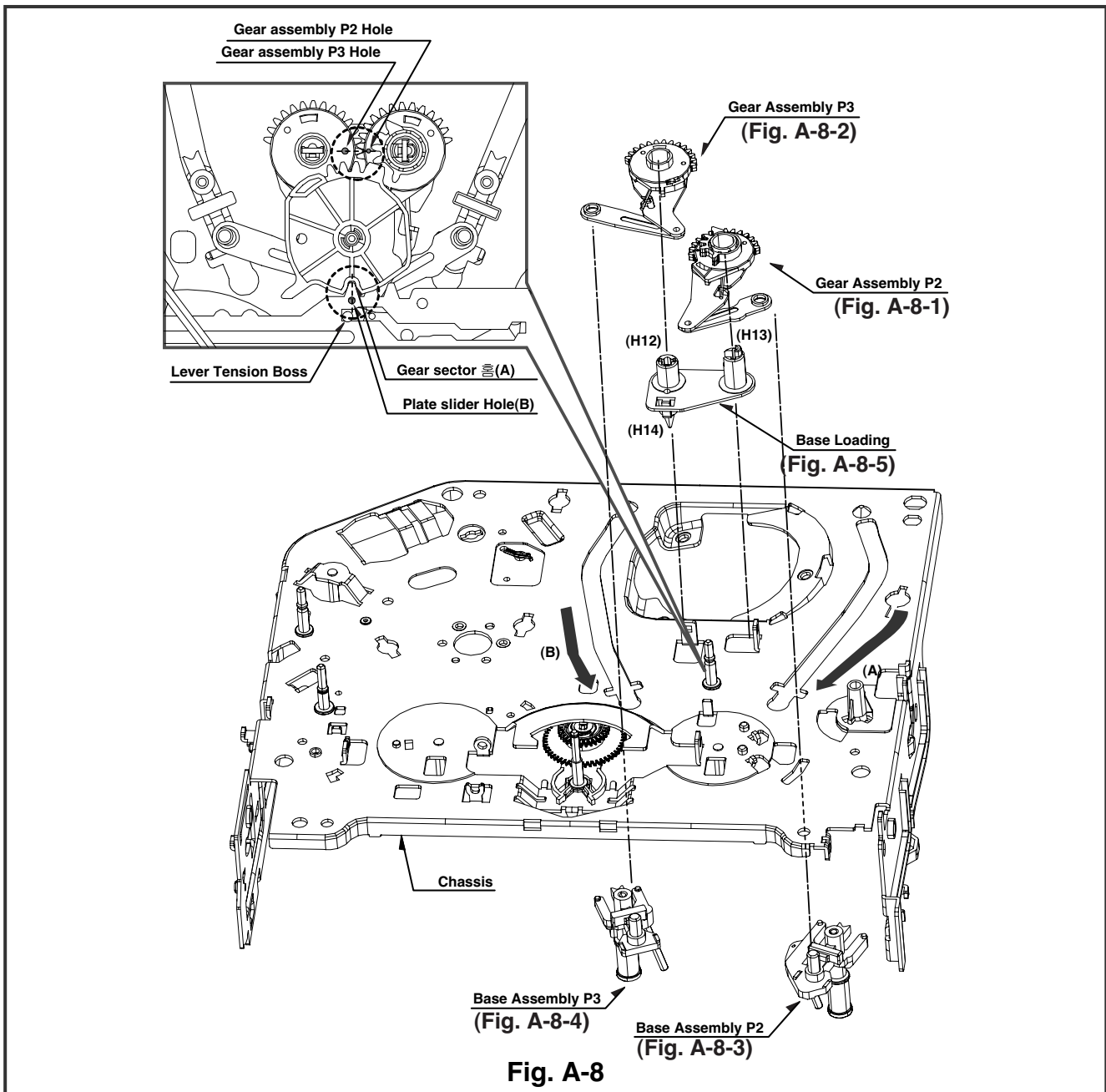

Fig. A-8

31. Gear Assembly P2 (Fig. A-8-1)/ Gear Assembly P3 (Fig. A-8-2)

- 1) Hold the gear assembly P2 upward.
- 2) Hold the gear assembly P3 upward.

CAUTIONS

For the assembly, check the holes of both the gear assembly P2 and the P3 are adjusted straightly, and then correspond the gear section groove (A) to the plate slider hole (B).

32. Base Assembly P2 (Fig. A-8-3)/ Base Assembly P3 (Fig. A-8-4)

- 1) Disassemble the base assembly P2 downward while moving it toward the arrow (A) direction along with the guide hole of chassis.
- 2) Disassemble the base assembly P2 downward while moving it toward the arrow (B) direction along with the guide hole of chassis.

33. Base Loading (Fig. A-8-5)

- 1) Release 3 hooks (H12, 13, 14) of the base loading, and then disassemble them upward.
- Reverse the mechanism.

DISASSEMBLY AND ASSEMBLY OF DECK MECHANISM

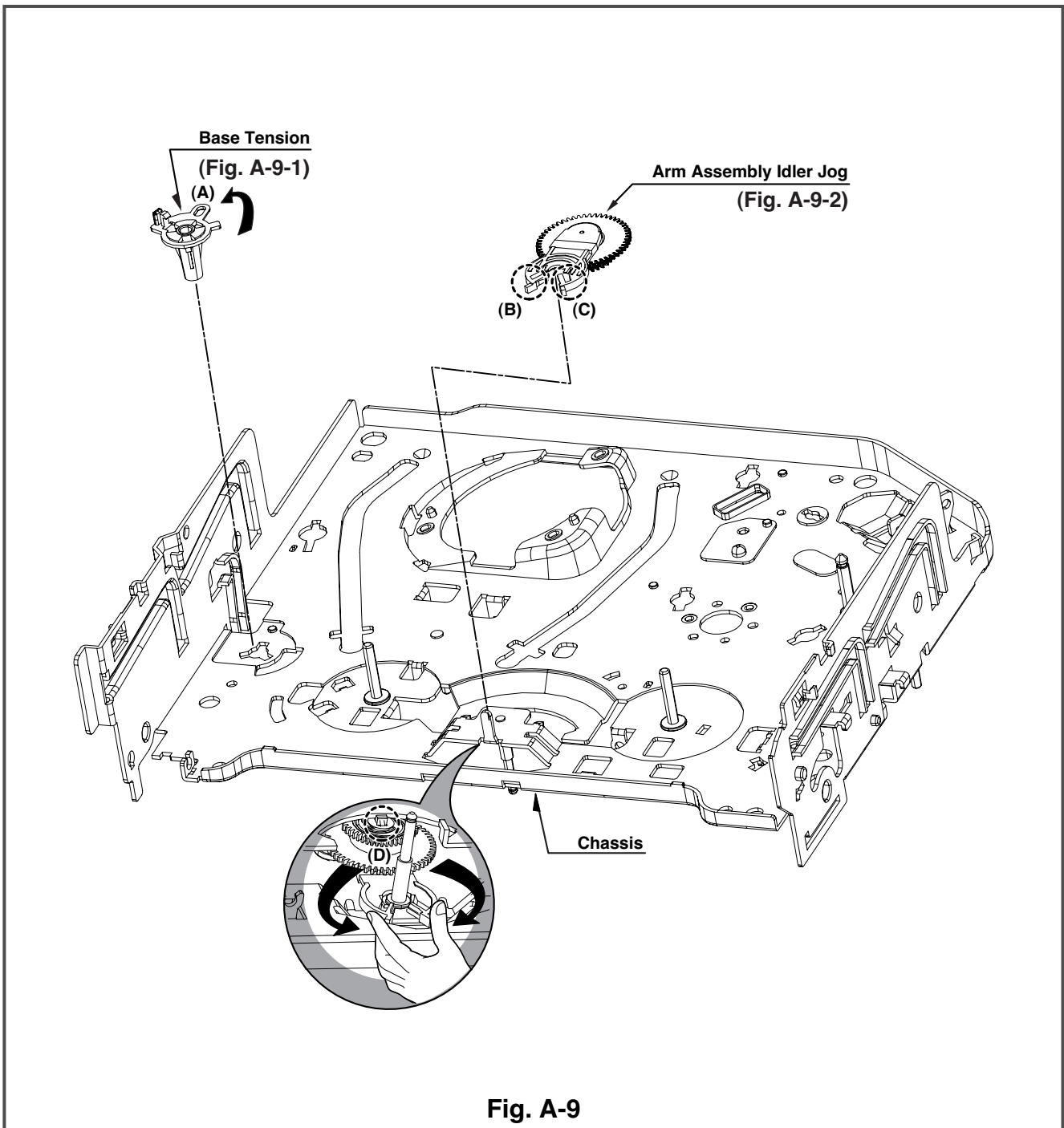

Fig. A-9

34. Base Tension (Fig. A-9-1)

- 1) Release the (A) part of the base tension from the embossing of chassis.
- 2) Hold the base tension upward while turning it anti-clockwise.

35. Arm assembly Idler Jog (Fig. A-9-2)



- 1) Push both (B), (C) parts in Fig. A-9-2 toward the arrow direction.
- 2) Disassemble the arm assembly idler upward.

CAUTIONS

Take care to ensure that the (D) part in the drawing is not hung to chassis in disassembly.

DECK MECHANISM ADJUSTMENT

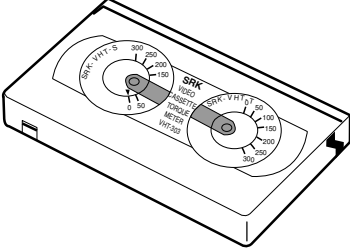
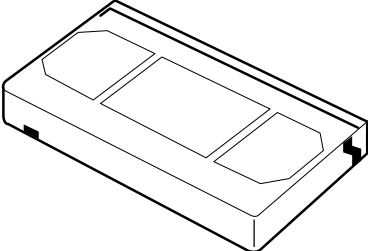
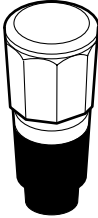
• Fixtures and Tools for Service

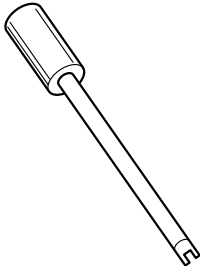
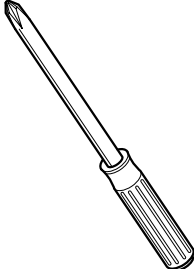
<p>1. Cassette Torque Meter SRK-VHT-303(Not SVC part) PHILIPS Part No: 996500013165</p>  <p>The image shows a rectangular cassette torque meter with two circular gauges on top. The left gauge is labeled 'SRK-VHT-3' and the right is 'SRK-VHT-1'. Both have scales from 0 to 300. The device is shown from a perspective view.</p>	<p>2. Alignment tape PHILIPS Part No NTSC:99650013166 PAL:996500013166</p>  <p>The image shows a rectangular alignment tape with a central slot and two side tabs. It is shown from a perspective view.</p>	<p>3. Torque gauge 600g.Cm ATG PHILIPS Part No: 996500013167</p>  <p>The image shows a cylindrical torque gauge with a hexagonal top and a black base. It is shown from a perspective view.</p>
<p>4. Torque gauge adaptor PHILIPS Part No: 996500013168</p>  <p>The image shows a small cylindrical adaptor with a central hole and a small protrusion on top. It is shown from a perspective view.</p>	<p>5. Post height adjusting driver PHILIPS Part No: 996500013169</p>  <p>The image shows a long, thin driver with a cylindrical handle and a small hook-like tip. It is shown from a perspective view.</p>	<p>6. + Type driver (ø5)</p>  <p>The image shows a standard Phillips screwdriver with a long handle and a Phillips bit. It is shown from a perspective view.</p>

DECK MECHANISM ADJUSTMENT

1. Mechanism Assembly Mode Check

Purpose of adjustment : To make tools normally operate by positioning tools accurately.

Fixtures and tools used	VCR (VCP) status	Checking Position
• Blank Tape (empty tape)	• Eject Mode (with cassette withdrawn)	• Mechanism and Mode Switch
1) Turn the VCR on and take the tape out by pressing the eject button. 2) Separate both top cover and plate top, and check both the hole (A) of gear cam and the hole (A') of chassis correspond (Fig. C-2). 3) If it is done as in the paragraph 2): Turn the gear cam after mantling the motor assembly L/D. 4) Undo the screw fixing the deck and the main frame, and separate the deck assembly. Check both the hole (A) of gear cam and the hole (A') of chassis correspond (Fig. C-1). 5) Check the mode S/W on the main P.C. board locates at a proper position as in (B) of the Fig. (C-1). 6) Connect the deck to the main P.C. board and perform all types of test.		

CHECK DIAGRAM

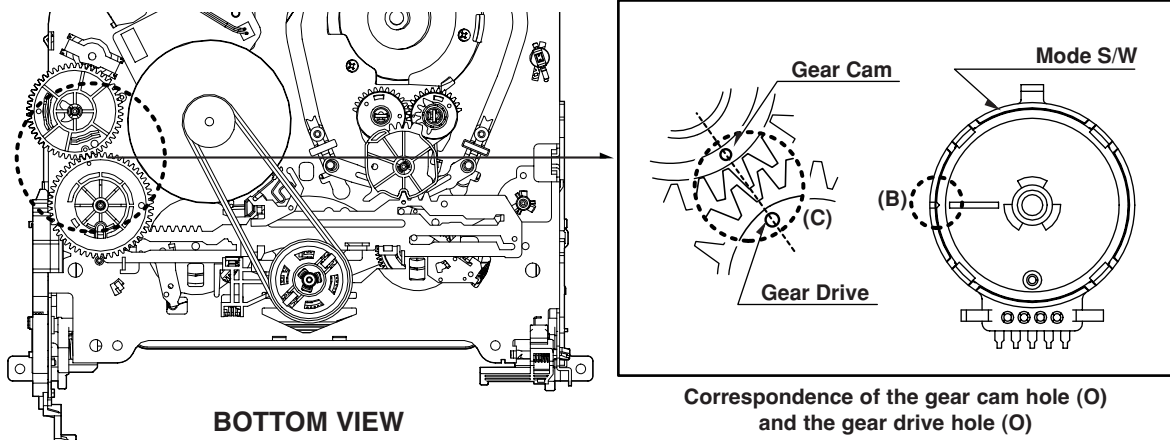

Fig. C-1

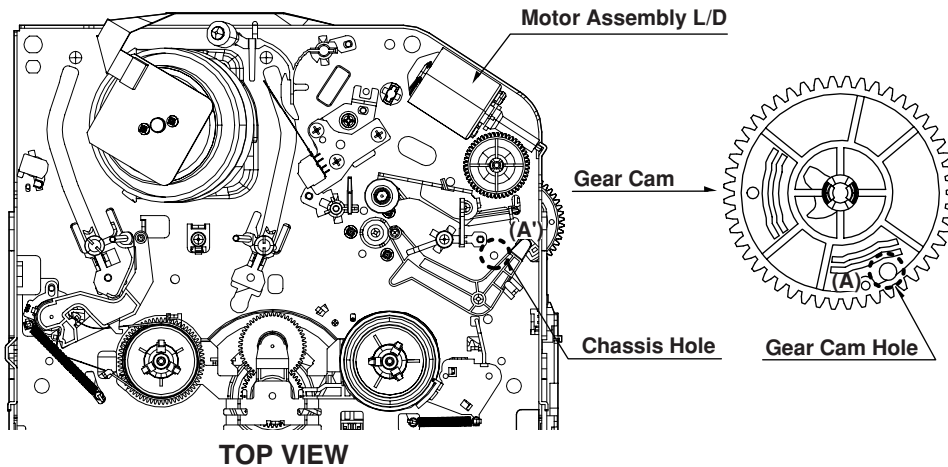

Fig. C-2

DECK MECHANISM ADJUSTMENT

2. Previous Preparation for Deck Adjustment

(Preparation to load the VCR (VCP) with cassette tape not inserted)

- 1) Take the power cord from the consent.
- 2) Separate the top cover and the plate assembly top.
- 3) Insert the power cord into again.
- 4) Turn the VCR (VCP) on and load the cassette while pushing the lever stopper of the holder assembly CST backward. In this case, clog both holes on the housing rail part of chassis to prevent detection of the end sensor.

If doing so, proceeding to the stop mode is done. In this status, input signals of all modes can be received. However, operation of the Rewind and the Review is impossible since the take-up reel remains at stop status and so cannot detect the reel pulse (however, possible for several seconds).

3. Torque Measuring

Purpose of Measuring : To measure and check the reel torque on the take-up part and the supply part that performs basic operation of the VCR (VCP) for smoothly forwarding the tape.
Measure and check followings when the tape is not smoothly wound or the tape velocity is abnormally proceeded:

Fixtures and tools used	VCR (VCP) status	Measuring method
<ul style="list-style-type: none"> • Torque Gauge (600 g.cm ATG) • Torque Gauge Adaptor • Cassette Torque Meter SRK-VHT-303 	<ul style="list-style-type: none"> • Play (FF) or Review (REW) Mode 	<ul style="list-style-type: none"> • Try to operate the VCR (VCP) per mode with the tape not inserted (See '2. Prior Preparation for Deck Adjustment). • Measure after adhering and fixing the torque gauge adaptor to the torque gauge (Fig. C-3-1) • Read scale of the supply or take-up part of the cassette torque meter (Fig. C-3-2).

Item	Mode	Instruments	Reel Measured	Measuring Value
Fast forward Torque	Fast Forward	Torque Gauge	Take-Up Reel	More than 400g°cm
Rewind Torque	Rewind	Torque Gauge	Supply Reel	More than 400g°cm
Play Take-Up Torque	Play	VHT-303	Take-Up Reel	40~100g°cm
Review Torque	Review	VHT-303	Supply Reel	120~210g°cm

NOTE

Adhere the torque gauge adaptor to the torque gauge for measuring the value.

• Torque Gauge (600g.cm ATG)

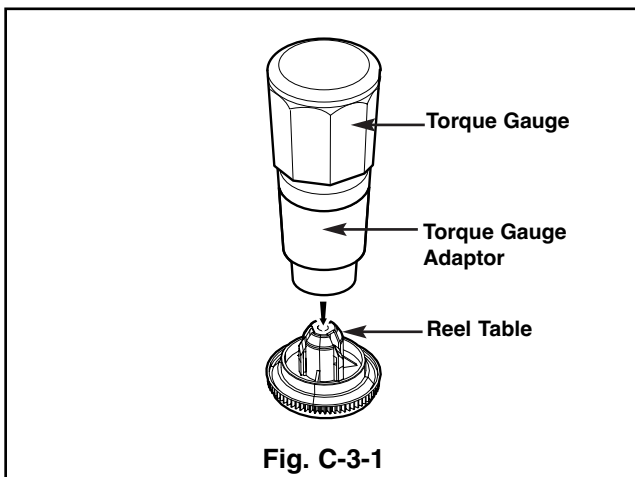

• Cassette Torque Meter (SRK-VHT-303)

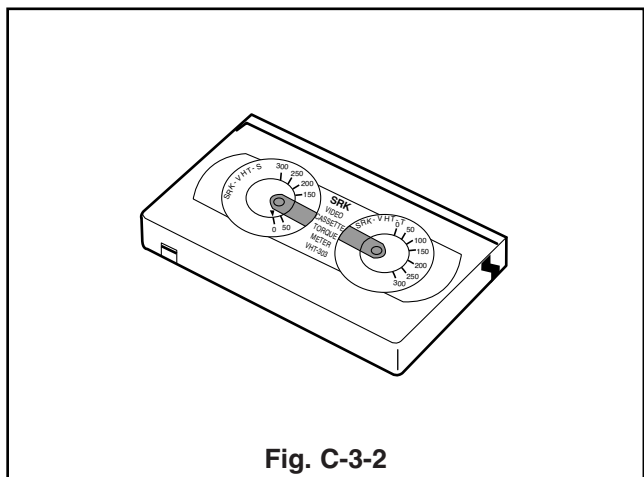

DECK MECHANISM ADJUSTMENT

4. Guide Roller Height Adjustment

Purpose of adjustment : To ensure that the bottom surface of the tape can travel along with the tape lead line of the lower drum by constantly adjusting and maintaining the height of the tape.

4-1. Prior Adjustment

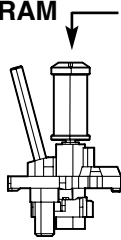
Fixtures and tools used	VCR (VCP) status	Adjustment position
<ul style="list-style-type: none"> • Post Height Adjusting Driver 	<ul style="list-style-type: none"> • Play or Review Mode 	<ul style="list-style-type: none"> • The guide roller height adjusting screw on the supply guide roller and the take-up guide roller
<p>Adjustment Procedure</p> <ol style="list-style-type: none"> 1) Travel the tape and check the bottom surface of the tape travels along with the guide line of the lower drum. 2) If the tape travels toward the lower part of guide line on the lower drum, turn the guide roller height adjusting screw to the left 3) If it travels to the upper part, turn it to the right. 4) Adjust the height of the guide roller to ensure that the tape is guided on the guide line of the lower drum at the inlet/outlet of the drum. (Fig. C-4-1) 		<p>ADJUSTMENT DIAGRAM</p>  <p>Fig. C-4-1</p>

4-2. Fine Adjustment

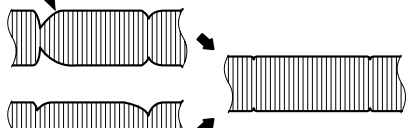
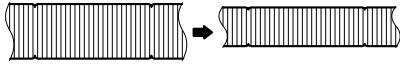
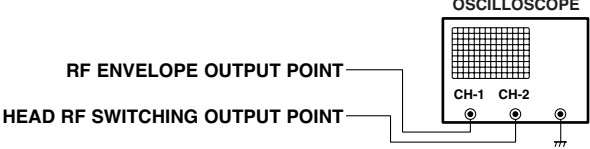
Fixtures and tools used	Measuring tools and connection position	VCR (VCP) status	Adjustment position
<ul style="list-style-type: none"> • Oscilloscope • Standard test tape • Post height adjusting driver 	<ul style="list-style-type: none"> • CH-1: PB RF Envelope • CH-2: NTSC : SW 30Hz PAL : SW 25Hz • Head switching output point • RF Envelope output point 	<ul style="list-style-type: none"> • Play the standard test tape. 	<ul style="list-style-type: none"> • Guide roller height adjusting screw
<ol style="list-style-type: none"> 1) Play the standard test tape after connecting the probe of oscilloscope to the RF envelope output point and the head switching output point. 2) Tracking control (playback) : Locate it at the center (Set the RF output to the maximum value via the tracking control when such adjustment is completed after the drum assembly is replaced.) 3) Height adjusting screw: Flatten the RF waveform. (Fig. C-4-2) 4) Move the tracking control (playback) to the right/left. (Fig. C-4-3) 5) Check the start and the end of the RF output reduction width are constant. 		<p>Waveform</p> <p>P2 POST ADJUSTMENT</p>  <p>P3 POST ADJUSTMENT</p>  <p>Flatten the waveform by lightly turning the guide roller height adjustment screw.</p> <p>When the tracking control locates at the center. When turning the tracking control to both sides.</p> <p>Fig. C-4-2</p>	
<p>CAUTIONS</p> <p>There must exist no crumpling and folding of the tape due to excess adjustment or insufficient adjustment.</p>		<p>Connection Diagram</p> 	

DECK MECHANISM ADJUSTMENT

5. Audio/Control (A/C) Head Adjustment

Purpose of adjustment : To ensure that audio and control signals can be recorded and played according to the contract tract by constantly maintaining distance between tape and head, and tape tension between the P3 post and the P4 post.

5-1. Prior Adjustment (performed only when no audio output appears in play of the standard test tape)

Fixtures and tools used	VCR (VCP) status	Adjustment position
<ul style="list-style-type: none"> • Blank Tape (Empty Tape) • Driver (+) Type $\phi 5$ 	<ul style="list-style-type: none"> • Play the blank tape (empty tape). 	<ul style="list-style-type: none"> • Tilt adjusting screw (C) • Height adjusting screw (B) • Azimuth adjusting screw (A)

Adjustment Procedure/Adjustment Diagrams

- 1) Basically use the A/C head assembly adjusted as in SPEC.
- 2) Check there is crumpling and folding of the tape around the A/C head. If it is, Turn and adjust the tilt adjusting screw to ensure that the tape corresponds to the bottom guide of the P4, and recheck the tape path after proceeding play for 4-5 seconds.

- 3) Where the tape bottom is not equal to Fig. C-5-3, Adjust the height by using the height adjusting screw (B) and then readjust it by using the tilt adjusting screw (C).

CAUTIONS

Always check the height of the A/C head since most ideal height of A/C head can be obtained when the bottom part of the tape is away 0.2 ~ 0.25mm from the bottom part of the A/C head.

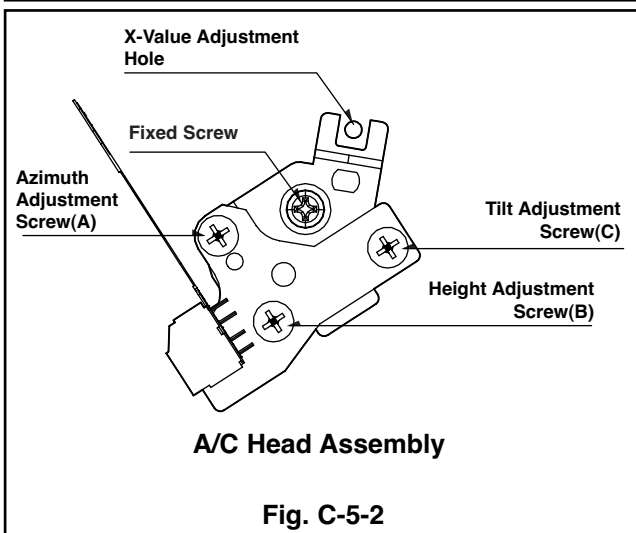
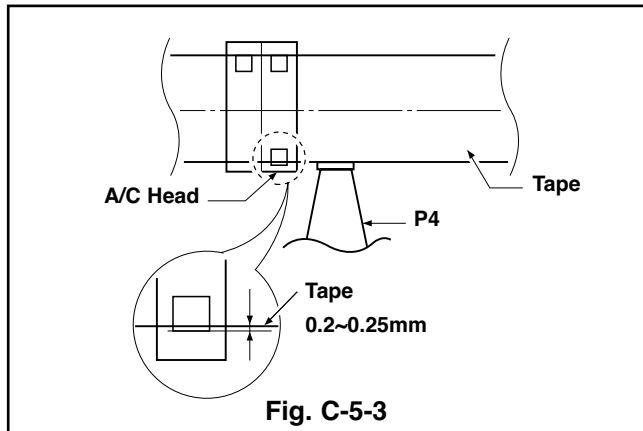
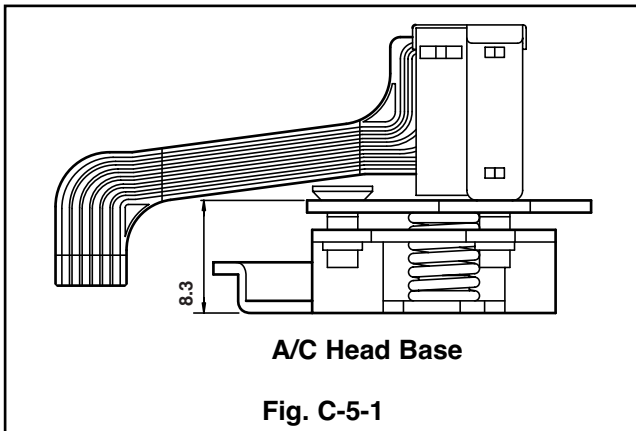

DECK MECHANISM ADJUSTMENT

5-2. Tape Path Check between Pinch Roller and Take up Guide (Check in the Rev Mode)

- 1) Check the tape pass status between the pinch roller and the take-up guide. (Check there is crumpling of the tape pass and folding of the take-up guide.)
 - (1) When holding of the take-up guide bottom occurs
Turn the tilt adjusting screw (C) clockwise and travel it stably to ensure there is no crumbling or folding of the tape.
 - (2) When holding of the take-up guide top occurs
Turn the tilt adjusting screw (C) anti-clockwise and

travel it stably to ensure there is no crumbling or folding of the tape.

- 2) Check there is folding of the tape at the bottom or top of the take-up guide in cutting-off the REV mode

CAUTIONS

If the RF waveform is changed after adjusting the A/C head, perform fine adjustment to ensure the RF waveform is flattened.

5-3. Fine Adjustment (Azimuth Adjustment)

Fixtures and tools used	Connection position	VCR (VCP) status	Adjustment position
<ul style="list-style-type: none"> • Oscilloscope • Standard test tape (only for SP) • Driver (+) Type Ø 4 	<ul style="list-style-type: none"> • Audio Output Jack 	<ul style="list-style-type: none"> • Play the standard test • Tape, 1KHz, 7KHz. 	<ul style="list-style-type: none"> • Azimuth Adjusting Screw (A) • Height Adjusting Screw (B)
Adjustment Procedure 1) Connect the probe of Oscilloscope to the audio output jack. 2) Ensure that Audio 1KHz, 7KHz output is flattened at the maximization point by adjusting the Azimuth adjusting screw (A).			

Fig. C-5-4

6. X-distance Adjustment

Purpose of adjustment : To maintain compatibility with other VCR (VCP).			
Fixtures and tools used	Connection position	VCR (VCP) status	Adjustment position
<ul style="list-style-type: none"> • Oscilloscope • Standard test tape (only for SP) • Driver (+) Type Ø 4 	<ul style="list-style-type: none"> • CH-1: PB RF Envelope • CH-2: NTSC ; SW 30Hz PAL:SW 25Hz • Head switching output point • RF Envelope output point 	<ul style="list-style-type: none"> • Play the standard test tape. 	
Adjustment Procedure 1) After releasing the auto tracking, lightly turn the fixing screw. Turn the (+) type driver (Ø 3 ~ Ø 4) on the X-distance adjusting hole to the right or left. Adjust the RF envelope level to the maximum point and then fix the fixing screws. 2) For the 31mm head, adjust it with the SP tape recorded in the width of 31mm since the head travels on the tape track only for SP with the width of 58mm.		Connection Diagram 	

Fig. C-6

DECK MECHANISM ADJUSTMENT

7. Adjustment after Drum Assembly (Video Heads)

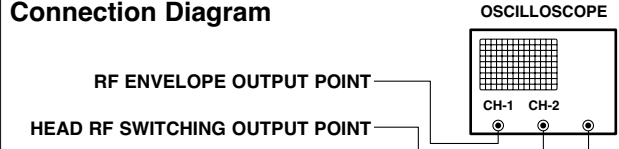
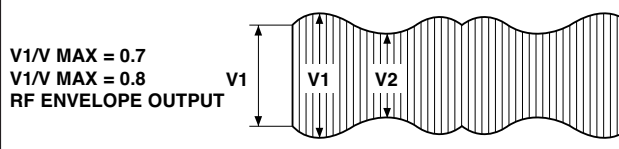
Purpose of adjustment : To adjust and stabilize the height change, X-distance change, etc depending on the guide roller after assembling the drum.			
Fixtures and tools used	Connection position	VCR (VCP) status	Adjustment position
<ul style="list-style-type: none"> • Oscilloscope • Standard test tape (only for SP) • Post Height Adjusting Driver • Driver (+) Type Ø 5 	<ul style="list-style-type: none"> • CH-1: PB RF Envelope • CH-2: NTSC : SW 30Hz PAL:SW 25Hz • Head switching output point • RF Envelope output point 	<ul style="list-style-type: none"> • Play the blank tape. • Play the standard test tape. 	<ul style="list-style-type: none"> • Fine adjustment of guide roller • Switching Point • Tracking Preset • X-distance
Checking/Adjustment Procedure <ol style="list-style-type: none"> 1) Play the blank tape (empty tape) and check whether the guide roller crumbles or wrinkles the tape and adjust it if necessary. 2) Check that the RF envelope output waveform is flat, and adjust the height of the guide roller while playing the standard test tape. 3) Adjust the switching point. 4) Check the RF envelope output is the maximum when the tracking control locates at the center. If not maximum, set up to ensure that RF envelope output becomes the maximum by turning the (+) type driver (Ø 3 ~ Ø 4) on the base A/C groove. 		Connection Diagram  Waveform 	

8. Check of Traveling Device after Deck Assembly

8-1. Audio, RF Normalization Time (Locking Time) Check in Play after CUE or REV

Fixtures and tools used	Measuring standard	Connection position	VCR (VCP) status
<ul style="list-style-type: none"> • Oscilloscope • 6H 3KHz Color Bar Standard Test tape • Stop Watch 	<ul style="list-style-type: none"> • RF Locking Time: Within 5 seconds • Audio Locking Time : Within 10 seconds 	<ul style="list-style-type: none"> • CH-1: PB RF Envelope • CH-2: Audio output • RF Envelope output point • Audio output jack 	<ul style="list-style-type: none"> • Play the 6H 3KHz Color Bar Standard Test tape.
Checking Procedure <ol style="list-style-type: none"> 1) Check that locking time of the RF and Audio waveform is fallen within the measuring standard in conversion of the play mode from the CUE or the REV mode. 		<ol style="list-style-type: none"> 2) Readjust the paragraph 5 and 6 if it deviates from the standard. 	

8-2. Check of Tape Curl and Jam Status

Fixtures and tools used	Fixtures and tools used	Fixtures and tools used
<ul style="list-style-type: none"> • T-160 Tape • T-120 Tape 	<ul style="list-style-type: none"> • There must be no jam or curl at the first, middle and end position of tape. 	<ul style="list-style-type: none"> • Travel the tape at the position of its first and end.
Checking Procedure <ol style="list-style-type: none"> 1) Check there is no abnormality of every traveling post status. 2) There must be no abnormal operation of the counter in 		<ol style="list-style-type: none"> occurrence of folding of the bottom tape. There must be not abnormality of audio signal in damage of the top tape. 3) If there is abnormality, readjust the adjustment paragraph 4 and 5.

PROTECTION, MAINTENANCE AND CHECK OF VIDEO FUNCTION

1. Checking Points prior to Repair

Following abnormal phenomena may be repaired by removal of foreign materials and oil supply. Check oiling is required at the checking set or cleaning status is complete. Determine that necessity of checking and repair the set exists after checking the using period of the set together with the user. In this case, followings must be checked:

Phenomena	Checking Points and Cause	Replacement
Color beat	Pollution of Full-Erase Head	○
S/N, Color Faded	Pollution of Video Head	○
Horizontal, Vertical Jitte	Pollution of Video Head or Tape Transport System	○
Poor Sound, Low Sound	Pollution of Audio/Control Head	○
No tape wound or tape wound loosely. FF or REW impossible, or slow turning	Pollution of Pinch Roller or Belt Capstan Belt	○
Tape loosely wound in REV or Unloading	Deterioration of Clutch Assembly D37 Torque Pollution of Drum and Traveling Device	○ Fig. C-9-3

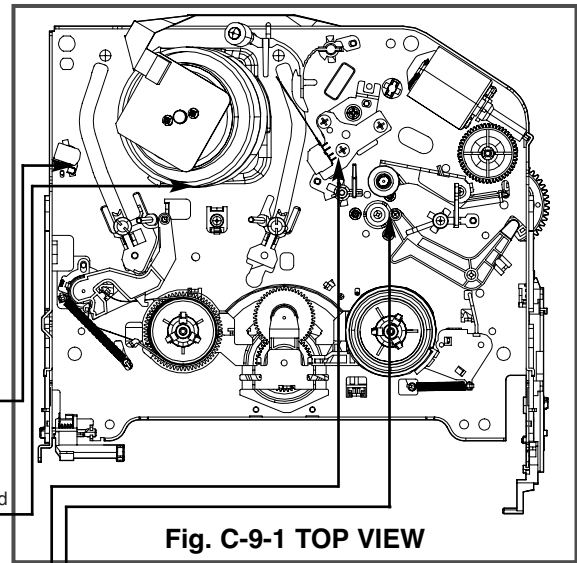

Fig. C-9-1 TOP VIEW

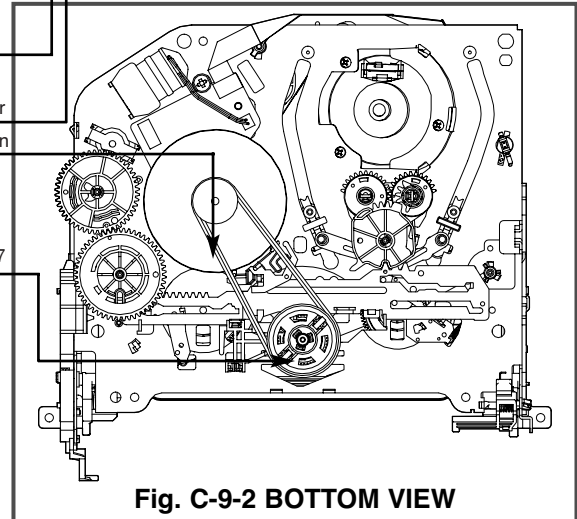

Fig. C-9-2 BOTTOM VIEW

CAUTIONS

If operation of the position with (O) mark is abnormal even after removing cause, replace it with substitute product since it shows damage or wearing.

* No. (1) ~ (12) shows sequence that the tape moves from the supply reel to the take-up reel.)

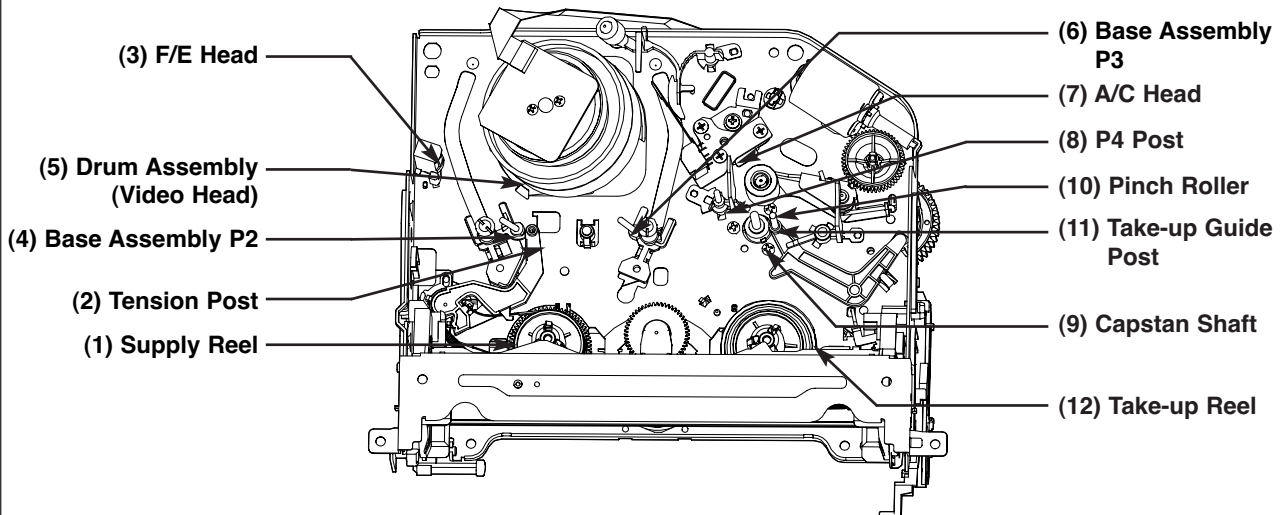

Fig. C-9-3 Tape Transport System

PROTECTION, MAINTENANCE AND CHECK OF VIDEO FUNCTION

2. Essential Check and Repair

Recording density of the video is far higher than the audio. Therefore video parts are very precise so as to allow only error of 1/1000mm or so in order to maintain compatibility with other videos.

If one of these parts is polluted or old, same phenomena will appear as they are damaged.

To maintain clear screen, regular check, replacement of old and damaged parts and oil supply, etc are essential.

3. Regular Check and Repair

Check and repair schedule is not constant since they vary depending on method that the consumer uses video and environment where the video is installed at.

However, for the video used by common household, good screen will be maintained if regular check and repair per 1,000 hour is performed. The following chart shows relationship between using time and checking time:

Table 1

Time Requiring Checking	About 1 year	About 18 months	About 3 years
Average hours used per day	▲	▲	▲
One hour	[Bar chart showing 1 hour of use]		
Two hours	[Bar chart showing 2 hours of use]		
Three hours	[Bar chart showing 3 hours of use]		

4. Tools for Check and Repair

- (1) Grease: Floil G-3114 (KANTO) or equivalent grease (Green)
- (2) Grease: Kanto G-754, PL-433 (Yellow)
- (3) Alcohol (Isopropyl Alcohol)
- (4) Cleaning Patch (cloth)

5. Maintenance Process

5-1) Removal of Foreign Material

- (1) Removal of foreign material from video head (Fig. C-9-4)
Firstly try to use a cleaning tape.

Use a cleaning patch if foreign materials are not removed with the cleaning tape due to severe dirty of the head. Soak the cleaning patch in alcohol and put it to the head tip. Smoothly turn the drum (turning cylinder) to the right or left (In this case, the cleaning patch must not be moved vertically).

After completely drying the head, test the traveling status of the tape.

If alcohol (Isopropyl Alcohol) remains at the video head, the tape may be damaged when this solution touches with the head surface.

Never use a cloth bar (commercial sale)

- (2) Wipe the tape transport system and the drive system with the cleaning patch soaked in alcohol (Isopropyl Alcohol) when removing foreign materials from them.
 - 1) The part touched with the traveling tape is called as tape transport system. The drive system consists of parts to travel the tape.
 - 2) Care must be exercised so that unreasonable force to change the pattern will be applied to the tape transport system during removal of foreign materials.

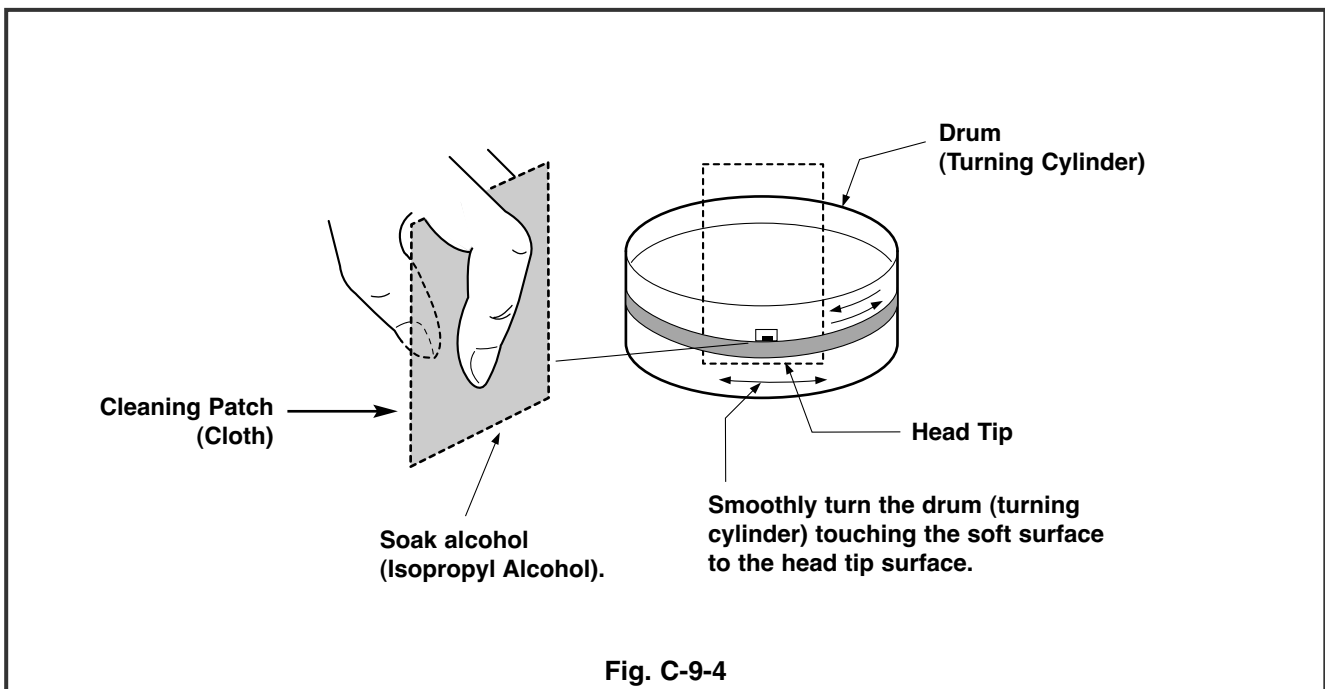

Fig. C-9-4

PROTECTION, MAINTENANCE AND CHECK OF VIDEO FUNCTION

5-2) Grease Applications

(1) Grease Application Method

Apply grease by using a cloth swab or brush. Care must be exercised so that excess quantity should not be used. If the excessive quantity is applied, wipe it with the gauze soaked in alcohol (Isopropyl Alcohol).

NOTE: POSITION OF GREASE APPLICATION

- | | |
|--|----------------------------------|
| (1) Inner Side Surface and Top Surface of Loading Path | (4) Gear Wheel Shaft |
| (2) Stable Adhesion Part of Base P2, P3 | (5) Reel S. T. Shaft |
| (3) Arm Pinch Shaft | (1) (2) (3) (4): KG-684G (Green) |
| | (5): PL-433 (Yellow) |

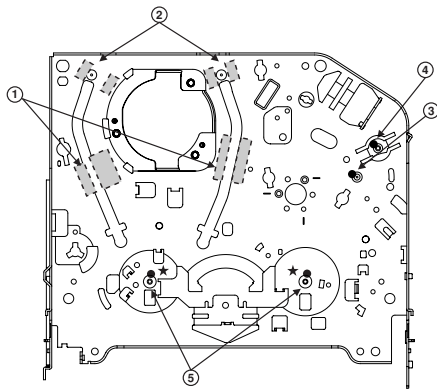

Chassis (TOP)

Gear Part

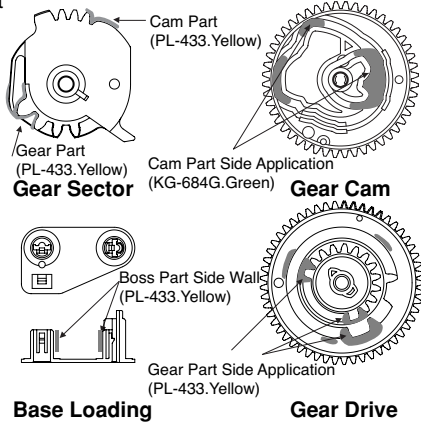

(2) Regular Grease Application

Apply grease to the designated application position every 500 hour.

- | | |
|--|--|
| (1) Inner Side Surface and Top Surface of Loading Path | (6) Guide Part on the Plate Slider Side Wall (Left) |
| (2) Stable Adhesion Part of Base P2, P3 Coil | (7) Guide Part on the Plate Slider Side Wall (Right) |
| (3) Gear Cam Shaft | (1) (2) (3) (4) (5) (6) (7): KG-684G (Green) |
| (4) Gear Drive Shaft | |
| (5) Clutch Shaft Groove | |

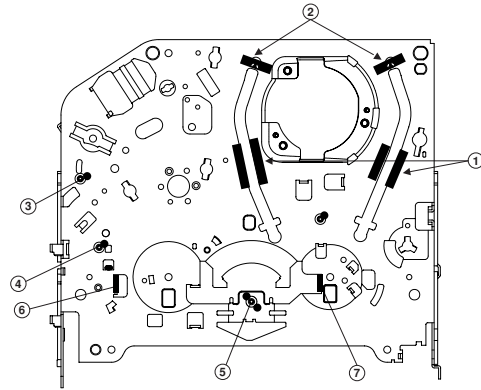

Chassis (Bottom)

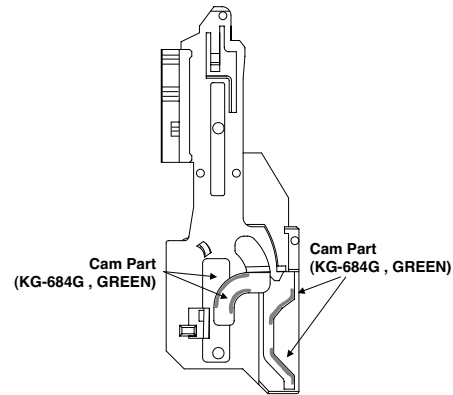

Gear Rack F/L

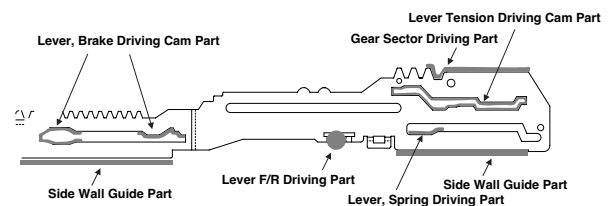
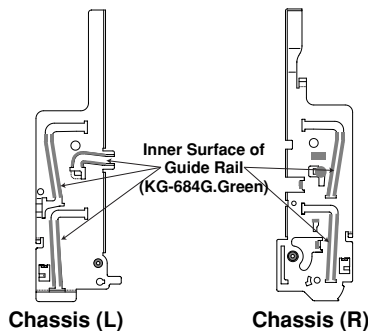
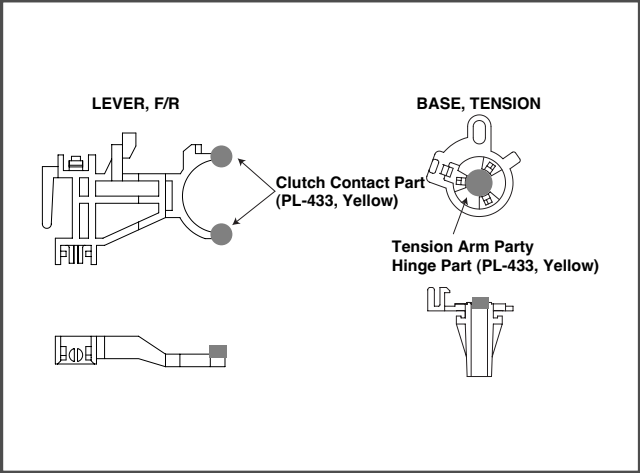

Plate Slider

PROTECTION, MAINTENANCE AND CHECK OF VIDEO FUNCTION

Lever, F/R, Base, Tension



GEAR AY, P2 & P3

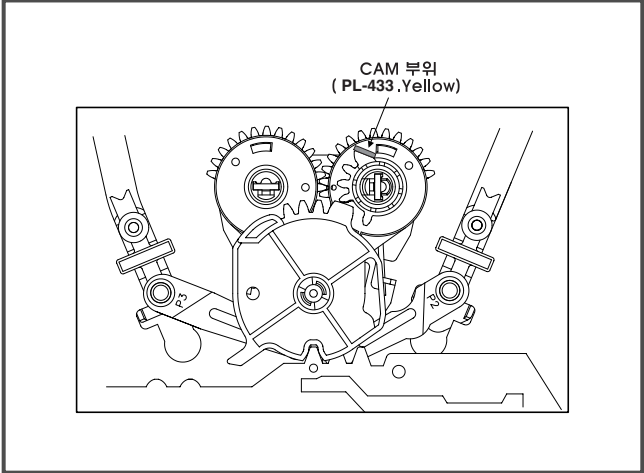

MECHANISM TROUBLESHOOTING GUIDE

1. Deck Mechanism

A.

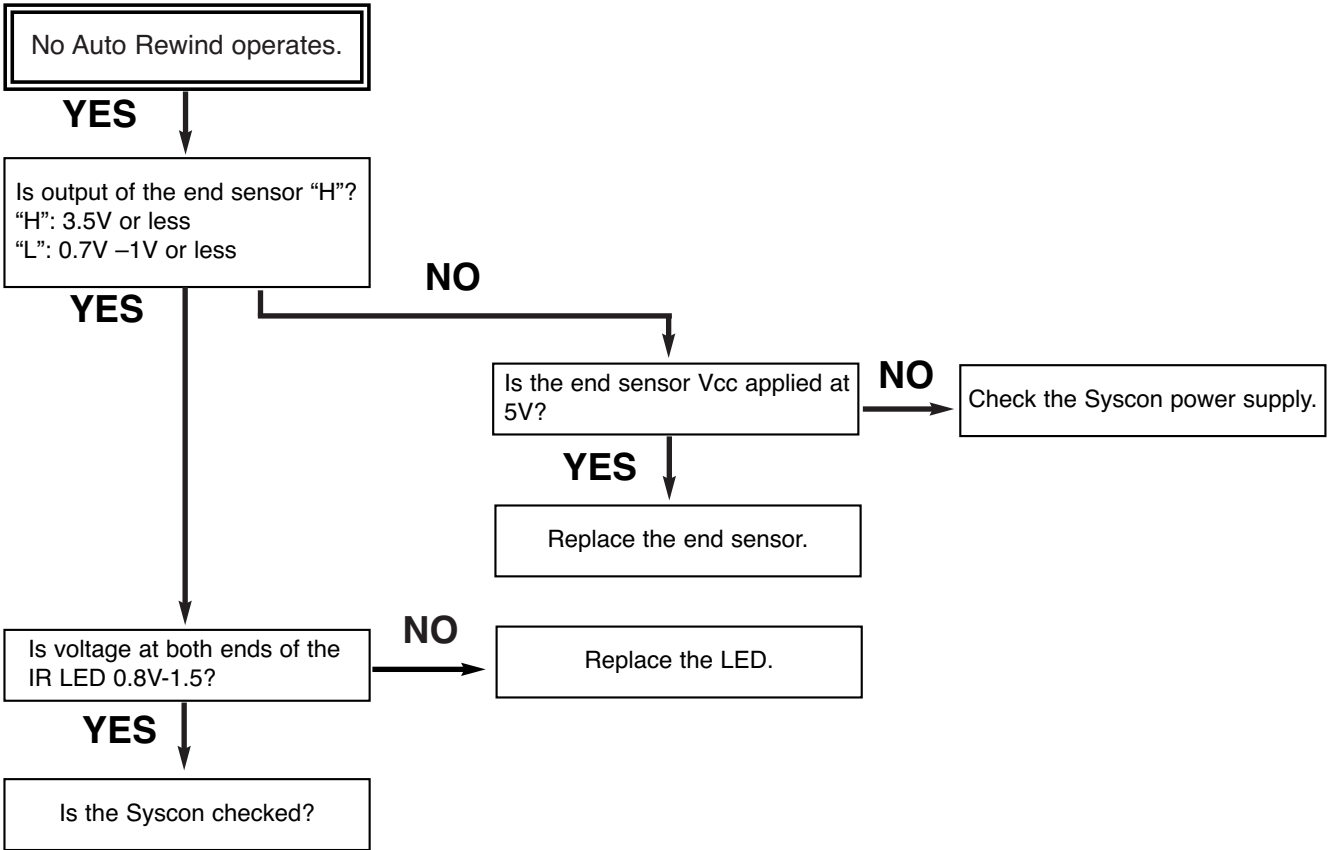

B.

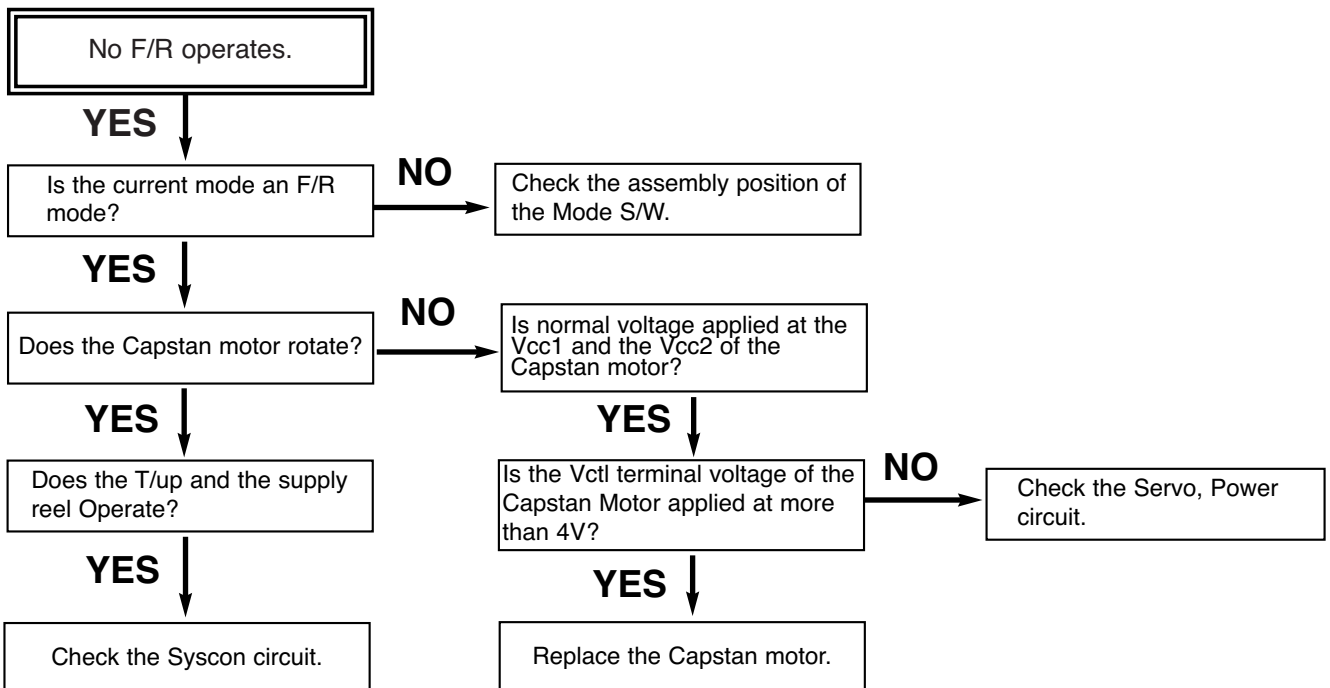

MECHANISM TROUBLESHOOTING GUIDE

C.

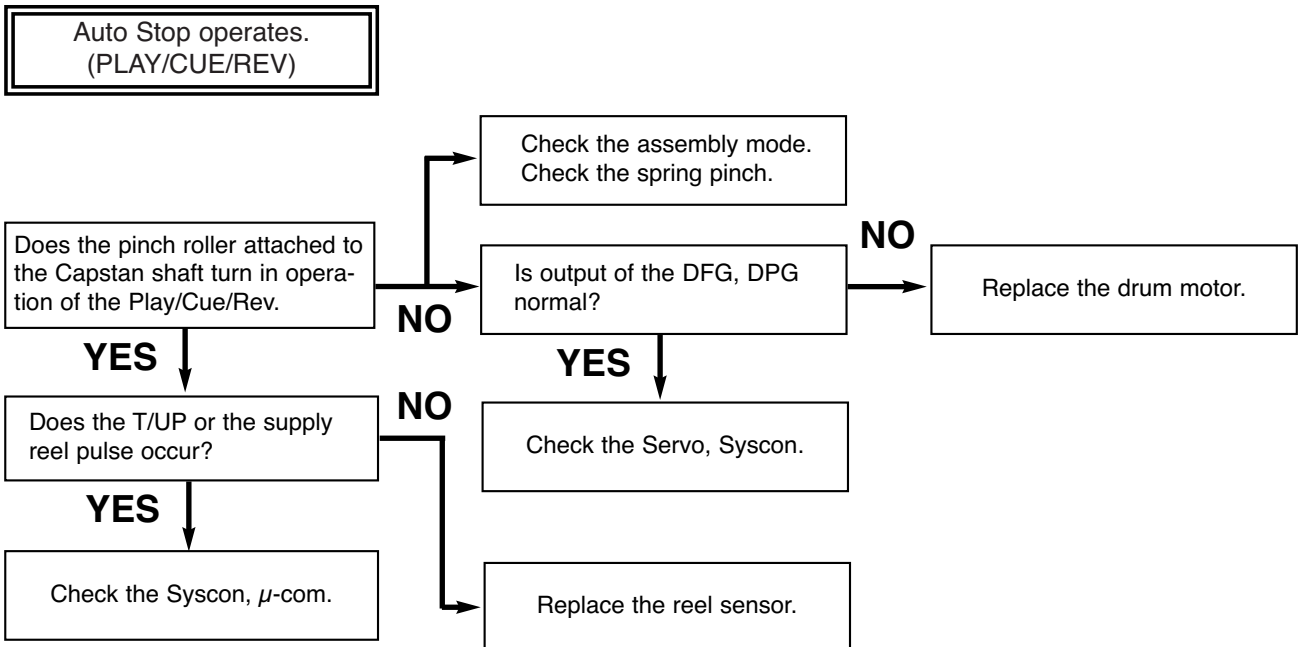

D.

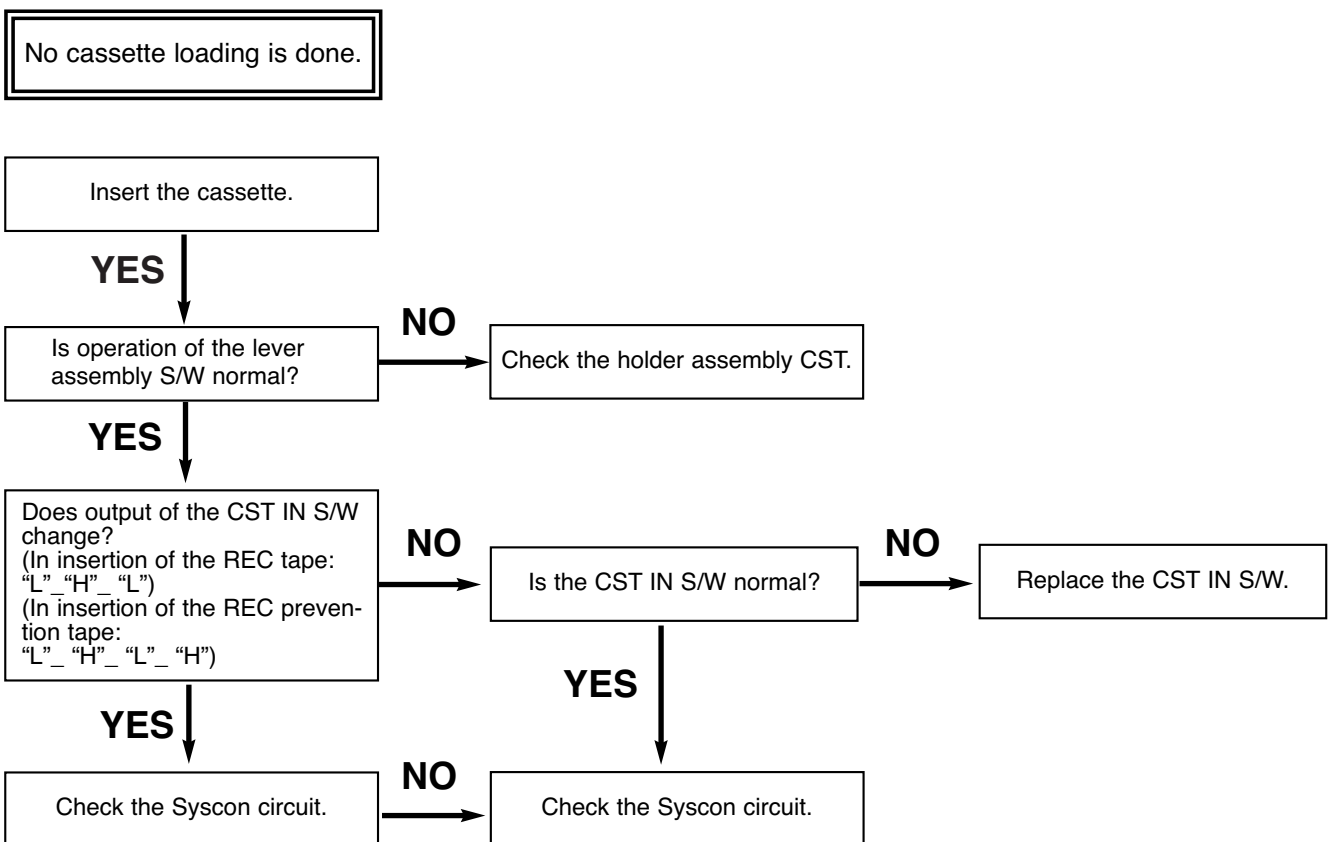

MECHANISM TROUBLESHOOTING GUIDE

E.

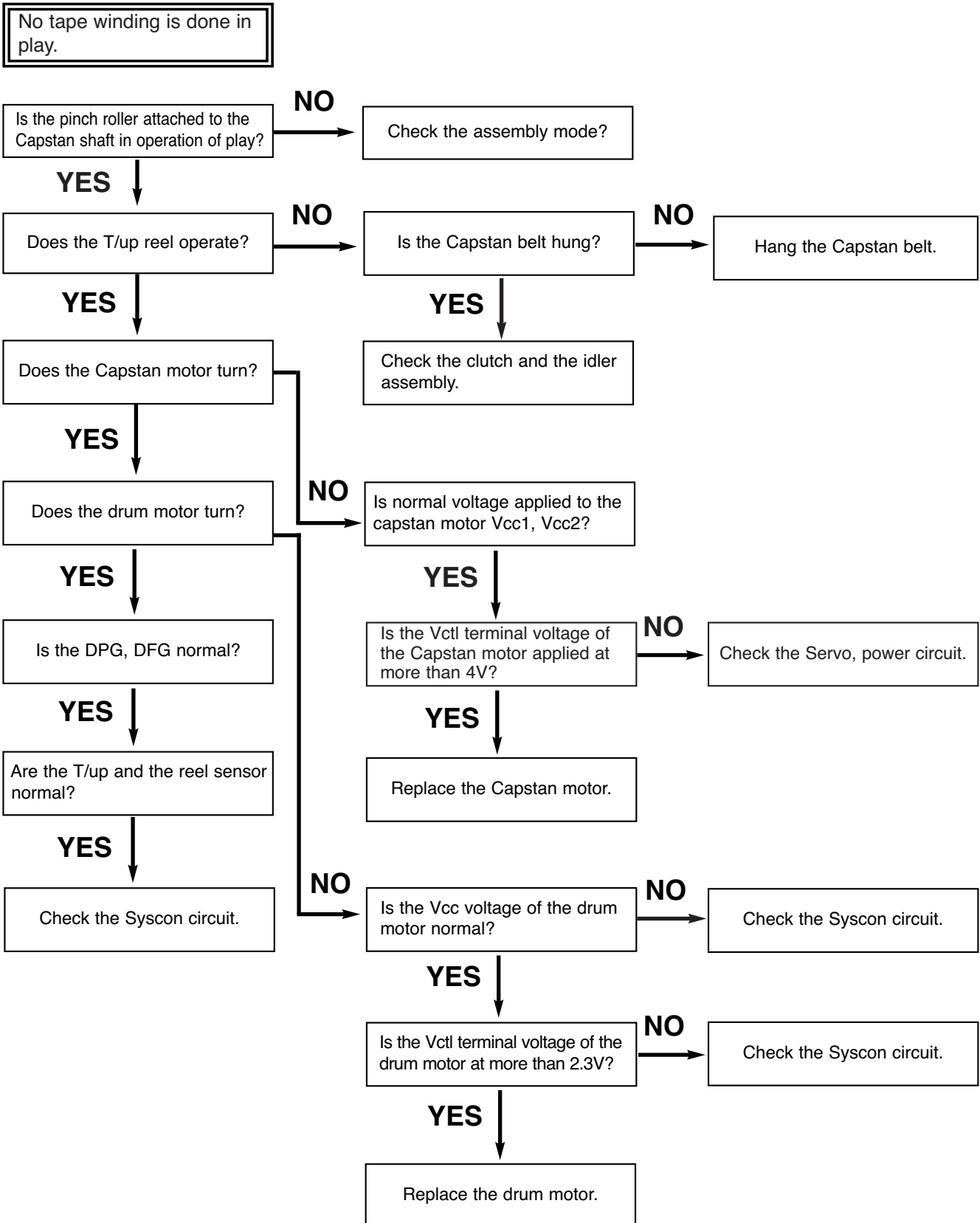

MECHANISM TROUBLESHOOTING GUIDE

2. Front Loading Mechanism

A.

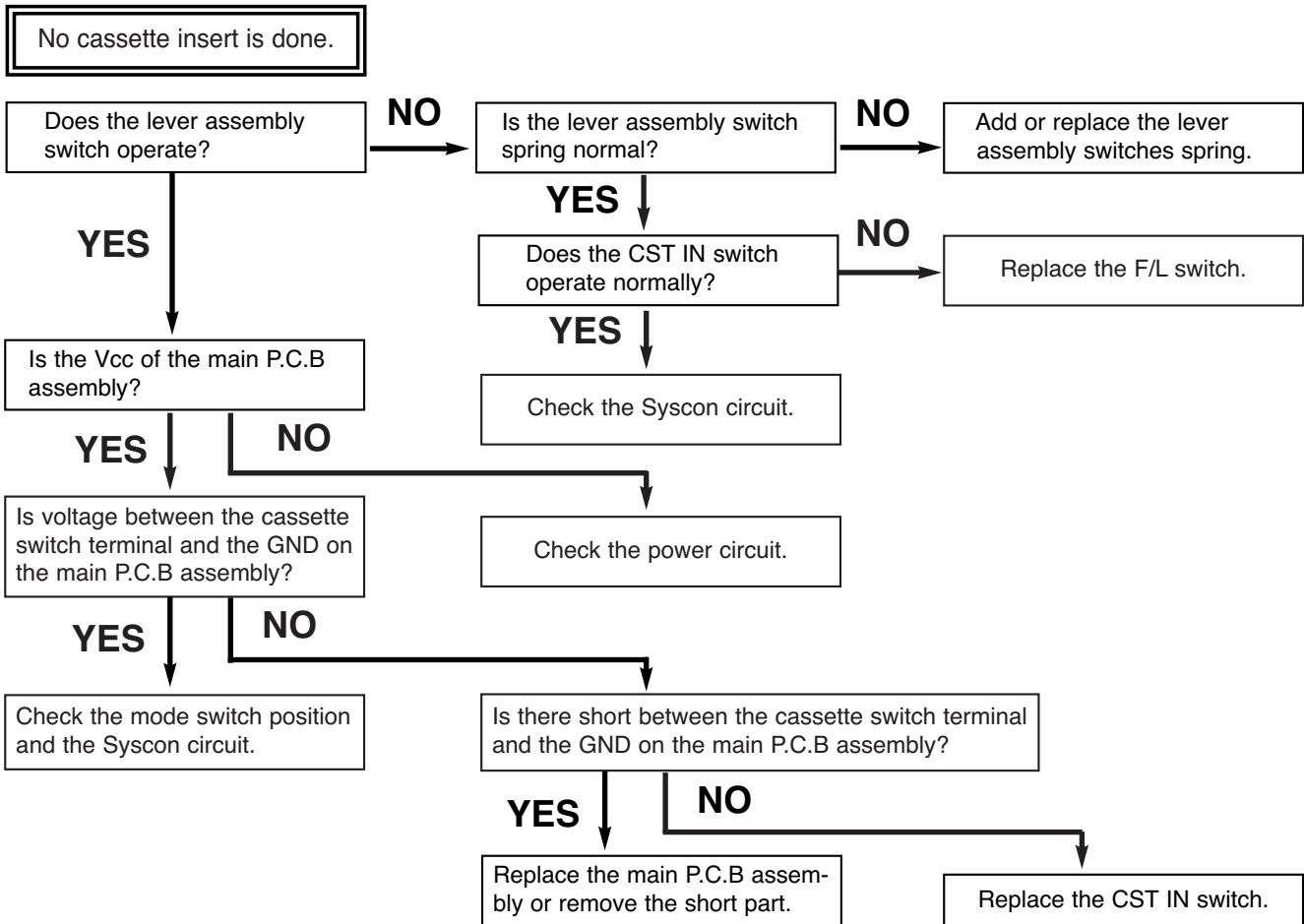

B.

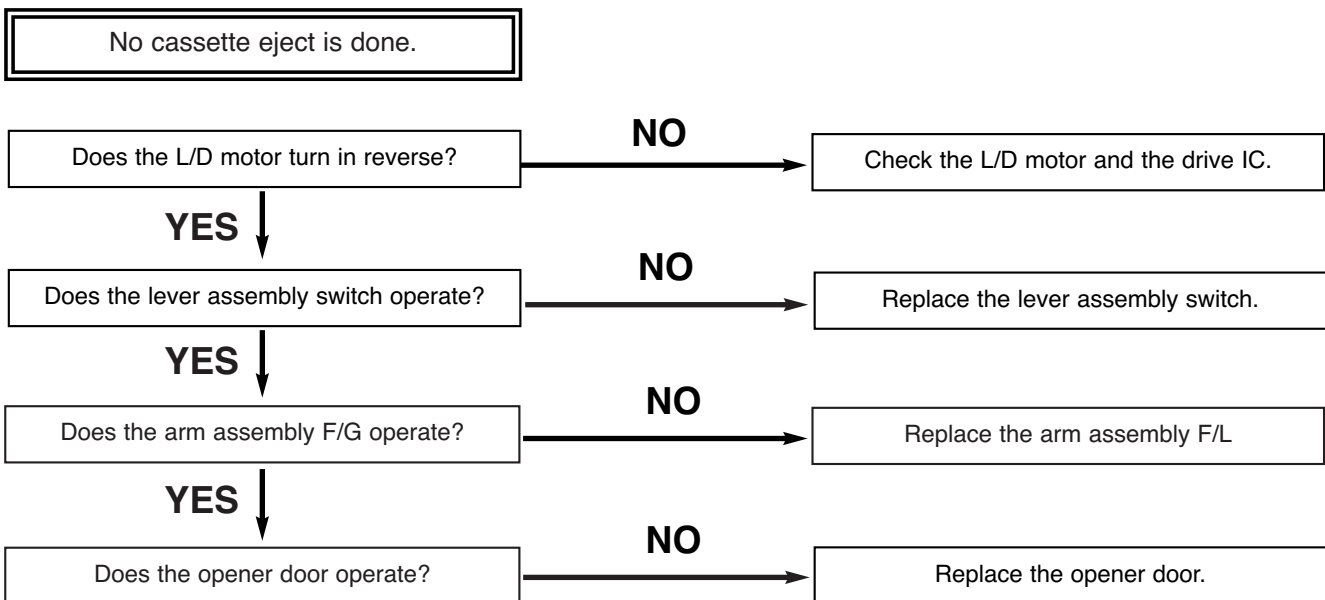

MECHANISM TROUBLESHOOTING GUIDE

C.

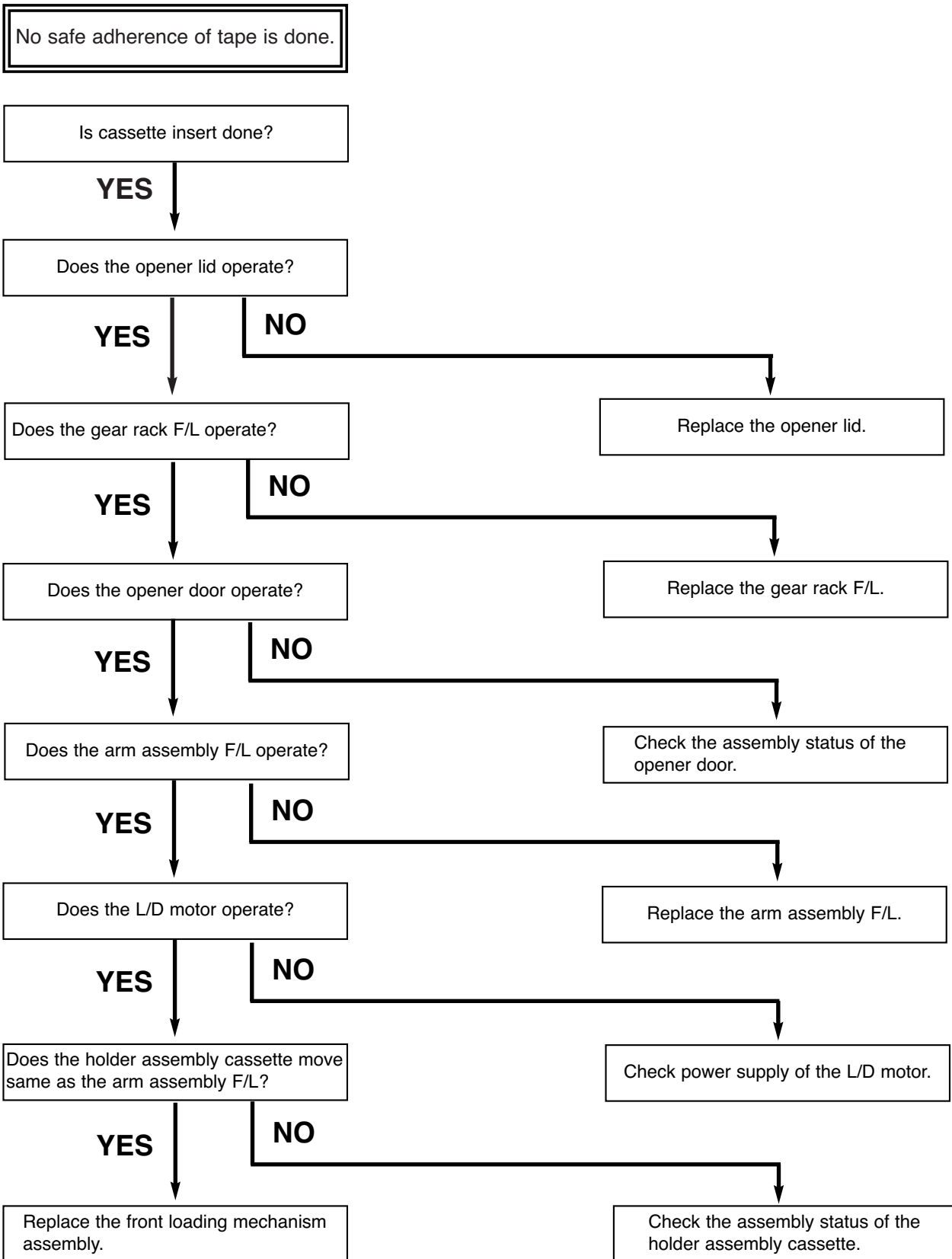

EXPLODED VIEWS

1. Front Loading Mechanism Section

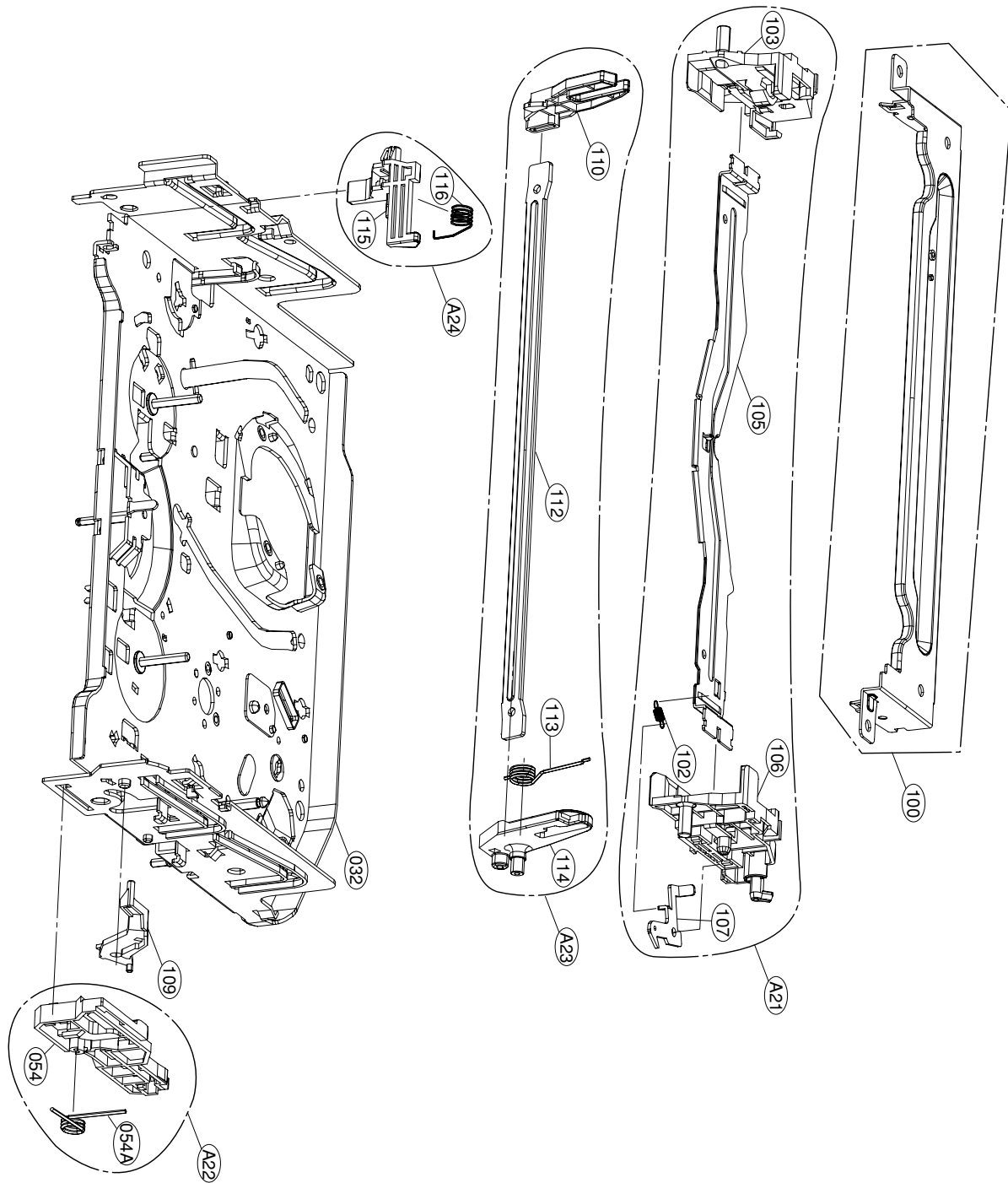

EXPLODED VIEWS

2. Moving Mechanism Section (1)

★ OPTIONAL PART

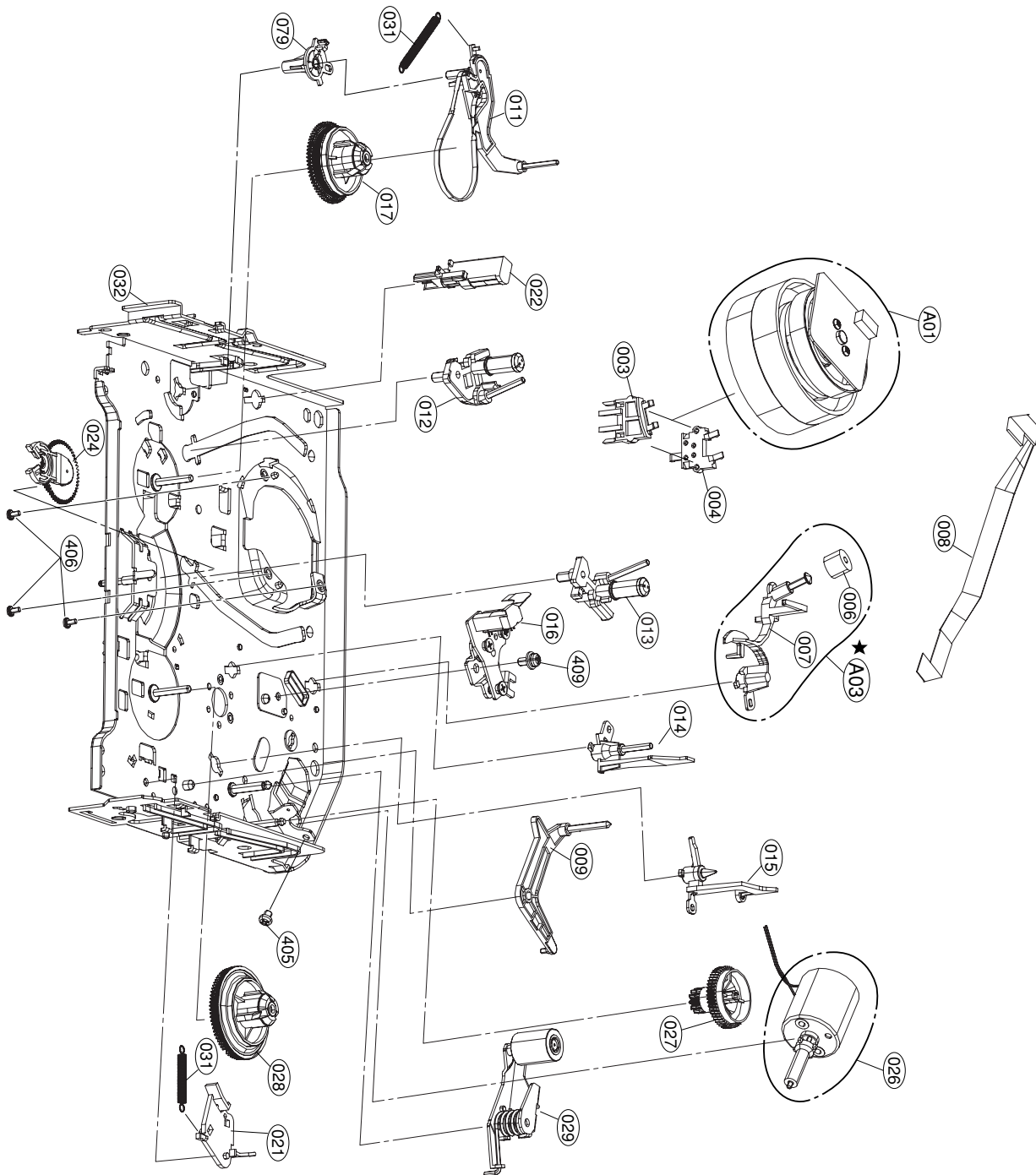

MECHANICAL & ACCESSORIES PARTS LIST**SET & PACKAGING PARTS (FOR PAGES 2-2 TO 2-3)**

	9965 000 26494	FLEX CABLE 15PINS 7CM FOR CONN PN303 ON VDR (DIGITAL) BOARD	022	9965 000 25637	HEAD(CIRC), ST FE HEAD FOR D37
			023	9965 000 25638	BASE, LOADING OTHER
	9965 000 26493	FLEX CABLE 30PINS 11CM FOR CONN PN304 ON VDR (DIGITAL) BOARD	024	9965 000 25639	ARM ASSEMBLY, IDLER(H)
			026	9965 000 25817	MOTOR ASSEMBLY
A00	9965 000 25784	VCR DECK MECH ASSY	028	9965 000 25642	REEL, T OTHER
A43	9965 000 25778	FRONT PANEL ASSEMBLY /00/14	029	9965 000 25643	ARM ASSEMBLY, PINCH
A43	9965 000 25960	FRONT PANEL ASSEMBLY /02	031	9965 000 25644	SPRING, COIL TENSION
A43	9965 000 25963	FRONT PANEL ASSEMBLY /05	051	9965 000 19315	CAPSTAN
A60	9965 000 25789	RL-02A LOADER (DVDR) MODULE	052	9965 000 25645	MOTOR, CAPSTAN F2QVB66 SANKYO FO
261A	9965 000 25780	RUBBER FOOT	052 *	9965 000 25818	CAPSTAIN, MOTOR
264	9965 000 25779	FAN, DC 60X60X15MM	052 *	9965 000 25819	CAPSTAIN, MOTOR
265	9965 000 25546	HOLDER, POWER CORD	052A	9965 000 25660	SUPPORTER, CAPSTAN OTHER
274	9965 000 26264	PLATE, AV GROUND	055	9965 000 25646	GEAR, DRIVE OTHER
283	9965 000 25773	VCR DOOR	056	9965 000 25647	GEAR, CAM OTHER
284	4822 492 42785	SPRING DOOR	058	9965 000 25648	BRAKE ASSEMBLY, CAPSTAN
285	9965 000 25774	DVD DOOR	060	9965 000 25649	LEVER, F/R OTHER
286	9965 000 25776	SPRING, DVD DOOR	061	9965 000 25650	CLUTCH ASSEMBLY, D37(M)
287	9965 000 25777	PLATE, COVER DV-IN	064	9965 000 25651	GEAR, SECTOR OTHER
288	9965 000 26256	DOOR, FLAP	076	9965 000 25652	LEVER, SPRING OTHER
289	9965 000 26257	WINDOW, DECO DOOR	077	9965 000 25653	PLATE, SLIDER OTHER
290	9965 000 26259	FLEX CABLE 40PIN 15CM	078	9965 000 25654	LEVER, TENSION OTHER
300	9965 000 25771	△ POWER CORD /00/02/14	079	9965 000 25655	BASE, TENSION OTHER
300	9965 000 26265	△ POWER CORD /05	100	9965 000 25657	PLATE ASSEMBLY, TOP
806	9965 000 25781	RF CABLE	109	9965 000 25658	OPENER, DOOR OTHER
811	9965 000 25782	VIDEO CABLE YEL	405	9965 000 25659	SCREW, PAN HEAD M3.0 L4.0
812	9965 000 25783	AUDIO CABLE WHITE/RED	406	4822 502 21655	SCREW, PAN HEAD D3.0 L6.0
821	9965 000 26260	SCART CABLE 21PIN	409	9965 000 19341	SCREW D2.6 L5.0
900	9965 000 25772	REMOTE CONTROL RC-DVDR630VR	410	9965 000 19342	SCREW, TAP TITE D2.6 L6.8
			517	9965 000 13164	WASHER STOPPER
			518	9965 000 13163	WASHER STOPPER

VCR MECHANISM PARTS (FOR PAGES 4-28 TO 4-30)

A01	9965 000 25820	DRUM, HEAD ASSEMBLY
A03	9965 000 25618	ARM ASSEMBLY, CLEANER
A11	9965 000 25619	GEAR ASSEMBLY, P3
A12	9965 000 25620	GEAR ASSEMBLY, P2
A21	9965 000 25621	HOLDER ASSEMBLY, CST
A22	9965 000 25622	GEAR ASSEMBLY, RACK F/L
A23	9965 000 25623	ARM ASSEMBLY, F/L
A24	9965 000 25624	LEVER ASSEMBLY, SWITCH(C)
003	9965 000 25625	HOLDER, FPCB(6CH)
004	9965 000 25626	CAP, FPCBLD
008	9965 000 25627	CABLE, FLAT 7PIN 17CM
009	9965 000 25628	ARM, T/UP OTHER
011	9965 000 25629	ARM ASSEMBLY, TENSION
012	9965 000 25630	BASE ASSEMBLY, P2
013	9965 000 25631	BASE ASSEMBLY, P3
014	9965 000 25632	BASE ASSEMBLY, P4
015	9965 000 25633	OPENER, LID OTHER
016	9965 000 25634	BASE ASSEMBLY, A/C HEAD (ALPS)
016 *	9965 000 25816	BASE ASSEMBLY
017	9965 000 25635	REEL, S OTHER
021	9965 000 25636	BRAKE ASSEMBLY, T

* ALTERNATIVE PART CODE

Note: Only the parts mentioned in this list are normal service spare parts.

ELECTRICAL PARTS LIST

VCR MAIN BOARD ASSEMBLY

MISCELLANEOUS

323	9965 000 25560	CASE ASSEMBLY	
CS501	9965 000 25563	SWITCH MPU12970MLB0	
ES501	9965 000 25790	HOLDER ASSY, DECK/MECHA END	
ES502	9965 000 25790	HOLDER ASSY, DECK/MECHA END	
F903	9965 000 18627	CFI06B1H101MF SAMHWA TP 2-5K	
F904	9965 000 18627	CFI06B1H101MF SAMHWA TP 2-5K	
F905	9965 000 18627	CFI06B1H101MF SAMHWA TP 2-5K	
F906	9965 000 18627	CFI06B1H101MF SAMHWA TP 2-5K	
JK901	9965 000 25795	DVD/VCR OUT - Y/PR/PB + L/R + CO	
JK903	9965 000 25796	S-VIDEO OUT (REAR)	
MS501	9965 000 25594	SWITCH SSS-51MD-3 5VDC 1MA D3	
MS501 *	9965 000 25595	SWITCH MMS01080ZMBO5VDC 1MA D37	
P3D01	9965 000 25801	FLEX SOCKET 9PIN VERT	
P3D02	9965 000 25802	FLEX SOCKET 6PIN VERT	
P3D03	9965 000 25803	SOCKET GB201-2P-TS-B	
PM601	9965 000 25804	SOCKET, TUC-P12P-B1 12P	
PM602	9965 000 25805	SOCKET, TUC-P05P-B1 5P 2.0MM	
PMC01	9965 000 25806	SOCKET JE612-A2T-12A 12P 2.0M	
PMD01	9965 000 25807	FLEX SOCKET 15PIN VERT	
PMD02	9965 000 25808	FLEX SOCKET 30PIN VERT	
RS501	9965 000 25602	KIT-3001A REEL SENSOR	
RS502	9965 000 25602	KIT-3001A REEL SENSOR	
SC901	9965 000 25603	DOUBLE - SCART DSAM-0341	
SW901	9965 000 25811	SLIDE SWITCH - RGB / COMPONENT	
TU701	9965 000 25812	TUNER UNIT TADM-M901D PAL/MULT	
		/00/05/14	
TU701	9965 000 25811	TUNER UNIT TADM-S101D	/02
X301	9965 000 25609	X'TAL 4.433619MHZ HC-49S	
X501	9965 000 25815	X'TAL RESONATOR 14.31818MHZ	
X502	9965 000 25611	X'TAL 32.768KHZ	
X751	9965 000 18660	49U BUBANG 18432000HZ 30PPM 16	

COILS & FILTERS

BC91	9965 000 18585	BEAD CORE BFS3550R2FD8,R T/P	
BC92	9965 000 18585	BEAD CORE BFS3550R2FD8,R T/P	
L201	9965 000 25797	INDUCTOR 10UH 10%	/02/14
L301	9965 000 25797	INDUCTOR 10UH 10%	
L303	9965 000 25797	INDUCTOR 10UH 10%	
L304	9965 000 25797	INDUCTOR 10UH 10%	
L305	9965 000 25798	INDUCTOR 100UH 10%	
L306	9965 000 18641	100M K 6X6 L5 TP	
L307	9965 000 25797	INDUCTOR 10UH 10%	
L310	9965 000 18641	100M K 6X6 L5 TP	
L503	9965 000 18641	100M K 6X6 L5 TP	
L504	9965 000 18646	10M K 6X6 L5 TP	
L505	9965 000 25799	INDUCTOR 12UH	
L701	9965 000 18641	100M K 6X6 L5 TP	
L702	9965 000 18646	10M K 6X6 L5 TP	
L704	9965 000 18646	10M K 6X6 L5 TP	
L705	9965 000 18646	10M K 6X6 L5 TP	

L7V1	9965 000 18641	100M K 6X6 L5 TP	
L801	9965 000 18641	100M K 6X6 L5 TP	
L802	9965 000 18641	100M K 6X6 L5 TP	
L803	9965 000 18641	100M K 6X6 L5 TP	
L901	9965 000 19456	10UH, CHIP2012 CERATECH R/TP	
L902	9965 000 19456	10UH, CHIP2012 CERATECH R/TP	
L903	9965 000 19456	10UH, CHIP2012 CERATECH R/TP	
L904	9965 000 19456	10UH, CHIP2012 CERATECH R/TP	
L905	9965 000 19456	10UH, CHIP2012 CERATECH R/TP	
L906	9965 000 19456	10UH, CHIP2012 CERATECH R/TP	
L907	9965 000 19456	10UH, CHIP2012 CERATECH R/TP	
L908	9965 000 19456	10UH, CHIP2012 CERATECH R/TP	
L909	9965 000 19456	10UH, CHIP2012 CERATECH R/TP	
L910	9965 000 19456	10UH, CHIP2012 CERATECH R/TP	
L911	9965 000 18646	10M K 6X6 L5 TP	
L911 *	9965 000 19456	10UH, CHIP2012 CERATECH R/TP	
L912	9965 000 25591	INDUCTOR 1UH , CHIP2012	
L913	9965 000 25591	INDUCTOR 1UH , CHIP2012	

DIODES

D301	9965 000 18686	RL104 R. TP GULF SEMICONDUCTOR	
D903	9965 000 18565	RL104F TP RECTRON NON 400V 1A	
D904	9965 000 18565	RL104F TP RECTRON NON 400V 1A	
LD501	9965 000 25800	LED WITH HOLDER	
ZD801	9965 000 25616	ZENER Z02W7.5V KEC R/TP SOT23 25	
ZD802	9965 000 25616	ZENER Z02W7.5V KEC R/TP SOT23 25	
ZD901	5322 130 33763	BZX84-C7V5	
ZD902	5322 130 33763	BZX84-C7V5	
ZD903	5322 130 33763	BZX84-C7V5	
ZD904	5322 130 33763	BZX84-C7V5	
ZD905	5322 130 33763	BZX84-C7V5	
ZD906	5322 130 33763	BZX84-C7V5	
ZD907	5322 130 33763	BZX84-C7V5	
ZD908	5322 130 33763	BZX84-C7V5	

TRANSISTORS

Q301	9965 000 25809	CHIP KTC3875S-GR-T1(ALG) KEC	
Q302	9965 000 16622	CHIP TRANSISTOR KTA1504GR-RTK	
Q303	9965 000 25809	CHIP KTC3875S-GR-T1(ALG) KEC	
Q304	9965 000 25809	CHIP KTC3875S-GR-T1(ALG) KEC	
Q306	9965 000 18651	2SC5344Y TP	
Q306 *	9965 000 25599	KTC3203 KEC TP TO92 50V 150MA	
Q311	9965 000 25809	CHIP KTC3875S-GR-T1(ALG) KEC	
Q501	9965 000 25809	CHIP KTC3875S-GR-T1(ALG) KEC	
Q503	9965 000 25810	KTA1273-TP-Y (KTA966A)KEC	
Q504	9965 000 16622	CHIP TRANSISTOR KTA1504GR-RTK	
Q505	9965 000 16622	CHIP TRANSISTOR KTA1504GR-RTK	
Q506	9965 000 25809	CHIP KTC3875S-GR-T1(ALG) KEC	
Q514	9965 000 16624	CHIP TRANSISTOR KRC103S RTK	
Q515	9965 000 16624	CHIP TRANSISTOR KRC103S RTK	
Q701	9965 000 16624	CHIP TRANSISTOR KRC103S RTK	
Q7S1	9965 000 25809	CHIP KTC3875S-GR-T1(ALG) KEC	/02

ELECTRICAL PARTS LIST**TRANSISTORS**

Q704	9965 000 25810	KTA1273-TP-Y (KTA966A)KEC
Q901	9965 000 16622	CHIP TRANSISTOR KTA1504GR-RTK
Q902	9965 000 25809	CHIP KTC3875S-GR-T1(ALG) KEC
Q903	9965 000 25809	CHIP KTC3875S-GR-T1(ALG) KEC
Q904	9965 000 16624	CHIP TRANSISTOR KRC103S RTK
Q905	9965 000 16622	CHIP TRANSISTOR KTA1504GR-RTK
Q907	9965 000 11427	KRA103S (SOP)
Q908	9965 000 16624	CHIP TRANSISTOR KRC103S RTK
Q909	9965 000 16624	CHIP TRANSISTOR KRC103S RTK
Q910	9965 000 25809	CHIP KTC3875S-GR-T1(ALG) KEC
Q911	9965 000 25809	CHIP KTC3875S-GR-T1(ALG) KEC
Q912	9965 000 25809	CHIP KTC3875S-GR-T1(ALG) KEC

INTEGRATED CIRCUITS

IC201	9965 000 25670	LA70100M - TRM SANYO 30PIN /02/14
IC301	9965 000 18630	LA71750EM SANYO 100PIN QFP TRA
IC302	9965 000 25791	NJM2234L SIP8 ST S/W IC(3INPUT
IC501	9965 000 25792	MN101DF10G FLASH MATSUSHITA 10
IC503	9965 000 18632	CAT24W16P 8P DIP ST 16K SERIAL
IC504	9965 000 18633	KIA7031P 3P 3.1V RESET(TAPING)
IC505	9965 000 18634	KIA7042P
IC751	9965 000 14760	AUD UP MSP3417G-QG-B8-V3
IC7V1	9965 000 25582	SDA5650X GEG MICRONAS 20PIN SO
IC801	9352 631 46557	TDA9605H/N2
IC804	9965 000 25793	MM1231XFBE MITSUMI 16PIN SOP R
IC901	9965 000 18573	MM1623XFBE MITSUMI 28PIN SOP R
IC902	9965 000 25794	MM1225XFBE MITSUMI 8PIN SOP R/
IC903	9965 000 25794	MM1225XFBE MITSUMI 8PIN SOP R/

* ALTERNATIVE PART CODE

Note: Only the parts mentioned in this list are normal service spare parts.

FRONT JACK PC BOARD**MISCELLANEOUS**

JK761	9965 000 25958	S-VIDEO SOCKET
JK765	9965 000 25959	DV-IN SOCKET
JK762	9965 000 26261	CINCH SOCKET WHITE
JK763	9965 000 26262	CINCH SOCKET RED
JK764	9965 000 26263	CINCH SOCKET YELLOW

COILS & FILTERS

F701	9965 000 18585	BEAD CORE BFS3550R2FD8,R T/P
F702	9965 000 18585	BEAD CORE BFS3550R2FD8,R T/P
F703	9965 000 18585	BEAD CORE BFS3550R2FD8,R T/P
F704	9965 000 18585	BEAD CORE BFS3550R2FD8,R T/P
L701	9965 000 18585	BEAD CORE BFS3550R2FD8,R T/P
L702	9965 000 18585	BEAD CORE BFS3550R2FD8,R T/P
L703	9965 000 18585	BEAD CORE BFS3550R2FD8,R T/P
L704	9965 000 18648	100M K 2.3X3.4 L5 TP
L705	9965 000 18648	100M K 2.3X3.4 L5 TP

TIMER (DISPLAY) + KEY PC BOARDS**MISCELLANEOUS**

C602	9965 000 25948	TANTALUM CAP 470UF 6.3V 20%
DIG601	9965 000 25949	FTD DISPLAY HNV-12SM79T
P6M01	9965 000 25953	CONN. PLUG TUC-P12X-B1 12P
P6M03	9965 000 25954	CONN. PLUG TUC-P05X-B1 5PIN
L601	9965 000 19251	820UH 5% 4X5 TR5
RC601	9965 000 25955	REM RECEIVER TSOP2438SB1
RC601 *	9965 000 25956	REM RECEIVER TSOP1838RF1
SW601	9965 000 19257	TACT SW THVV502GAA 12V
SW601 *	9965 000 25957	TACT SW SKQNQED 12V 50MA
SW602	9965 000 19257	TACT SW THVV502GAA 12V
SW602 *	9965 000 25957	TACT SW SKQNQED 12V 50MA
SW603	9965 000 19257	TACT SW THVV502GAA 12V
SW603 *	9965 000 25957	TACT SW SKQNQED 12V 50MA
SW604	9965 000 19257	TACT SW THVV502GAA 12V
SW604 *	9965 000 25957	TACT SW SKQNQED 12V 50MA
SW605	9965 000 19257	TACT SW THVV502GAA 12V
SW605 *	9965 000 25957	TACT SW SKQNQED 12V 50MA
SW606	9965 000 19257	TACT SW THVV502GAA 12V
SW606 *	9965 000 25957	TACT SW SKQNQED 12V 50MA
SW607	9965 000 19257	TACT SW THVV502GAA 12V
SW607 *	9965 000 25957	TACT SW SKQNQED 12V 50MA
SW608	9965 000 19257	TACT SW THVV502GAA 12V
SW610	9965 000 19257	TACT SW THVV502GAA 12V
SW610 *	9965 000 25957	TACT SW SKQNQED 12V 50MA
SW611	9965 000 19257	TACT SW THVV502GAA 12V
SW611 *	9965 000 25957	TACT SW SKQNQED 12V 50MA
SW612	9965 000 19257	TACT SW THVV502GAA 12V
SW612 *	9965 000 25957	TACT SW SKQNQED 12V 50MA
SW613	9965 000 19257	TACT SW THVV502GAA 12V

ELECTRICAL PARTS LIST**MISCELLANEOUS**

SW613 *	9965 000 25957	TACT SW SKQNQED 12V 50MA
SW614	9965 000 19257	TACT SW THVV502GAA 12V
SW614 *	9965 000 25957	TACT SW SKQNQED 12V 50MA

DIODES

LED601	4822 130 83976	DL-11S2RNS
LED601 *	9965 000 25951	SA3417 TP RED
LED602	9965 000 25952	SY3517 BK AMBER
LED603	9965 000 25952	SY3517 BK AMBER
LED604	9965 000 25952	SY3517 BK AMBER
LED605	9965 000 25952	SY3517 BK AMBER
LED606	4822 130 83976	DL-11S2RNS
LED606 *	9965 000 25951	SA3417 TP RED
LED607	4822 130 83976	DL-11S2RNS
LED607 *	9965 000 25951	SA3417 TP RED

TRANSISTORS & INTEGRATED CIRCUITS

IC601	9965 000 25950	PT6315 PTC 44 LQFP TRAY VFD DR
Q601	9965 000 25809	CHIP KTC3875S-GR-T1(ALG) KEC
Q604	9965 000 25809	CHIP KTC3875S-GR-T1(ALG) KEC

* ALTERNATIVE PART CODE

Note: Only the parts mentioned in this list are normal service spare parts.

VDR (DIGITAL) BOARD**MISCELLANEOUS**

CON401	9965 000 25920	FLEX SOCKET 40PIN VERT
PN301	9965 000 25941	CONN SOCKET 15PIN VERT
PN302	9965 000 25941	CONN SOCKET 15PIN VERT
PN303	9965 000 25942	FLEX SOCKET 15PIN VERT
PN304	9965 000 25943	FLEX SOCKET 30PIN VERT
X101	9965 000 25945	CRYSTAL RESONATOR 13.5 MHZ
X501	9965 000 25946	CRYSTAL RESONATOR 14.31818MHZ
X601	9965 000 25947	CRYSTAL RESONATOR 24.576MHZ

CAPACITORS

C107	9965 000 25907	TANTALUM CAP 47UF 10V 20%
C109	9965 000 25908	TANTALUM CAP 10UF 10V
C121	9965 000 25908	TANTALUM CAP 10UF 10V
C123	9965 000 25908	TANTALUM CAP 10UF 10V
C135	9965 000 25908	TANTALUM CAP 10UF 10V
C136	9965 000 25908	TANTALUM CAP 10UF 10V
C149	9965 000 25908	TANTALUM CAP 10UF 10V
C162	9965 000 25908	TANTALUM CAP 10UF 10V
C303	9965 000 25910	TANTALUM CAP 330UF 6.3V 20%
C303 *	9965 000 25909	TANTALUM CAP 330UF 6.3V 20%
C305	9965 000 25911	ELCAP 220UF 6.3V
C306	9965 000 25912	TANTALUM CAP 22UF 10V
C308	9965 000 25911	ELCAP 220UF 6.3V
C309	9965 000 25911	ELCAP 220UF 6.3V
C311	9965 000 25911	ELCAP 220UF 6.3V
C312	9965 000 25911	ELCAP 220UF 6.3V
C313	9965 000 25911	ELCAP 220UF 6.3V
C318	9965 000 25911	ELCAP 220UF 6.3V
C320	9965 000 25911	ELCAP 220UF 6.3V
C403	9965 000 25912	TANTALUM CAP 22UF 10V
C504	9965 000 25913	ELCAP 100UF 16V
C507	9965 000 25914	ELCAP 22UF 16V
C508	9965 000 25915	ELCAP 10UF 16V
C509	9965 000 25915	ELCAP 10UF 16V
C510	9965 000 25915	ELCAP 10UF 16V
C519	9965 000 25916	TANTALUM CAP 10UF 16V 20%
C535	9965 000 25916	TANTALUM CAP 10UF 16V 20%
C537	9965 000 25916	TANTALUM CAP 10UF 16V 20%
C628	9965 000 25917	TANTALUM CAP 1UF 16V
C629	9965 000 25917	TANTALUM CAP 1UF 16V
C630	9965 000 25912	TANTALUM CAP 22UF 10V
C801	9965 000 25915	ELCAP 10UF 16V
C802	9965 000 25915	ELCAP 10UF 16V
C804	9965 000 25915	ELCAP 10UF 16V
C806	9965 000 25915	ELCAP 10UF 16V
C807	9965 000 25915	ELCAP 10UF 16V
C810	9965 000 25918	ELCAP 47UF 16V
C815	9965 000 25914	ELCAP 22UF 16V
C818	9965 000 25914	ELCAP 22UF 16V
C819	9965 000 25914	ELCAP 22UF 16V

ELECTRICAL PARTS LIST**CAPACITORS**

C825	9965 000 25914	ELCAP 22UF 16V
C828	9965 000 25914	ELCAP 22UF 16V
C829	9965 000 25914	ELCAP 22UF 16V
C830	9965 000 25914	ELCAP 22UF 16V
C831	9965 000 25918	ELCAP 47UF 16V
C833	9965 000 25919	ELCAP 1UF 50V 20%
C837	9965 000 25918	ELCAP 47UF 16V
C840	9965 000 25915	ELCAP 10UF 16V
C842	9965 000 25914	ELCAP 22UF 16V
C1201	9965 000 25843	TANTALUM CAP 10UF 6.3V 20%
C1208	9965 000 25843	TANTALUM CAP 10UF 6.3V 20%
C1262	9965 000 25843	TANTALUM CAP 10UF 6.3V 20%
C1272	9965 000 25843	TANTALUM CAP 10UF 6.3V 20%
C1282	9965 000 25909	TANTALUM CAP 330U F6.3V 20%
C1282 *	9965 000 25910	TANTALUM CAP 330UF 6.3V 20%
C1287	9965 000 25910	TANTALUM CAP 330UF 6.3V 20%
C1287 *	9965 000 25909	TANTALUM CAP 330U F6.3V 20%
C1288	9965 000 25910	TANTALUM CAP 330UF 6.3V 20%
C1288 *	9965 000 25909	TANTALUM CAP 330U F6.3V 20%
C1289	9965 000 25910	TANTALUM CAP 330UF 6.3V 20%
C1289 *	9965 000 25909	TANTALUM CAP 330U F6.3V 20%
C1291	9965 000 25839	TANTALUM CAP 22UF 16V 20%
C1293	9965 000 25909	TANTALUM CAP 330U F6.3V 20%
C1293 *	9965 000 25910	TANTALUM CAP 330UF 6.3V 20%
C1295	9965 000 25910	TANTALUM CAP 330UF 6.3V 20%
C1295 *	9965 000 25909	TANTALUM CAP 330U F6.3V 20%
C5108	9965 000 25916	TANTALUM CAP 10UF 16V 20%
C5109	9965 000 25916	TANTALUM CAP 10UF 16V 20%
C5110	9965 000 25916	TANTALUM CAP 10UF 16V 20%

COILS & FILTERS

FL501	9965 000 25921	INDUCTOR, CHIP HB-1M1608-102JT
FL502	9965 000 25921	INDUCTOR, CHIP HB-1M1608-102JT
FL503	9965 000 25921	INDUCTOR, CHIP HB-1M1608-102JT
FL504	9965 000 25921	INDUCTOR, CHIP HB-1M1608-102JT
FL505	9965 000 25921	INDUCTOR, CHIP HB-1M1608-102JT
FL506	9965 000 25921	INDUCTOR, CHIP HB-1M1608-102JT
FL507	9965 000 25921	INDUCTOR, CHIP HB-1M1608-102JT
L102	9965 000 18575	HB-1M2012-102JT CERATECH TP
L103	9965 000 18575	HB-1M2012-102JT CERATECH TP
L104	9965 000 18575	HB-1M2012-102JT CERATECH TP
L105	9965 000 18575	HB-1M2012-102JT CERATECH TP
L106	9965 000 18575	HB-1M2012-102JT CERATECH TP
L107	9965 000 18575	HB-1M2012-102JT CERATECH TP
L302	9965 000 25939	BEAD C,HH-1H4532-121JT
L303	9965 000 25939	BEAD C,HH-1H4532-121JT
L304	9965 000 25939	BEAD C,HH-1H4532-121JT
L305	9965 000 25939	BEAD C,HH-1H4532-121JT
L306	9965 000 25939	BEAD C,HH-1H4532-121JT
L307	9965 000 25939	BEAD C,HH-1H4532-121JT
L308	9965 000 25939	BEAD C,HH-1H4532-121JT
L501	9965 000 18575	HB-1M2012-102JT CERATECH TP

L502	9965 000 18575	HB-1M2012-102JT CERATECH TP
L503	9965 000 18575	HB-1M2012-102JT CERATECH TP
L504	9965 000 18575	HB-1M2012-102JT CERATECH TP
L607	9965 000 18575	HB-1M2012-102JT CERATECH TP
L608	9965 000 18575	HB-1M2012-102JT CERATECH TP
L801	9965 000 25871	INDUCTOR,CHIP NLC322522T-100K 10
L802	9965 000 25871	INDUCTOR,CHIP NLC322522T-100K 10
L803	9965 000 25871	INDUCTOR,CHIP NLC322522T-100K 10
L804	9965 000 25871	INDUCTOR,CHIP NLC322522T-100K 10
L1201	9965 000 25939	BEAD C,HH-1H4532-121JT
L1202	9965 000 18575	HB-1M2012-102JT CERATECH TP
L1203	9965 000 25939	BEAD C,HH-1H4532-121JT
L1204	9965 000 25939	BEAD C,HH-1H4532-121JT
L1205	9965 000 25939	BEAD C,HH-1H4532-121JT
L5101	9965 000 18575	HB-1M2012-102JT CERATECH TP
L5102	9965 000 18575	HB-1M2012-102JT CERATECH TP
L5103	9965 000 18575	HB-1M2012-102JT CERATECH TP
L6903	9965 000 18575	HB-1M2012-102JT CERATECH TP

DIODES

D101	4822 130 83649	1SS355
D102	4822 130 83649	1SS355
LD301	9965 000 25940	SML-010VT R/TP RED .

INTEGRATED CIRCUITS

IC101	9965 000 25922	DMN-8602 LSI LOGIC 308PIN,BGA
IC301A	9965 000 25926	FLASH 29LV320ATTC-90 W/SW PROG L
IC302	9965 000 25927	74HCT125 PHILIPS 14PIN,TSSOP R
IC304	9965 000 25928	S524A60X51-SCT0 8P SOP TP EEP
IC402	9965 000 25929	74LVC08APW PHILIPS 14PIN TSSOP
IC406	9965 000 25930	74LVT16373A DGG PHILIPS 48PIN
IC409	9965 000 25931	74LVC04APW PHILIPS 14PIN TSSOP
IC501	9965 000 25932	NJM2274R JRC VSP8 R/TP LOW POW
IC502	9965 000 25933	TVP5146PFP TEXAS INSTRUMENT 80
IC601	9965 000 25935	TSB41AB1PHP TEXAS INSTRUMENT 4
IC801	9965 000 25936	MC33202DR2 ON SEMI 8PIN SOP R/
IC802	9965 000 25937	CS4271 CIRRUS LOGIC 28PIN,TSSO
IC803	9965 000 25936	MC33202DR2 ON SEMI 8PIN SOP R/
IC804	9965 000 25938	NJM5532 OP AMP JRC
IC1201	9965 000 25923	LP2995 NATIONAL SEMICONDUCTOR
IC1202	9965 000 25924	HYB25D256160CE-6 INFINEON 66PI
IC1202 *	9965 000 25925	HY5DU561622C HYNIX 66PIN,TSOP
IC1203	9965 000 25924	HYB25D256160CE-6 INFINEON 66PI
IC1203 *	9965 000 25925	HY5DU561622C HYNIX 66PIN,TSOP
IC5101	9965 000 25934	SAA7128 QFP44 BK DIGITAL VIDEO

TRANSISTORS

Q402	9965 000 16624	CHIP TRANSISTOR KRC103S RTK
Q403	9965 000 16624	CHIP TRANSISTOR KRC103S RTK
Q404	9965 000 16624	CHIP TRANSISTOR KRC103S RTK
Q803	9965 000 25944	KTC3875S-Y-T1(ALY) KEC TP TO9
Q804	9965 000 25944	KTC3875S-Y-T1(ALY) KEC TP TO9

ELECTRICAL PARTS LIST**TRANSISTORS**

Q807	9965 000 11427	KRA103S (SOP)
Q808	9965 000 11427	KRA103S (SOP)

* ALTERNATIVE PART CODE

Note: Only the parts mentioned in this list are normal service spare parts.

POWER (SMPS) BOARD MODULE**MISCELLANEOUS**

BC101	9965 000 25876	BEAD CORE BFD3514R2F,R T/P
BC102	9965 000 25876	BEAD CORE BFD3514R2F,R T/P
BD101	9965 000 25877	GBL08 VISHAY BK GBL 800V 4A 20
F101	4822 070 31602	△ FUSE T1.6A 250V
PW101	9965 000 25897	CONN SOCKET 2PIN, AC IN
T101	9965 000 25900	△ EER2828 COMPLEX MODEL SOOJUNG
T102	9965 000 25901	△ EER2828 COMPLEX MODEL SOOJUNG
V101	9965 000 19235	△ SVC681D-10A SAMHWA 4.O CUT

CAPACITORS

C101	9965 000 25878	△ PCX2 275V 0.1UF,M (PILKO)
C102	9965 000 25878	△ PCX2 275V 0.1UF,M (PILKO)
C103	9965 000 25879	ELCAP 150UF 400V 20%
C105	9965 000 18669	0.01UF D 630V K PE NI TP
C106	9965 000 25551	CAP HIGH-VOL 68PF 1KV
C110	9965 000 18672	△ 1000PF 400V M E(Z5U) R
C111	9965 000 18672	△ 1000PF 400V M E(Z5U) R
C115	9965 000 18669	0.01UF D 630V K PE NI TP
C116	9965 000 25551	CAP HIGH-VOL 68PF 1KV
C122	4822 124 40201	1000UF 20% 16V
C123	9965 000 25552	ELCAP 2200UF 16V 20% BK7.5 FL
C125	4822 124 40184	1000UF20% 10V
C126	9965 000 25552	ELCAP 2200UF 16V 20% BK7.5 FL
C129	9965 000 25552	ELCAP 2200UF 16V 20% BK7.5 FL
C139	9965 000 25880	1000UF KMG 25V 20% BULK FL

RESISTORS

R100	9965 000 19226	1.5M OHM 1/2 W 5.00% MF10
R103	9965 000 19228	56K OHM 2 W 5.00% TR
R112	9965 000 25898	100K OHM 2 W 5.00% TR
R115	9965 000 25898	100K OHM 2 W 5.00% TR
R155	9965 000 25899	56 OHM 1 W 5.00% TR
TH01	9965 000 25902	THERMISTOR, PTC 4.0OHM 15

COILS & FILTERS

L102	9965 000 25895	△ SQ2626 SAMWAH TECOM BK SQ2424
L121	9965 000 19212	CHOCK(22MH) 5MM TOKO TP
L121 *	9965 000 25588	CHOKO COIL TDK 22UH(=633-088G
L122	9965 000 19212	CHOCK(22MH) 5MM TOKO TP
L122 *	9965 000 25588	CHOKO COIL TDK 22UH(=633-088G
L123	9965 000 25896	BAR CHOKO COIL 2 PIN 10 UHCCAR
L125	9965 000 18641	100M K 6X6 L5 TP
L127	9965 000 19212	CHOCK(22MH) 5MM TOKO TP

DIODES

D101	9965 000 18682	ERA22-10 KFLB,TP ,R T/P,FUJI
D102	9965 000 18683	EU01W(R-FORM) TP SANKEN
D103	9965 000 18682	ERA22-10 KFLB,TP ,R T/P,FUJI
D104	9965 000 18683	EU01W(R-FORM) TP SANKEN

ELECTRICAL PARTS LIST

DIODES

D121	9965 000 25881	D3S6M SHINDENGEN BK AX14 60V 1
D121 *	9965 000 25882	SB360-24A GULF BK DO201AD 60V
D122	9965 000 18687	B10A45V1 BK KEC TO220 45V 10A
D123	9965 000 18687	B10A45V1 BK KEC TO220 45V 10A
D124	9965 000 25883	B5A60VI , 4MM CUTTING KEC ST T
D125	9965 000 18684	HER302 BK RECTRON DO201AD 100V
D125 *	9965 000 25554	DIODE RU4YX BK
D126	9965 000 18684	HER302 BK RECTRON DO201AD 100V
D126 *	9965 000 25554	DIODE RU4YX BK
D127	9965 000 18565	RL104F TP RECTRON NON 400V 1A
D128	9965 000 18683	EU01W(R-FORM) TP SANKEN
D129	9965 000 18565	RL104F TP RECTRON NON 400V 1A
D130	9965 000 18683	EU01W(R-FORM) TP SANKEN
D132	9965 000 18686	RL104 R. TP GULF SEMICONDUCTOR
D133	9965 000 18686	RL104 R. TP GULF SEMICONDUCTOR
D134	4822 130 32778	1SS133
D151	9965 000 18686	RL104 R. TP GULF SEMICONDUCTOR
D155	9965 000 18686	RL104 R. TP GULF SEMICONDUCTOR
ZD101	9965 000 25903	MTZ22B T-77 TP ROHM
ZD101 *	9965 000 25559	ZENER UZ-22BSB 26MM
ZD102	9965 000 25903	MTZ22B T-77 TP ROHM
ZD102 *	9965 000 25559	ZENER UZ-22BSB 26MM
ZD151	9965 000 25904	GDZJ3.3B TP GRANDE DO34 0.5W 3
ZD151 *	9965 000 25905	MTZJ3.3B TP ROHM-K DO34 0.5W 3
ZD151 *	9965 000 25906	MTZ3.3B,T-77(26MMTP) TP ROHM -
ZD151 *	9965 000 19243	UZ-3.3BSB 26MM TP PYUNG CHANG
ZD152	9965 000 25613	ZENER UZ-13BSA 26MM
ZD153	9965 000 19244	UZ-30BSC 26MM PYUNG CHANG TP D

INTEGRATED CIRCUITS

IC101	9965 000 25555	IC FSDL0365RN 8PIN,DIP
IC102	9965 000 18689	△ LTV-817B,PHOTO COUPLER(LITEON)
IC102 *	9965 000 25884	△ PC123YN2 SHARP PHOTOCOUPLER
IC103	9965 000 25885	KA431AZ (LM431AZ)
IC103 *	4822 209 12767	KIA431
IC104	9965 000 25555	IC FSDL0365RN 8PIN,DIP
IC105	9965 000 18689	△ LTV-817B,PHOTO COUPLER(LITEON)
IC105 *	9965 000 25884	△ PC123YN2 SHARP PHOTOCOUPLER
IC106	9965 000 25885	KA431AZ (LM431AZ)
IC106 *	4822 209 12767	KIA431
IC151	9965 000 25886	KA278R05TSTU FAIRCHILD 4PIN,TO
IC151 *	9965 000 25887	KIA278R05PI-CU KEC 4PIN,TO220I
IC152	9965 000 25888	KIA78R25PICU KEC 4PIN,TO-220IS
IC152 *	9965 000 25889	G9125 GMT 4PIN,TO 220F-4L ST 1
IC154	9965 000 25890	G9233 GMT 4PIN, TO 220F-4L ST
IC154 *	9965 000 19210	KIA278R33PI-CU KEC 4PIN TO-220
IC154 *	9965 000 25891	KA278R33TSTU FAIRCHILD 4PIN TO
IC157	9965 000 25892	KA278R12TSTU FAIRCHILD 4P TO-2
IC157 *	9965 000 25893	KIA278R12PI-CU KEC 4PIN,TO220I
IC160	9965 000 25894	PQ070VK02LZH SHARP 5PIN,DIP ST

TRANSISTORS

Q120	4822 130 63857	KTD1414
Q121	4822 130 10145	KRA103M
Q122	4822 130 41319	2SC1815BL
Q122 *	4822 130 63859	KTC3199-BL
Q123	9965 000 19225	KTA1268-BL TP KEC
Q124	9965 000 25810	KTA1273-TP-Y (KTA966A)KEC
Q125	4822 130 41319	2SC1815BL
Q125 *	4822 130 63859	KTC3199-BL
Q126	4822 130 41306	2SC1815GR

* ALTERNATIVE PART CODE

Note: Only the parts mentioned in this list are normal service spare parts.

REVISION LIST

Version 1.0

- * Initial release

Version 1.1

- * Parts list correction to conform with component repair policy