

1. Body

Exploded View

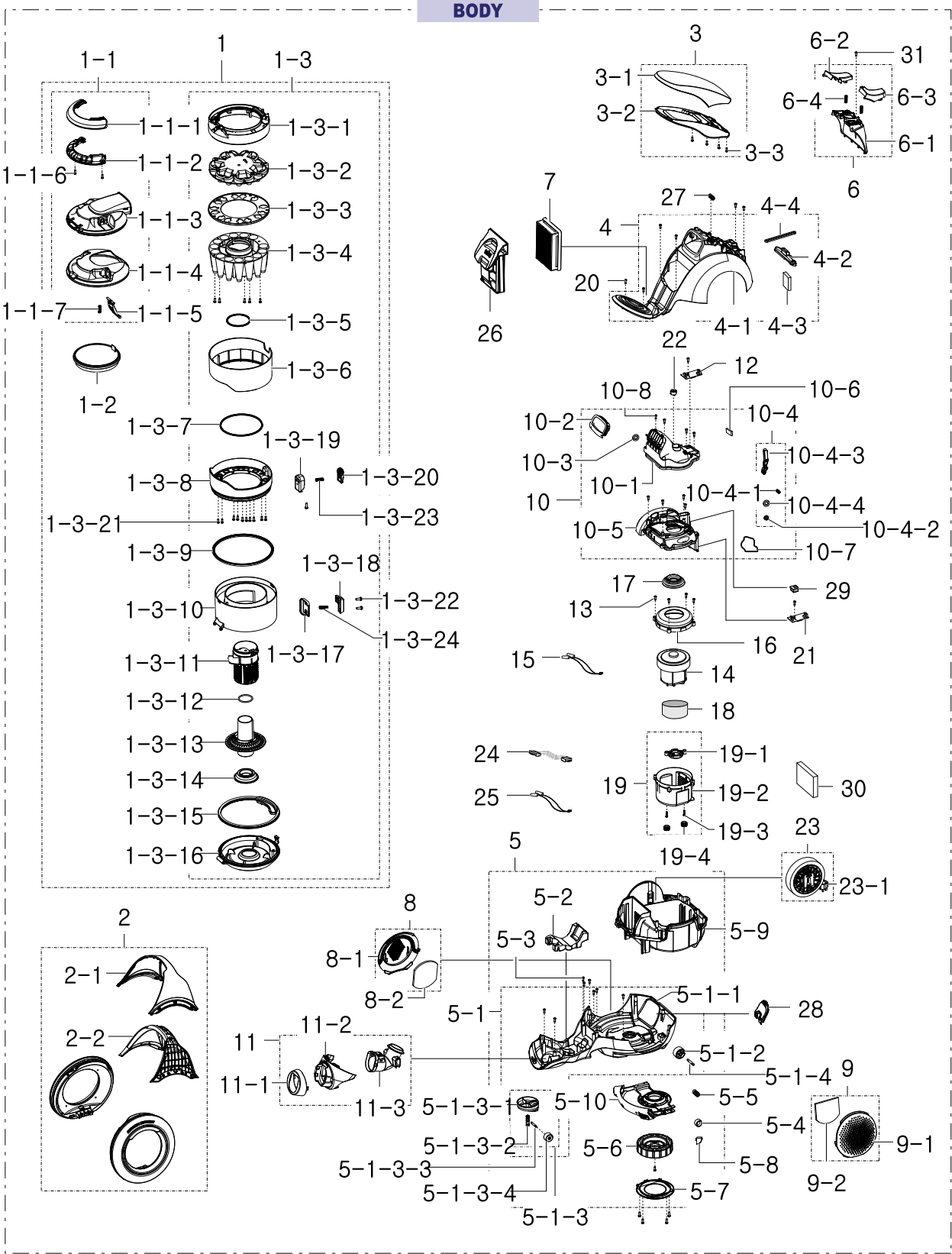

Parts List

No.	Lvl.	Loc.	Material Code	Description & Specification	SNA	Qty.
1	1		DJ97-01975A	ASSY CYCLONE CASE; SC20F70HA	SA	1
1-1	2		DJ97-01976A	ASSY CYCLONE COVER; SC20F70HA	SA	1
1-1-1	3		DJ64-01149A	HANDLE CYCLONE-UP; SC20F70HA,ABS,-,LX-098	SNA	1
1-1-2	3		DJ64-01150A	HANDLE CYCLONE-LOW; SC21F70H,ABS,-,HG-076	SNA	1
1-1-3	3		DJ63-01299A	COVER CYCLONE-UP; SC21F70H,ABS,-,HB,EBONY	SNA	1
1-1-4	3		DJ64-01152A	DECORATION CYCLONE-UP; SC20F70HA,ABS,-,TI	SNA	1
1-1-5	3		DJ66-00694A	LEVER SAFETY; SC21F50VA,ABS,T2.0,-,HG-076	SA	1
1-1-6	3	RV005	6003-000170	SCREW-TAPTYPE; PH,+,-,B,M4,L12,ZPC(WHT),S	SNA	2
1-1-7	3		DJ61-01383A	SPRING ETC-CASE; VC-B715U,SUS316,CD0.6,ID	SNA	1
1-2	2		DJ63-01285A	FILTER CYCLONE; SC21F50VA,PU FOAM,W142.5,	SA	1
1-3	2	RL005	DJ97-01981A	ASSY CASE; SC20F70HA,SILVER	SA	1
1-3-1	3		DJ61-02069A	HOLDER FILTER; SC21F70H,ABS,-,EBONY BLACK	SNA	1
1-3-2	3		DJ61-02068A	CASE CYCLONE-UP; SC20F70HA,PP,-,BLACK,HB,	SNA	1
1-3-3	3		DJ63-01302A	GASKET CYCLONE-UP; SC20F70HA,TPV,BLACK,HA	SNA	1
1-3-4	3		DJ61-02073A	CASE CYCLONE-IN; SC20F70HA,PP,-,BLACK,HB,	SNA	1
1-3-5	3		DJ63-01013D	GASKET CASE; SC20F70HA,EPDM,L220,BLACK,OD	SNA	1
1-3-6	3		DJ64-01153A	DECORATION CYCLONE-MIDDLE; SC20F70HA,ABS,	SNA	1
1-3-7	3		DJ63-01091D	GASKET CYCLONE; SC20F70HA,TPV,400,BLACK,O	SNA	2
1-3-8	3		DJ63-01300A	GASKET CYCLONE; SC20F70HA,TPE,EBONY BLACK	SNA	1
1-3-9	3		DJ63-01304A	GASKET CYCLONE-MIDDLE; SC20F70HA,TPV,BLAC	SNA	1
1-3-10	3		DJ61-02071A	CASE CYCLONE-LOW; SC20F70HA,PC,-,GRAY TR-	SNA	1
1-3-11	3		DJ64-01148A	GRILLE CYCLONE; SC21F70H,PP,-,BLACK	SNA	1
1-3-12	3		DJ63-00509R	GASKET GRILLE CYCLONE; SC20F70HA,EVA FOAM	SNA	1
1-3-13	3		DJ67-00698A	CAP GRILLE; SC21F70H,PP,-,HB,BJ750,BLACK	SNA	1
1-3-14	3		DJ63-01303A	GASKET CYCLONE-IN; SC20F70HA,TPV,BLACK,HA	SNA	1

No.	Lvl.	Loc.	Material Code	Description & Specification	SNA	Qty.
1-3-15	3		DJ63-01305A	GASKET COVER CYCLONE; SC20F70HA,TPV,BLACK	SNA	1
1-3-16	3		DJ63-01301A	COVER CYCLONE-LOW; SC20F70HA,PC,-,HB,GRAY	SNA	1
1-3-17	3	RB095	DJ65-00082A	CLAMPER DUST; SC20F70HA,ABS,SOFT SKY BLUE	SNA	1
1-3-18	3		DJ61-02074A	HOLDER CLAMPER; SC21F70H,ABS,-,EBONY BLAC	SNA	1
1-3-19	3		DJ61-02075A	HOLDER CYCLONE; SC20F70HA,PC,-,GRAY TR-P,	SNA	1
1-3-20	3		DJ64-01151A	BUTTON CYCLONE; SC20F70HA,ABS,HB,SOFT SKY	SNA	1
1-3-21	3	RV005	6003-000171	SCREW-TAPTYPE; PH,+,NO,B,M4,L16,ZPC(WHT),	SNA	10
1-3-22	3	RV005	6003-000167	SCREW-TAPTYPE; PH,+,B,M3,L8,ZPC(BLK),SWRC	SNA	3
1-3-23	3	RP302	DJ61-01350A	SPRING ETC-BUTTON; SU9380,HSWR,COD0.6,ID6	SNA	1
1-3-24	3	RA094	DJ61-70001T	SPRING ETC-CLAMPER; VENUS,SUS,CD0.5,ID3.8	SNA	1
2	1		DJ97-01990D	ASSY WHEEL; SC20F70HA,URBAN GREEN	SA	1
2-1	2	RB163	DJ64-01142C	HANDLE-UP; SC20F70HB,ABS+PMMA,-,LX-0957,H	SNA	1
2-2	2	RB161	DJ64-01143A	HANDLE-LOW; SC20F70H,ABS,-,HG-0760GP,HB,E	SNA	1
3	1	RB026	DJ97-01978A	ASSY COVER DUST; SC20F70HA	SA	1
3-1	2	RB105	DJ63-01297A	COVER DUST; SC20F70HA,ABS,-,HB,EBONY BLAC	SA	1
3-2	2	RB106	DJ63-01294A	COVER DUST-LOW; SC21F70H,ABS,-,HB,EBONY B	SNA	1
3-3	2	RV005	6003-000170	SCREW-TAPTYPE; PH,+,-,B,M4,L12,ZPC(WHT),S	SNA	4
4	1	RB009	DJ97-01979A	ASSY BODY MID; SC20F70HA	SA	1
4-1	2	RB059	DJ61-02054A	BODY MID; SC20F70HA,ABS,-,EBONY BLACK	SNA	1
4-2	2		DJ64-01138A	WINDOW DISPLAY; SC21F70H,ABS,HB,TX-0510,D	SNA	1
4-3	2		DJ63-00508N	FILTER-SAFETY; SU8860,PU FOAM,T5,W70,L50,	SNA	1
4-4	2		DJ72-00373A	SPONGE-COVER; SC8680,CR FOAM,T2.5,W4.7,L3	SNA	1
5	1	RB002	DJ97-01977A	ASSY BODY BASE; SC20F70HA	SA	1
5-1	2		DJ94-00277A	ASSY PROCESS-BODY BASE INJ; SC20F70HA,BLA	SA	1
5-1-1	3	RB051	DJ61-02055A	BODY BASE; SC20F70HA,PP,-,BLACK	SNA	1
5-1-2	3	RP288	DJ66-00048F	ROLLER-BACK; VC-P910,PP,BLK	SA	1

Exploded Views and Parts List

No.	Lvl.	Loc.	Material Code	Description & Specification	SNA	Qty.
5-1-3	3	RP112	DJ66-00151C	ASSY ROLLER FRONT; FRONT,SC7800,BLACK + N	SA	1
5-1-3-1	4	RB168	DJ61-00320A	HOLDER-BACK; VC-8716V_BC-PJT,PA,-,BLACK,-	SNA	1
5-1-3-2	4	RP327	DJ66-00228A	SHAFT ROLLER; SC7800,ABS,BLACK,SD-0170	SNA	1
5-1-3-3	4	RP294	DJ70-30110A	SHAFT ROLLER-B; VC-DOM,MSWR,L26,OD3.9,ZPC	SA	1
5-1-3-4	4	RP101	DJ66-70100A	ASSY ROLLER; VC550P,NEUTRAL GRY	SNA	1
5-1-4	3	RP294	DJ70-30110A	SHAFT ROLLER-B; VC-DOM,MSWR,L26,OD3.9,ZPC	SA	1
5-2	2		DJ61-02057A	FRAME FRONT; SC20F70HA,PC,HB,NATURAL,-,30	SNA	1
5-3	3	RV005	6003-000171	SCREW-TAPTYPE; PH,+,NO,B,M4,L16,ZPC(WHT),	SNA	10
5-4	2		6601-002678	BEARING-BALL; 608ZZ Z3V3,ID8,OD22,L7,ZZ (SNA	2
5-5	2		DJ61-00092C	SPRING ETC-BUTTON; SC7950,HSWR,CD0.8,ID12	SNA	1
5-6	2		DJ61-02062A	HOLDER PIVOT; SC20F70HA,POM,-,NATURAL,-,K	SNA	1
5-7	2		DJ67-00695A	CAP BODY; SC21F70H,ABS,-,HB,HG-0760GP,EBO	SNA	1
5-8	2		DJ67-00701A	CAP SWITCH; SC21F70H,PP,-,HB,BJ750,BLACK	SNA	1
5-9	2		DJ97-01987A	ASSY CASE MOTOR-LOW; SC20F70HA,BLACK	SA	1
5-10	2	RB004	DJ97-01991A	ASSY BODY BUMPER; SC20F70HA	SA	1
6	1	RB042	DJ97-01986A	ASSY PANEL CONTROL; SC20F70HA,BLACK	SA	1
6-1	2	RB188	DJ64-01145A	PANEL CONTROL; SC20F70HA,ABS,-,HB,HG-0760	SNA	1
6-2	2		DJ64-01147A	BUTTON CORD REEL; SC20F70HA,PC,HB,BLACK,H	SNA	1
6-3	2	RB070	DJ64-01146A	BUTTON SWITCH; SC20F70HA,PC,HB,BLACK,HOT	SNA	1
6-4	2		DJ61-01478A	SPRING ETC-ROTARY; SC8680,HSWR,CD1.0,ID18	SNA	2
7	1	RA023	DJ97-01982A	ASSY FILTER OUTLET; SC20F70HA,HEPA,BLACK	SA	1
8	1		DJ97-01984A	ASSY GRILLE SIDE-RIGHT; SC20F70HA,BLACK	SA	1
8-1	2		DJ64-01140A	GRILLE BACK-RIGHT; SC20F70H,PP+TALC30%,HB	SNA	1
8-2	2		DJ63-01317A	FILTER OUTLET; SC20F70HA,PP,T5,W80,L98,BL	SNA	1
9	1		DJ97-01983A	ASSY GRILLE SIDE-LEFT; SC20F70HA,BLACK	SA	1

No.	Lvl.	Loc.	Material Code	Description & Specification	SNA	Qty.
9-1	2		DJ64-01139A	GRILLE BACK-LEFT; SC20F70H,PP+TALC30%,HB,	SNA	1
9-2	2		DJ63-01316A	FILTER OUTLET; SC20F70HA,PU FOAM,T5,W80,L	SNA	1
10	1		DJ97-01989A	ASSY CASE MOTOR-UP; SC20F70HA,BLACK	SA	1
10-1	2		DJ67-00697A	DUCT MOTOR; SC21F70H,PP,-,BJ750,BLACK	SNA	1
10-2	2		DJ63-01282A	GASKET DUCT; SC21F50VA,TPV,T1.9,BLACK	SNA	1
10-3	2	RB032	DJ97-01965A	ASSY DAMPER; SC21F50VA,BLACK	SA	1
10-4	2	RJ012	DJ97-01985A	ASSY LEVER BRAKE; SC20F70HA,TRP	SA	1
10-4-1	3		DJ61-70177D	SPRING ETC-BUTTON; F700G,HSWR,PI0.8,ID6.8	SNA	1
10-4-2	3		DJ66-00041A	SHAFT-BRAKE; VC-8600,POM	SNA	1
10-4-3	3	RJ075	DJ66-00701A	LEVER BRAKE; SC21F70H,PC,-,3022IR,NATUR	SNA	1
10-4-4	3	RJ098	DJ73-00016A	STOPPER-BRAKE; VC-8600,CR,BLK	SNA	1
10-5	2	RJ024	DJ61-02064A	CASE MOTOR-UP; SC20F70HA,PP+TALC30%,-,BLA	SNA	1
10-6	2		DJ63-00046B	SPONGE-H/SINK; SC6500,CR FOAM,T3,W41.8,L1	SNA	1
10-7	2	RB148	DJ63-00509M	GASKET BASE; SC9630,EVA FOAM,T3.5,L215,BL	SNA	1
10-8	2	RV005	6003-000171	SCREW-TAPTYPE; PH,+,NO,B,M4,L16,ZPC(WHT),	SNA	4
11	1	RB029	DJ97-01980A	ASSY COVER FRONT; SC20F70HA	SA	1
11-1	2		DJ64-01141A	DECORATION FRONT; SC20F70HA,ABS,-,TITANIU	SNA	1
11-2	2	RB108	DJ63-01295A	COVER FRONT; SC20F70HA,ABS,-,HB,EBONY BLA	SNA	1
11-3	2		DJ67-00696A	DUCT INLET; SC20F70HA,PC,-,3022R,BLACK	SNA	1
12	1		DJ92-00107A	ASSY PCB DISPLAY; DISPLAY,ADAGIO,52X40,N,	SA	1
13	2	RV005	6003-000171	SCREW-TAPTYPE; PH,+,NO,B,M4,L16,ZPC(WHT),	SNA	4
14	2		DJ31-00135A	MOTOR UNIVERSIAL FAN; 463.3.406-51,DOMEL,	SA	1
15	2		DJ39-00234B	WIRE HARNESS-MOTOR; YH396-03VRT, YEL,400m	SA	1
16	2		DJ61-02066A	CASE MOTOR-FRONT; SC21F70H,PP,-,BLACK,HB,	SA	1
17	2	RJ038	DJ63-01121B	CUSHION-MOTOR F; SC96E7,TPV,45,NTR	SA	1
18	2	RA093	DJ63-50138H	SPONGE-MOTOR; VC-SB930Z,SPONGE+FELT,T12,W	SNA	1
19	2		DJ97-01988A	ASSY CASE MOTOR-BACK; SC20F70HA,BLACK	SNA	1
19-1	3		DJ63-01281A	CUSHION RING; SC21F50VA,TPV,BLACK	SNA	1

Exploded Views and Parts List

No.	Lvl.	Loc.	Material Code	Description & Specification	SNA	Qty.
19-2	3		DJ61-02067A	CASE MOTOR-BACK; SC21F70H,PP,-,BLACK,HB,B	SNA	1
19-3	3	RV005	6003-000170	SCREW-TAPTYPE; PH,+,-,B,M4,L12,ZPC(WHT),S	SNA	2
19-4	3	RP221	DJ73-10120A	CUSHION-RING; NR,BLK,VC-6200	SNA	2
20	3	RV005	6003-000171	SCREW-TAPTYPE; PH,+,-,NO,B,M4,L16,ZPC(WHT),	SNA	10
21	1		DJ92-00104F	ASSY PCB MAIN; MAIN,PRESTO,105X77,N,85~26	SA	1
22	1	RJ101	DJ96-00106D	ASSY SWITCH-PRESSURE; SATURN,2100mmH2O,BL	SA	1
23	1	RJ008	DJ97-00832L	ASSY CORD REEL; SC8480,CP2 4.8,L9100,2*1.	SA	1
23-1	2	RP183	3903-000367	CBF-POWER CORD; AT,EU,EU3(CP2 4.8),WIRE(2	SNA	1
24	2		DJ39-00229A	WIRE HARNESS-PBA; PRESTO,UL1007,#24,SMH25	SA	1
25	2	RJ164	DJ39-00233A	WIRE HARNESS-SWITCH; ADAGIO,UL1007,#22,SM	SA	1
26	2		DJ61-02063A	HOLDER GRILLE; SC20F70HA,PP+TALC30%,-,BLA	SA	1
27	2	RP303	DJ61-70191C	SPRING ETC-BUTTON; REB-PJT,HSWR,PI1.2,ID1	SA	1
28	2	RB154	DJ63-00403A	GUARD CORD; SC4030,PP,-,BLACK	SC	1
29	2		DJ63-01306A	GASKET WIRE; SC21F70H,NBR,W17.6,L16.4,BLA	SA	1
30	2		DJ63-01318A	ABSORBER ETC; SC20F70HA,PU FOAM,T15,W72,L	SNA	1
31	2	RV005	6003-001050	SCREW-TAPTYPE; PH,+,-,2S,M4,L16,ZPC(BLK),SW	SNA	1

2. Accessory(Hose,Pipe,Accessory)

Exploded View

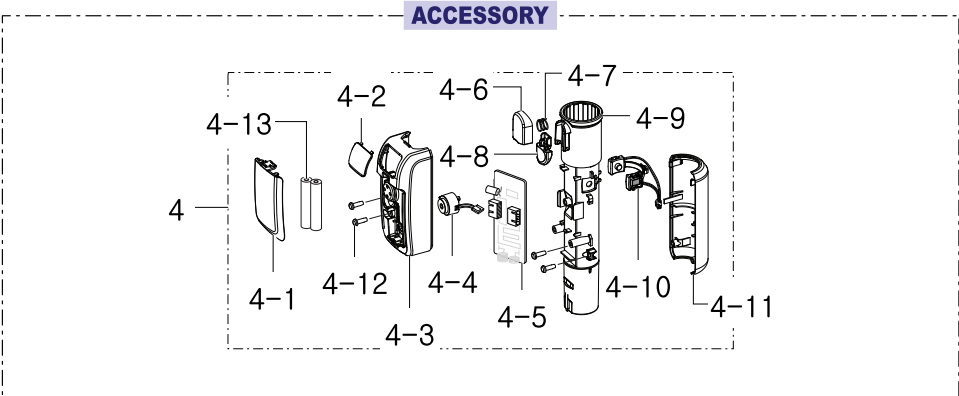
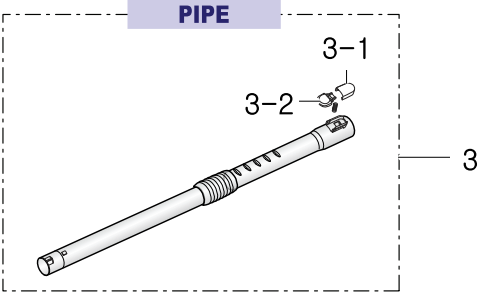
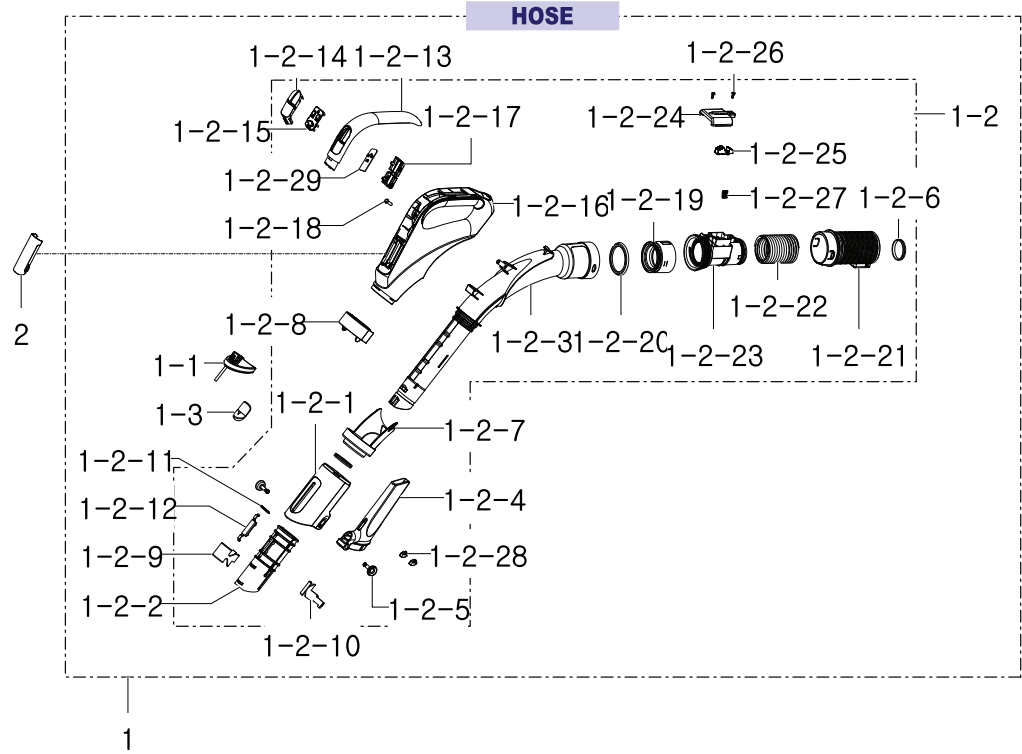

Parts List

No.	Lvl.	Loc.	Material Code	Description & Specification	SNA	Qty.
1	1	RL018	DJ97-01969A	ASSY HOSE; RCH-11R,BLACK,L1700,-,BUILT-IN	SNA	1
1-1	2		DJ61-02078A	HOLDER ETC; RCH-11R,ABS,-,EBONY BLACK,HB,	SA	1
1-2	2	RL020	DJ97-01992A	ASSY HOSE SUB; RCH-11R,-,L1700,-,ASSY SUB	SA	1
1-2-1	3		DJ61-02081A	HOLDER PIPE; RCH-11R,ABS,-,EBONY BLACK,-,	SNA	1
1-2-2	3		DJ61-02083A	GUIDE HANDLE; RCH-11R,PP+TALC30%,-,FC23	SNA	1
1-2-3	3		DJ62-00375A	PIPE HANDLE; RCH-10R,PP,-,BLACK,BJ750	SNA	1
1-2-4	3	RA078	DJ62-00373A	PIPE CREVICE; RCH-11R,ABS,-,EBONY BLACK,H	SNA	1
1-2-5	3		DJ66-00702A	SHAFT ETC; RCH-11R,ABS,EBONY BLACK,HG-076	SNA	2
1-2-6	3		DJ73-20100A	SEAL-PIPE; VC-8500,NBR,BLK	SNA	2
1-2-7	3		DJ67-00700A	CAP HANDLE BODY; RCH-10R,ABS,-,HG-0760G	SNA	1
1-2-8	3		DJ67-00699A	CAP HANDLE; RCH-11R,ABS,-,HG-0760GP,EBO	SNA	1
1-2-9	3		DJ64-00850A	LOCKER-SLIDE L; CLOVER-PJT,ABS,LIGHT GRY	SNA	1
1-2-10	3		DJ64-00851A	LOCKER-SLIDE R; CLOVER-PJT,ABS,LIGHT GRY	SNA	1
1-2-11	3		DJ61-01603A	SPRING ETC-PIPE; CLOVER-PJT,HSWR,PI0.5,ID	SNA	1
1-2-12	3		DJ64-00849A	LOCKER-PIPE; CLOVER-PJT,PA66,NTR	SNA	1
1-2-13	3	RB112	DJ63-01307A	COVER HANDLE; RCH-10R,ABS,-,HB,TITANIUM S	SNA	1
1-2-14	3	RB070	DJ64-01155B	BUTTON SWITCH; RCH-10R,SILICON,-,BLACK,SI	SNA	1
1-2-15	3		DJ61-02080A	SUPPORT BUTTON; RCH-10R,ABS,-,HB,HG-0760G	SNA	1
1-2-16	3		DJ61-02082A	BODY HAND GRIP; RCH-10R,ABS,-,EBONY BLACK	SNA	1
1-2-17	3		DJ63-01229A	COVER PCB; PB-700,ABS,EBONY BLK	SNA	1
1-2-18	3	RV005	6003-000170	SCREW-TAPTYPE; PH,+,-,B,M4,L12,ZPC(WHT),S	SNA	2
1-2-19	3		DJ61-01632A	HOLDER-HOSE C; SC8680,HDPE,NTR	SNA	1
1-2-20	3		DJ62-00271A	SEAL-HOLDER; LOIRE-PJT,PVC,LIGHT GRY	SNA	1
1-2-21	3	RA108	DJ61-01486A	CASE-HOSE; LOIRE-PJT,PP,BLK,BJ350	SNA	1
1-2-22	3	RL132	DJ67-00384A	HOSE-WIRELESS; VC-MBS810,EVA,ID36.8,OD44.	SNA	1
1-2-23	3	RL025	DJ61-01883A	BODY CLAMPER; SC9600,PP,BLK	SNA	1

No.	Lvl.	Loc.	Material Code	Description & Specification	SNA	Qty.
1-2-24	3	RB102	DJ63-01170A	COVER-CLAMPER; SC9600,PP,BLK	SNA	1
1-2-25	3	RL104	DJ64-10111G	KNOB-CLAMPER; VC-8700,ABS,-,EBONY BLACK	SNA	1
1-2-26	3	RV005	6003-000167	SCREW-TAPTYPE; PH,+,-,B,M3,L8,ZPC(BLK),SWRC	SNA	3
1-2-27	3	RA094	DJ61-70130A	SPRING ETC-CLAMPER; VC-6440,HSWR,PI0.7,ID	SNA	1
1-2-28	3		DJ63-01319A	GUARD BUMPER; RCH-11R,TPE,-,EBONY BLACK	SNA	2
1-2-29	3		DJ41-00641A	PBA-RF HANDLE; HANDLE,RAMBO,RF	SNA	1
1-3	2		DJ64-01154A	BUTTON SLIDE; RCH-11R,ABS,-,EBONY BLACK	SA	1
2	2		DJ63-01308A	COVER BATTERY; RCH-10R,ABS,-,HB,TITANIUM	SA	1
3	1		DJ97-00853C	ASSY PIPE; LOIRE,TELESCOPIC,AL,DOM,BUCKLE	SA	1
3-1	2	RP335	DJ67-00498A	CAP-KNOB; CLOVER-PJT,PC,-,-,3022R,BLACK	SNA	1
3-2	2	RA069	DJ64-00611A	KNOB-PIPE; CLOVER-PJT,ABS,HB,EBONY BLACK	SNA	1
4	1		DJ97-01999A	ASSY ACCESSORY; F700G,DUST SENSOR,BLACK,1	SA	1
4-1	2		DJ63-01032B	COVER BATTERY; F700G,ABS,-,HB,EBONY BLACK	SNA	1
4-2	2		DJ64-00920A	WINDOW LED; RAPTOR2,ABS,GRY TRP,NON-COATI	SNA	1
4-3	2		DJ63-01030B	COVER DUST SENSOR-UP; F700G,ABS,-,HB,EBON	SNA	1
4-4	2	RJ101	DJ96-00106F	ASSY SWITCH-PRESSURE; DUST-SENSOR,45mmH2O	SNA	1
4-5	2	RP457	DJ41-00535A	PBA SENSOR; VC-B835R_RAPTOR-PJT,30*71,N,D	SNA	1
4-6	2	RP335	DJ67-00498A	CAP-KNOB; CLOVER-PJT,PC,-,-,3022R,BLACK	SNA	1
4-7	2		DJ61-00584A	SPRING ETC-CAP; VC-MBM940,HSWR,CD0.7,OD7.	SNA	1
4-8	2	RA069	DJ64-00611A	KNOB-PIPE; CLOVER-PJT,ABS,HB,EBONY BLACK	SNA	1
4-9	2		DJ62-00314B	PIPE DUST SENSOR; F700G,ABS,-,EBONY BLACK	SNA	1
4-10	2	RJ161	DJ39-20275J	WIRE HARNESS-SENSOR; VC-BR836,#22,L120,#2	SNA	1
4-11	2		DJ63-01029B	COVER DUST SENSOR-LOW; F700G,ABS,-,HB,EBO	SNA	1
4-12	3	RV005	6003-000170	SCREW-TAPTYPE; PH,+,-,B,M4,L12,ZPC(WHT),S	SNA	2
4-13	2		4301-000103	BATTERY-ALKALINE; 1.5V,750mAH,LR03,10.2x4	SNA	2

3. Brush

Exploded View

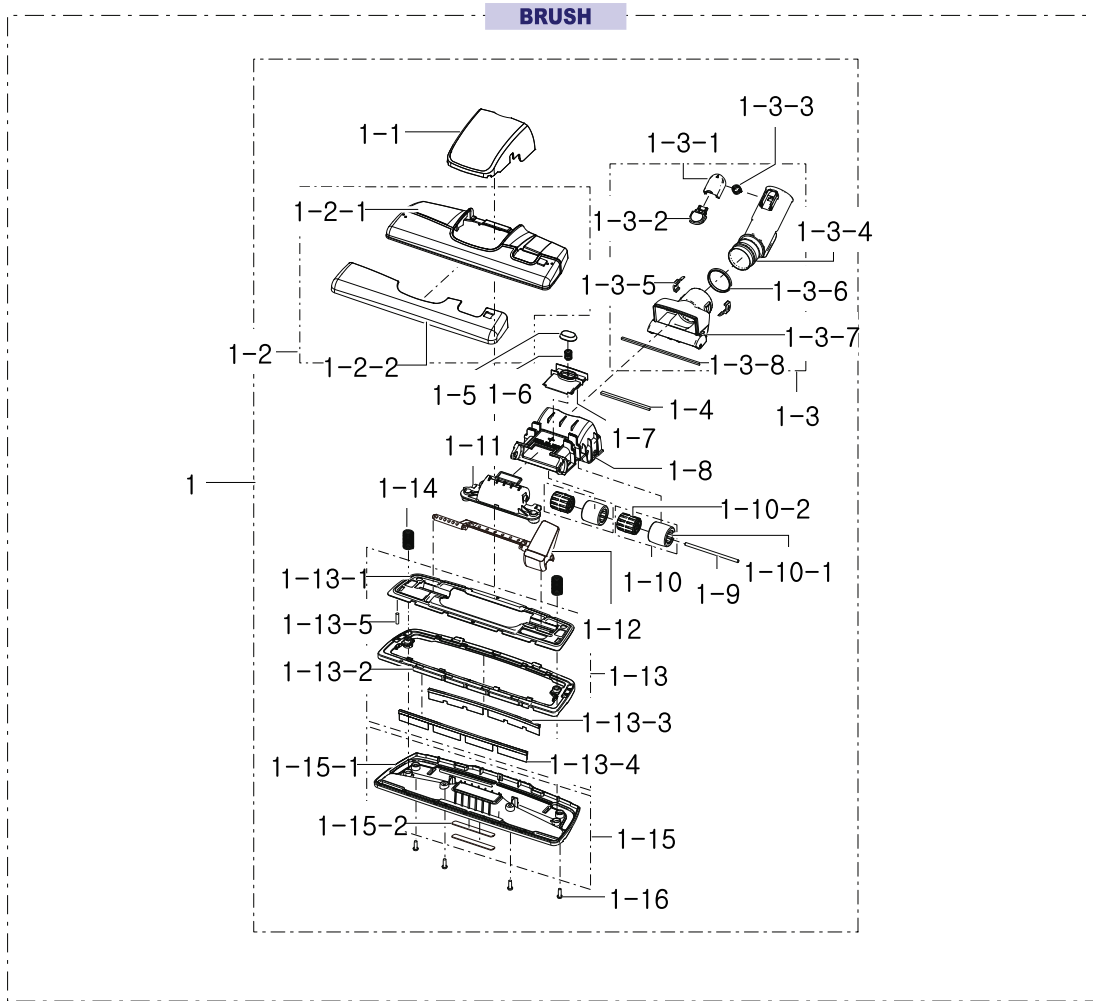

Parts List

No.	Lvl.	Loc.	Material Code	Description & Specification	SNA	Qty.
1	1		DJ97-01402A	ASSY BRUSH; -,2STEP,NB-810,BLACK,BUCKLE,E	SA	1
1-1	2	RL070	DJ63-01001A	COVER-HOLDER; NB-810,ABS,-,HB,EBONY BLACK	SNA	1
1-2	2		DJ97-01938A	ASSY COVER BRUSH; NB-810,HOT-STAMPING,INS	SNA	1
1-2-1	3		DJ63-01266A	COVER BRUSH; NB-810,ABS,-,HB,EBONY BLACK,	SNA	1
1-2-2	3		DJ63-01267A	BAND BRUSH; NB-810,TPE,EBONY BLACK,INSERT	SNA	1
1-3	2		DJ97-01406A	ASSY PIPE C/BRUSH; NB-810,BUCKLE,EBONY BL	SA	1
1-3-1	3	RP335	DJ67-00498A	CAP-KNOB; CLOVER-PJT,PC,-,3022R,BLACK	SNA	1

No.	Lvl.	Loc.	Material Code	Description & Specification	SNA	Qty.
1-3-2	3	RA069	DJ64-00611A	KNOB-PIPE; CLOVER-PJT,ABS,HB,EBONY BLACK	SNA	1
1-3-3	3		DJ61-00584A	SPRING ETC-CAP; VC-MBM940,HSWR,CD0.7,OD7.	SNA	1
1-3-4	3		DJ62-00299A	PIPE-C/BRUSH; NB-810,ABS,-,EBONY BLACK,SD	SNA	1
1-3-5	3	RL084	DJ61-20118P	GUIDE-KEY; VC-8900,ABS,DEEP GRY,TURBIN BR	SA	2
1-3-6	3		DJ62-00300A	SEAL-C/PIPE; NB-810,NBR(60),BLACK,T0.6	SNA	1
1-3-7	3		DJ61-01680A	NECK-HOLDER; NB-810,ABS,EBONY BLACK	SNA	1
1-3-8	3		DJ62-00301A	SEAL-N/HOLDER; NB-810,EVA FOAM,WHITE,T2.4	SNA	1
1-4	2		DJ62-00302A	SEAL-HOLDER; NB-810,EVA FOAM,WHITE,T3.5,W	SNA	1
1-5	2	RB193	DJ66-00580A	PISTON-DAMPER; NB-810,ABS,NATURAL	SNA	1
1-6	2	RB201	DJ61-01681A	SPRING ETC-DAMPER; NB-810,HSWR,CD0.7,ID8.	SNA	1
1-7	2	RB103	DJ63-01002A	COVER DAMPER; NB-810,ABS,-,HB,NATURAL,HG-	SNA	1
1-8	2		DJ61-01677A	GUIDE-H/AIR; NB-810,PP+TALC30%,-,HB,FC230	SNA	1
1-9	2		DJ66-00581A	SHAFT WHEEL; NB800,SUM22,L86,OD4,COATING	SNA	1
1-10	2	RP357	DJ97-01042A	ASSY WHEEL BRUSH; ASSY,SILKY-PJT,BLK,ABS+	SA	2
1-10-1	3		DJ66-00470A	WHEEL BRUSH-O; SILKY-PJT,TPS,BLK	SNA	2
1-10-2	3		DJ66-00469A	WHEEL BRUSH-I; SILKY-PJT,ABS,BLK	SNA	2
1-11	2		DJ61-01676A	GUIDE AIR; NB-810,ABS,-,HB,HG-0760GP,EBON	SNA	1
1-12	2		DJ66-00692A	LEVER BRUSH; NB-810,ABS,-,HB,HG-0760GP,EB	SNA	1
1-13	2		DJ97-01404A	ASSY BASE BRUSH; NB800,EBONY BLACK	SA	1
1-13-1	3		DJ61-01679A	BASE-FRAME; NB-810,EGI-SECC,T1.2,-,-,PRES	SNA	1
1-13-2	3		DJ61-01678A	BASE BRUSH; NB-810,ABS,-,EBONY BLACK,HB,H	SNA	1
1-13-3	3		DJ67-00586A	BRUSH NOZZLE-BACK; NB-810,URETHANE,NATURA	SNA	1
1-13-4	3		DJ67-00587A	BRUSH NOZZLE-FRONT; NB-810,URETHANE,NATUR	SNA	1
1-13-5	3		DJ67-00588A	BRUSH-NYLON; NB800,NYLON#66,BLK,STRAIGHT	SNA	1
1-14	2		DJ61-70179A	SPRING ETC-BRUSH; HSWR,PI0.9,ID13,L25,8,B	SNA	2
1-15	2		DJ97-01403A	ASSY BODY BRUSH; NB-810,RED	SA	1
1-15-1	3		DJ61-01675A	BODY BRUSH; NB-810,ABS,-,BLACK	SNA	1

Exploded Views and Parts List

No.	Lvl.	Loc.	Material Code	Description & Specification	SNA	Qty.
1-15-2	3		DJ60-00018A	SPACER-BRUSH; NB-810,WOOL,L96.3,T2,W8	SNA	2
1-16	3	RV005	6003-000170	SCREW-TAPTYPE; PH,+,-,B,M4,L12,ZPC(WHT),S	SNA	2

4. Brush2

Exploded View

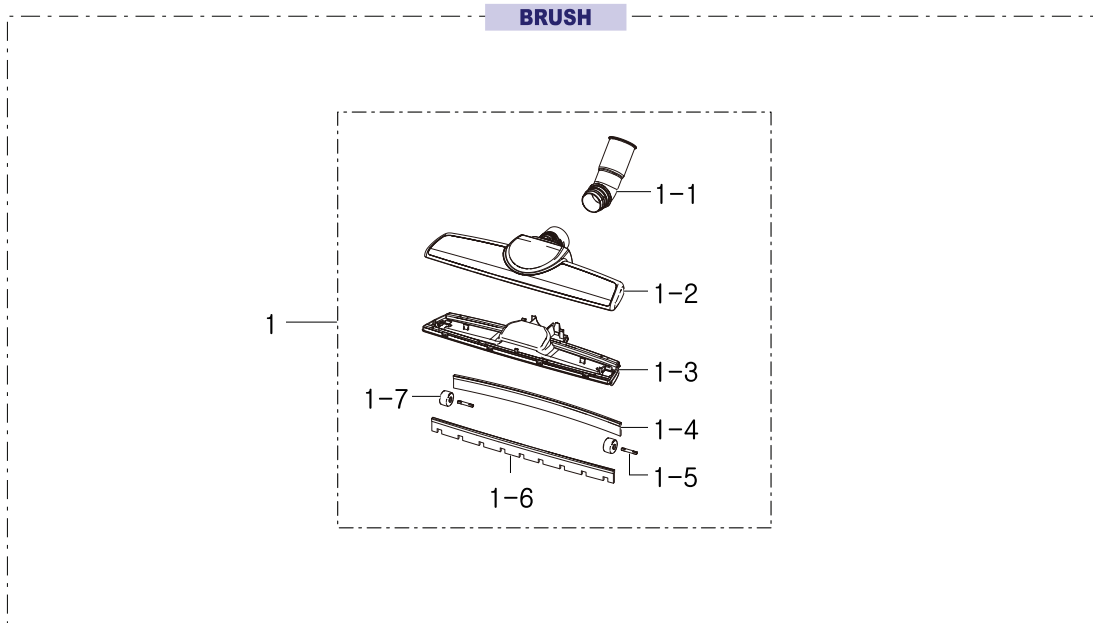

Parts List

No.	Lvl.	Loc.	Material Code	Description & Specification	SNA	Qty.
1	1	RP373	DJ97-01164A	ASSY BRUSH; PARQUET MASTER,HB-200,BLK,FRI	SA	1
1-1	2	RP379	DJ62-00274A	PIPE-C/BRUSH; PARQUET,PP,-,BLACK,BJ750	SNA	1
1-2	2	RP377	DJ63-00872A	COVER BRUSH; PARQUET,PP,-,HB,BLACK,BJ750,	SNA	1
1-3	2	RP374	DJ61-01493A	BODY BRUSH; PARQUET,PP,BLK	SNA	1
1-4	2	RP376	DJ61-01495A	HOLDER-BRUSH B; PARQUET,STAINLESS-ST301,	SNA	1
1-5	2	RP294	DJ66-00103B	SHAFT ROLLER-B; SATURN-PJT,POM,L26,OD3.9,	SNA	2
1-6	2	RP375	DJ61-01494A	HOLDER-BRUSH F; PARQUET,STAINLESS-ST301,	SNA	1
1-7	2	RP101	DJ66-70100A	ASSY ROLLER; VC550P,NEUTRAL GRY	SNA	2