

# SANYO

## SERVICE MANUAL Micro/Convection Oven

**EM5740(W)**  
(CONTINENTAL)

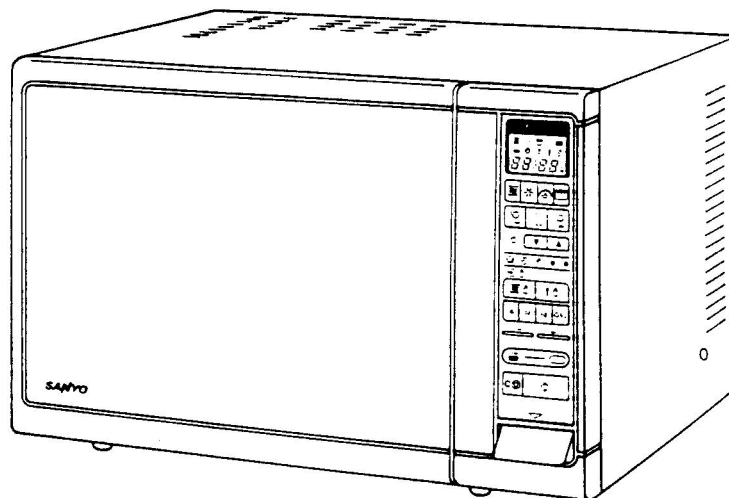

PRODUCT CODE No.	432-252-63
------------------	------------

### Foreword

Read this manual carefully, especially precaution on microwave energy, and follow the procedure strictly. Careless servicing and testing may expose yourself to the microwave energy leakage.

### PRECAUTIONS

#### PRECAUTIONS TO BE OBSERVED BEFORE AND DURING SERVICING TO AVOID POSSIBLE EXPOSURE TO EXCESSIVE MICROWAVE ENERGY

- (a) Do not operate or allow the oven to be operated with the door open.
- (b) Make the following safety checks on all ovens to be serviced before activating the magnetron or other microwave source, and make repairs as necessary:
  - (1) Interlock operation, (2) proper door closing, (3) seal and sealing surfaces (arcing, wear, and other damage), (4) damage to or loosening of hinges and latches, (5) evidence of dropping or abuse.
- (c) Before turning on microwave power for any service test or inspection within the microwave generating compartments, check the magnetron, wave guide or transmission line, and cavity for proper alignment, integrity, and connections.
- (d) Any defective or misadjusted components in the interlock, monitor, door seal, and microwave generation and transmission systems shall be repaired, replaced, or adjusted by procedures described in this manual before the oven is released to the owner.

REFERENCE NO. WM-640126

- TABLE OF CONTENTS -

Adjustment Procedures . . . . .	1	Circuit Diagram . . . . .	4
Specifications . . . . .	2	Test Procedures and Troubleshooting . . . . .	5~14
Check of Microwave Output Power . . . . .	2	Disassembly Instructions . . . . .	15~16
Precautions and Repair Service Tips . . . . .	2	Exploded View and Parts List . . . . .	17~25
Oven Control Panel . . . . .	3	Overall Circuit Diagram . . . . .	26

**CAUTION  
MICROWAVE RADIATION**

PERSONNEL SHOULD NOT BE EXPOSED TO THE MICROWAVE ENERGY WHICH MAY RADIATE FROM THE MAGNETRON OR OTHER MICROWAVE GENERATING DEVICE IF IT IS IMPROPERLY USED OR CONNECTED. ALL INPUT AND OUTPUT MICROWAVE CONNECTIONS, WAVEGUIDES, FLANGES, AND GASKETS MUST BE SECURE. NEVER OPERATE THE DEVICE WITHOUT A MICROWAVE ENERGY ABSORBING LOAD ATTACHED. NEVER LOOK INTO AN OPEN WAVEGUIDE OR ANTENNA WHILE THE DEVICE IS ENERGIZED.

**1. ADJUSTMENT PROCEDURES**

TO AVOID POSSIBLE EXPOSURE TO MICROWAVE ENERGY LEAKAGE, THE FOLLOWING ADJUSTMENT OF THE INTERLOCK SWITCHES SHOULD BE MADE ONLY BY AUTHORIZED SERVICE PERSONNEL.

**PRIMARY INTERLOCK SWITCH, SECONDARY INTERLOCK SWITCH, INTERLOCK MONITOR AND SAFETY SWITCH AND DOOR SENSING SWITCH ADJUSTMENT**

(Figure 1)

- (1) Loosen 2 screws securing the level stopper.
- (2) Adjust the lever stopper position so that it is pushed up and pull forward until there is about zero gap
  - 2-1. Between the door latch and the switch body on the door sensing switch
  - 2-2. Between the lever and the switch body on the secondary interlock switch
  - 2-3. Between the door latch and the switch body on the interlock monitor and safety switch
  - 2-4. Between the latch lever and the switch body on the primary interlock switch when the door latch is securely locked.
- (3) Tighten the lever stopper screws securely.
- (4) Make sure the terminals between "C" and "NC" of the interlock monitor and safety switch close after the primary interlock switch open when the door is opened very slowly, according to "CHECKOUT PROCEDURE FOR SWITCHES" on page 8.

- (5) Make sure the terminals between "C" and "NC" of the interlock monitor and safety switch open before the primary interlock switch close when the door is closed very slowly, according to "CHECKOUT PROCEDURE FOR SWITCHES" on page 8.
- (6) Make sure the microwave energy leakage is below the limit of the regulation ( $5 \text{ mW/cm}^2$ ) when measured with a detector. (All service adjustments must be made for minimum microwave energy leakage readings.)

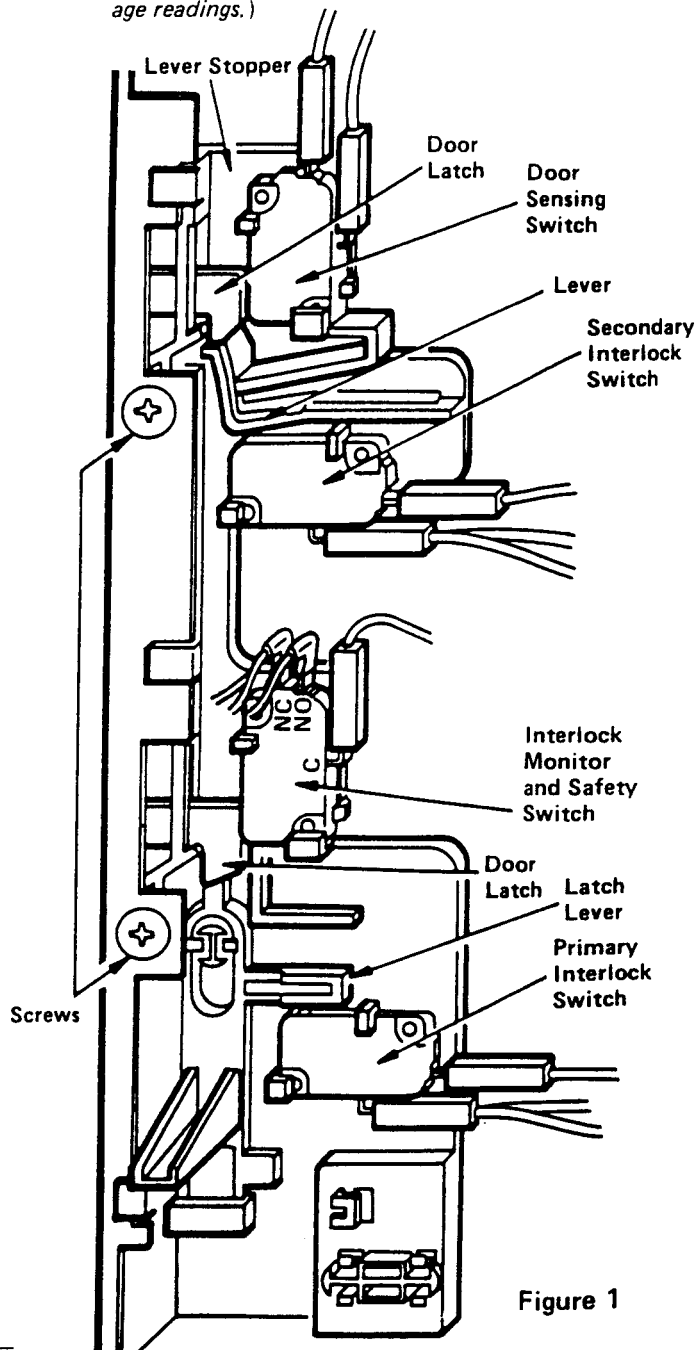

Figure 1

## 2. SPECIFICATIONS

Rated Power Consumption . . .	1,500W (For Microwave) 2,000W (For Convection) 2,000W (For Grill) 2,700W (For Dual)
Microwave Output . . . . .	800W/650W/450W/300W/ 150W/80W
Frequency . . . . .	2,450MHz±50MHz
Power Supply . . . . .	220–230V, 50Hz
Rated Current . . . . .	6.5Amp. (For Microwave) 8.5Amp. (For Convection) 8.5Amp. (For Grill) 11.5Amp. (For Dual)
Safety Devices . . . . .	Thermofuse for Magnetron, Open at 140°C Thermal Protector for Cavity, Open at 122°C Fuse 8Amp. Primary Interlock Switch Secondary Interlock Switch Safety Switch Interlock Monitor Switch
Timer . . . . .	Electronic Digital (Up to 99min. 90sec.)
Oven Temperature Control . . .	40°C ~ 250°C (For Convection) 150°C ~ 250°C (For Dual)
Overall Dimensions . . . . .	550(W)x480(D)x358(H)mm
Oven Cavity Size . . . . .	348(W)x340(D)x220(H)mm
Turn Table Diameter . . . . .	310mm
Net Weight . . . . .	Approx. 25.2Kg

## 3. CHECK OF MICROWAVE OUTPUT POWER

- (1) Prepare 1000±5g tap water.
- (2) Adjust water temperature to 10°±2°C.
- (3) Pour water into a container made of borosilicate glass, 190mm outer diameter cylinder, maximum 3mm thickness.  
Note: Use the container kept on the room temperature.
- (4) Place the container in the center of oven cavity.
- (5) Set the heating time for 53 seconds and rating full power and then start oven.
- (6) Take the container out immediately when heating time is up.
- (7) Stir water for making even water temperature in the container.
- (8) Measure water temperature.

Water temperature rise shall be 8° to 12°C.

## 4. PRECAUTIONS AND REPAIR SERVICE TI

### PRELIMINARY

A. SINCE NEARLY 4,000 VOLTS EXISTS IN SOME CIRCUITS OF THIS MICROWAVE OVEN, REPAIR SHOULD BE CARRIED OUT WITH GREAT CARE.  
B. TO AVOID POSSIBLE EXPOSURE TO MICROWAVE ENERGY LEAKAGE, THE FOLLOWING PRECAUTIONS MUST BE TAKEN BEFORE SERVICING

- (1) Before the power is applied.
  - (a) Open and close the door several times to make sure the secondary interlock switch the primary interlock switch, the interlock monitor and safety switch and the door sensing switch operate properly. (Listen for the clicking sound from the switches). Make sure the interlock monitor switch (terminal "C" and "NC") is closed after the primary interlock switch is opened when the door is opened. (See pages 1 and 8)
  - (b) Make sure the perforated screen and the dielectric choke of the door are correctly mounted.
- (2) After the power is applied:
  - (a) Open and close the door to see if the interlock mechanism operates properly.
  - (b) Check microwave energy leakage with a leakage detector and confirm the energy leakage is below 5 mW/cm<sup>2</sup>.
- (3) Do not operate the until it is completely repaired if any of the following conditions exists.
  - (a) Door does not close firmly against the cavity front.
  - (b) The hinge is broken.
  - (c) The choke dielectric or the door seal is damaged.
  - (d) The door is bent or warped, or there is any other visible damage to the oven that may cause microwave energy leakage.

NOTE: Always keep the seal clean.

- (e) Make sure that there are no defective parts in the interlock mechanism.
  - (f) Make sure that there are no defective parts in the microwave generating and transmission assembly. (especially waveguide).
- (4) The following items should be checked after the unit is repaired:
    - (a) The interlock monitor switch is connected correctly and firmly.
    - (b) The magnetron gasket on the magnetron is properly positioned.
    - (c) Waveguide and oven cavity are intact (no leakage of microwave energy).
    - (d) The door can be properly closed and the safety switches work properly.
    - (e) The oven must be stopped when the door is opened or time is up.

The oven must not be operated with any of the above components removed or bypassed.

## 5. OVEN CONTROL PANEL

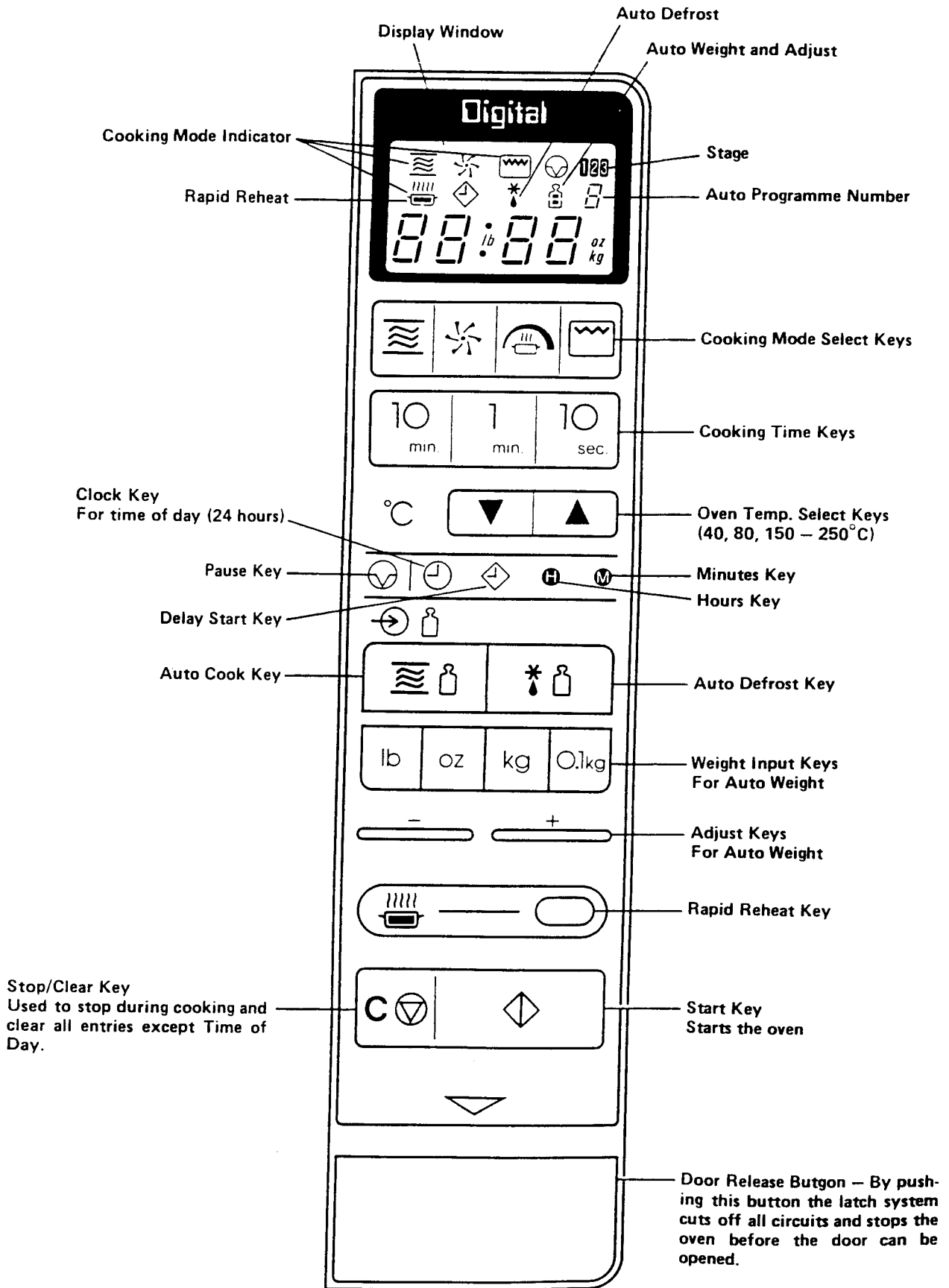

Notes: A "beep tone" sounds when a "pad" on the control panel is touched, to indicate a setting has been entered.  
When setting the controls you can keep your finger on a key until the desired setting is reached.

## 6. CIRCUIT DIAGRAM

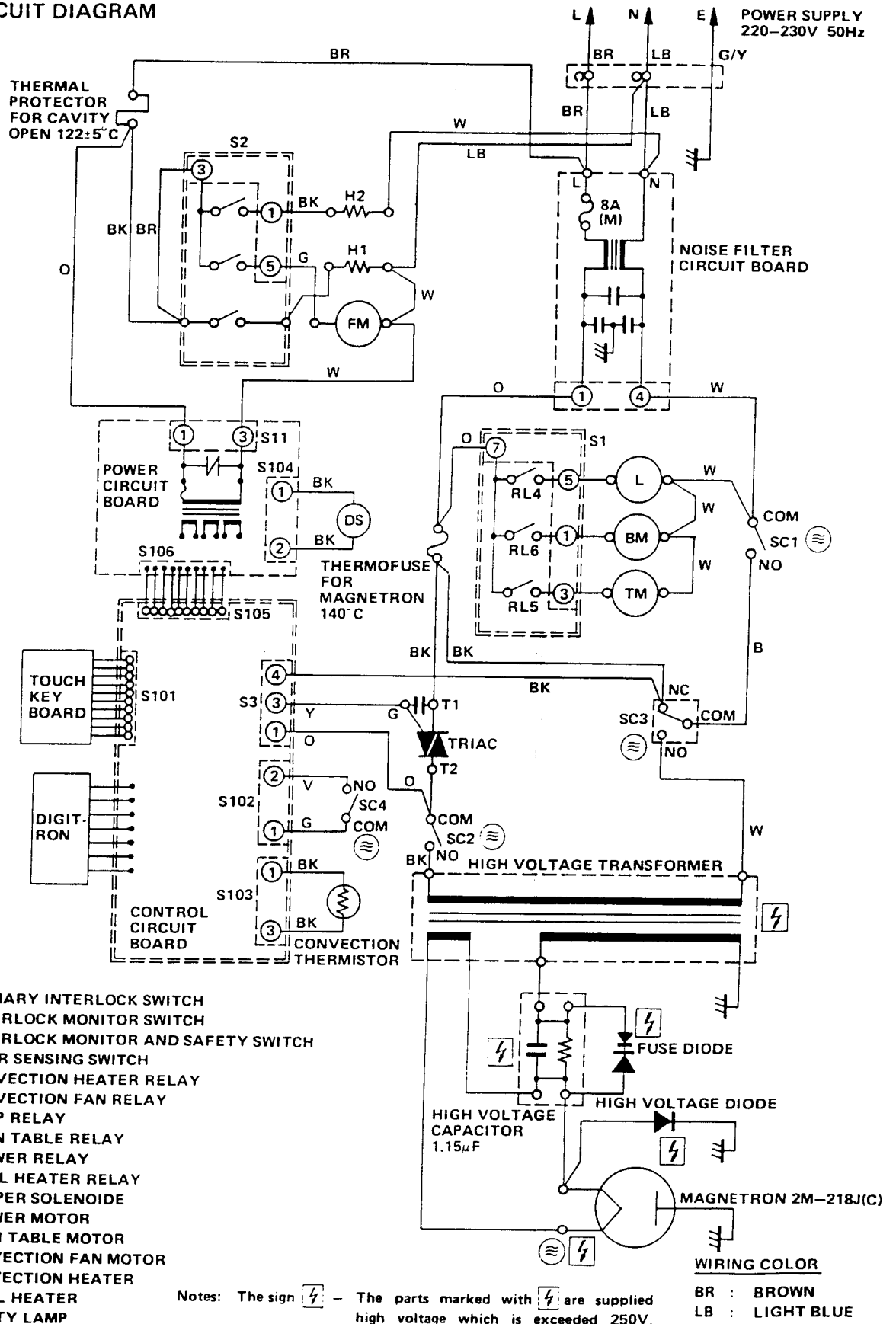

Figure 3

## 7. TEST PROCEDURES AND TROUBLESHOOTING

### CAUTION

— DISCONNECT THE POWER SUPPLY CORD FROM THE WALL OUTLET WHENEVER REMOVING THE CABINET FROM THE UNIT. PROCEED WITH THE TESTS ONLY AFTER DISCHARGING THE HIGH VOLTAGE CAPACITOR AND REMOVING THE LEAD WIRES FROM THE PRIMARY WINDING OF THE HIGH VOLTAGE TRANSFORMER. (SEE FIGURE 4)

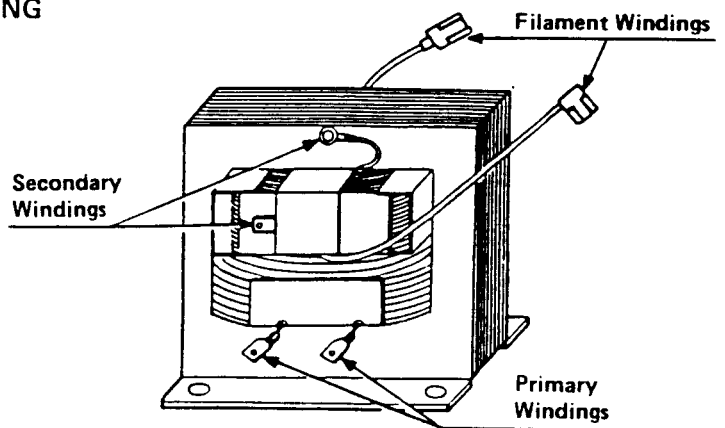
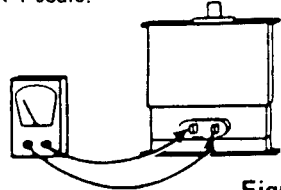
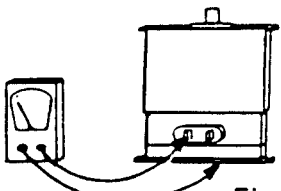
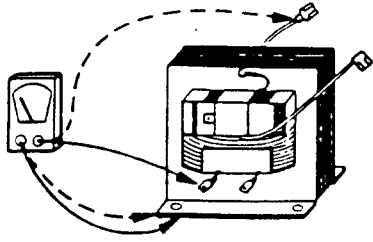
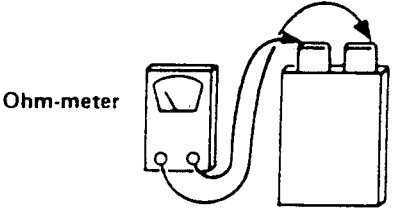
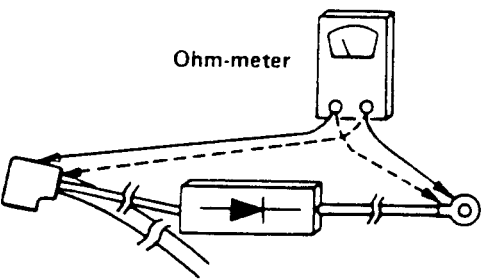
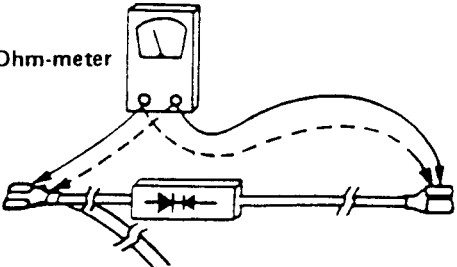
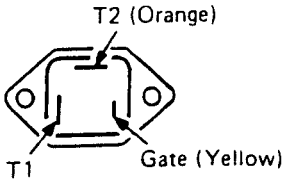

Figure 4

### A. TEST PROCEDURES

COMPONENT	CHECKOUT PROCEDURE	RESULT
MAGNETRON	<p>1) Check for resistance: Across the filament terminals of the magnetron with an ohm-meter on R x 1 scale.</p>  <p>Figure 5</p> <p>2) Check for resistance: Between each filament terminal of the magnetron and the chassis ground with an ohm-meter on highest scale.</p>  <p>Figure 6</p>	<p>Normal reading: Less than 1 ohm.</p> <p>Normal reading: Infinite ohms.</p>
HIGH-VOLTAGE TRANSFORMER	<p>1) Measure the resistance: With an ohm-meter on R x 1 scale.</p> <ol style="list-style-type: none"> <li>Primary winding;</li> <li>Filament winding;</li> <li>Secondary winding;</li> </ol> <p>2) Measure the resistance: With an ohm-meter on highest scale.</p> <ol style="list-style-type: none"> <li>Primary winding to ground;</li> <li>Filament winding to ground;</li> </ol>  <p>Figure 7</p> <p>NOTE: Remove varnish of measured point.</p>	<p>Normal readings:</p> <p>Approximately 1.18 ohms. Less than 1 ohm. Approximately 68 ohms.</p> <p>Normal readings:</p> <p>Infinite ohms. Infinite ohms.</p>

COMPONENT	CHECKOUT PROCEDURE	RESULT																
<p>HIGH-VOLTAGE CAPACITOR including BLEEDER RESISTOR</p>	<p>Measure the resistance: Across two terminals with an ohm-meter on highest scale.</p>  <p style="text-align: center;">Figure 8</p>	<p>Normal reading: Momentarily indicates several ohms, and gradually returns to 10 meg-ohms.</p> <p>Abnormal reading: Indicates continuity or 10 meg-ohms from the beginning.</p>																
<p>HIGH-VOLTAGE DIODE</p>	<p>Measure the resistance: Across two terminals with an ohm-meter on highest scale.</p>  <p style="text-align: center;">Figure 9</p>	<p>Normal reading: Indicates about the middle position in one direction (forward direction) and infinite ohms in the reverse direction, using meter which is provided with a 9-volt battery.</p> <p style="text-align: center;"><b>NOTE</b></p> <p>– Some digital meter may show over even in a forward direction because low measuring voltage of meter does not allow the meter current to pass through the high voltage diode.</p> <p>Abnormal reading: Indicates continuity or infinite ohms in both directions.</p>																
<p>FUSE DIODE</p>	<p>Measure the resistance: Across two terminals with an ohm-meter on highest scale.</p>  <p style="text-align: center;">Figure 10</p>	<p>Normal reading: Indicates infinite ohms in both directions.</p> <p>Abnormal reading: Indicates continuity in both directions or continuity in one direction and infinite ohms in reversed direction.</p>																
<p>POWER CIRCUIT BOARD</p>	<p>Measure the voltage: Between test points TP-1, TP-3, TP-4, TP-5 or TP-6 and ground on the power circuit board while connecting with control circuit board. (See power circuit board on page 25)</p>	<table border="1" style="margin-left: auto; margin-right: auto;"> <tr> <td>Test Point</td> <td>TP-1</td> <td>TP-3</td> <td>TP-4</td> </tr> <tr> <td>Voltage</td> <td>+0.7V DC</td> <td>-5V DC</td> <td>-12V DC</td> </tr> <tr> <td></td> <td>TP-5</td> <td>TP-6</td> <td></td> </tr> <tr> <td></td> <td>-20V DC</td> <td>-30V DC</td> <td></td> </tr> </table>	Test Point	TP-1	TP-3	TP-4	Voltage	+0.7V DC	-5V DC	-12V DC		TP-5	TP-6			-20V DC	-30V DC	
Test Point	TP-1	TP-3	TP-4															
Voltage	+0.7V DC	-5V DC	-12V DC															
	TP-5	TP-6																
	-20V DC	-30V DC																

COMPONENT	CHECKOUT PROCEDURE	RESULT																
CONTROL CIRCUIT BOARD	Measure the voltage: Between test points TP-1, TP-2, TP-3, TP-4 or TP-6 and ground or between TP-7 and TP-8 on the control circuit board while connecting with power circuit board. (See control circuit board on page 23)	<table border="1"> <thead> <tr> <th data-bbox="958 282 1157 340">Test Point</th> <th data-bbox="1161 282 1255 340">TP-1</th> <th data-bbox="1260 282 1354 340">TP-2</th> <th data-bbox="1359 282 1433 340">TP-3</th> </tr> </thead> <tbody> <tr> <td data-bbox="958 347 1157 405">Voltage</td> <td data-bbox="1161 347 1255 405">+0.7V DC</td> <td data-bbox="1260 347 1354 405">-3V DC</td> <td data-bbox="1359 347 1433 405">-5V DC</td> </tr> <tr> <td></td> <td data-bbox="1161 412 1255 470">TP-4</td> <td data-bbox="1260 412 1354 470">TP-6</td> <td data-bbox="1359 412 1433 470">TP-7/ TP-8</td> </tr> <tr> <td></td> <td data-bbox="1161 477 1255 535">-12V DC</td> <td data-bbox="1260 477 1354 535">-30V DC</td> <td data-bbox="1359 477 1433 535">2.9V AC</td> </tr> </tbody> </table>	Test Point	TP-1	TP-2	TP-3	Voltage	+0.7V DC	-3V DC	-5V DC		TP-4	TP-6	TP-7/ TP-8		-12V DC	-30V DC	2.9V AC
Test Point	TP-1	TP-2	TP-3															
Voltage	+0.7V DC	-3V DC	-5V DC															
	TP-4	TP-6	TP-7/ TP-8															
	-12V DC	-30V DC	2.9V AC															
THERMISTOR	Measure the resistance: Between the Pin 1 and Pin 3 of connector S103 after disconnecting it from the control circuit board with an ohm-meter on highest scale.	Normal reading: Approximately 300K ohms.																
DAMPER SOLENOID	Measure the resistance: Between the pins of connector S104 after disconnecting it from the power circuit board with an ohm-meter on R x 1 scale.	Normal reading: Approximately 50 ohms.																
CONVECTION HEATER (BACK HEATER)	Measure the resistance: After removing the lead wires from the convection heater with an ohm-meter on R x 1 scale.	Normal reading: Approximately 41 ohms.																
GRILL HEATER (UPPER HEATER)	Measure the resistance: After removing the lead wires from the grill heater with an ohm-meter on R x 1 scale.	Normal reading: Approximately 71 ohms.																
BLOWER MOTOR	Measure the resistance: After removing the lead wires from the blower motor with an ohm-meter on R x 100 scale.	Normal reading: Approximately 269 ohms.																
CONVECTION FAN MOTOR	Measure the resistance: After removing the lead wires from the convection fan motor with an ohm-meter on R x 100 scale.	Normal reading: Approximately 105 ohms.																
TURN TABLE MOTOR	Measure the resistance: After removing the lead wires from the turn table motor with an ohm-meter on highest scale.	Normal reading: Approximately 22K ohms.																
TRIAC	Measure each resistance: Between the terminals of the triac. Use the R x 1 scale on an ohm-meter. <div style="text-align: center;">  <p>(Black) T1      Gate (Yellow)      T2 (Orange)</p> </div>	Normal readings: Gate to T1: About 20 ohms. Gate to T2: Infinite ohms. T1 to T2: Infinite ohms. <p style="text-align: center;"><b>NOTE</b></p> - When the triac is replaced, be sure to check that each lead wire is securely connected to the terminals on the triac.																



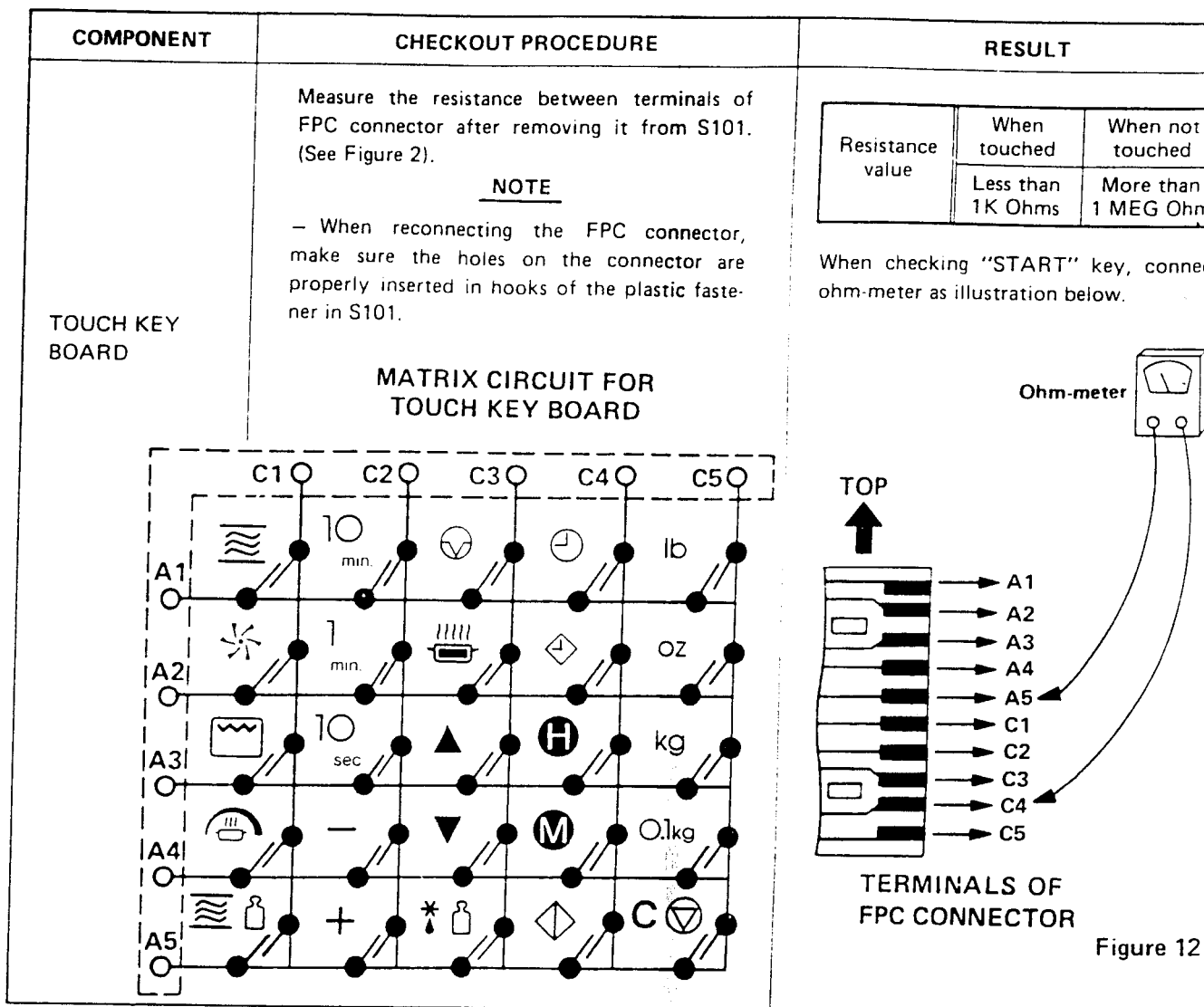

Figure 12

**CHECKOUT PROCEDURE FOR SWITCHES**

Disconnect the lead wires from the switches and check for the continuity of the switches connecting an ohm-meter to its terminals.

SWITCHES (See Figure 1 on page 1)	CHECKOUT PROCEDURES	DOOR OPEN	DOOR CLOSED
Primary Interlock	Terminals "COM" and "NO"		
Secondary Interlock			
Door Sensing			
*Safety			
*Interlock Monitor	Terminals "COM" and "NC"		

NOTE: \*Interlock Monitor Switch and Safety Switch are installed in a single case. (See Page 1)

**CAUTION:** After checking the switches, make sure that the interlock monitor switch is properly connected according to the CIRCUIT DIAGRAM on page 4.

STEP

SEQUENCE

RESULT

**(2) PROBLEM**  
Cooking operation will not start

**CHECK:** 1. Fuse BA (If fuse is blow. See "C. REMOVING FUSE" on page 15.)

2. Primary and Secondary Interlock Switches
3. Interlock Monitor and Safety Switch (Terminals "C" and "NO")
4. Thermofuse for Magnetron
5. Touch Key Board (Start Key Function)

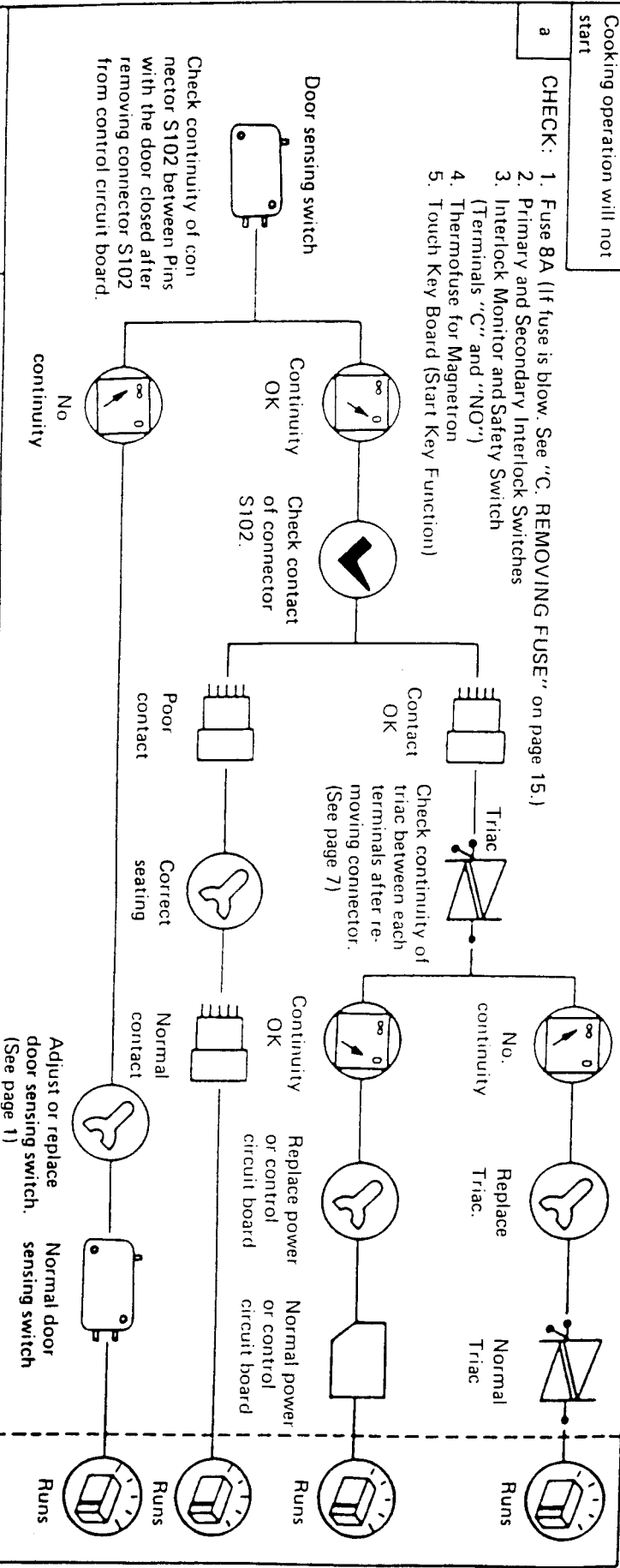

**(3) PROBLEM**  
Oven does not heat up.

a

**PROBLEM**  
3-b

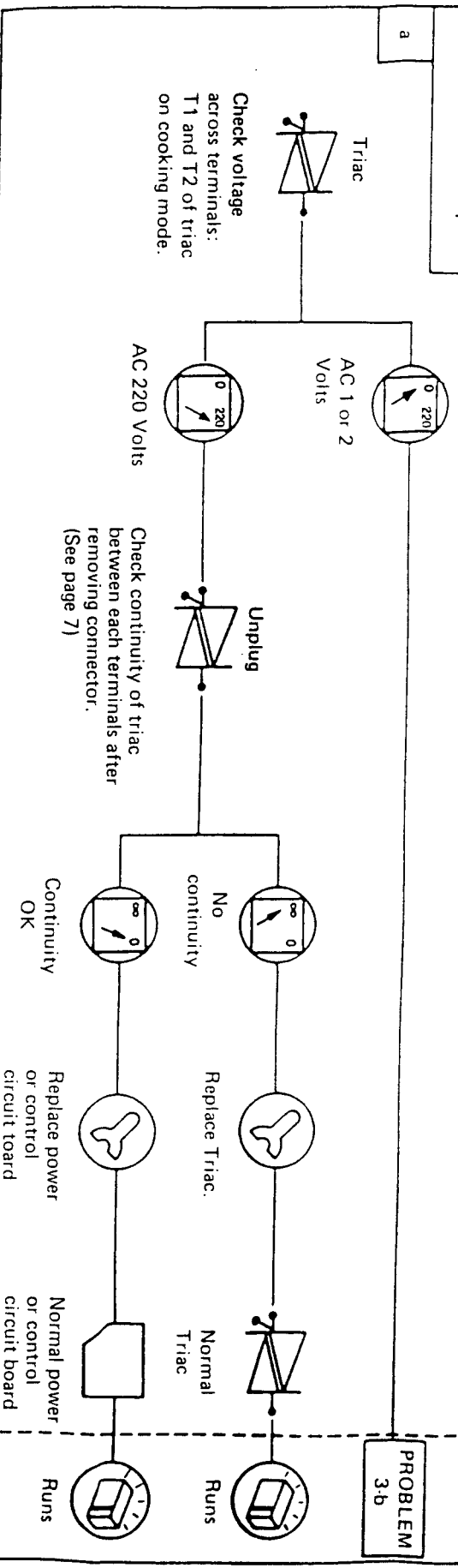

# B. TROUBLESHOOTING

## (A) Troubles in microwave cooking

### SEQUENCE

### RESULT

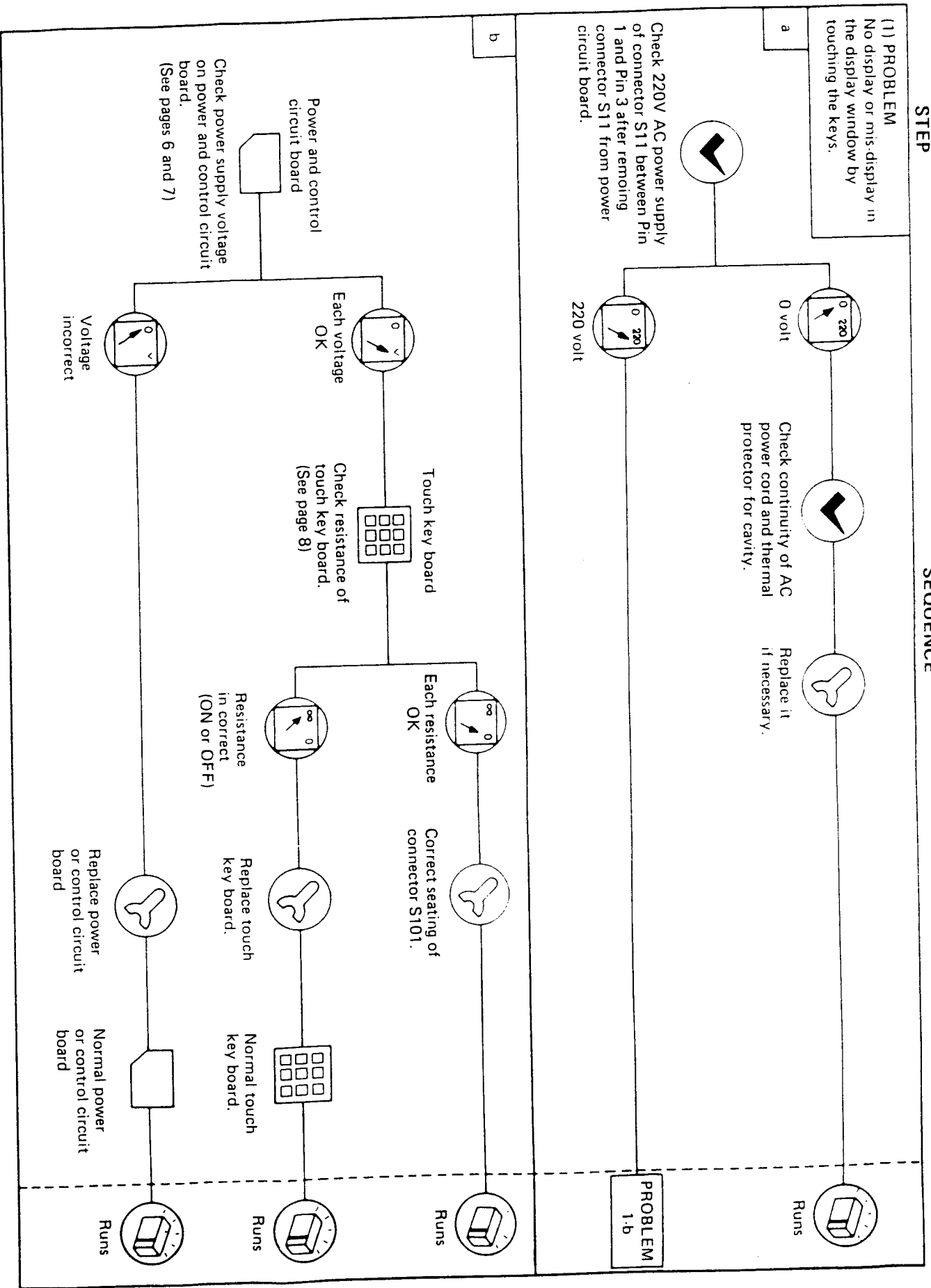

STEP

SEQUENCE

RESULT

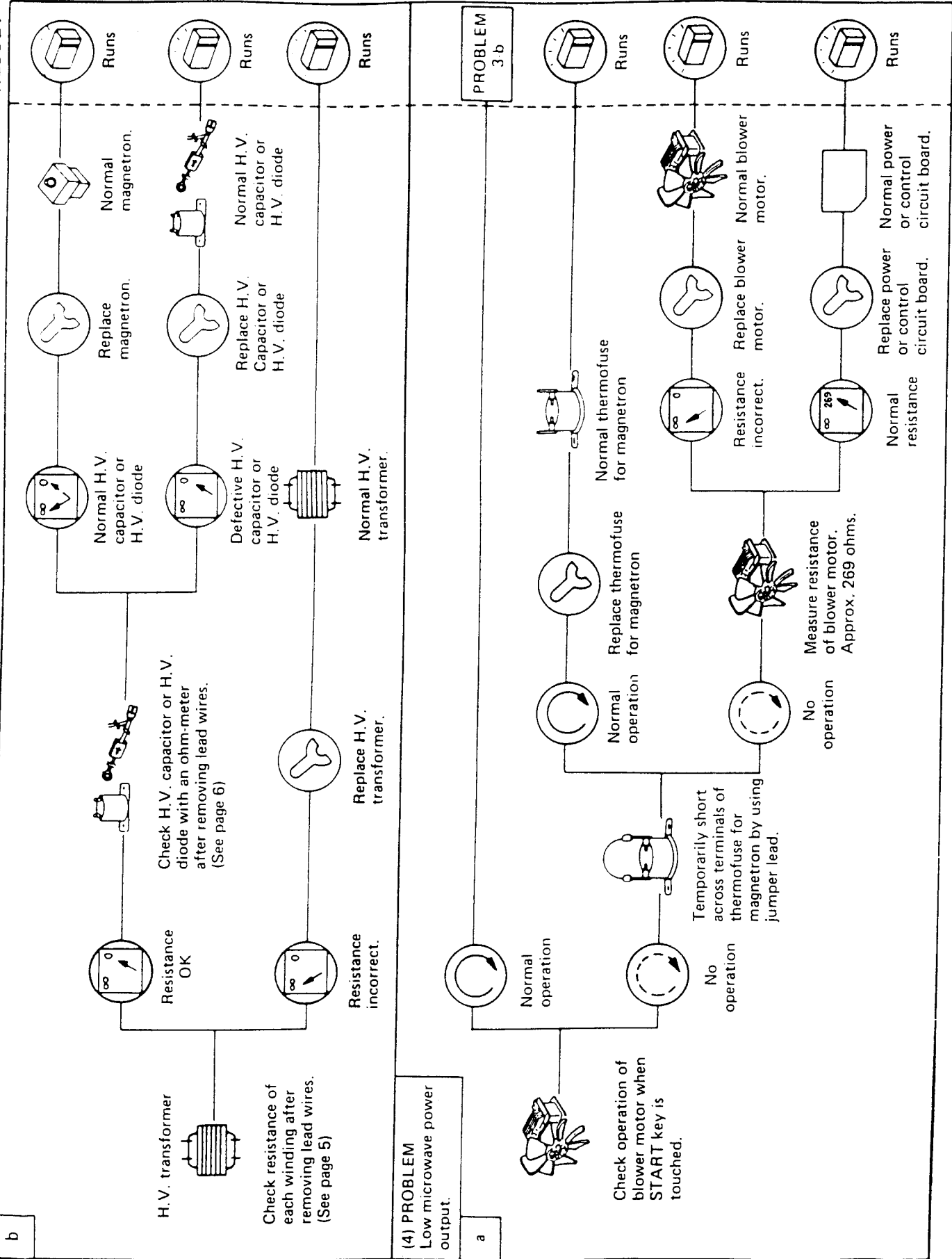

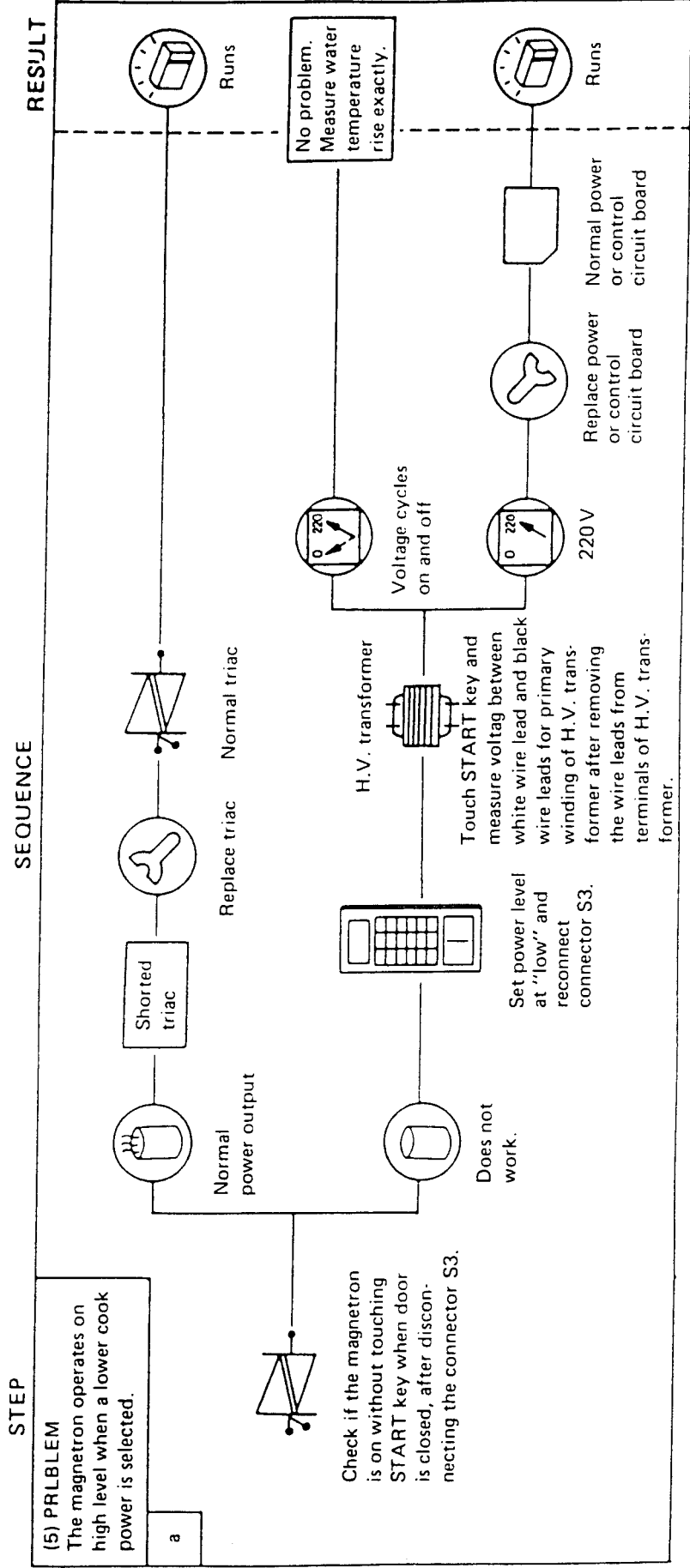

(b) Troubles in convection/grill cooking

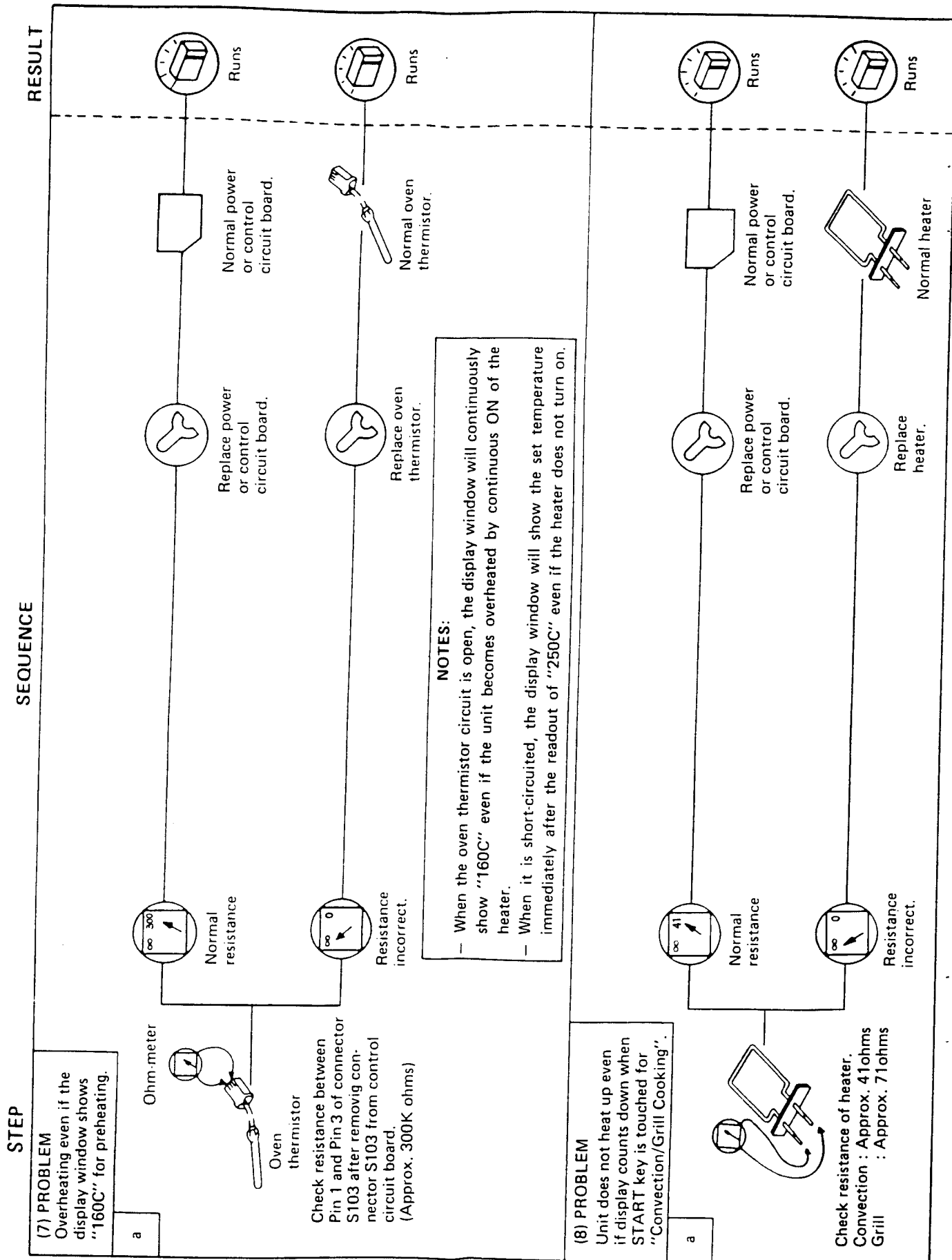

STEP

SEQUENCE

RESULT

(9) PROBLEM  
Unit operation seems to be normal but little or no heating is produced for "Convection Cooking".

a CHECK: Damper

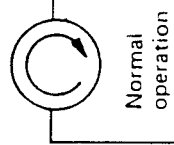

Check operation of convection fan when START key is touched.

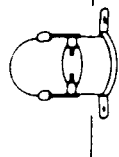

No operation

Temporarily short across terminals of thermal protector for cavity by using jumper lead.

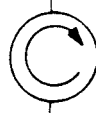

Replace thermal protector for cavity.

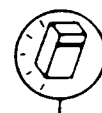
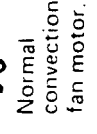

Measure resistance of convection fan motor.  
Approx. 105 ohms.

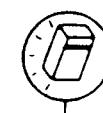
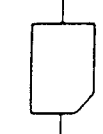
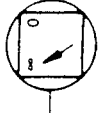

PROBLEM 8-a

## 8. DISASSEMBLY INSTRUCTIONS

- OVEN MUST BE DISCONNECTED FROM ELECTRICAL OUTLET WHEN MAKING REPLACEMENTS, REPAIRS, ADJUSTMENTS AND CONTINUITY CHECKS BEFORE PROCEEDING WITH ANY REPAIR WORK AFTER DISCONNECTING. WAIT AT LEAST 1 MINUTE, UNTIL THE CAPACITOR IN THE HIGH-VOLTAGE AREA HAS FULLY DISCHARGED.
- WHEN REPLACING ANY DOOR MICROSWITCH, REPLACE WITH THE SAME TYPE SWITCH SPECIFIED ON THE PARTS LIST.

### A REMOVING PRIMARY INTERLOCK SWITCH, SECONDARY INTERLOCK SWITCH, INTERLOCK MONITOR AND SAFETY SWITCH AND DOOR SENSING SWITCH

(See Figure 1 on page 1 and Figure 13 on this page)

- (1) Remove 2 screws securing the lever stopper.
- (2) Disconnect all lead wires from the primary interlock switch, the secondary interlock switch, the interlock monitor and safety switch and the door sensing switch.
- (3) Rotate counterclockwise the primary interlock switch while pressing the switch stopper of the lever stopper.  
Then, remove the primary interlock switch.
- (4) Remove the secondary interlock switch by reference to the step (3).
- (5) Remove the interlock monitor and safety switch by reference to the step (3).
- (6) Remove the door sensing switch by reference to the step (3).
- (7) Make necessary adjustment, and make microwave energy leakage check according to "1. ADJUSTMENT PROCEDURES" on page 1, after it is replaced with new one, and check proper operation of it according to "CHECKOUT PROCEDURE FOR SWITCHES" on page 8.

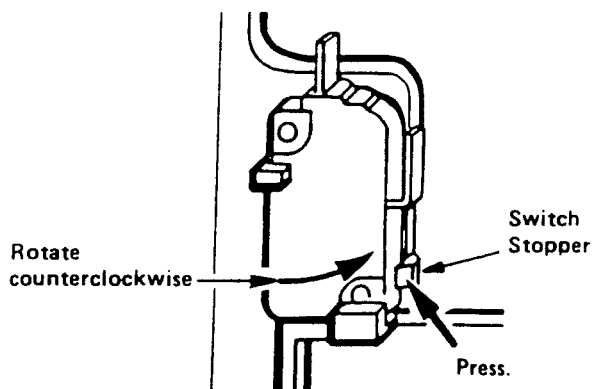

Figure 13

Interlock Switch Replacement—when replacing faulty switches, be sure switch mounting tabs are not bent, broken or otherwise deficient in their ability to secure the switches in place.

### B. REMOVING MAGNETRON

- (1) Remove 2 screws securing the thermofuse.
- (2) Disconnect all lead wires from the magnetron.
- (3) Remove 1 screw securing the lead wire ass'y (with diode) to the magnetron.
- (4) Remove 1 screw securing the duct to the magnetron.
- (5) Remove 4 hex nuts securing the magnetron to the waveguide.
- (6) Take out magnetron VERY CAREFULLY.

#### NOTES

- When removing the magnetron, make sure that its dome does not hit any adjacent parts, or it may be damaged.
- When replacing the magnetron, be sure to install the magnetron gasket in the correct position and be sure that the gasket is in good condition.
- After replacing the magnetron, be sure to check the microwave energy leakage with a leakage detector and confirm the leakage is below 5 mW/cm<sup>2</sup>.

### C. REMOVING FUSE

Remove the 8A fuse with a screwdriver.

#### NOTES

- When replacing the 8A fuse, be sure to use an exact repair part.
- If the 8A fuse blows immediately, check the primary interlock switch and the interlock monitor switch (terminals "C" and "NC") according to "CHECKOUT PROCEDURE FOR SWITCHES" on page 8, and make sure to check the microwave energy leakage according to "1. ADJUSTMENT PROCEDURE" on page 1, when the primary interlock switch or the interlock monitor and safety switch is repaired and replaced.
- If the primary interlock switch is defective, replace not only the primary interlock switch but also the interlock monitor and safety switch. Then install a new 8A fuse.
- If the primary interlock switch and the interlock monitor switch (terminals "C" and "NC") operate properly, determine which of the following is defective: control circuit board, power circuit board, blower motor, convection fan motor, turn table motor, high voltage transformer, high voltage capacitor, high voltage diode or magnetron.
- If the high voltage diode is defective, replace not only the high voltage diode but also the fuse diode.



#### **D. REMOVING REAR COVER**

- (1) Disconnect 3 lead wires from the terminals in the cord bushing.
- (2) Disconnect 3 lead wires from the blower motor.
- (3) Remove 2 screws securing the rear cover to the bottom plate.

#### **E. REMOVING CONVECTION HEATER COMPLETE (WITH CONVECTION FAN MOTOR)**

(See exploded view on page 18)

- (1) Remove 6 screws securing the convection heater complete from inside of the oven cavity.
- (2) Disconnect all lead wires from the convection fan motor, the convection heater and the cavity thermal protector.
- (3) Remove 7 screws securing the convection heater complete from backside of the unit.

#### **F. REMOVING DOOR**

- (1) Remove 2 bolts securing the upper hinge.
- (2) Tilt the top of the door toward you.
- (3) Lift up the door to remove it.

#### **NOTES**

- After replacing the door, be sure to check that the primary interlock switch, the secondary interlock switch, the interlock monitor and safety switch and the door sensing switch operate normally. (See page 1)
- After replacing the door, check for microwave energy leakage with a leakage detector. Microwave energy leakage must be below the limit of 5 mW/cm<sup>2</sup>.

#### **G. DISASSEMBLYING DOOR**

(See exploded view on page 21)

- (1) Insert a thin flat-blade screwdriver between the dielectric choke and the door main frame and lift up the dielectric choke to release hooks one by one.
- (2) Remove 6 screws securing the door cover to the door main frame.

#### **NOTES**

- The dielectric choke may be damaged when it is removed.  
When reinstalling the choke dielectric, change the dielectric choke if it is damaged.
- After installing the door in the place, check for microwave energy leakage with a leakage detector. Microwave energy leakage must be below the limit of 5 mW/cm<sup>2</sup>.

9. EXPLODED VIEW AND PARTS LIST  
CAVITY PARTS-A

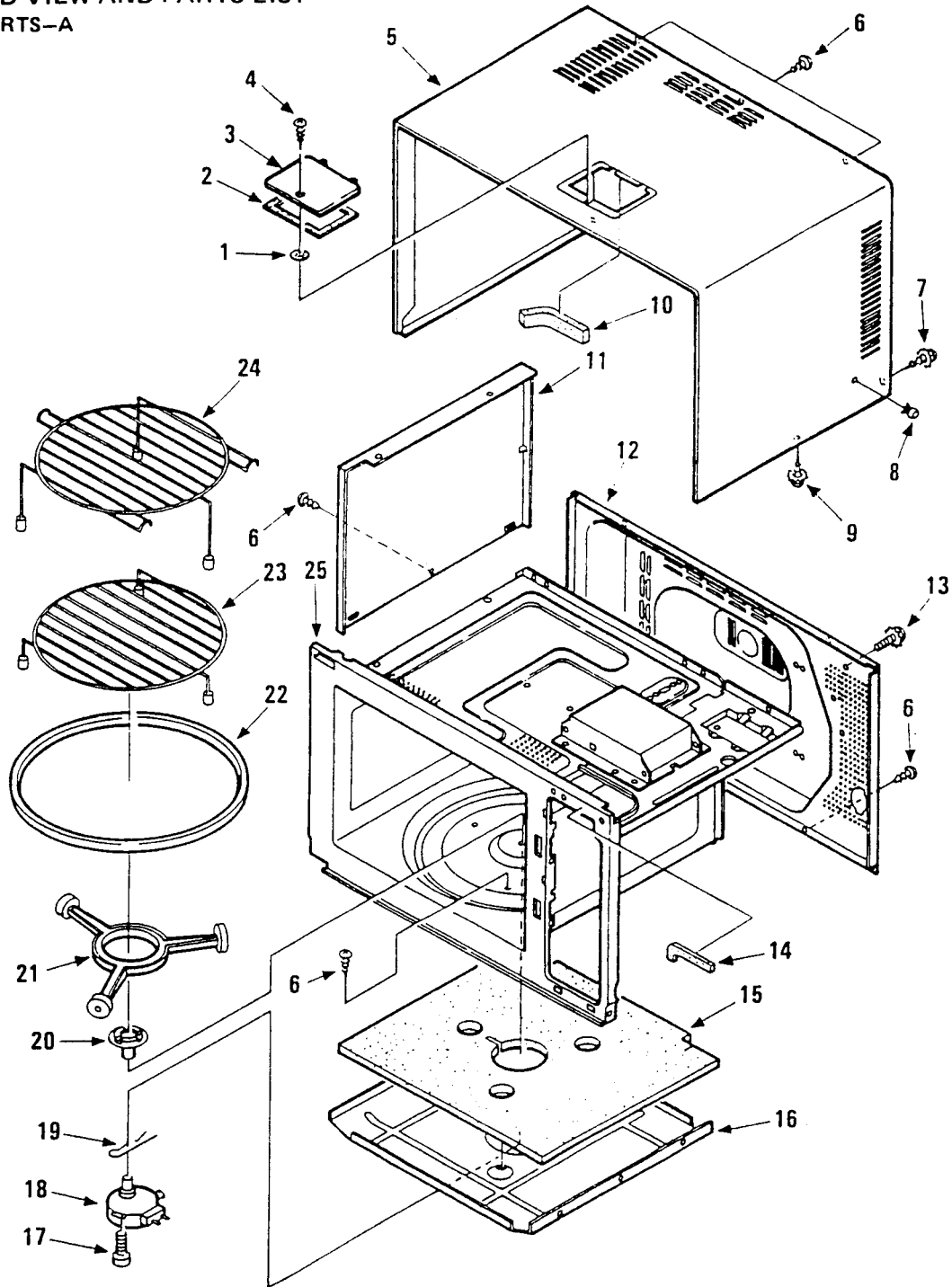

Key No.	Part No.	Description	Q'ty
1	412 018 4008	NUT HEX+CON-SW 3 U	1
2	617 065 8812	Cabinet Cover Gasket	1
3	617 065 8294	Cabinet Cover	1
4	411 075 5300	SCR TPG OVL 3x8 C2	1
5	617 115 9837	Cabinet	1
6	411 006 9902	SCR TPG TRS 4x10 Z1	8
7	411 110 2608	SCR E-TPG TRS+TW 4x12 Z1	2
8	617 064 7519	Clip	1
9	617 104 9763	Special Screw	1
10	617 121 6097	Packing	1
11	617 111 7851	External Cover, Left	1
12	617 128 0067	Rear Cover	1
13	412 024 9400	SCR EVR PAN 4x12 Z1	1

Key No.	Part No.	Description	Q'ty
14	617 106 2564	Packing	1
15	617 111 7875	Heat Insulator	1
16	617 111 7820	External Cover, Bottom	1
17	412 021 9106	SCR EVR PAN 4x10 Z1	2
18	617 111 7691	Gear Motor	1
19	617 080 6787	Stopper Pin	1
20	617 130 7184	Turn Table Shaft	1
21	617 111 8216	Roller	1
22	617 122 8724	Rotating Tray	1
23	617 115 7277	Grill Net, Low Legs	1
24	617 111 8315	Grill Net, High Legs	1
25	617 123 4749	Oven Cavity (Not Service Part)	1

CAVITY PARTS-B

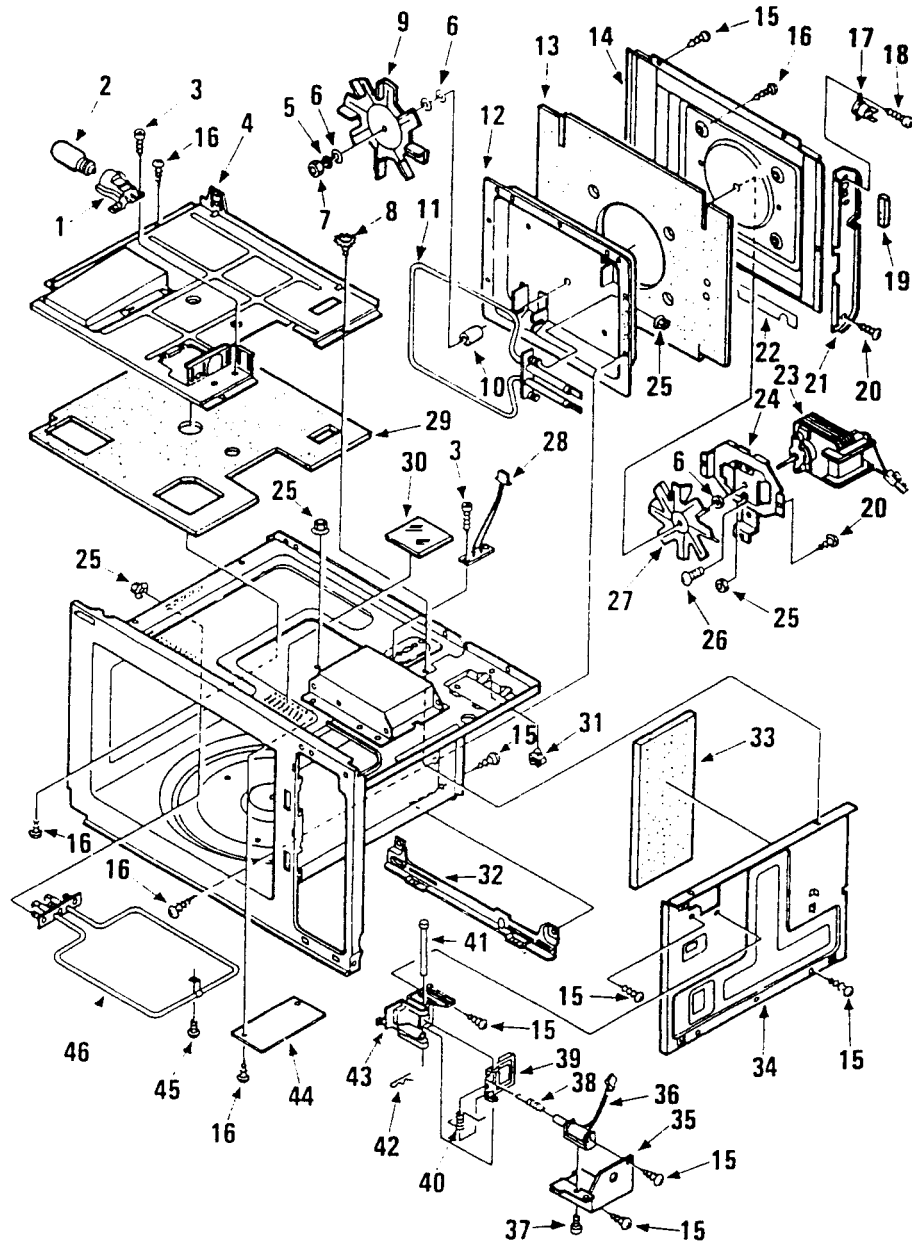

Key No.	Part No.	Description	Q'ty
1	617 077 6356	Lamp Socket	1
2	617 005 5659	Lamp, 240V 25W	1
3	411 064 6608	SCR TPG BIN 3x8 Z1	3
4	617 111 7783	External Cover, Top	1
5	411 086 7508	WASHER SPR 5 U	1
6	617 080 5568	Special Washer	4
7	411 055 0202	HUT HEX 5 U	1
8	411 110 2608	SCR E-TPG TRS+TW 4x12 Z1	2
9	617 075 1162	Convection Fan	1
10	617 107 3171	Collar	1
11	617 118 4259	Heater, Convection	1
12	617 111 7738	Heater Case	1
13	617 111 8339	Heat Insulator	1
14	617 112 3166	External Cover, Rear	1
15	411 006 9902	SCR TPG TRS 4x10 Z1	16
16	411 074 5301	SCR TPG TRS 4x10 U	15
17	617 117 5851	Thermostat, Cavity, 122°C	1
18	411 007 6900	SCR TPG PAN 3x6 Z1	1
19	617 121 6110	Packing	1
20	411 065 2500	SCR TPG BIN 4x6 Z1	5
21	617 112 3173	Space Partition	1
22	617 116 0598	Packing	1
23	617 118 4273	Motor, Convection	1

Key No.	Part No.	Description	Q'ty
24	617 075 1476	Fan Base	1
25	411 053 9306	NUT HEX+FLG W/SRT 4 Z1	8
26	412 021 9106	SCR EVR PAN 4x10 Z1	1
27	617 075 1186	Motor Fan	1
28	617 111 8124	Thermistor Ass'y	1
29	617 111 7868	Heat Insulator, Top	1
30	617 111 7677	Light Opening Cover	1
31	617 080 6152	Wire Clip	1
32	617 111 7486	Bottom Plate Bracket	1
33	617 111 7882	Heat Insulator, Right	1
34	617 111 7844	External Cover, Right	1
35	617 111 7912	Duct, Magnetron	1
36	617 111 7981	Solenoid	1
37	411 002 8503	SCR PAN 3x6 Z1	2
38	617 111 7974	Spring, Solenoid	1
39	617 111 7936	Dumper	1
40	617 111 7967	Spring, Dumper	1
41	617 111 7950	Shaft	1
42	617 080 6626	Stopper Pin	1
43	617 111 7905	Duct, Dumper	1
44	617 111 7660	Cavity Cover	1
45	411 051 1906	SCR TRS 4x6 U	1
46	617 118 4280	Heater, Grill	1

# SWITCHES AND MICROWAVE PARTS

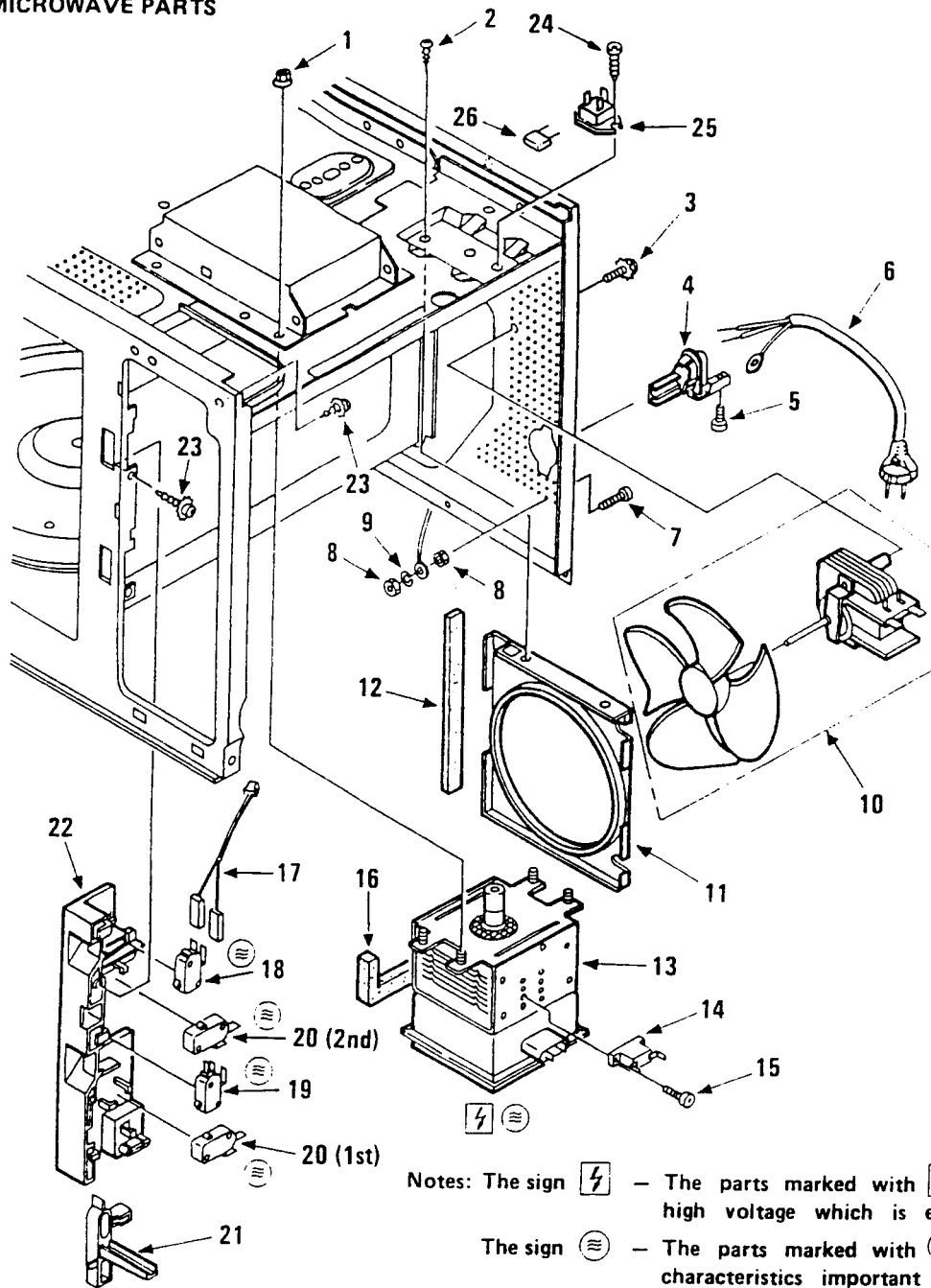



Notes: The sign ⚡ — The parts marked with ⚡ are supplied high voltage which is exceeded 250V.  
 The sign ⊕ — The parts marked with ⊕ have special characteristics important for microwave leakage. When replacing any of these parts use only manufacturer's specified parts.

Key No.	Part No.	Description	Q'ty
1	411 004 3506	NUT HEX+FLG W/SRT 5 Z1	4
2	411 006 9902	SCR TPG TRS 4x10 Z1	2
3	411 130 4200	SCR E-TPG TRS+TW 4x8 Z1	2
4	617 115 7260	Cord Bushing	1
5	617 121 6103	Special Screw	1
6	617 128 0074	Power Cord, European Type Plug (S2)	1
7	411 010 5907	SCR EVR PAN 4x12 C2	1
8	411 004 4503	NUT HEX 4 N1	2
9	411 008 1508	WASHER SPR 4 N1	1
10	617 119 4777	Blower Complete	1
	617 111 8148	Motor	
	617 112 1025	Fan	
11	617 104 4997	Fan Motor Base	1
12	617 075 5573	Packing	1
13	415 001 8304	MAGNETRON 2M218J(T)Z	1

Key No.	Part No.	Description	Q'ty
14	617 002 1913	Thermofuse, 140°C	1
15	411 007 6900	SCR TPG PAN 3x6 Z1	2
16	617 073 6855	Packing	1
17	617 104 7721	Harness	1
18	617 004 5827	Micro Switch, Door Sensing, V-5230DK-084	1
19	617 118 9247	Micro Switch, Interlock Monitor, V-5110D-118	1
20	617 004 5773	Micro Switch, 1st and 2nd Interlock, V-5230D-082	2
21	617 101 0275	Latch Lever	1
22	617 101 0268	Lever Stopper	1
23	411 110 2608	SCR E-TPG TRS+TW 4x12 Z1	2
24	411 006 3207	SCR TPG BIN 4x8 Z1	2
25	407 111 7100	THYRISTOR TG25C60	1
26	403 057 3701	POLYESTER 0.1μ K 50V	1

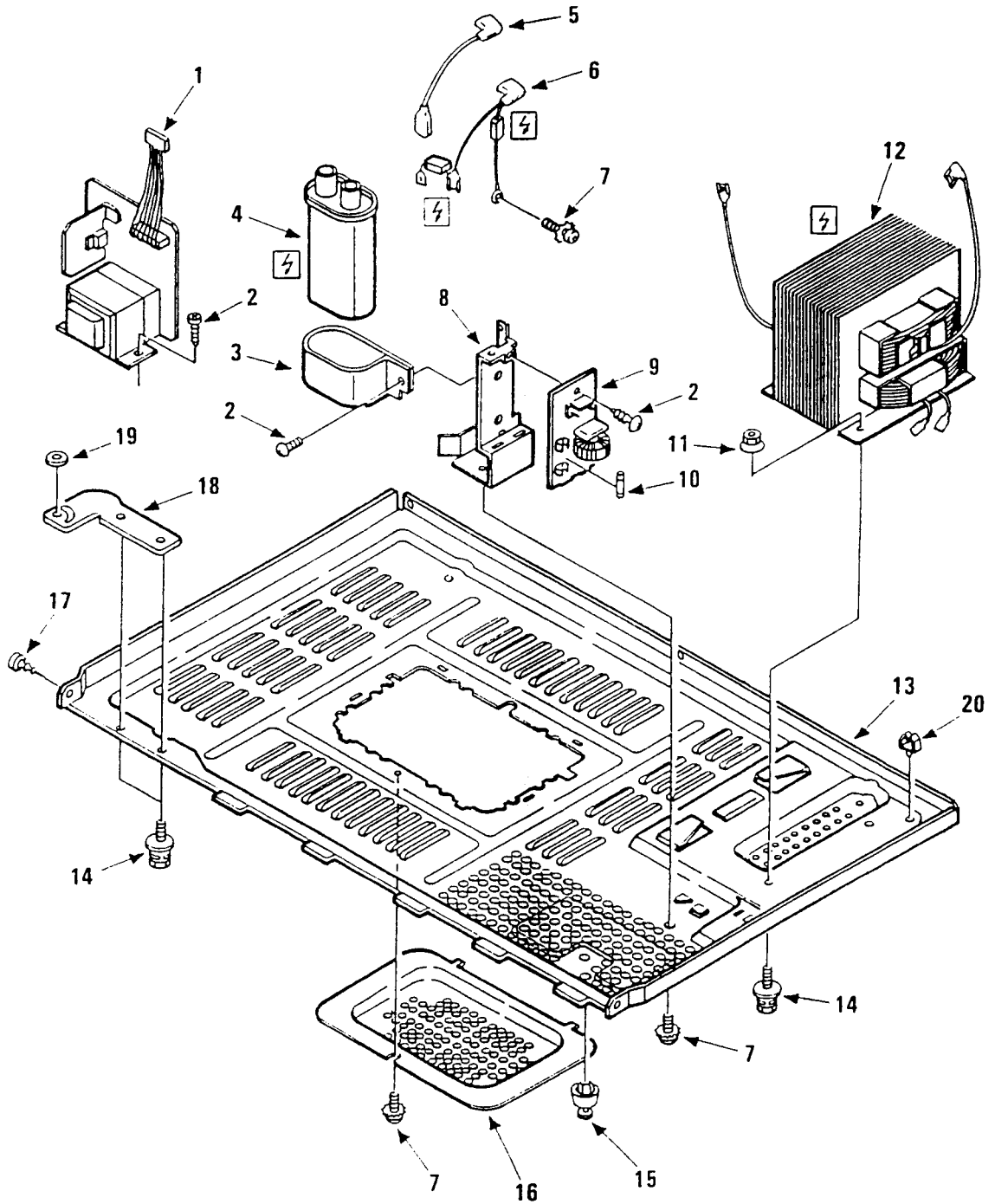
# MICROWAVE PARTS



Note: The sign  - The parts marked with  are supplied high voltage which is exceeded 250V.

Key No.	Part No.	Description	Q'ty
1	617 118 4419	Power Circuit Board Complete	1
2	411 006 9902	SCR TPG TRS 4x10 Z1	3
3	617 103 9146	Capacitor Band	1
4	617 118 4389	High Voltage Capacitor including Resistor, 1.15μF	1
5	617 103 9122	Lead Wire Ass'y (From Transformer to Capacitor)	1
6	617 119 9529	Lead Wire Ass'y with Diode	1
7	412 024 9400	SCR EVR PAN 4x12 Z1	3
8	617 103 9139	Terminal Bracket	1
9	617 118 4396	Terminal Circuit Board Complete	1

Key No.	Part No.	Description	Q'ty
10	423 018 3809	FUSE 250V 8A	1
11	411 004 3506	NUT HEX+FLG W/SRT 5 Z1	2
12	617 118 4433	High Voltage Transformer	1
13	617 111 7462	Bottom Plate	1
14	412 018 2103	BOLT HEX C-SCT 5x16 Z1	4
15	617 056 1655	Plastic Foot	4
16	617 111 7448	Cover, Gear Motor	1
17	411 006 3207	SCR TPG BIN 4x8 Z1	2
18	617 100 9897	Hinge, Lower	1
19	617 107 4260	Special Washer, 5x9x0.5 U	1
20	617 080 6152	Wire Clip	2

DOOR PARTS

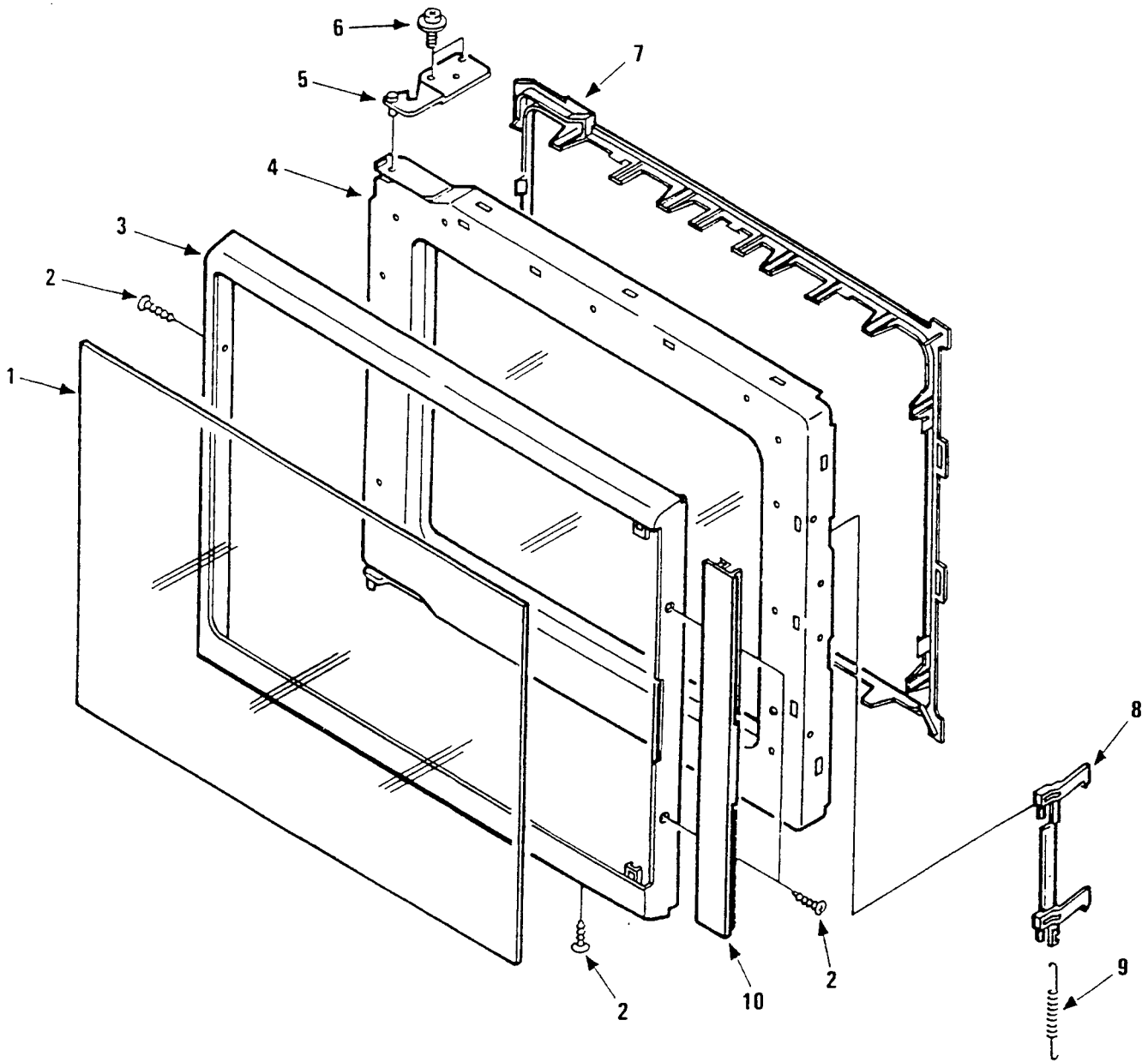

Key No.	Part No.	Description	Q'ty
1	617 118 4204	Door Panel, Outside	1
2	411 102 9202	SCR TPG FLT 3x12 C2	6
3	617 115 9868	Door Cover	1
4	617 122 6249	Door Main Frame with Door Panel	1
	617 111 7509	Door Main Frame	
	617 111 7530	Door Panel, Inside	

Key No.	Part No.	Description	Q'ty
5	617 103 8934	Hinge, Upper	1
6	617 102 7495	Special Screw	2
7	617 115 8311	Choke Dielectric	1
8	617 106 9594	Door Latch	1
9	617 101 0008	Spring	1
10	617 111 7561	Cover Plate	1

**CONTROL PANEL PARTS**

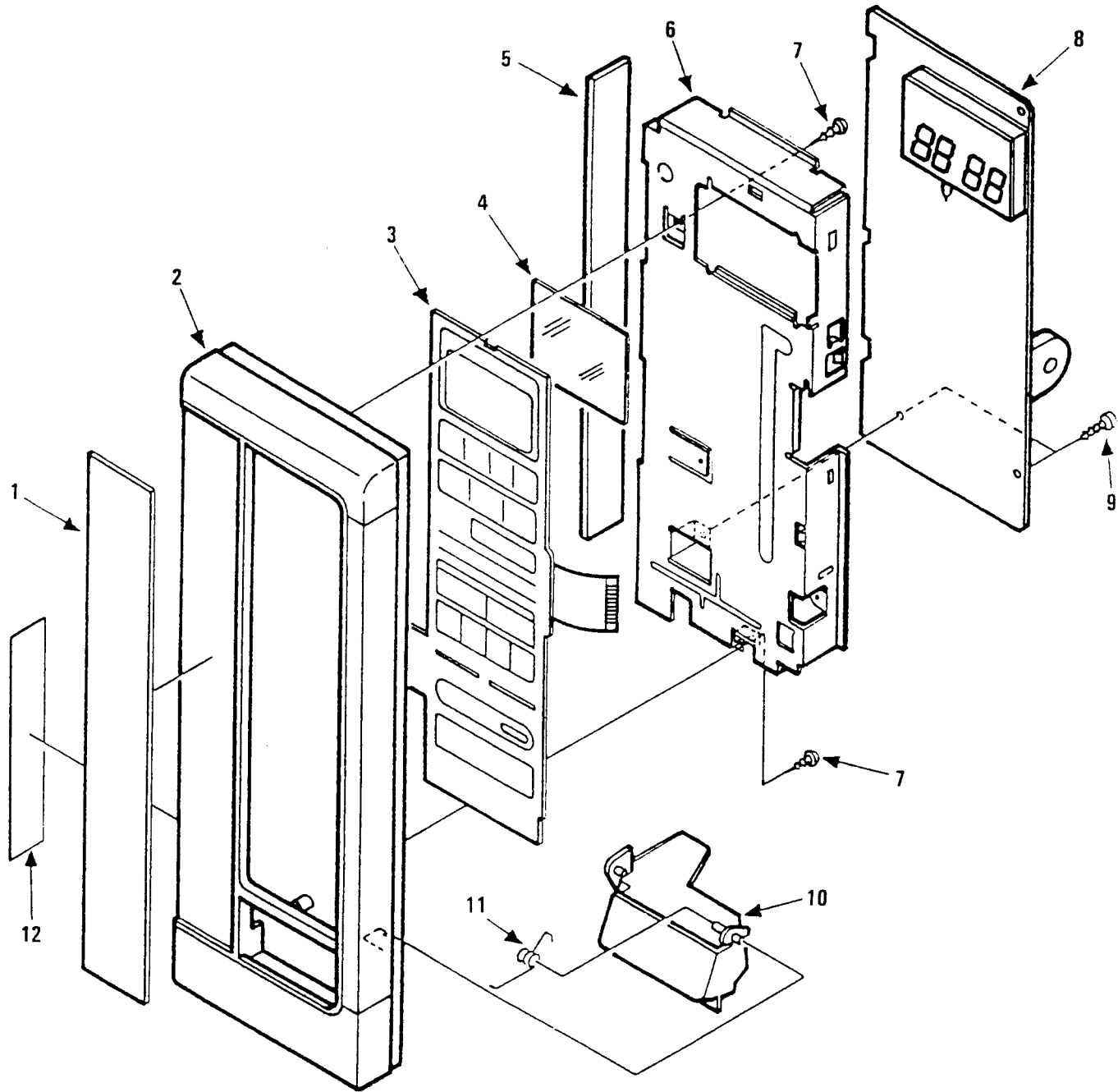

Key No.	Part No.	Description	Q'ty
1	617 106 0430	Control Plate	1
2	617 124 4267	Control Frame	1
3	617 118 4358	Touch Key Board	1
4	617 104 0302	Window Cover, Display	1
5	617 109 3889	Ferrite Rubber	1
6	617 111 8049	Control Base	1

Key No.	Part No.	Description	Q'ty
7	411 006 3207	SCR TPG BIN 4x8 Z1	2
8	617 118 4310	Control Circzit Board Complete	1
9	411 064 6608	SCR TPG BIN 3x8 Z1	2
10	617 106 8283	Door Release Lever	1
11	617 105 0127	Spring	2
12	617 120 3899	Name Plate	1

**PRINTED MATTER (Items Not Illustrated)**

Key No.	Part No.	Description	Q'ty
	617 120 3929	Operating Instructions	1

CONTROL CIRCUIT BOARD  
(Part No. 617 118 4310)

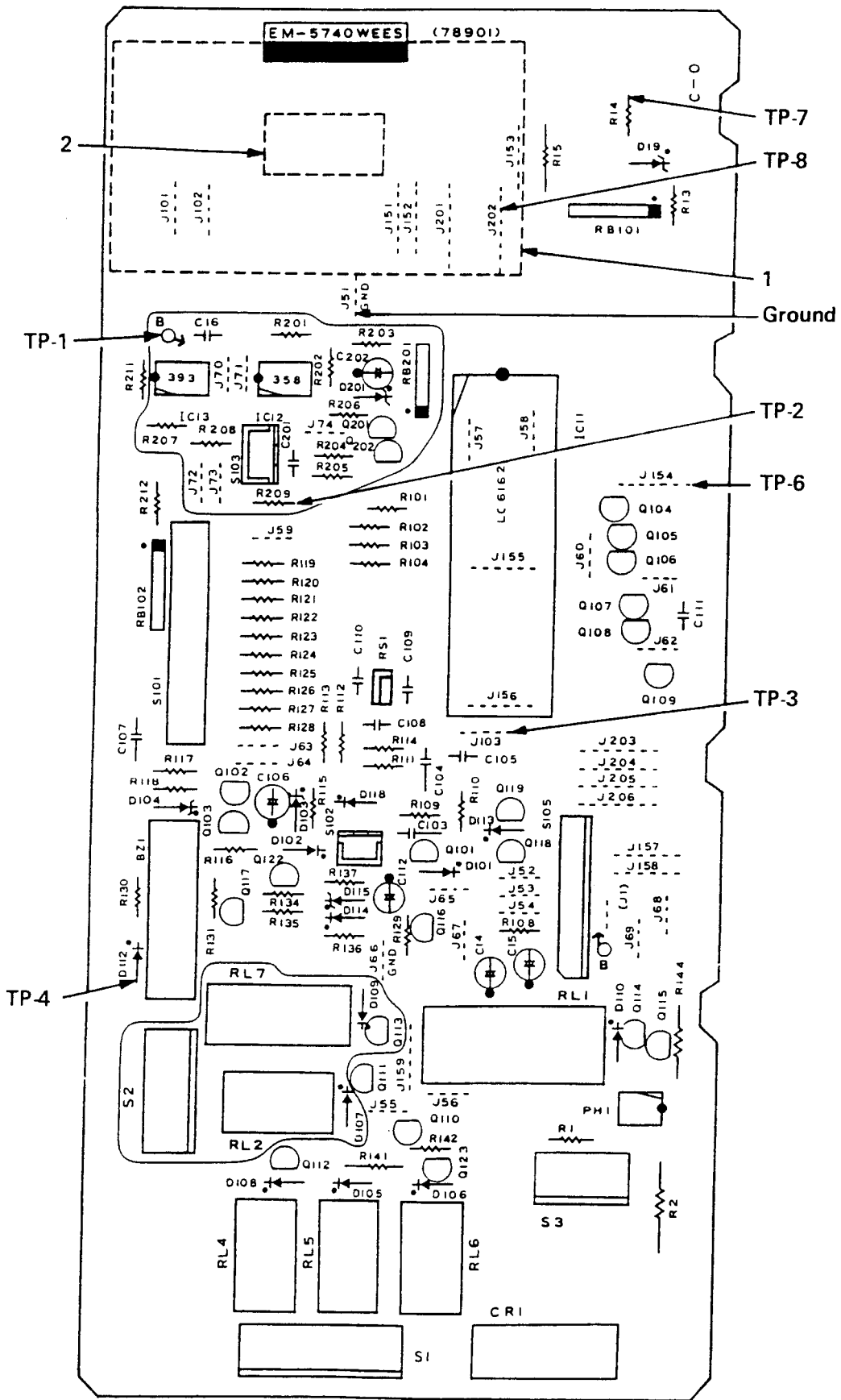



**CONTROL CIRCUIT BOARD**  
(Part No. 617 118 4310)

Schematic Location	Part No.	Description	Q'ty
<b>INTEGRATED CIRCUITS</b>			
IC11	409 222 4603	IC LC6162A-4437	1
IC12	409 057 3000	IC $\mu$ PC358C	1
	409 039 6500	IC NJM2904D	
	409 018 3605	IC LA6358	
	409 152 4209	IC AN1358	
IC13	409 018 3902	IC LA6393D	1
	409 057 3406	IC $\mu$ PC393C	
	409 174 7004	IC AN1393	
<b>TRANSISTORS</b>			
Q101,117	405 019 1909	TF 2SC536-E-NP	2
	405 017 9402	TR 2SC3330-R	
Q102,122	405 036 0800	TR 2SA1317-R	2
	405 004 4106	TR 2SA608-E-SP	
Q103	405 014 9108	TR 2SC3402	1
	405 000 3103	TR DTC114ES	
Q104-115	405 036 3108	TR 2SA1503	12
	405 036 3504	TR 2SA1524	
Q116,119	405 075 5507	TR 2SA1654	2
	405 000 1802	TR DTA143XS	
Q118	405 003 7900	TR 2SA1348	1
	405 000 0508	TR DTA114ES	
Q123	405 013 6801	TR 2SC2274-E	1
	405 013 7006	TR 2SC2274-F	
Q201,202	405 075 5705	TR 2SC4361	2
	405 000 5602	TR DTC143XS	
<b>DIODES</b>			
PH1	407 115 6406	PHOTO COUPLE TLP665J	1
D19	407 055 6900	ZENER DIODE	1
	407 051 5600	RD3.3ESB2 ZENER DIODE	
D101,102, 105-110, 112-114, 118	407 012 4406	GZS3.3Z-AT1 DIODE 1SS133	12
	407 007 9904	DIODE GMA01-AT1	
D103	407 056 8507	ZENER DIODE RD5.1ESB2	1
	407 051 6706	ZENER DIODE	
D104	407 075 2401	GZS5.1Y-AT1 ZENER DIODE	1
	407 070 8101	RD8.2ESB2 ZENER DIODE	
D115	407 101 6908	GZS8.2Y-AT1 ZENER DIODE	1
	407 051 5709	RD3.6ESB2 ZENER DIODE	
D201	407 055 6108	GZS3.6Z-AT1 ZENER DIODE	1
	407 070 4103	RD3.0ESB2 ZENER DIODE	
		GZS3.0Z-AT1	
<b>CAPACITORS</b>			
C14	403 177 0703	ELECT 47 $\mu$ M 25V	1
C15,106	403 177 0802	ELECT 47 $\mu$ M 10V	2
C16,111, 105,201	403 069 8305	CERAMIC 0.01 $\mu$ Z 50V	4
C103,104, 107	403 069 1207	CERAMIC 1000p K 50V	3

Schematic Location	Part No.	Description	Q'ty
C108	403 114 3507	CERAMIC 0.1 $\mu$ Z 25V	1
C109,110	403 018 6901	CERAMIC 220p J 50V	2
C112	403 177 0505	ELECT 0.47 $\mu$ M 50V	1
C202	403 173 2404	ELECT 1 $\mu$ M 50V	1
<b>RESISTORS</b>			
R1	401 012 4404	CARBOH 100JA $\frac{1}{4}$ W	1
R2	401 060 2704	OXIDE-MT 220 JA 1W	1
R13, 110-112, 114, 119-128, 137,211, 212	401 012 6903	CARBON 10K JA $\frac{1}{4}$ W	18
R14,15, 115,117, 134	401 012 5609	CARTON 1K JA $\frac{1}{4}$ W	5
R101-104	401 016 4707	CARBON 22K JA $\frac{1}{4}$ W	4
R108,141	401 016 3700	CARBON 2.2K JA $\frac{1}{4}$ W	2
R109	401 018 3708	CARBON 3.3K JA $\frac{1}{4}$ W	1
R113	401 012 8006	CARBON 100K JA $\frac{1}{4}$ W	1
R116	401 023 1607	CARBON 820 JA $\frac{1}{4}$ W	1
R118,135	401 021 1807	CARBON 560 JA $\frac{1}{4}$ W	2
R129	401 022 1806	CARBON 680 JA $\frac{1}{4}$ W	1
R130	401 015 4609	CARBON 180K JA $\frac{1}{4}$ W	1
R131	401 019 1802	CARBON 3.9K JA $\frac{1}{4}$ W	1
R136	401 023 3601	CARBON 82K JA $\frac{1}{4}$ W	1
R142	401 017 2702	CARBON 27K JA $\frac{1}{4}$ W	1
R144	401 010 7407	CARBON 560 JA $\frac{1}{4}$ W	1
R201	401 103 1404	MT-FILM 21.5K FD $\frac{1}{4}$ W	1
R202	401 052 8301	MT-FILM 12.7K FD $\frac{1}{4}$ W	1
R203	401 097 0506	MT-FILM 6.19K FD $\frac{1}{4}$ W	1
R204	401 087 3401	MT-FILM 2K FD $\frac{1}{4}$ W	1
R207	401 103 0001	MT-FILM 95.3K FD $\frac{1}{4}$ W	1
R206	401 019 0904	CARBON 390 JA $\frac{1}{4}$ W	1
R207	401 021 4907	CARBON 560K JA $\frac{1}{4}$ W	1
R208	401 096 7803	MT-FILM 6.98K FD $\frac{1}{4}$ W	1
R209	401 142 4800	MT-FILM 6.04K FD $\frac{1}{4}$ W	1
<b>RESISTOR BLOCKS</b>			
RB101,102	617 010 3541	100Kohms $\pm$ 10%, 5-pc Resistor Block	2
RB201	617 000 2158	18.7Kohms, 4-bit Resistor Block	1
<b>MISCELLANEOUS</b>			
BZ1	617 002 6338	Buzzer, PKM30SPT-2003	1
RS1	617 000 8860	Ceramic Resonator, KBR-800H	1
CR1	617 000 0758	Noise Filter, 0.1 $\mu$ F+120ohms	1
RL1	617 111 4881	Relay, DH1PU	1
RL2,3,5,6	617 100 2348	Relay, OJ-SH-112LM	4
RL7	617 118 5409	Relay, G5P-1-H-T115	1
S1	617 002 3504	Connector, 4/7P	1
S2	617 002 3474	Connector, 3/5P	1
S3	617 118 6338	Connector, 3/4P	1
S101	617 002 2330	Connector, 10P	1
S102	617 002 3979	Connector, 2P	1
S103	617 002 4082	Connector, 3P	1
S105	617 111 7387	Connector, 10P	1
1	617 111 4911	Display Tube, FIP4XM10	1
2	617 079 4176	Spacer, Display Tube	1

**POWER CIRCUIT BOARD**  
(Part No. 617 118 4419)

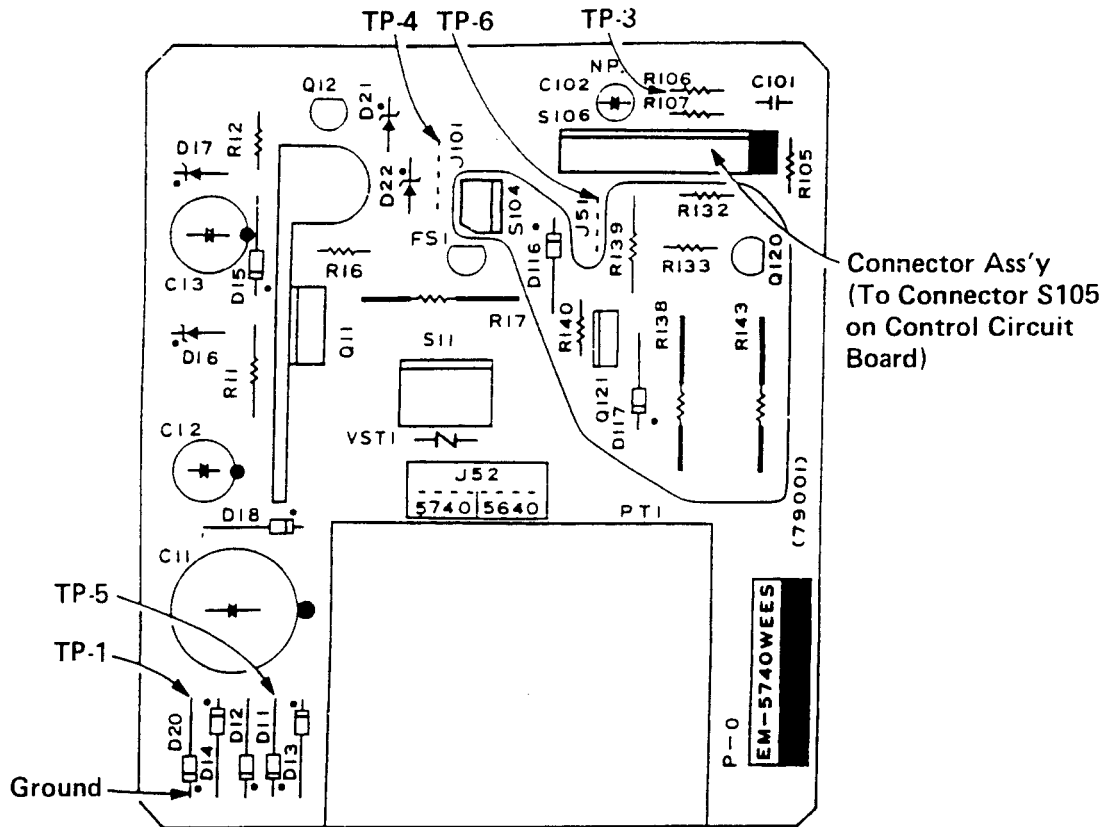

Connector Ass'y  
(To Connector S105  
on Control Circuit  
Board)

Schematic Location	Part No.	Description	Q'ty
<b>TRANSISTORS</b>			
Q11	617 117 9064	Transistor Assembly	1
	405 007 0907	TR 2SB507-E	
	405 007 1102	TR 2SB507-F	
	617 077 5441	Heat Sink	
	411 006 6604	SCR TPG PAN 3x6 Z1	
Q12	405 009 5207	TR 2SB927-S	1
	405 009 5306	TR 2SB927-T	
Q120	405 013 6801	TR 2SC2274-E	1
	405 013 7006	TR 2SC2274-F	
Q121	405 024 2809	TR 2SD600-E	1
	405 024 2908	TR 2SD600-F	
<b>DIODES</b>			
D11-15, 18,20, 116,117	407 072 0202	DIODE DSF10TE-AT1	9
	407 004 9600	DIODE DSF10TC-AT1	
D16	407 054 5003	ZENER DIODE	1
	407 051 4405	RD13ESB2	
D17	407 051 4405	ZENER DIODE	1
	407 057 0500	GZS13Y-AT1	
D21,22	407 051 7000	ZENER DIODE	2
	407 095 9305	RD5.6ESB3	
	407 070 1904	ZENER DIODE	
		GZS5.6Z-AT1	

Schematic Location	Part No.	Description	Q'ty
<b>CAPACITORS</b>			
C11	403 053 4702	ELECT 2200μ M 35V	1
C12	403 049 7502	ELECT 100μ M 50V	1
C13	403 054 3100	ELECT 470μ M 35V	1
C101	403 069 8305	CERAMIC 0.01μ Z 50V	1
C102	403 135 1100	NP-ELECT 0.47μ M 50V	1
<b>RESISTORS</b>			
R11	401 008 7402	CARBON 2.2K JA ½W	1
R12	401 014 4006	CARBON 1.5K :A ¼W	1
R16	401 015 1509	CARBON 180 JA ¼W	1
R17	401 065 5809	OXIDE-MT 15 JA 2W	1
R105	401 020 2805	CARBON 47K JA ¼W	1
R106	401 016 4707	CARBON 22K JA ¼W	1
R107	401 022 4005	CARBON 68K JA ¼W	1
R132	401 019 1802	CARBON 3.9W JA ¼W	1
R133,140	401 017 2702	CARBON 27K JA ¼W	2
R138,143	401 066 6102	OXIDE-MT 220 JA 2W	2
R139	401 008 1400	CARBON 1.8K JA ¼W	1
<b>MISCELLANEOUS</b>			
FS1	409 195 3009	IC ICP-N5	5
VST1	407 045 3704	VARISTOR	1
PT1	617 111 4928	ERZ-C10DK471 Step-down Transformer, PE5M-5740	1
S11	617 002 3412	Connector, 2/3P	1
S104	617 100 9354	Connector, 2P	1
S106	617 111 7318	Connector Assembly, 10P	1

10. OVERALL CIRCUIT BOARD

