

3-1-3. LCD SECTION

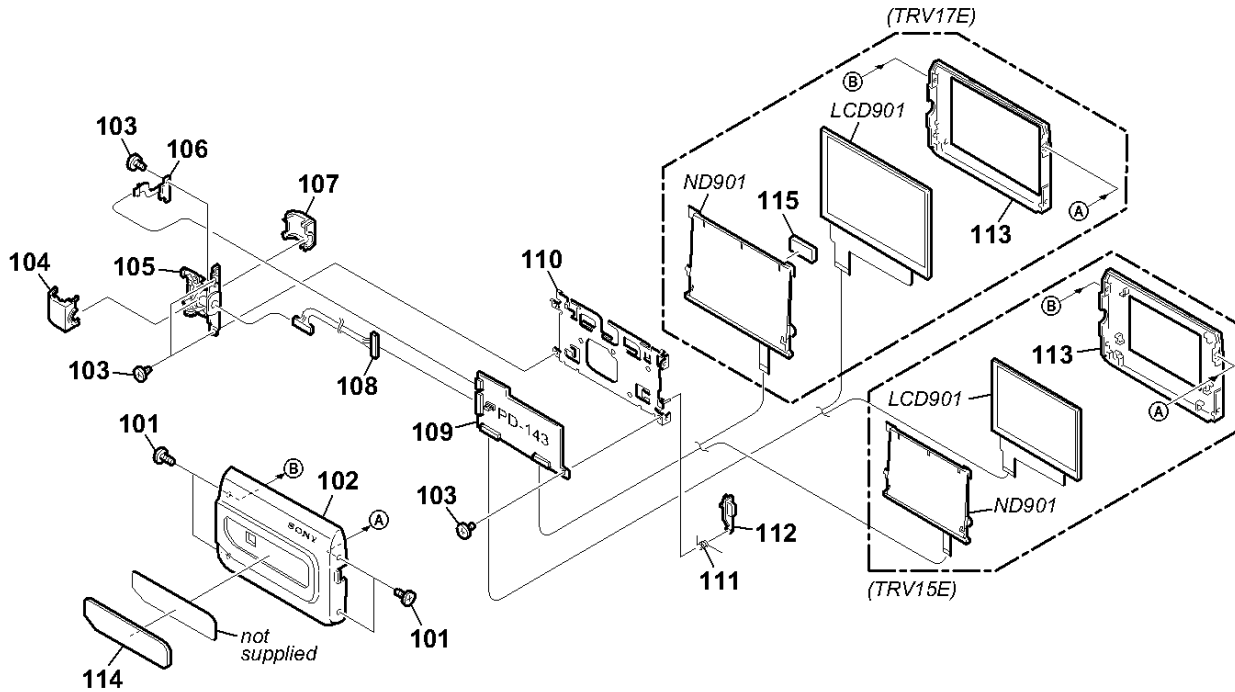

Ref. No.	Part No.	Description	Remarks	Ref. No.	Part No.	Description	Remarks
101	3-968-729-91	SCREW (M2), LOCK ACE, P2		111	3-059-740-01	SPRING (P), TORSION	
102	X-3951-421-1	CABINET (C) ASSY, P		112	3-059-739-01	BUTTON, PANEL OPEN	
103	4-974-725-01	SCREW (M1.7X2.5), P		113	3-066-821-01	CABINET (M) (3.5), P (TRV17E)	
104	3-066-822-01	COVER (FRONT), HINGE		113	3-067-753-01	CABINET (M) (2.5), P (TRV15E)	
105	X-3951-724-1	HINGE ASSY (1730)		114	3-066-736-31	PLATE, P ORNAMENTAL (TRV17E)	
106	A-7074-778-A	FP-309 FLEXIBLE BOARD, COMPLETE		114	3-066-736-41	PLATE, P ORNAMENTAL (TRV15E)	
107	3-066-823-01	COVER (REAR), HINGE		115	3-069-291-01	BL SHEET (TRV17E)	
108	1-961-121-11	HARNESS (PV-130)		LCD901	not supplied	INDICATOR MODULE LIQUID CRYST (2.5)	(TRV15E)
109	not supplied	PD-143 (35SH123) BOARD, COMPLETE	(TRV17E)	LCD901	not supplied	INDICATOR MODULE LIQUID CRYST (3.5)	(TRV17E)
109	not supplied	PD-143 (25SH123) BOARD, COMPLETE	(TRV15E)	△ND901	not supplied	TUBE, FLUORESCENT, COLD CATHODE (3.5)	(TRV17E)
110	X-3951-420-1	FRAME ASSY (3.5), P (TRV17E)		△ND901	not supplied	TUBE, FLUORESCENT, COLD CATHODE (2.5)	(TRV15E)
110	X-3951-547-1	FRAME ASSY (2.5), P (TRV15E)					

Note : The components identified by mark △ or dotted line with mark △ are critical for safety. Replace only with part number specified.