

3-1-4. CABINET (L) SECTION

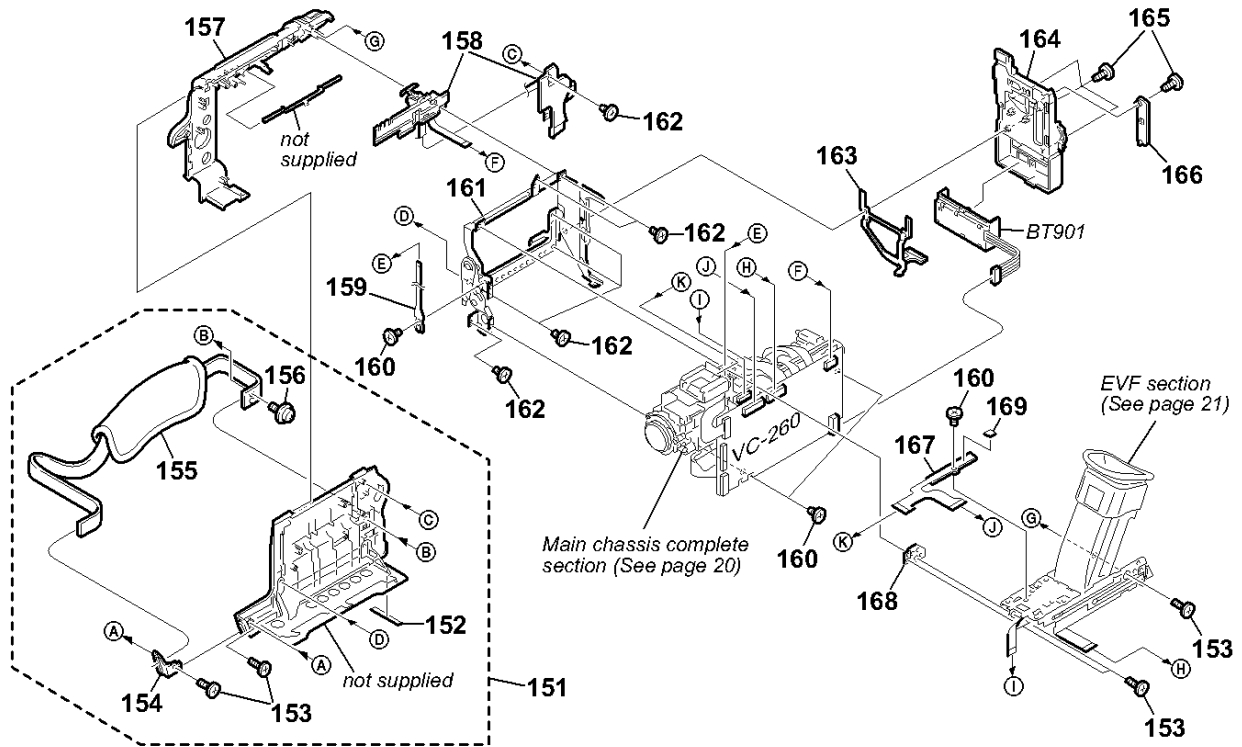

Ref. No.	Part No.	Description	Remarks	Ref. No.	Part No.	Description	Remarks
151	X-3951-427-1	CABINET ASSY, GRIP (TRV17E)		160	4-974-725-01	SCREW (M1.7X2.5), P	
151	X-3951-548-1	CABINET ASSY, GRIP (TRV15E)		161	X-3951-438-1	FRAME ASSY, CS	
* 152	3-055-189-01	FOOT (A)		162	3-713-791-51	SCREW (M1.7X3.5), TAPPING, P2	
153	3-713-791-11	SCREW (M1.7X5), TAPPING, P2		163	3-067-024-01	BRACKET (LOWER), STRAP	
154	3-059-825-01	BRACKET (FRONT), GRIP BELT		164	X-3951-428-1	PANEL ASSY, BT	
155	3-061-550-01	BELT, GRIP		165	3-989-735-81	SCREW (M1.7), LOCK ACE, P2	
156	3-679-362-11	SCREW		166	3-067-025-01	CPC LID	
157	X-3951-419-1	CABINET (L) ASSY (TRV17E)		167	A-7074-777-A	FP-305 FLEXIBLE BOARD, COMPLETE	
157	X-3951-549-1	CABINET (L) ASSY (TRV15E)		168	3-066-847-01	SPACER, M	
158	1-476-579-11	SWITCH BLOCK, CONTROL (PS-1700)		169	3-068-717-01	CUSHION LL	
159	A-7074-779-A	FP-310 FLEXIBLE BOARD, COMPLETE		BT901	1-694-772-11	TERMINAL BOARD, BATTERY	