

Service Manual

CD Changer

Compact Disc Changer

SL-CA10



Colour

(K)...Black Type

Area

Suffix for Model No.	Area	Colour
(E)	Europe, Asia, Latin America, Middle East, Africa and Oceania.	(K)

System: SC-CA10

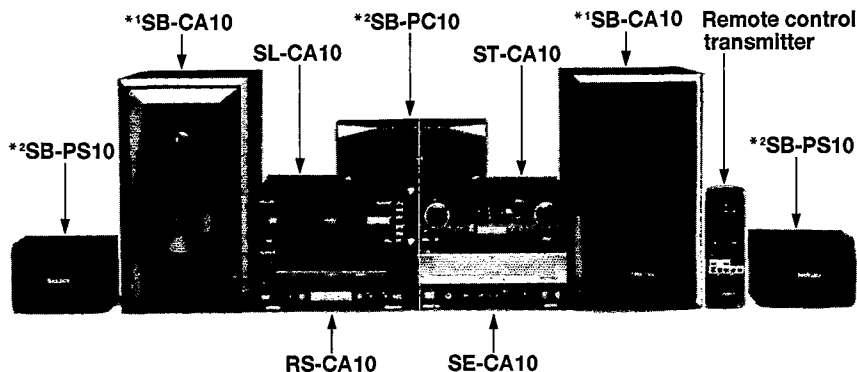

Because of unique interconnecting cables, when a component requires service, send or bring in the entire system.

RAE0150Z MECHANISM SERIES

SPECIFICATIONS

■ Audio	
DA converter	1 bit 2 DAC MASH [※]
■ Pickup	
Wavelength	780 nm
■ General	
Dimensions (W×H×D)	280×89×331 mm
Weight	2.5 kg

Notes:

1. Weight and dimensions shown are approximate.
2. Design and specifications are subject to change without notice.

[※] MASH is a trademark of NTT.

System	Tuner	CD changer	Amplifier	Cassette deck	Speakers
SC-CA10	ST-CA10	SL-CA10	SE-CA10	RS-CA10	*1 SB-CA10 *2 SB-PC10 (Center) (SB-PC10+SB-PS10)

*1 Made in PAES
*2 For (E, EB, EG) Areas.....Made in PAES
For (GC, GN) Areas.....Made in NABEL

⚠ WARNING

This service information is designed for experienced repair technicians only and is not designed for use by the general public. It does not contain warnings or cautions to advise non-technical individuals of potential dangers in attempting to service a product. Products powered by electricity should be serviced or repaired only by experienced professional technicians. Any attempt to service or repair the product or products dealt with in this service information by anyone else could result in serious injury or death.



© 1995 Matsushita Electric Industrial Co., Ltd.
All rights reserved. Unauthorized copying and distribution is a violation of law.

CONTENTS

	Page		Page
PRECAUTION OF LASER DIODE	2	TROUBLE SHOOTING (SERVO CIRCUIT)	20, 21
LOCATION OF CONTROL	3	BLOCK DIAGRAM	22~24
LISTENING TO COMPACT DISCS	3	SCHEMATIC DIAGRAM	25~29
HANDLING PRECAUTIONS FOR TRAVERSE DECK	4	PRINTED CIRCUIT BOARD DIAGRAM	30~32
REPLACEMENT OF THE FOOT	4	WIRING CONNECTION DIAGRAM	32
OPERATION CHECK AND MAIN COMPONENT		TERMINAL GUIDE	33~36
REPLACEMENT PROCEDURES	5~16	RESISTORS AND CAPACITORS	37, 38
ERROR CODE DISPLAY AND SERVO		REPLACEMENT PARTS LIST	38, 41, 42
ADJUSTMENT FUNCTION	17, 18	CABINET PARTS LOCATION	39
MEASUREMENTS AND ADJUSTMENTS	19	LOADING MECHANISM PARTS	40

NOTE:
Refer to the service manual for Model No. SE-CA10 (ORDER No. AD9512272C8) for information on "ACCESSORIES", "INSTALLATION", "CONNECTIONS" and "PACKAGING".

PRECAUTION OF LASER DIODE

CAUTION: This product utilizes a laser diode with the unit turned "on", invisible laser radiation is emitted from the pickup lens.

Wave length: 780 nm
Maximum output radiation power from pickup: 100 μW/VDE

Laser radiation from the pickup lens is safety level, but be sure the followings:

1. Do not disassemble the optical pickup unit, since radiation from exposed laser diode is dangerous.
2. Do not adjust the variable resistor on the pickup unit. It was already adjusted.
3. Do not look at the focus lens using optical instruments.
4. Recommend not to look at pickup lens for a long time.

ACHTUNG: Dieses Produkt enthält eine Laserdiode. Im eingeschalteten Zustand wird unsichtbare Laserstrahlung von der Lasereinheit abgestrahlt.

Wellenlänge: 780 nm
Maximale Strahlungsleistung der Lasereinheit: 100 μW/VDE

Die Strahlung an der Lasereinheit ist ungefährlich, wenn folgende Punkte beachtet werden:

1. Die Lasereinheit nicht zerlegen, da die Strahlung an der freigelegten Laserdiode gefährlich ist.
2. Den werkseitig justierten Einstellregler der Lasereinheit nicht verstellen.
3. Nicht mit optischen Instrumenten in die Fokussierlines blicken.
4. Nicht über längere Zeit in die Fokussierlines blicken.

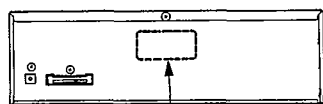

**LUOKAN 1 LASERLAITE
KLASS 1 LASER APPARAT**

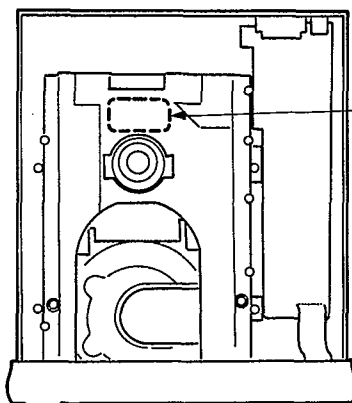

DANGER	INVISIBLE LASER RADIATION WHEN OPEN. AVOID DIRECT EXPOSURE TO BEAM.
ADVARSEL	USYNLIG LASERSTRÅLING VED ÅBNING. VÅR SIKKERHEDSABRYDDERE ER UDE AF FUNKTION. UDEGÅ UDSÆTTELSE FOR STRÅLING.
VARO!	AVATTAESSA JA SUOJALUKITUS OHITETTAESSA OLET ALLITEN NÄKYMÄTÖNTÄ LASERSÄTELYLLE. ÄLÄ KATSO SÄTEESEEN.
VARNING	OSYNLIG LASERSTRÅLNING NÄR DENNA DEL ÄR ÖPPNAD OCH SPÄRREN ÄR URKOPPLAD. BETRÄKTA EJ STRÅLEN.
ADVARSEL	USYNLIG LASERSTRÅLING NÄR DEKSEL ÅPNES OG SIKKERHEDSÅBS BRYTES. UDEGÅ EKSPONERING FOR STRÅLEN.
VORSICHT	UNSICHTBARE LASERSTRÄHLUNG, WENN ABDECKUNG GEÖFFNET. NICHT DEM STRAHLEN AUSSETZEN. ROLSO104

CAUTION!
THIS PRODUCT UTILIZES A LASER.
USE OF CONTROLS OR ADJUSTMENTS OR PERFORMANCE OF PROCEDURES OTHER THAN THOSE SPECIFIED HEREIN MAY RESULT IN HAZARDOUS RADIATION EXPOSURE.

LOCATION OF CONTROL

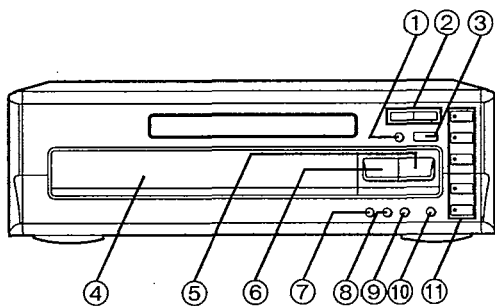

- ① Pause button (II)
- ② Skip/search buttons (SKIP/SEARCH)
- ③ Disc tray open/close button (▲ OPEN/CLOSE)
- ④ Disc tray
- ⑤ Play button and indicator (▶)
- ⑥ Stop button (□)
- ⑦ Random play button (RANDOM)
- ⑧ Repeat button (REPEAT)
- ⑨ AI edit button (AI EDIT)
- ⑩ Disc check button (DISC CHECK)
- ⑪ Disc select buttons and indicators (DISC)

LISTENING TO COMPACT DISCS

Always stop the changer before loading or changing CDs. You cannot change CDs while a disc is playing.

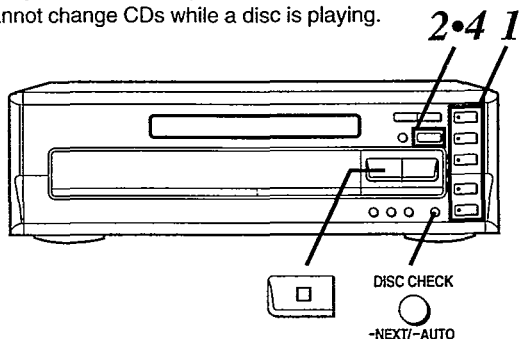

How to load CDs

- 1 Press DISC 1–5, whichever you want to open.
- 2 Press ▲ OPEN/CLOSE.
- 3 Set the CD in the tray.

•How to hold CDs

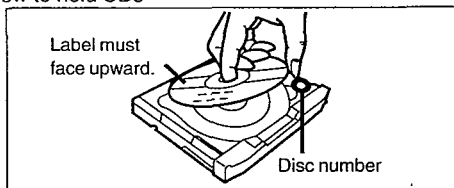

•Load CDs as shown below.

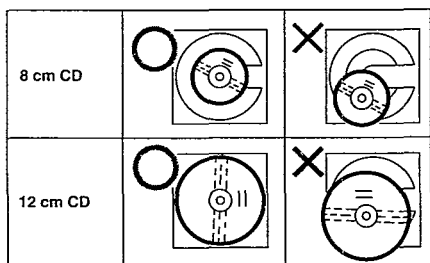

- 4 Press ▲ OPEN/CLOSE.

The open tray will close.

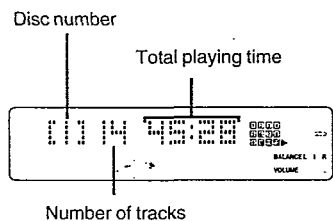

- 5 To load other CDs, repeat steps 1 through 4.

For your reference:

If the tray you want to open is already shown on the display, you obviously do not need to perform step 1.

How to check which trays have discs

DISC CHECK is a convenient way to know what discs you have in your changer and where.

Press DISC CHECK (-NEXT).

Not the disc number shown on the display, but the next tray after that will open. For example, when disc 4 is displayed, tray 5 will open.

- Every time you press the button, the next tray opens.
- You can change the CD while the tray is open.
- To close the tray, press ▲ OPEN/CLOSE.

Hold down DISC CHECK (-AUTO).

The trays will open (and close) automatically one after another. The first one to open will be the next tray after the disc number shown on the display. This way, you can check all trays in a row.

- To stop the auto check in course, press □.

Note

Do not attempt to change CDs while trays are opening and closing in the auto check.

Disc indicators

When you open or close a tray with the ▲ OPEN/CLOSE button, the changer automatically detects whether there is a CD in the tray or not. The indicator will act as follows.

● (red)	There's a CD in the tray.
Out	There isn't a CD in the tray.

While the CD is playing, its indicator is green.

Note

In the following cases, CD detection is OFF. The indicators will be red whether there is a disc in the tray or not.

- When the tray is closed with DISC CHECK
- When the tray is closed with DISC 1–5
- When the tray is closed by selecting a mode other than CD

For your reference:

While the CD changer is changing discs, the disc indicators act as follows.

- All the indicators the changer skips through will flash.
- The indicator of the selected disc (or last disc in auto DISC CHECK) will light up.

■ HANDLING PRECAUTIONS FOR TRAVERSE DECK

The laser diode in the traverse deck (optical pickup) may break down due to potential difference caused by static electricity of clothes or human body.

So, be careful of electrostatic breakdown during repair of the traverse deck (optical pickup).

● Handling of traverse deck (optical pickup)

1. Do not subject the traverse deck (optical pickup) to static electricity as it is extremely sensitive to electrical shock.
2. The short land between the No. ④ (LD) and No. ⑤ (GND) pins on the flexible board (FFC) is shorted with a solder build-up to prevent damage to the laser diode. To connect to the PC board, be sure to open by removing the solder build-up, and finish the work quickly.
3. Take care not to apply excessive stress to the flexible board (FFC).
4. Do not turn the variable resistor (laser power adjustment). It has already been adjusted.

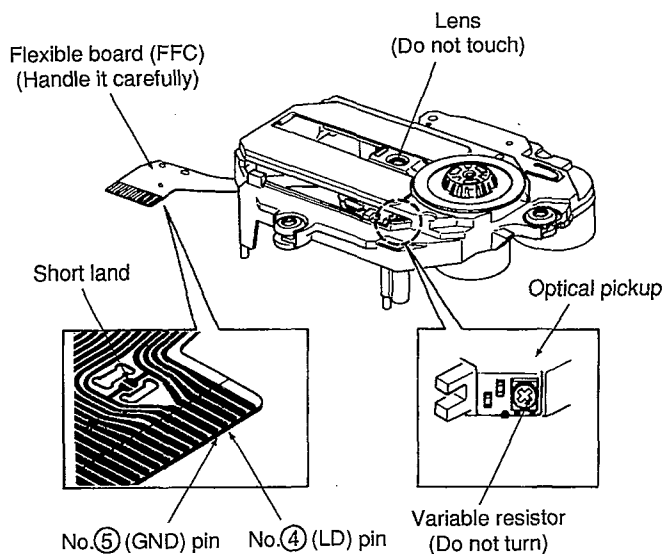

● Grounding for electrostatic breakdown prevention

1. Human body grounding
Use the anti-static wrist strap to discharge the static electricity from your body.
2. Work table grounding
Put a conductive material (sheet) or steel sheet on the area where the optical pickup is placed, and ground the sheet.

Caution:

The static electricity of your clothes will not be grounded through the wrist strap. So, take care not to let your clothes touch the traverse deck (optical pickup).

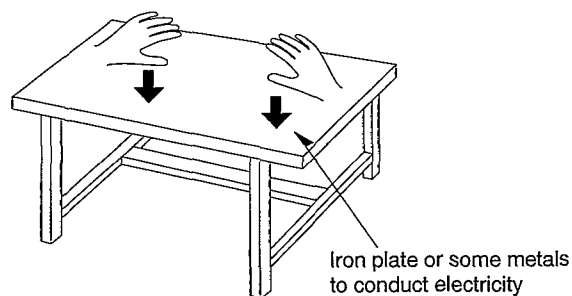
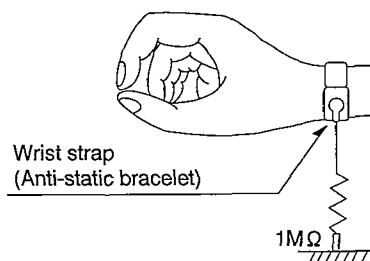

■ Operation Check and Main Component Replacement Procedures

- NOTE**
1. This section describes procedures for checking the operation of the major printed circuit boards and replacing the main components.
 2. For reassembly after operation checks or replacement, reverse the respective procedures. Special reassembly procedures are described only when required.
 3. Select items from the following index when checks or replacement are required.
 4. Illustrated screws are equivalent to actual size.
 5. Refer the parts No. on the page of "Main Component Replacement Procedures", if necessary.

● Contents

• CD Changer Disassembly / Reassembly	page.
1. Removal for the CD changer unit.	5.
2. Removal for the traverse unit.	7.
3. Disassembly for the CD changer unit.	7,8.
4. Reassembly for the CD changer unit.	9-12.
5. Inspection for the CD changer unit.	12.
• Checking Procedures for each P.C.B.	
1. Checking for the main P.C.B. and the operation P.C.B..	13.
2. Checking for the servo P.C.B..	13,14.
• Main Component Replacement Procedures	
1. Replacement for the traverse deck ass'y.	14-16.

■ CD Changer Disassembly / Reassembly

Removal for the CD changer unit

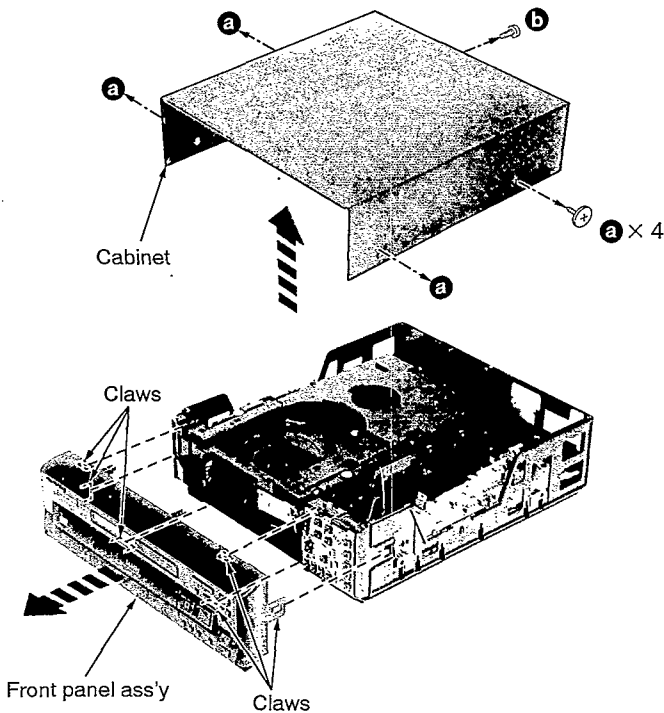

- Step 1** Remove the 5 screws.
- Step 2** Remove the cabinet.
- Step 3** Release the 6 claws, and then remove the front panel ass'y.

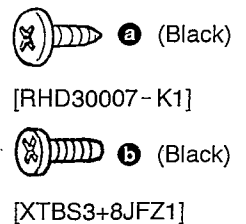

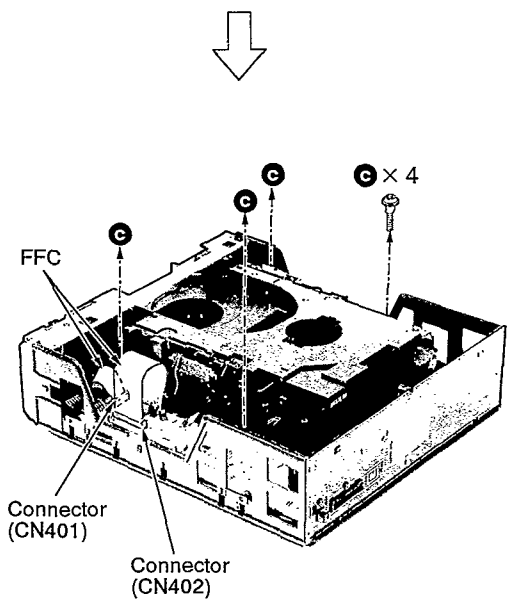

Step 4 Pull out the FFC (2 points).

Step 5 Remove the 4 screws.

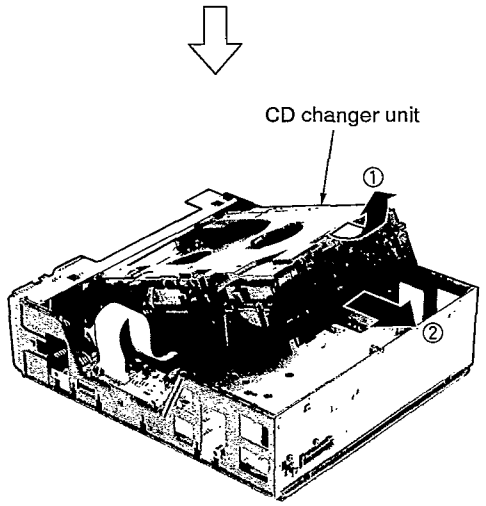
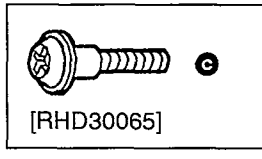

Step 6 With lifting the rear side of CD changer unit, pull it backward.

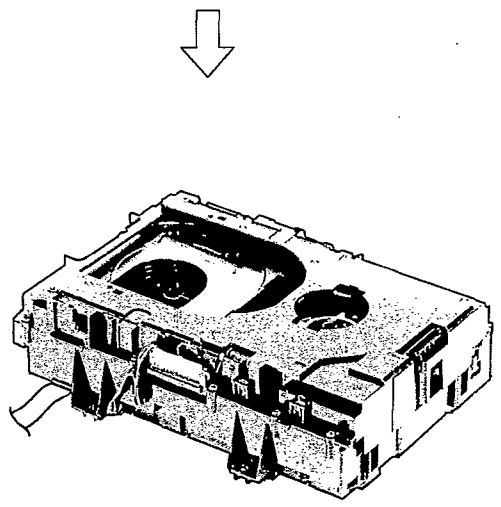

The CD changer unit will be removed.

Removal for the traverse unit

NOTE

Locate the traverse unit to the position "DOWN".

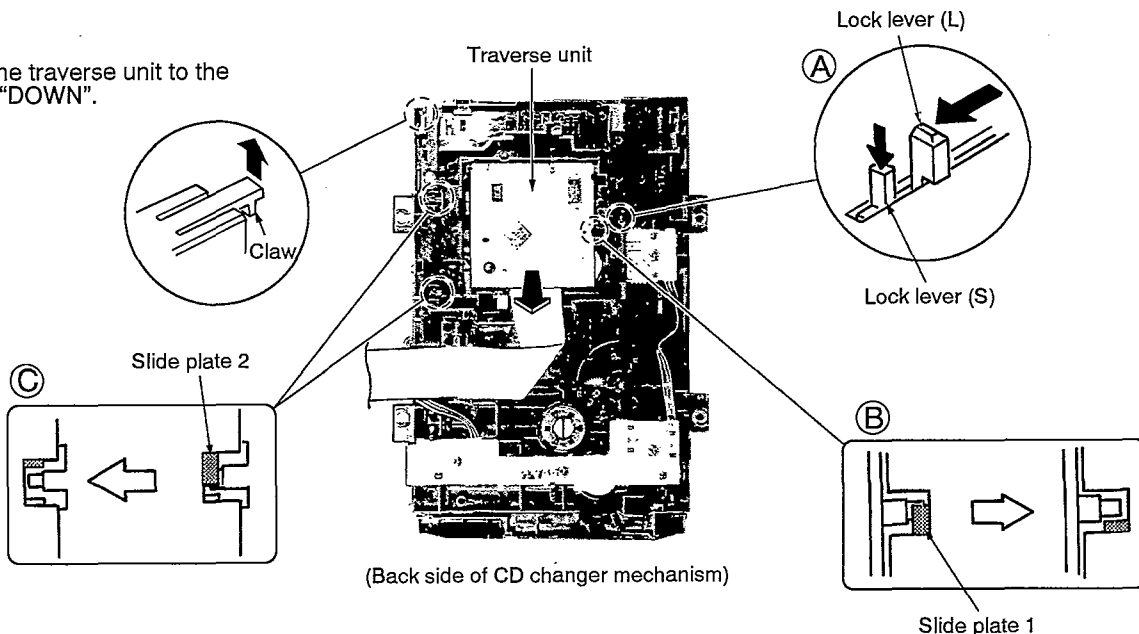

Procedures

- Step 1** Push the lock lever (S) with lifting the claw, and then push the lock lever (L) in the direction of arrow (→). Refer to the figure (A).
- Step 2** The slide plate 1 and 2 of traverse retain boss (B) and (C) are open. Refer to the figures (B) and (C).
- Step 3** Push the traverse unit in the direction of arrow (→). (The FFC is connected.)
- Step 4** The traverse unit will be removed.

Disassembly for the CD changer unit

NOTE

Locate the traverse unit to the position "DOWN".

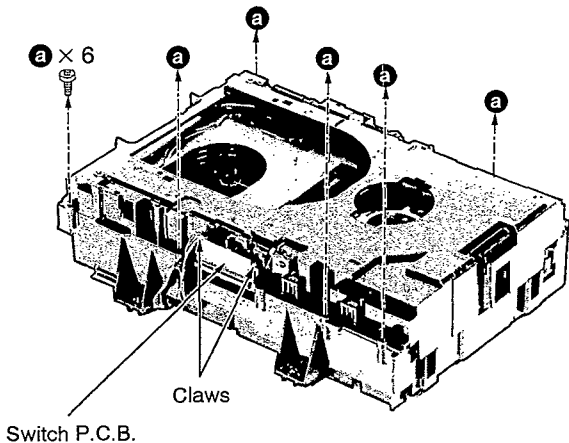

- Step 1** Remove the switch P.C.B..
- Step 2** Remove the 6 screws.

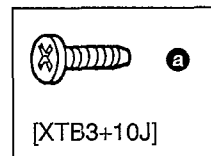

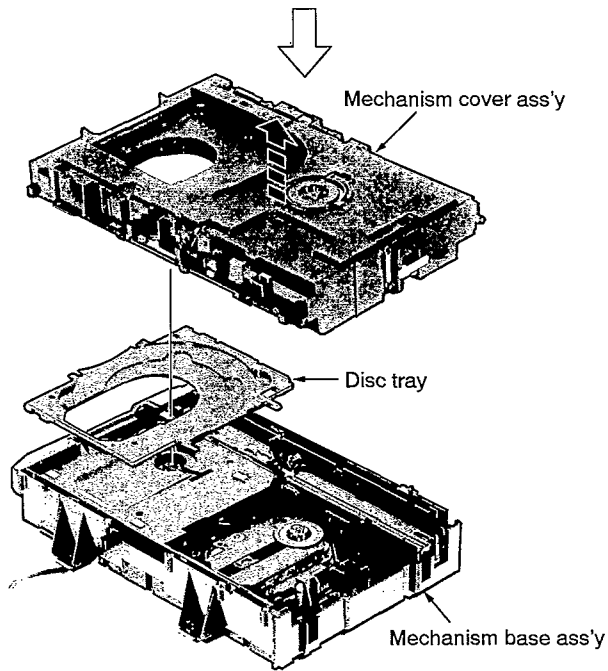

Step 3 Remove the mechanism cover ass'y.

⚠ 4 disc trays contacted to the mechanism cover ass'y will be removed.
1 disc tray is removed to the mechanism base ass'y.

Step 4 Remove the disc tray sided mechanism base ass'y.

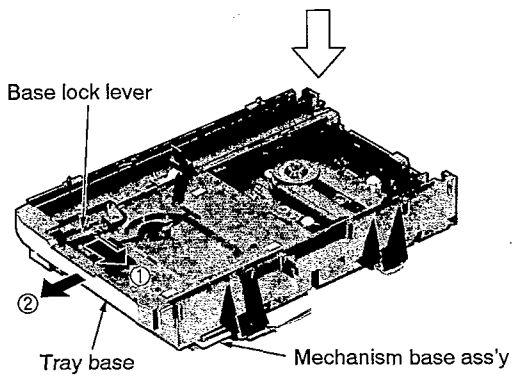

Step 5 Unlock the base lock lever.

Step 6 Draw the tray base until it will be stopped.

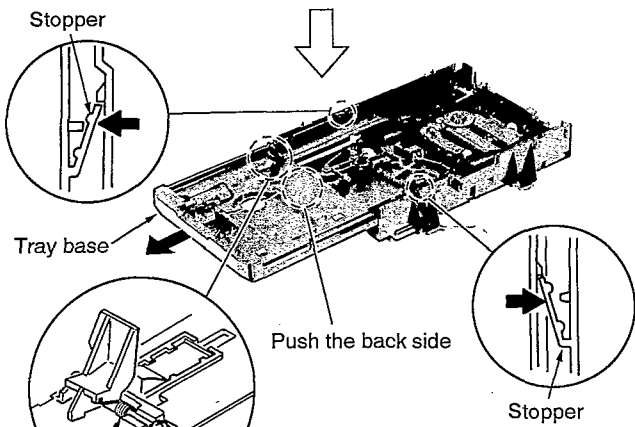

Step 7 Release the stopper manually.

Step 8 Draw the tray base.

⚠ In case that the tray base can not be open due to hooking, draw the tray base with finger pressing the back side indicated by ○ of base. (Take care handling of stopper.)

⚠ Take care not avoid the carrier lock lever spring.

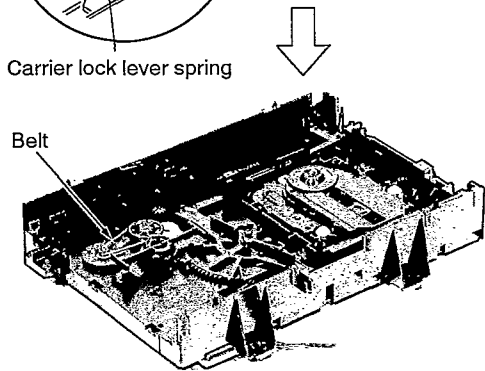

The belt and each part can be replaced after above procedures are performed.

Reassembly for the CD changer unit

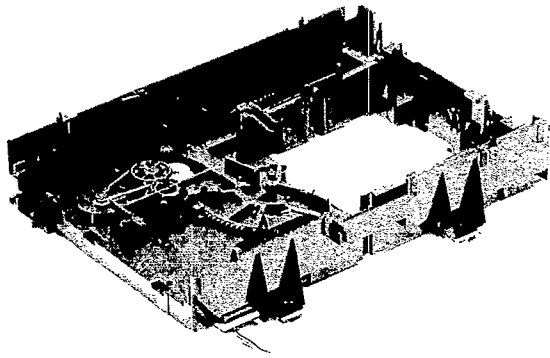

[Back side]

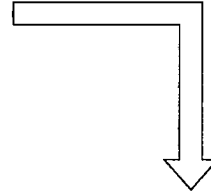
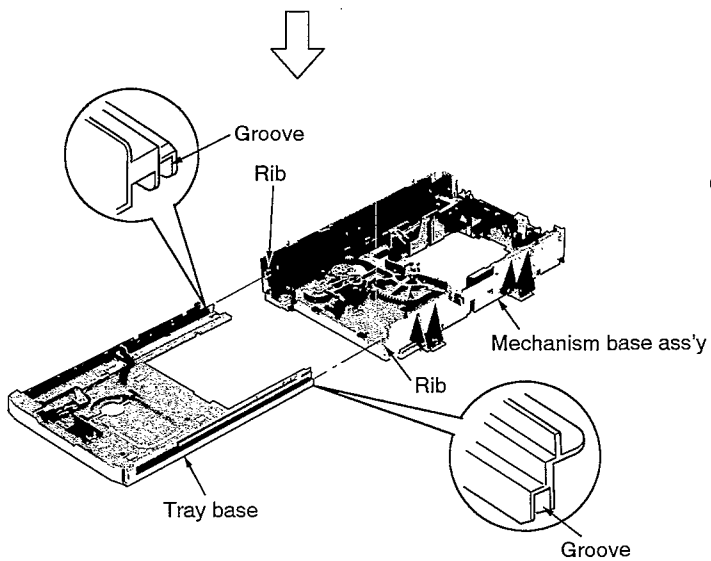
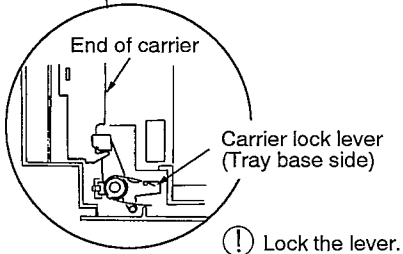
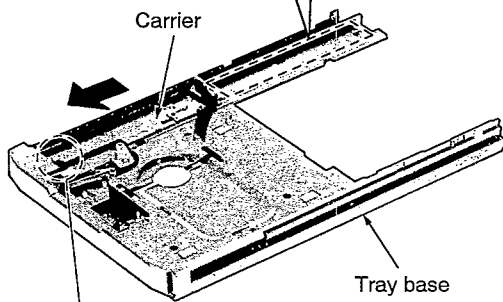
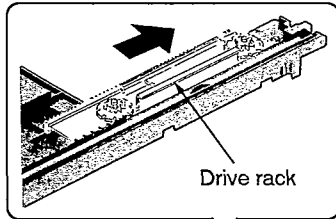

Step 1 Pull the drive rack in the direction of arrow (→) fully.

Step 2 Slide the carrier in the direction of arrow (→).



Step 3 Insert the tray base to the mechanism base ass'y with keeping the procedures **Step 1** and **Step 2**.

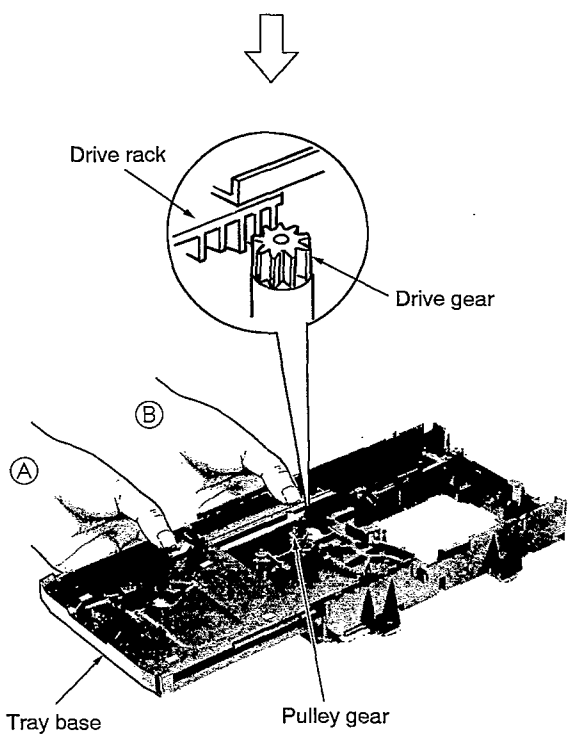

Step 4 ● Insert the drive rack until the driver rack interferes with the drive gear.

Position (A)

Step 5 ● Rotate the pulley gear clockwise gently by hand (5 or 6 times).

⚠ When the gear begins to rotate, rotate the pulley gear with finger pressure (position (B)) because the drive rack gear will fall free.

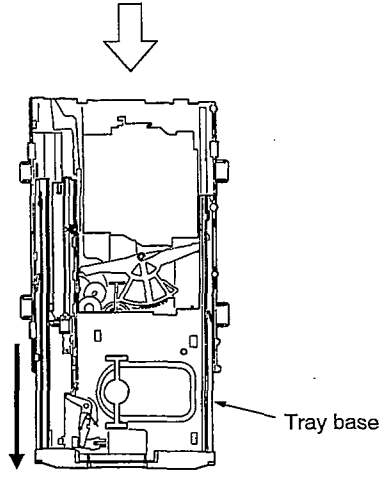

Step 6 Allow the tray base be open manually.

※ Draw the inserted tray base forward.

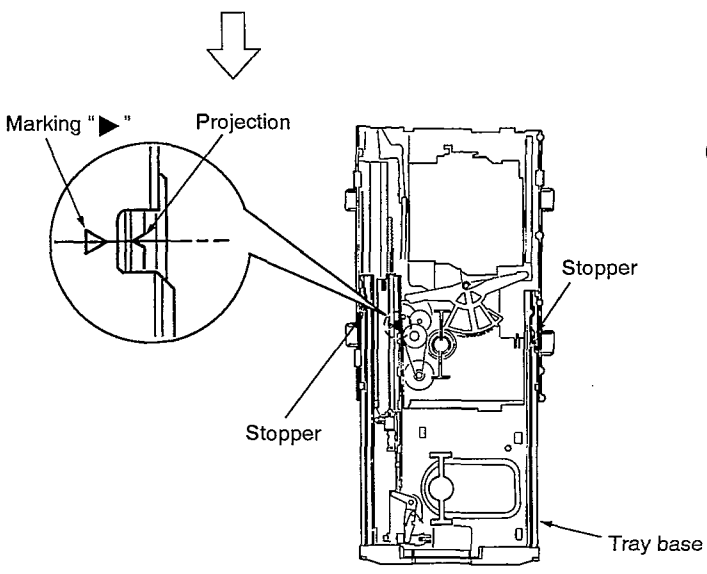

Step 7 Locate the projection at the marking "▶" as shown left.

⚠ In case that the stated above is not operated draw the tray base again. (Refer to item (⚠) on page L-5)

(Retry the item marked with ●)

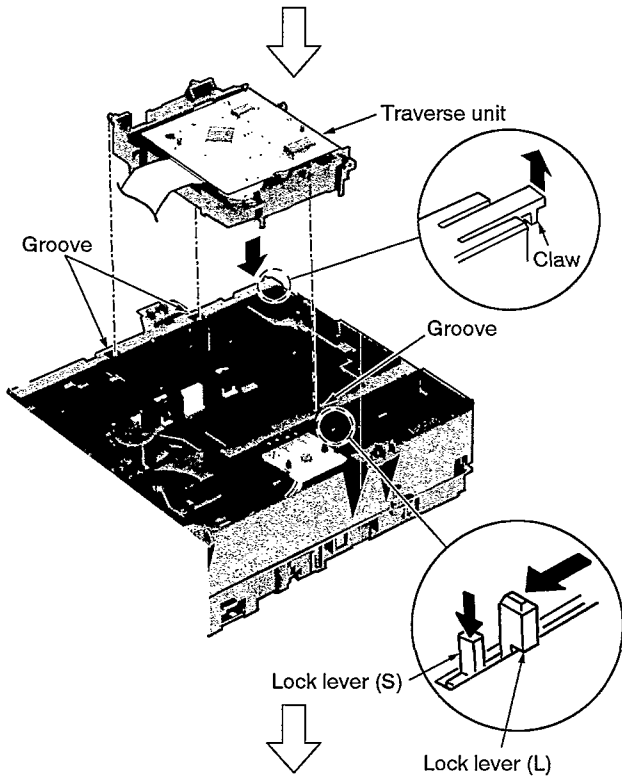

Step 8 While lifting the claw upward, press the lock lever (L) with forcing the lock lever (S).

Step 9 Align the boss of traverse unit with the groove of mechanism base ass'y.

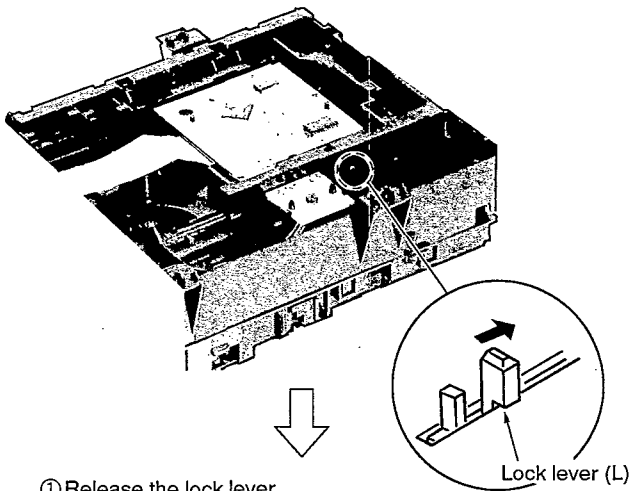

Step 10 Pull the lock lever (L) in the direction of arrow (→).

① Release the lock lever manually.

After assembly, confirm the traverse unit operation.

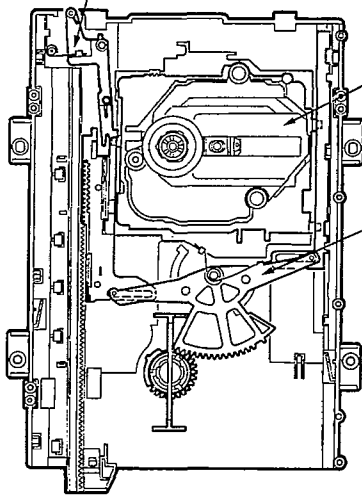

<"DOWN"stated>

② Rotate the conversion lever manually.

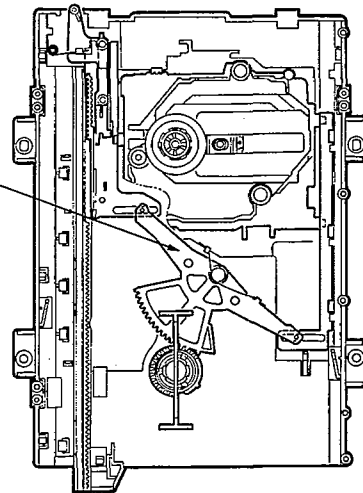

<"UP"stated>

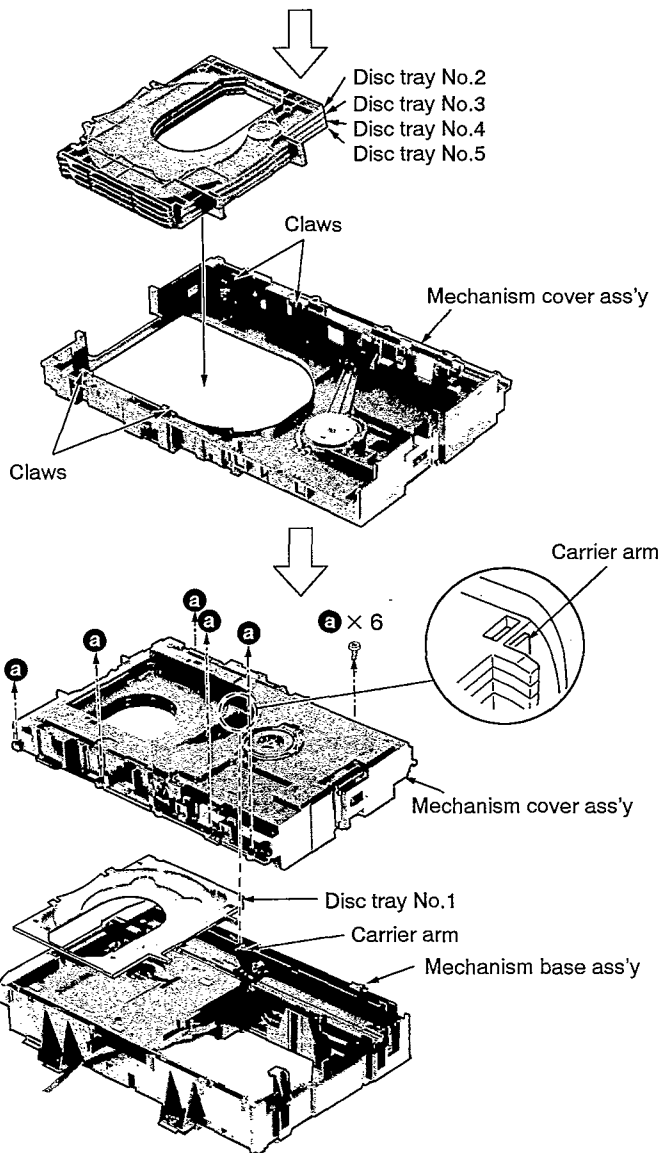

Step 11 Install the 4 disc trays to the mechanism cover ass'y. (Allow them to lock with claws.)

Ⓢ Install the disc trays in specific order. (Disc tray No. is indicated on the tray.)

Step 12 Place the disc tray No.1 on the mechanism base ass'y.

Step 13 Install the mechanism cover ass'y.

Ⓢ The carrier arm is positioned as shown left.

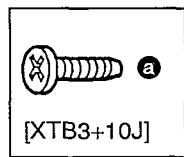

Inspection for CD changer unit

• Begin the inspections in condition that the traverse is kept from disc tray. (5 disc trays in the store compartment.)

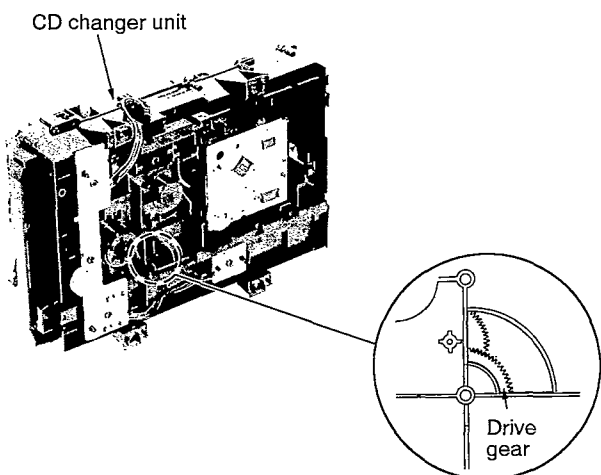

※ Manual operations

- ① Rotate the drive gear counterclockwise manually.
 - The traverse runs over the disc tray, and rises at maximum level.
- ② Rotate the drive gear clockwise manually.
 - The disc tray moves and is stored in upper compartment.
 - The tray base is open.
- ③ Again rotate the drive gear counterclockwise manually.
 - The tray base is closed, and then it returns to start position.

Main Component Replacement Procedures

Checking for the main P.C.B. and the operation P.C.B.

Perform the items **Step 1** and **Step 2** for CD changer removal.
(Refer to page 5.)

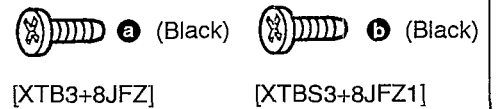
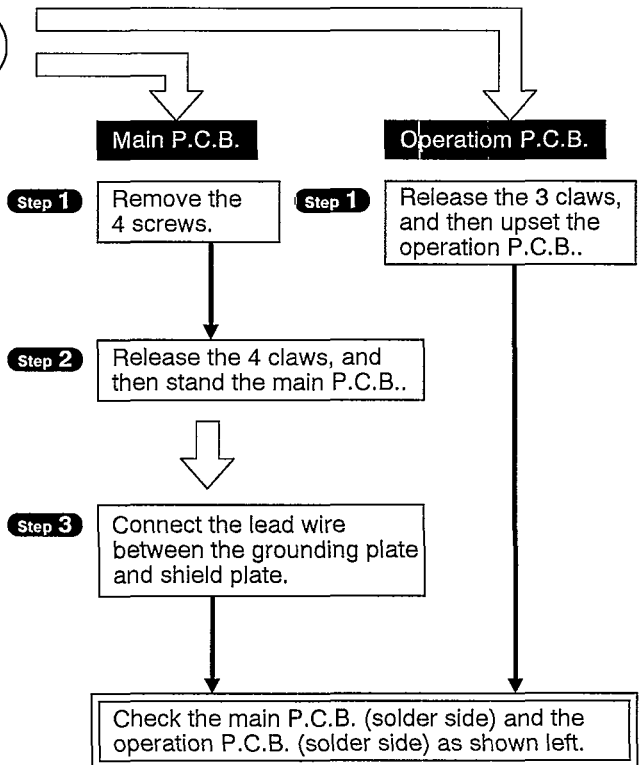
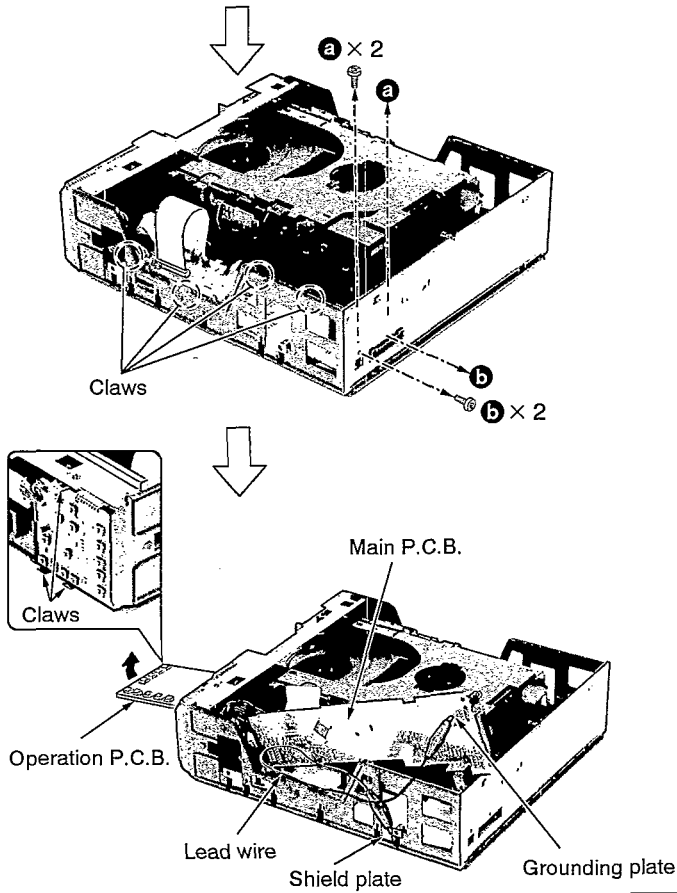

Checking for the servo P.C.B.

Perform the items **Step 1** ~ **Step 6** for CD changer removal.
(Refer to pages 5 and 6.)

Perform the items **Step 1** ~ **Step 4** for traverse unit removal.
(Refer to page 6.)

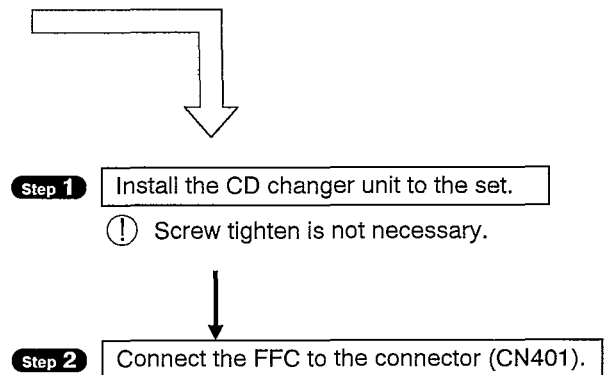
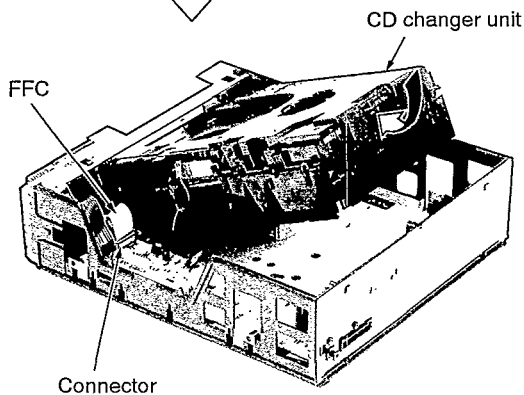

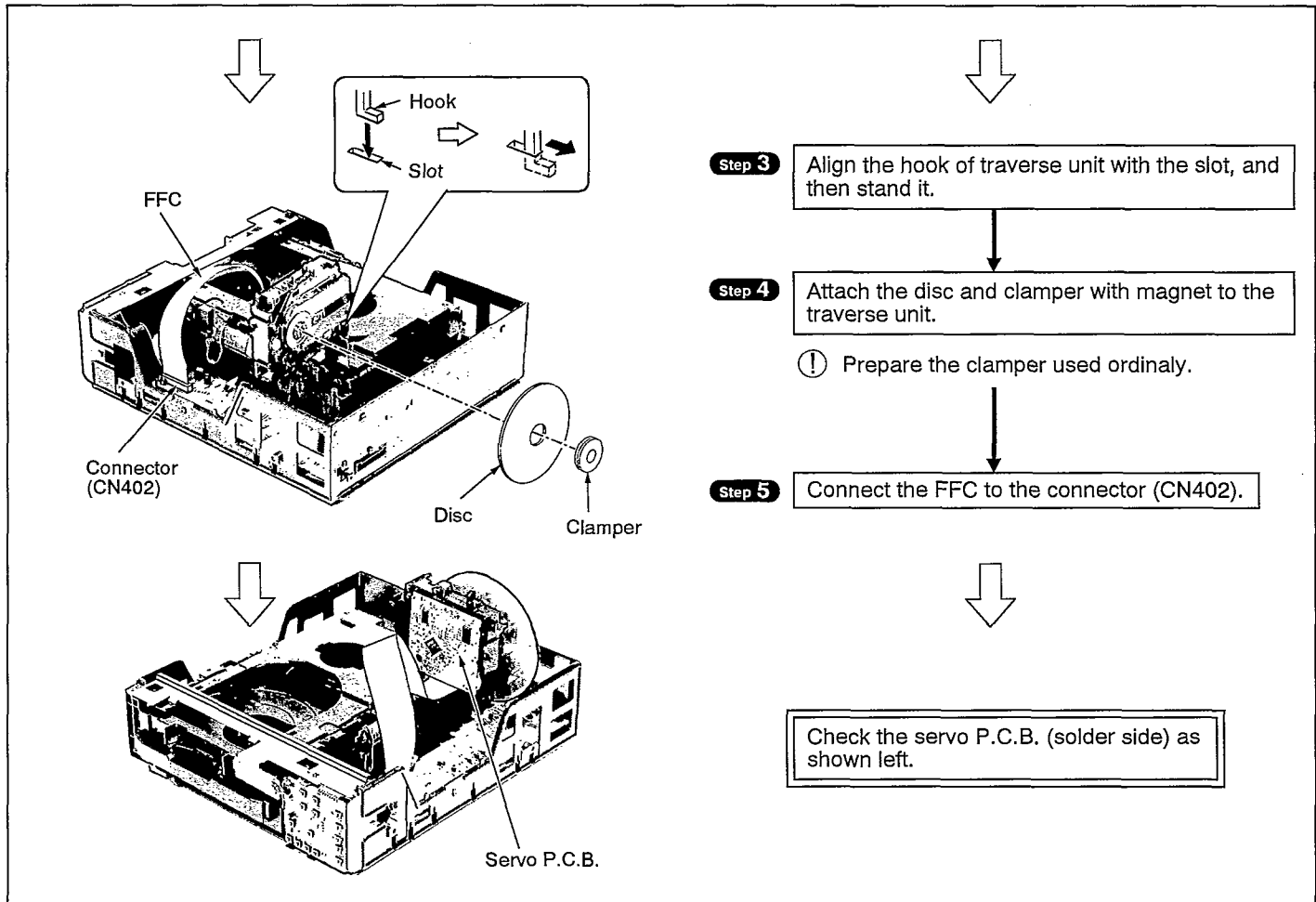

Main Component Replacement Procedures

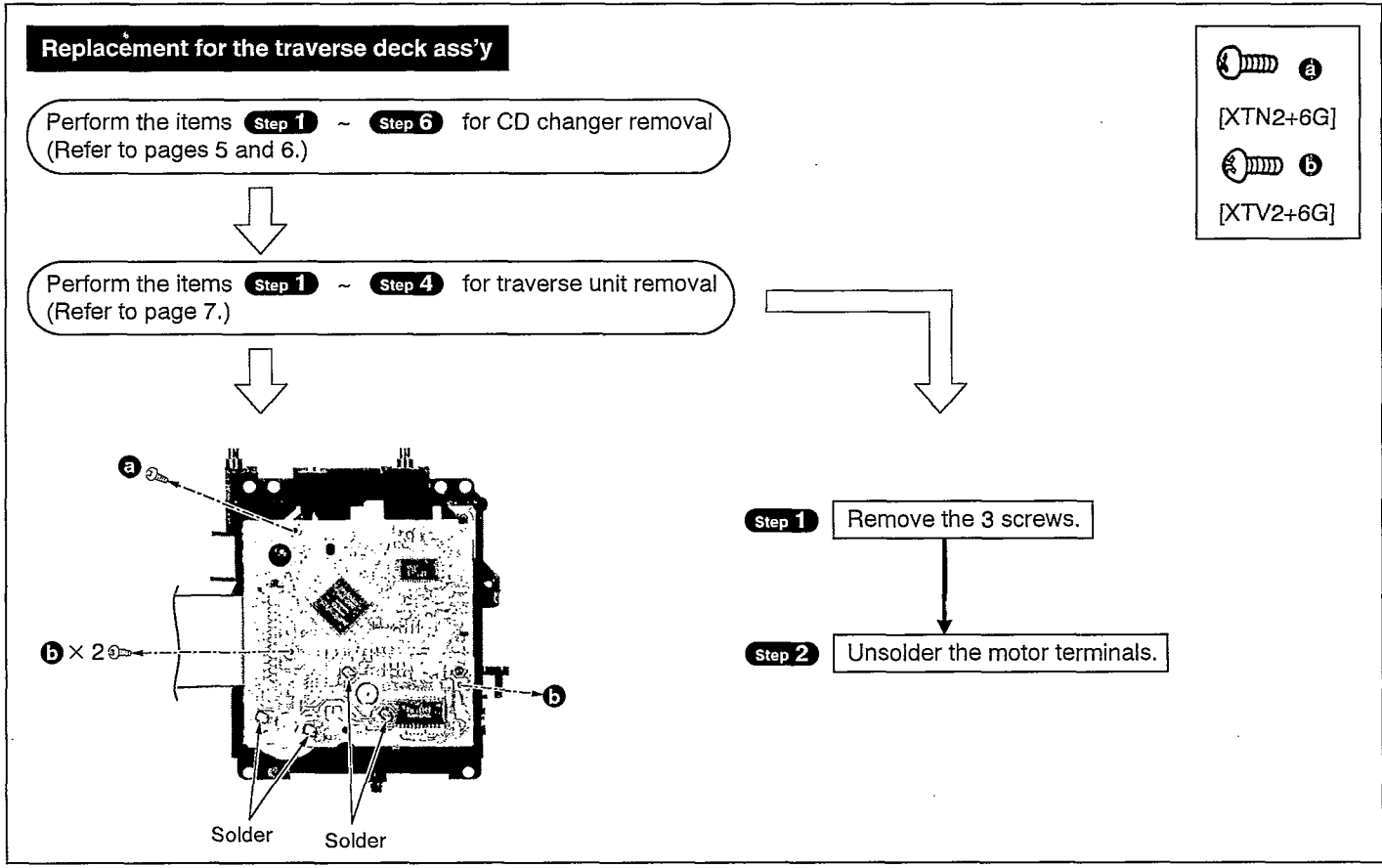

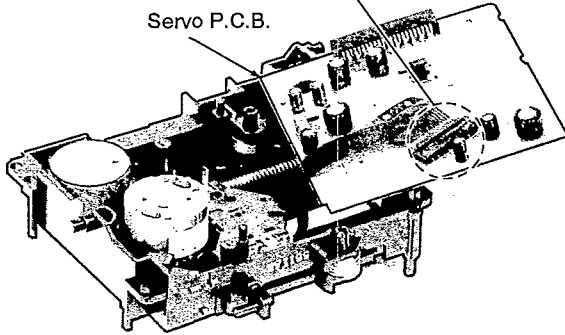
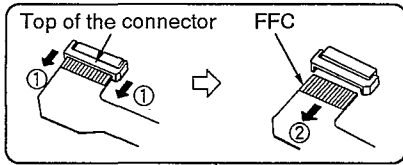

Step 3 Remove the FFC from the connector, and then remove the servo P.C.B..

ⓘ Solder the point between pin 4 (LD) and pin 5 (GND) of FFC. (Refer to "Handling Precautions for Traverse Deck" on page 4).

1. Spread the boss with ⊖ screwdriver. 2. Pull out the pin in the direction of arrow.

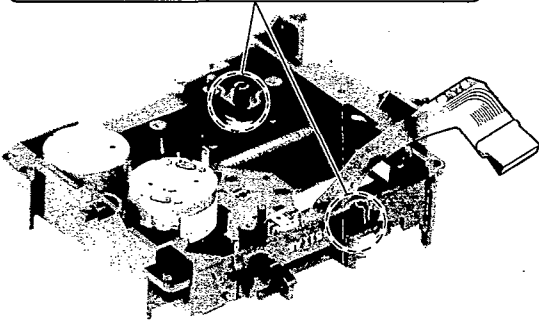
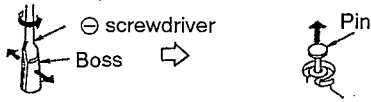

Step 4 Remove the pins.

Traverse deck ass'y [RAE0150Z]

Floating spring (1)

Floating spring (1)

Floating spring (2)

Claw

Step 5 Release the claws, and then remove the traverse deck ass'y.

ⓘ Be careful not to lose the 3 springs because those will also be removed on removal of the traverse deck ass'y.

Installation of the servo P.C.B.

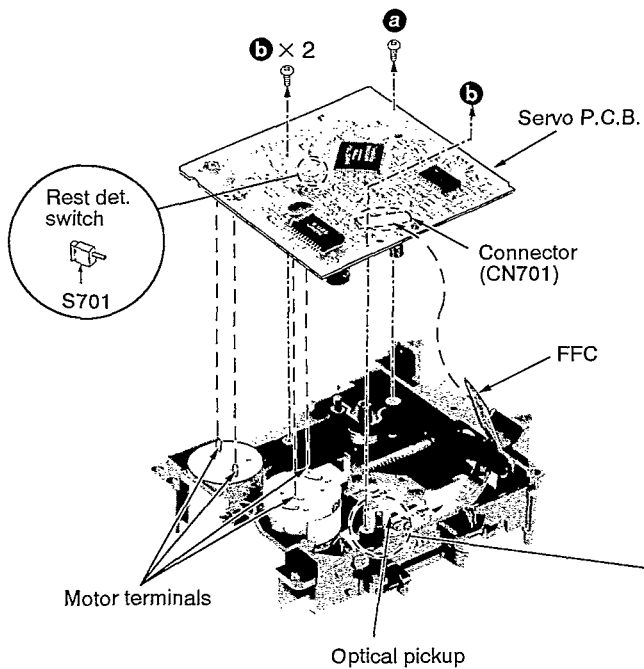

Step 1 Before installing the servo P.C.B., move the optical pickup toward the outer edge from mark "▼".

⚠ In case that the optical pickup is not moved toward the outer edge from the marking, the rest detect switch (S701) mounted on the servo P.C.B. may be damaged.

Step 2 Connect the FFC to the connector.

Step 3 Install the servo P.C.B., and then tighten screws.

⚠ After tightening screws, solder each motor terminal.

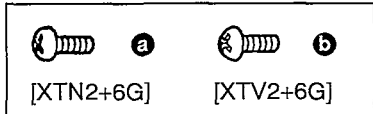
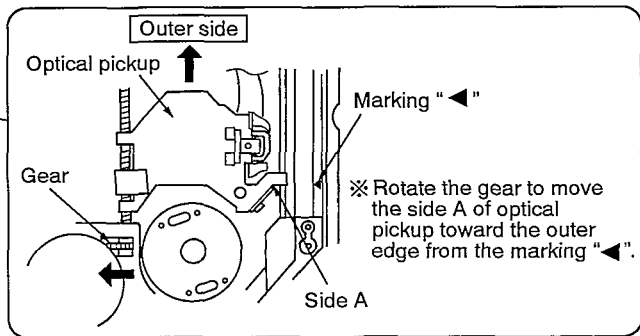

■ ERROR CODE DISPLAY AND SERVO ADJUSTMENT FUNCTION

This unit has an error code display function, so that if the unit operates incorrectly, the fault is displayed using an error code on the FL display of the tuner (ST-CA10). It also has a servo adjustment function for displaying the status of servo system functions (focus, tracking, CLV) on the tuner's FL display.

The system control IC and FL display are part of the tuner so make sure the system has been connected properly before using these functions. (This unit can be operated independently, although the error code display and servo adjustment functions cannot be used.)

Use these two functions for guidance during fault diagnosis and repair.

Note: Check beforehand for scratching or soiling of the test disc (SZZP1054C), and soiling or other problems with the optical pickup lens.

● Error code display procedure

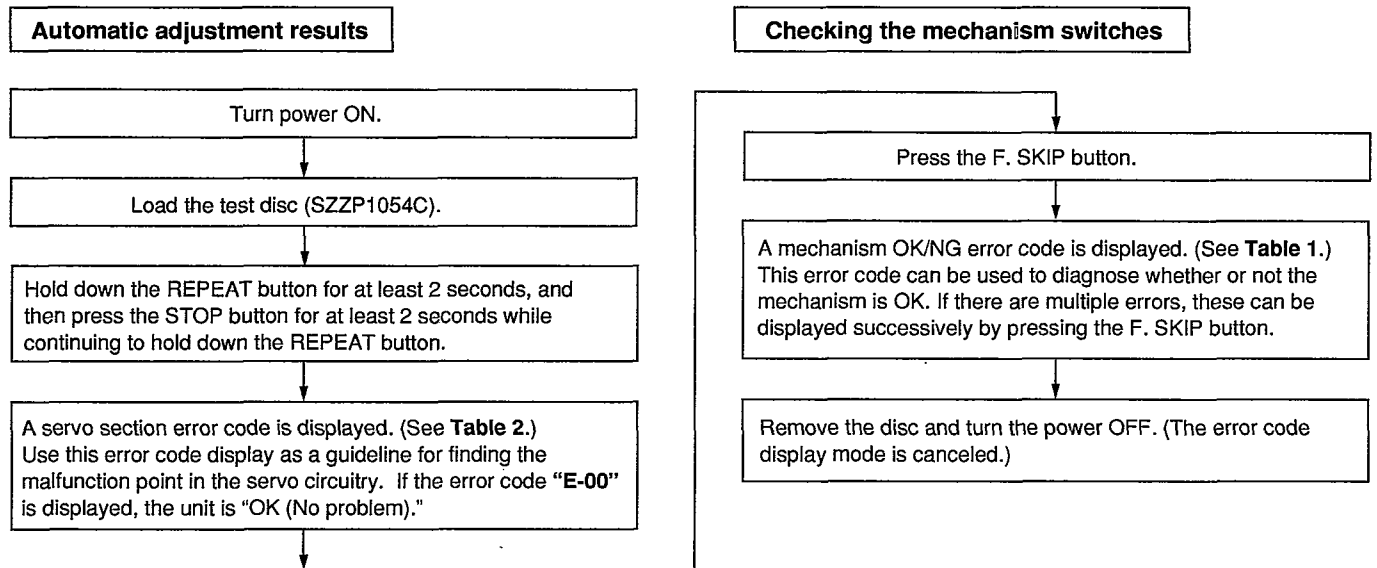

● Servo adjustment procedure

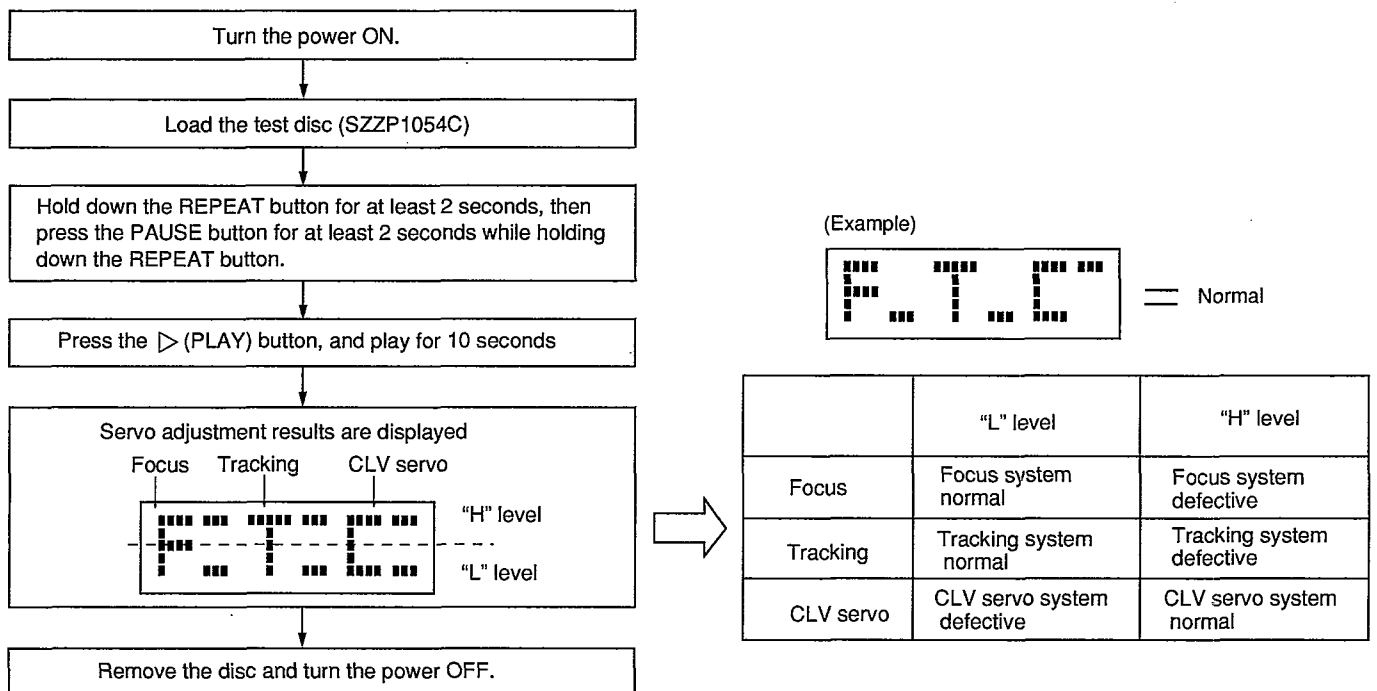







● Table 1

FL display	Symptom	Cause
H - 15	When CD tray opens, it closes by itself.	Disc tray "Open" detection switch (S4) fault.
H - 16	When CD tray closes, it opens by itself	Disc tray "Closed" detection switch (S4) fault.
F - 15	Does not play, even when CD play button is pressed.	Pickup rest position detection switch (S701) fault.
F - 16	Traverse pushes up disc tray.	Up position detection switch (S3) fault.
F - 26	Does not move even when "▷" (PLAY) is pressed.	System control or servo processor IC (IC401, 702) fault.
F - 27	Tray keeps moving for a while, or selected tray does not open.	Disc number detection switch (S5) fault.
F - 28		Stocker position detection, or play position detection switch (S1, S2) fault.
F - 75	"NO DISC" is displayed and unit does not play, even when a CD is loaded.	CD circuit power supply problem.

● Table 2

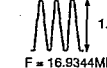
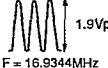
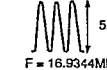
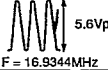
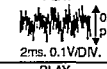
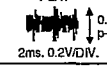
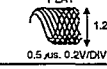
※ The unit is satisfactory if the error code is E - 00 of E - 02

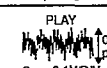
※ Before testing, check that the test disc is free of scratches and optical pickup is clean.

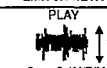
FL error code display	Symptom	Probable cause	Signal to check		Normal voltage and waveform values	
			Signal name	Location	PLAY	STOP
E - 01	Focus and tracking offset adjustments not completed in the specified time period.	1. Clocks X1 and X2, power supply V _{DD} and reset/RST, all on IC702. 2. MDATA, MCLK, MLD and SENSE signal to/from mechanism controller.	MDATA	IC702 (8) pin		0V
			MCLK	IC702 (7) pin		4.8V
			MLD	IC702 (9) pin		
			SENSE	IC702 (10) pin	0V	0V
			/RST	IC702 (18) pin	4.9V	4.9V
			X1	IC702 (58) pin		
			X2	IC702 (59) pin		
E - 03 E - 05 E - 07 E - 09 E - 0B E - 0D E - 0F	Disc play unstable.	1. Scratches or contaminants on disc surface. 2. Focus and tracking servo circuits (check waveforms, voltages, and part values.) 3. Spindle driver circuit. 4. Optical pickup.	FE	IC702 (32) pin		2.5V
			TE	IC702 (33) pin		2.5V
			FOD	IC702 (28) pin	2.5V	2.5V
			TRD	IC702 (27) pin	2.5V	2.5V
			KICK	IC702 (26) pin	2.5V	2.5V
			/FLOCK	IC702 (11) pin	0V	4.9V
			/RF DET	IC702 (38) pin	0V	4.9V
			RF	TJ701		3.4V
			STAT	IC702 (17) pin	4.9V	0V
			E - 04 E - 06 E - 0C E - 0E	Best "Eye" (PD Balance) adjustment not completed in the specified time period.	1. Scratches or contaminants on disc surface. 2. Focus and Tracking servo circuit (check waveforms, voltages, and part values.) 3. Optical pickup.	FBAL
RF	TJ701					3.4V
FE	IC702 (32) pin					2.5V
/TLOCK	IC702 (12) pin	0V				0V
OFT	IC702 (36) pin	0V				0V
E - 08 E - 0A	Focus or Tracking gain adjustment not completed in the specified time period.	1. Scratches or contaminants on disc surface. 2. Focus and Tracking servo circuit (check waveforms, voltages, and part values.) 3. Optical pickup.	FE	IC702 (32) pin		2.5V
			TE	IC702 (33) pin		2.5V
			/TLOCK	IC702 (12) pin	0V	0V
			OFT	IC702 (36) pin	0V	0V

MEASUREMENTS AND ADJUSTMENTS

Cautions:

- It is very dangerous to look at or touch the laser beam. (Laser radiation is invisible.)
With the unit turned "on", laser radiation is emitted from the pickup lens.
- Avoid exposure to the laser beam, especially when performing adjustments.

This unit SL-CA10 is designed to operate on power supplied from the Amplifier SE-CA10 through the Tuner ST-CA10.

When connecting the unit to other system components, do not connect to the Amplifier SE-CA10 directly. Be sure to connect this unit through the Tuner ST-CA10.

When operating the unit SL-CA10 alone for testing and servicing, without having power supplied from the Amplifier SE-CA10 and the Tuner ST-CA10, use the following method.

Power Supply to This Unit alone

1. Short-circuit the section between jumper (J13) and jumper (J14) [**TEST MODE**].
2. Apply 11V AC power to the section between **AC** of the coil (L1) and the jumper (J3) **GND** as well as the section between **AC** of the coil (L2) and the jumper (J3) **GND**. (Shown in Fig. 1)

Operating the Unit Alone

When this unit is operated, alone without system connection to other units, the switches on the front panel remain inoperative. To operate the switches, follow the procedure below.

1. Short-circuit the points between the jumper (J11), the jumper (J12) and the [**REF-M**].
2. Short-circuit the points between the jumper (J15), the jumper (J16) and the [**KEY2**].

To Check Signals

Connect the oscilloscope or the speaker with built-in amplifier to the section between LINE OUT (Lch) of the resistor R447 and the GND point of the jumper (J3) as well as the section between LINE OUT (R ch) of the resistor R448 and the GND point of the jumper (J3) and check if the signals are outputting from this unit. (Shown in Fig. 1)

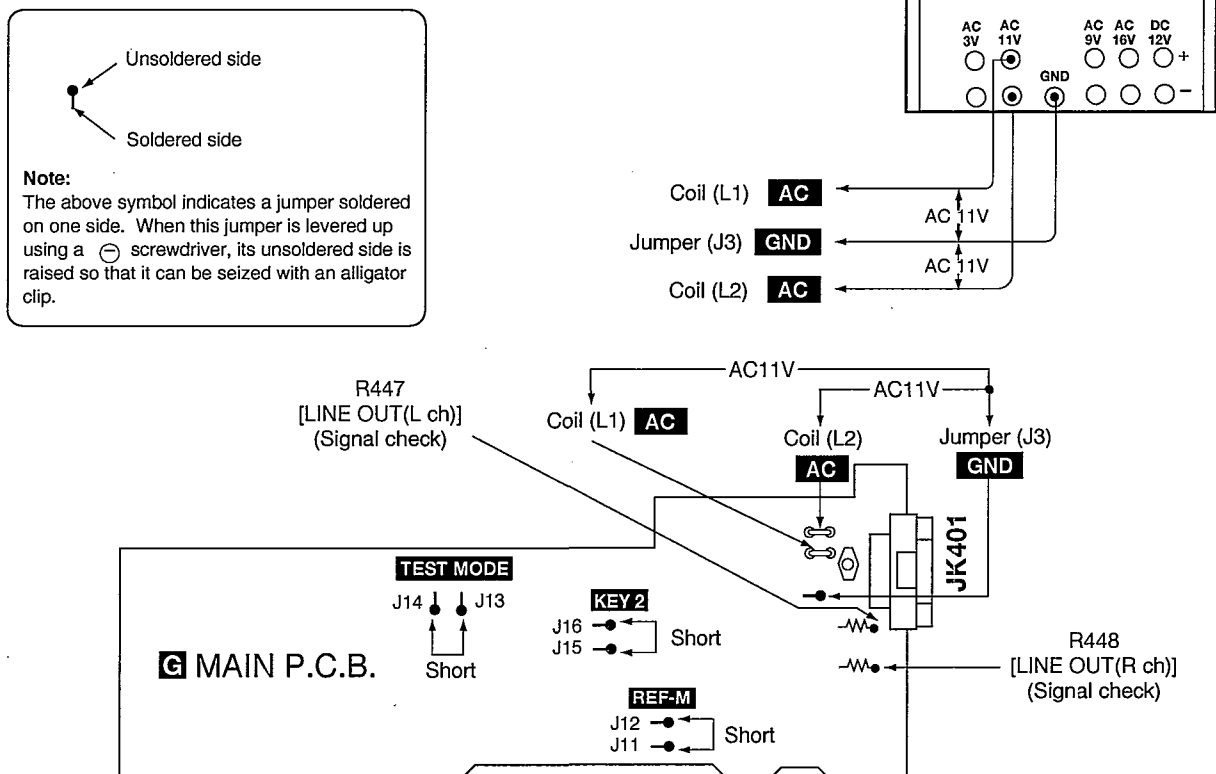
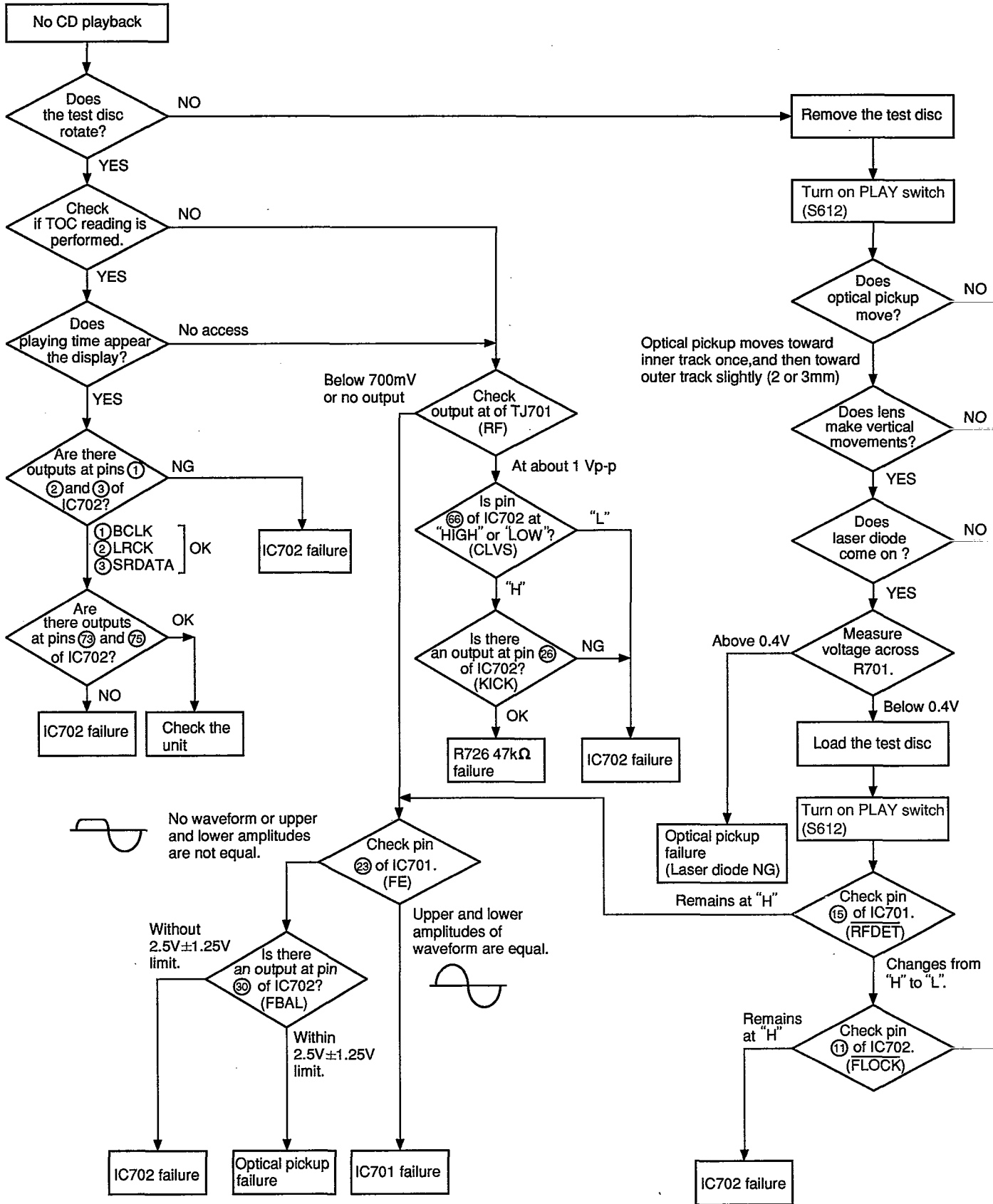
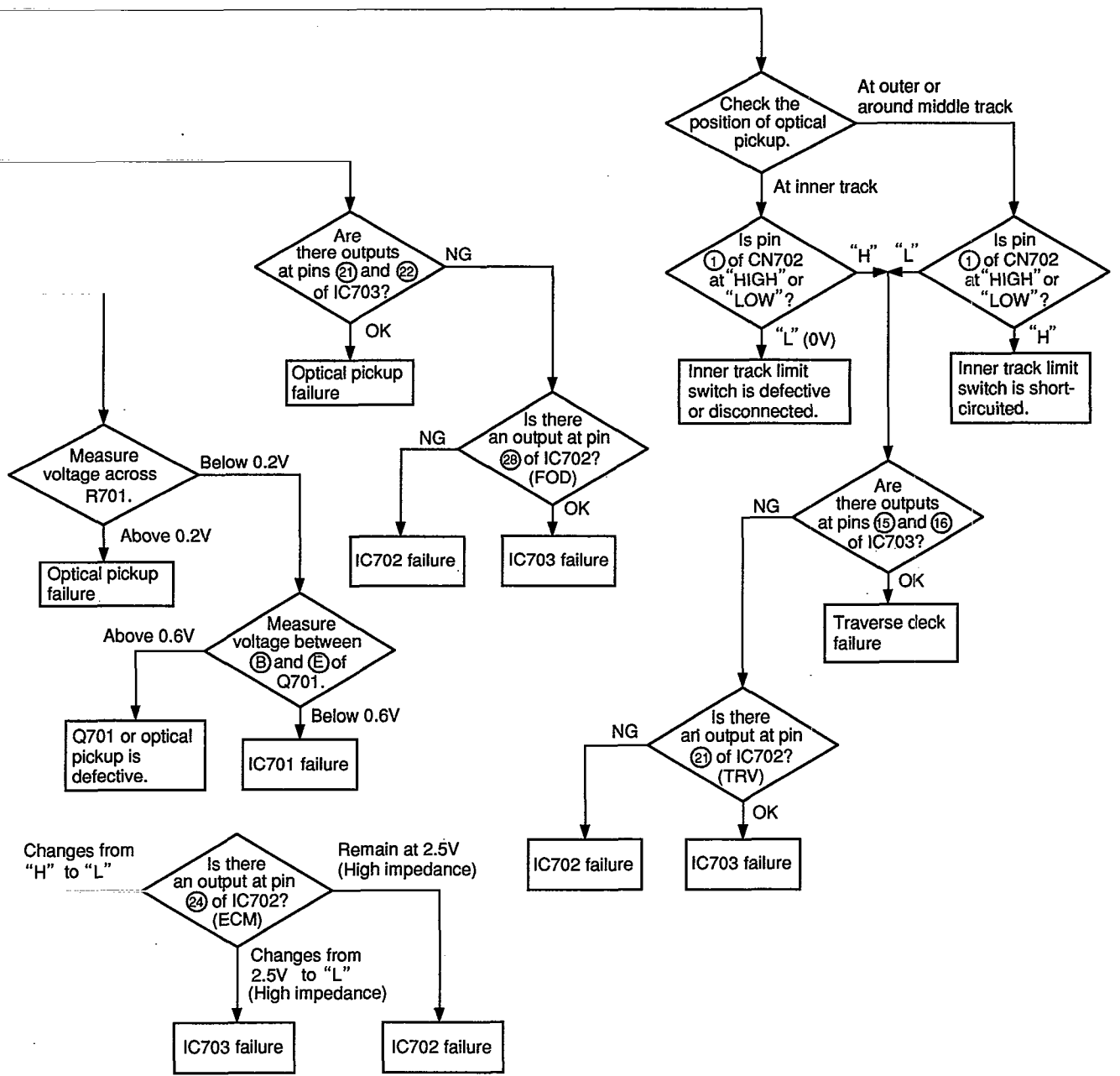

Fig. 1

■ TROUBLE SHOOTING (SERVO CIRCUIT)





BLOCK DIAGRAM

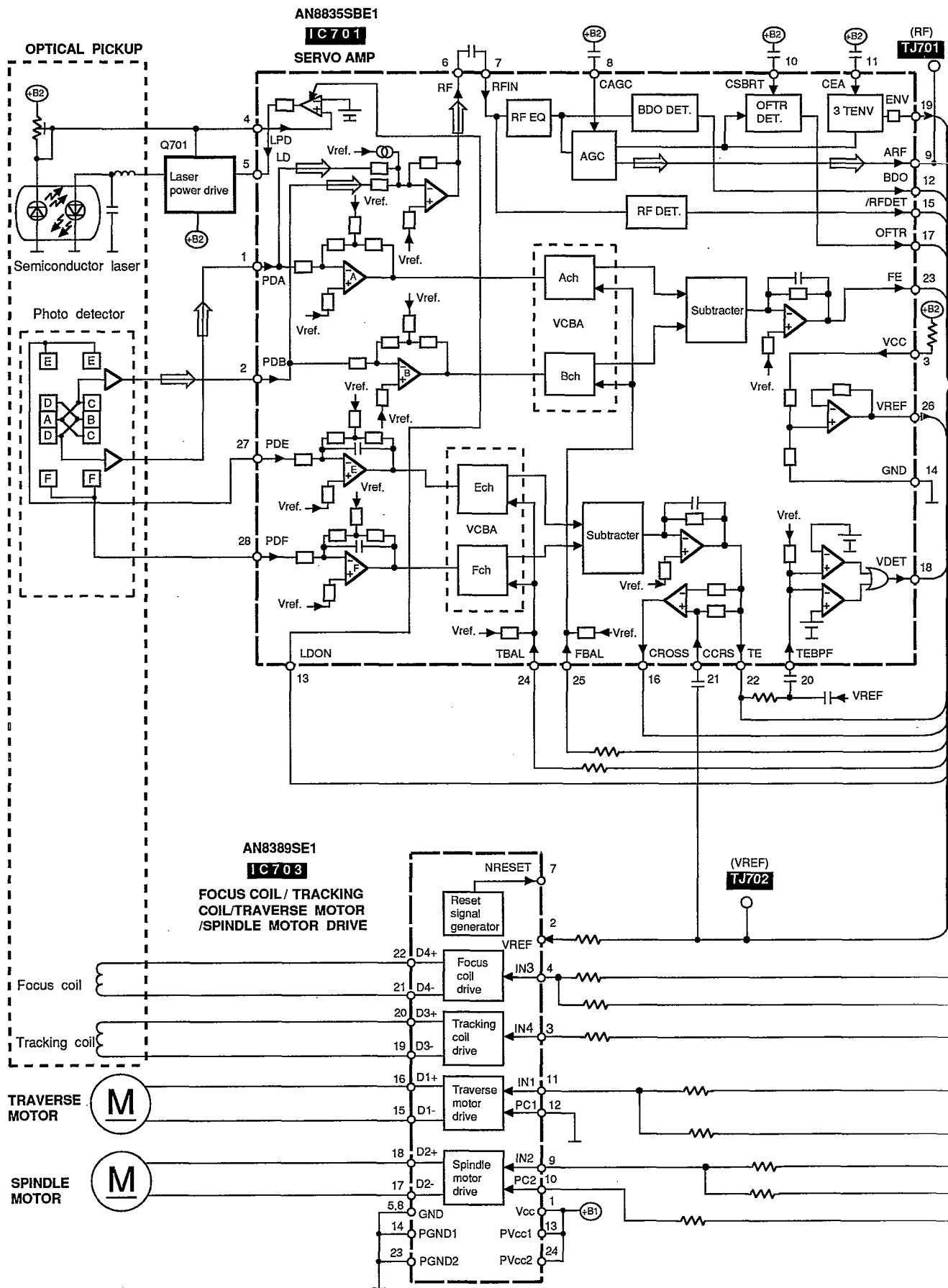

● Signal line ⇨ : CD signal

MN662740RM1

IC702

SERVO PROCESSOR/DIGITAL SIGNAL PROCESSOR/
DIGITAL FILTER / D/A CONVERTER

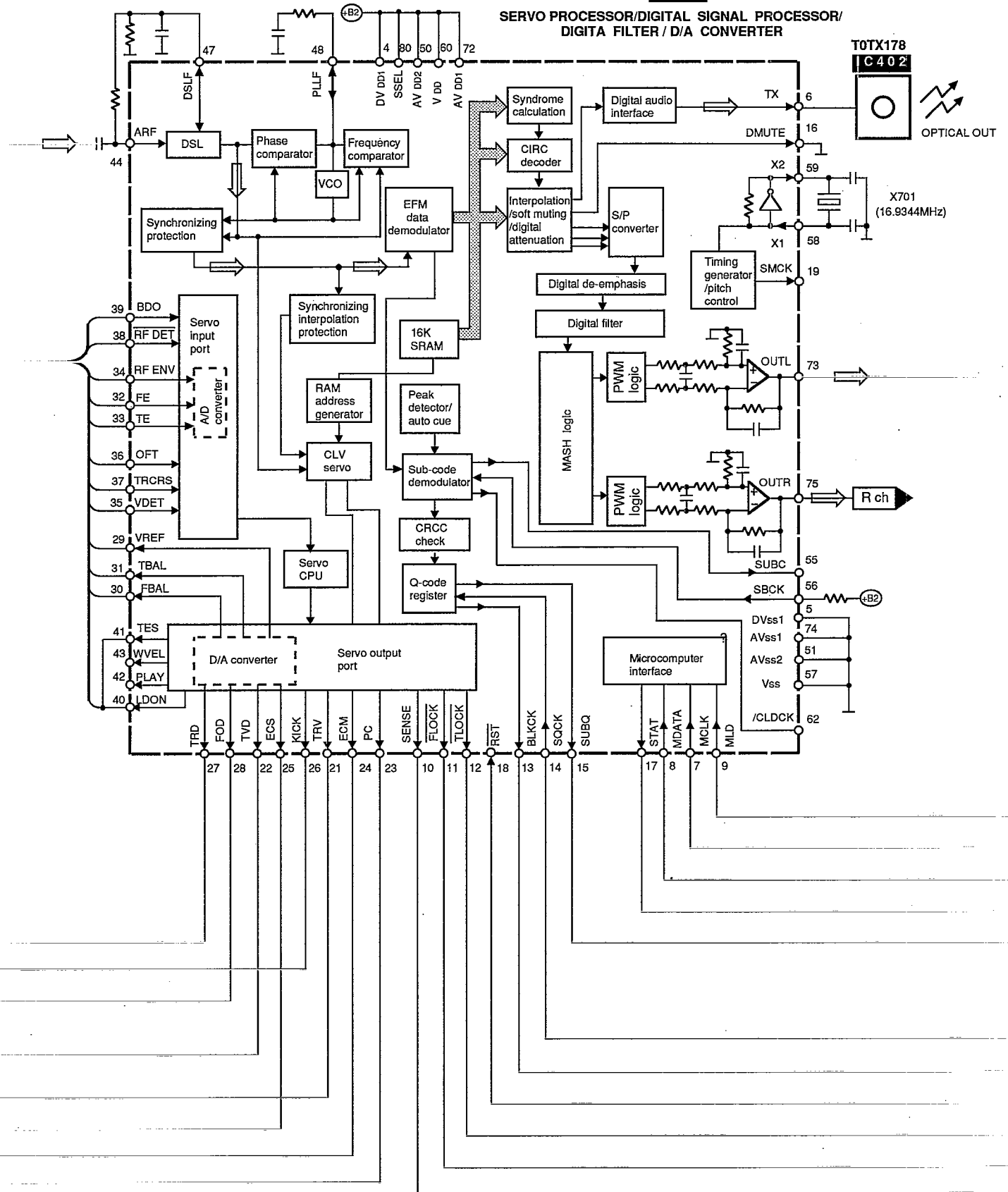

● Signal line ⇨ : CD signal

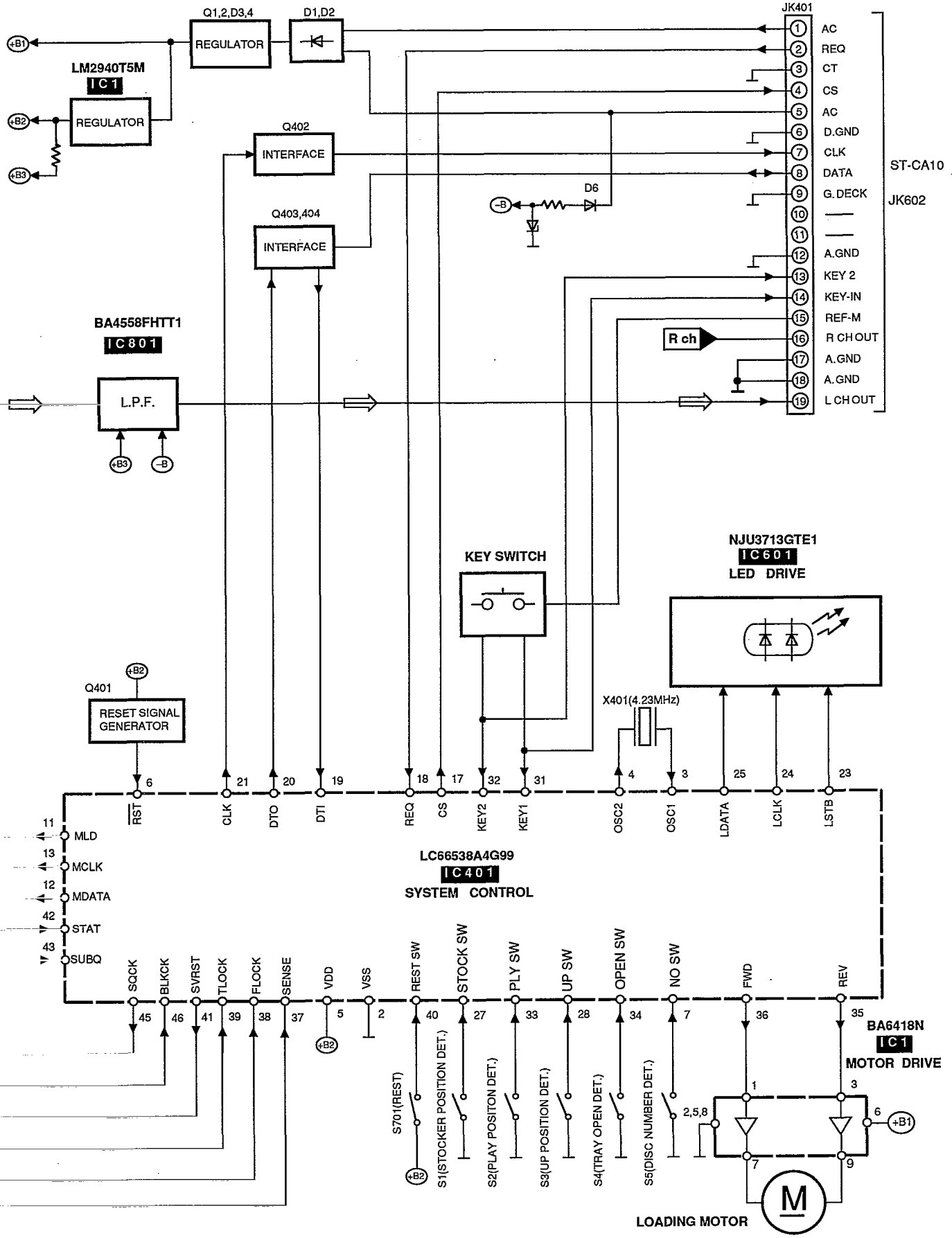

■ SCHEMATIC DIAGRAM (Parts list on pages 37, 38, 41, 42.)

- This schematic diagram may be modified at any time with the development of new technology.

	Page		Page
A SERVO CIRCUIT	26, 27	E LOADING MOTOR CIRCUIT	28
B SWITCH CIRCUIT	28	F OPERATION CIRCUIT	28
C SWITCH (S2, S3) CIRCUIT	28	G MAIN CIRCUIT	28, 29
D LED CIRCUIT	28		

Notes:

- **S1** : Stocker position detect switch
- **S2** : Play position detect switch
- **S3** : Up position detect switch
- **S4** : Tray open detect switch
- **S5** : Disc number detect switch
- **S601~S605**: Disc select switch (DISC) [S601: DISC 5, S602: DISC 4, S603: DISC 3, S604: DISC 2, S605: DISC 1]
- **S606**: Disc check switch (DISC CHECK)
- **S607**: Repeat switch (REPEAT)
- **S608**: AI edit switch (AI EDIT)
- **S609**: Random play switch (RANDOM)
- **S610**: R. skip/ search switch (◀◀/◀◀)
- **S611**: Stop switch (□)
- **S612**: Play switch (▷)
- **S613**: F. skip/ search switch (▶▶/▶▶)
- **S614**: Pause switch: (■)
- **S615**: Disc tray open/close switch (▲ OPEN/CLOSE)
- **S701**: Rest detect switch
- Indicated voltage values are the standard values for the unit measured by the DC electronic circuit tester (high-impedance) with the chassis taken as standard. Therefore, there may exist some errors in the voltage values, depending on the internal impedance of the DC circuit tester.

No mark: CD STOP

(): CD play [1kHz, L+R, 0dB]

- Important safety notice:
Components identified by  mark have special characteristics important for safety. Furthermore, special parts which have purpose of fire-retardant (resistors), high-quality sound (capacitors), low-noise (resistors), etc. are used. When replacing any of components, be sure to use only manufacture's specified parts shown in the parts list.
- Caution!
IC and LSI are sensitive to static electricity.
Secondary trouble can be prevented by taking care during repair.
Cover the parts boxes made of plastics with aluminum foil.
Ground the soldering iron.
Put a conductive mat on the work table.
Do not touch the legs of IC or LSI with the fingers directly.

- Voltage and signal line

 : Positive voltage line

 : Negative voltage line

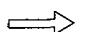
 : CD signal line

A SERVO CIRCUIT
(P.C.Board : on page 30)

**OPTICAL PICKUP
△ CIRCUIT**

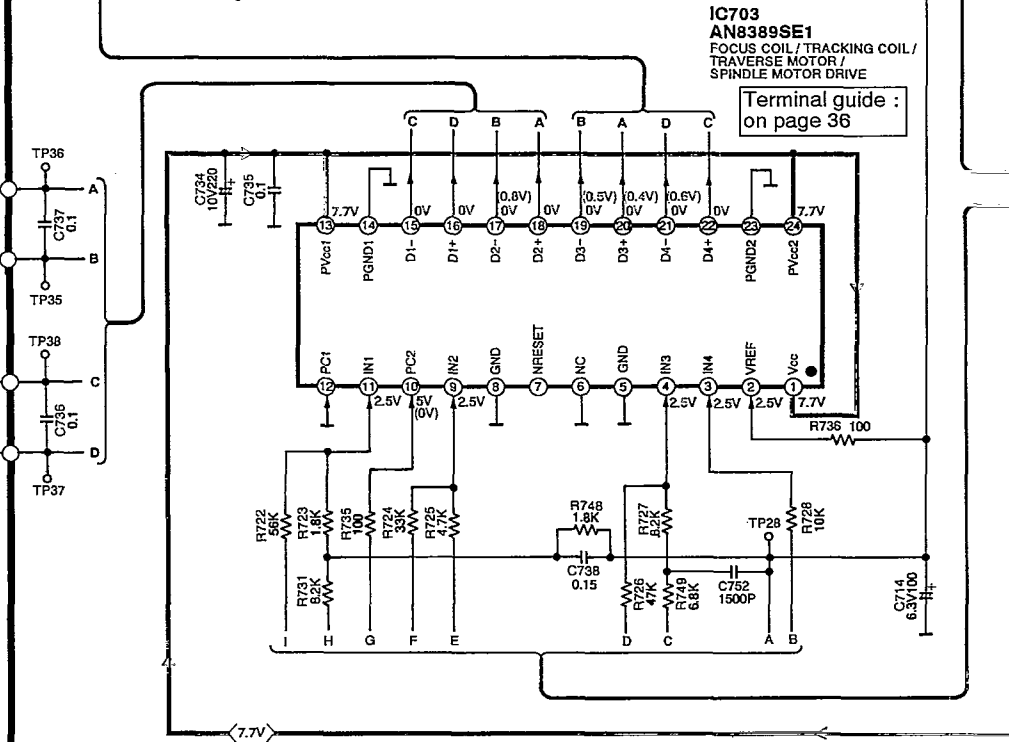
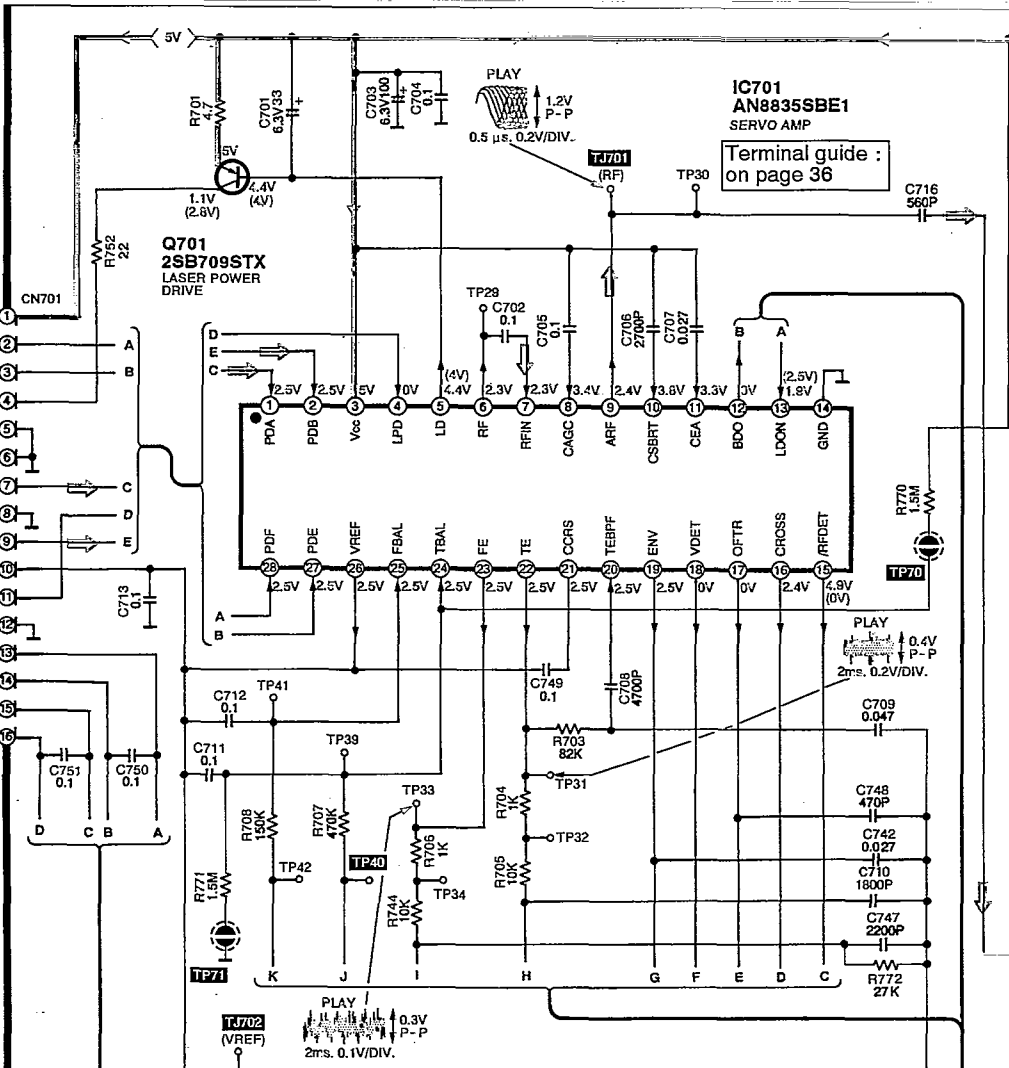
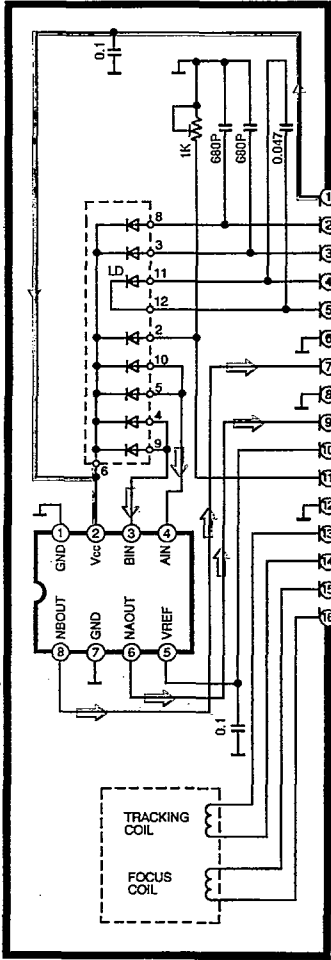

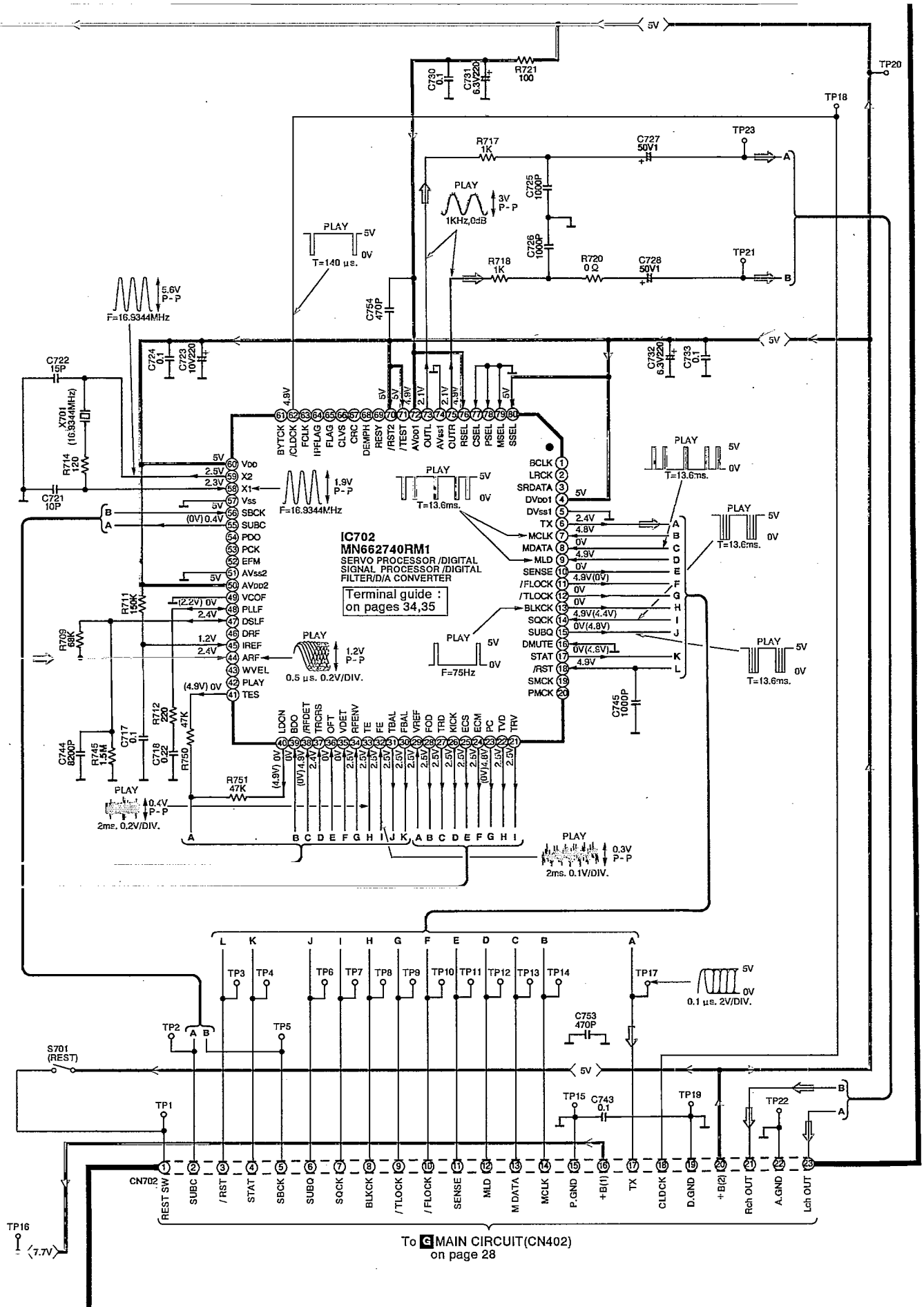

B SWITCH CIRCUIT
(P.C.Board : on page 30)

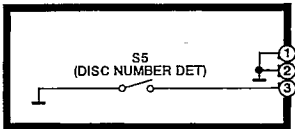

C SWITCH(S2,S3) CIRCUIT
(P.C.Board : on page 30)

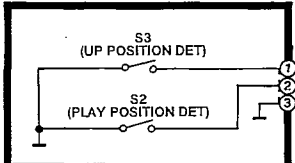

D LED CIRCUIT
(P.C.Board : on page 31)

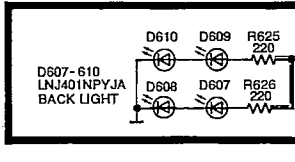

E LOADING MOTOR CIRCUIT
(P.C.Board : on page 30)

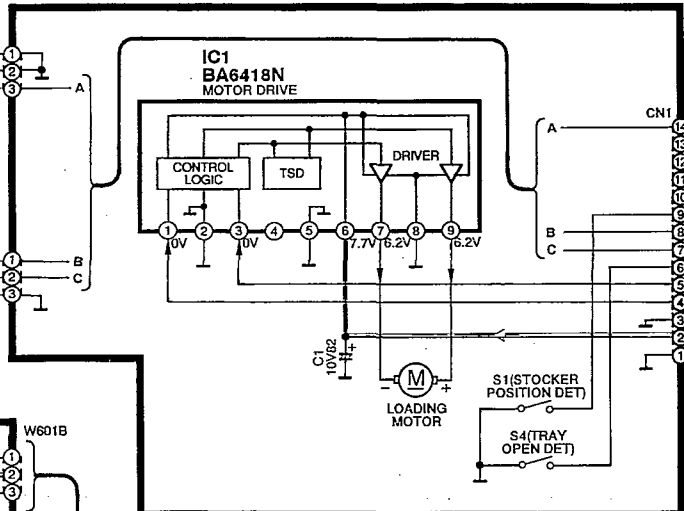

G MAIN CIRCUIT
(P.C.Board : on page 31)

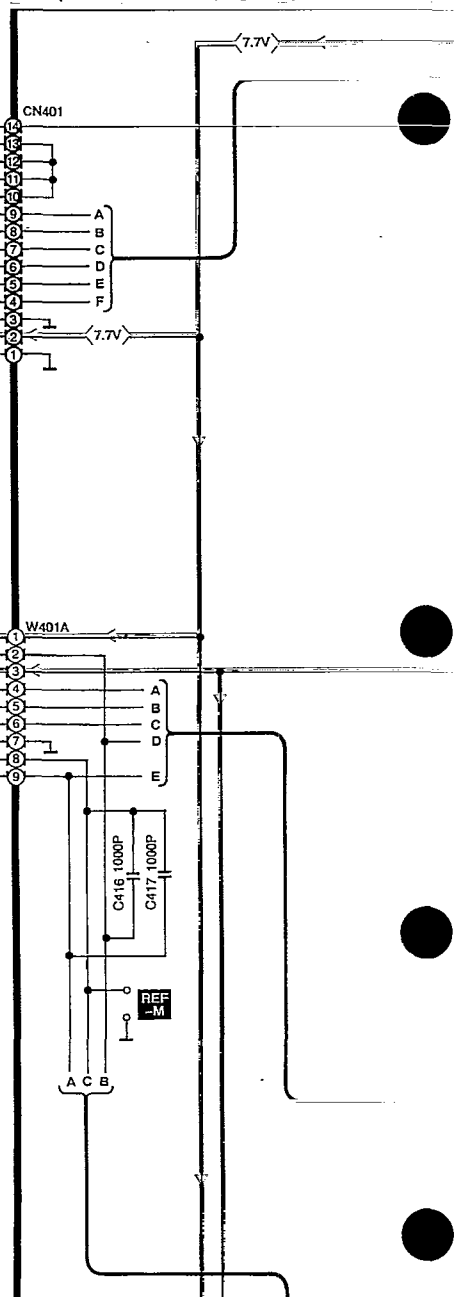

F OPERATION CIRCUIT
(P.C.Board : on page 31)

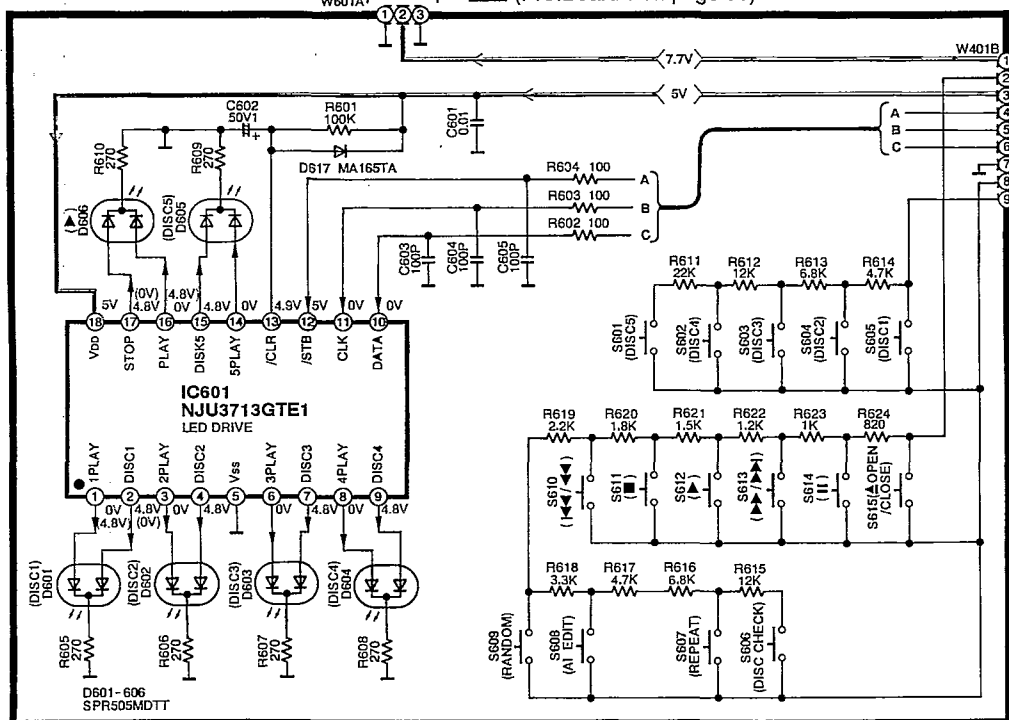

To **A SERVO CIRCUIT**
(CN702)
on page 27

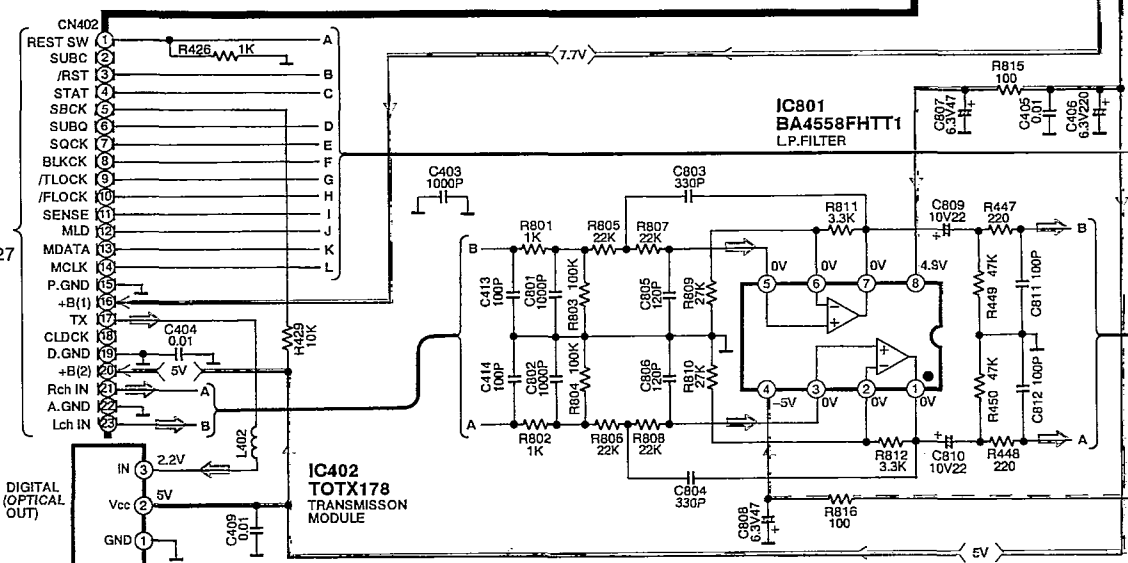

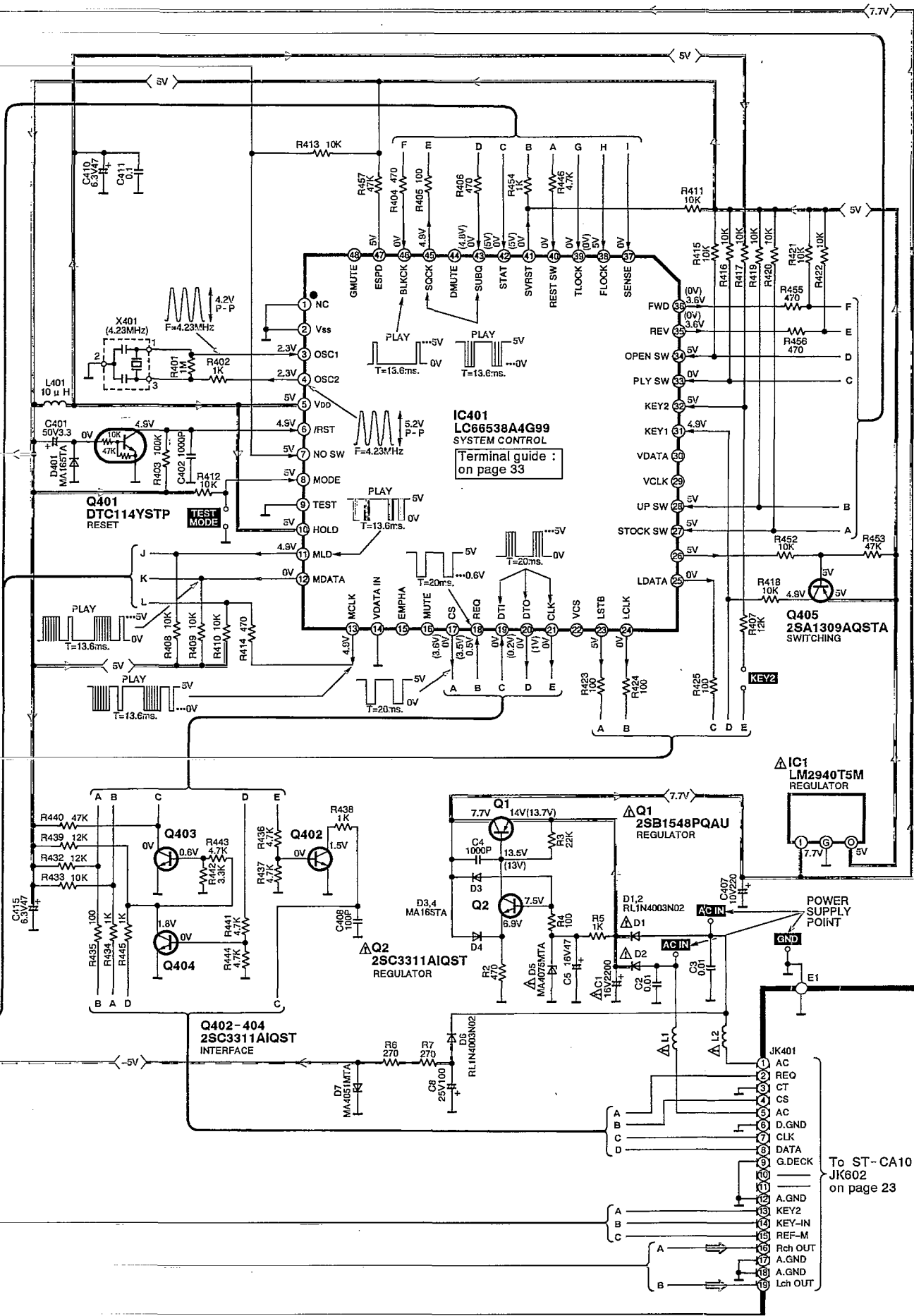

IC401
LC66538A4G99
SYSTEM CONTROL
 Terminal guide :
 on page 33

IC1
LM2940T5M
REGULATOR

To ST-CA10 :
JK602
 on page 23

PRINTED CIRCUIT BOARD DIAGRAM

• This printed circuit board diagram may be modified at any time with the development of new technology.

A SERVO P.C.B. (REP2144B-N)

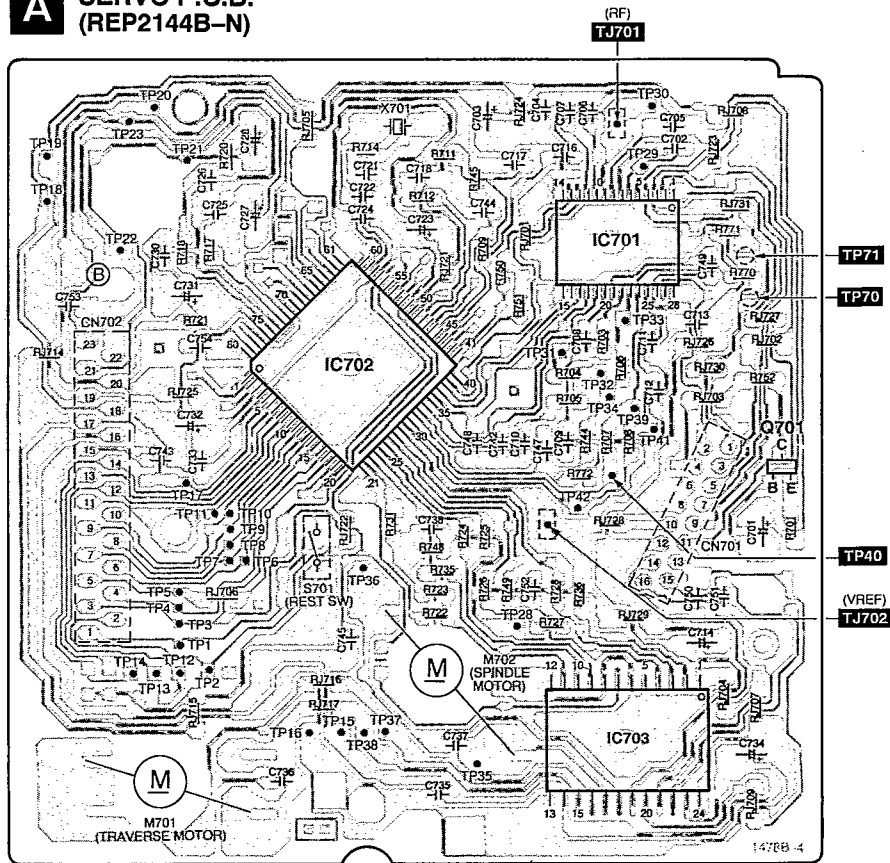

B SWITCH P.C.B. (REP2182A-N)

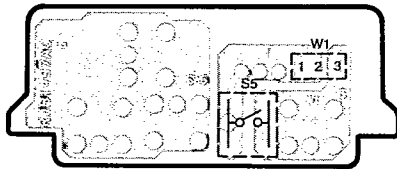

C SWITCH(S2,S3) P.C.B. (REP2182A-N)

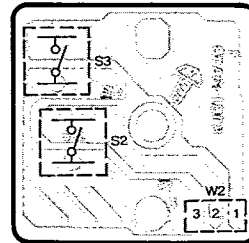

E LOADING MOTOR P.C.B. (REP2182A-N)

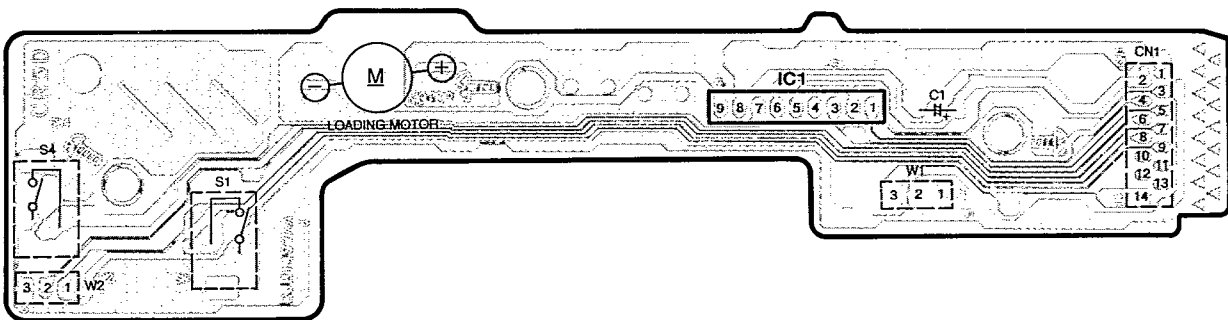

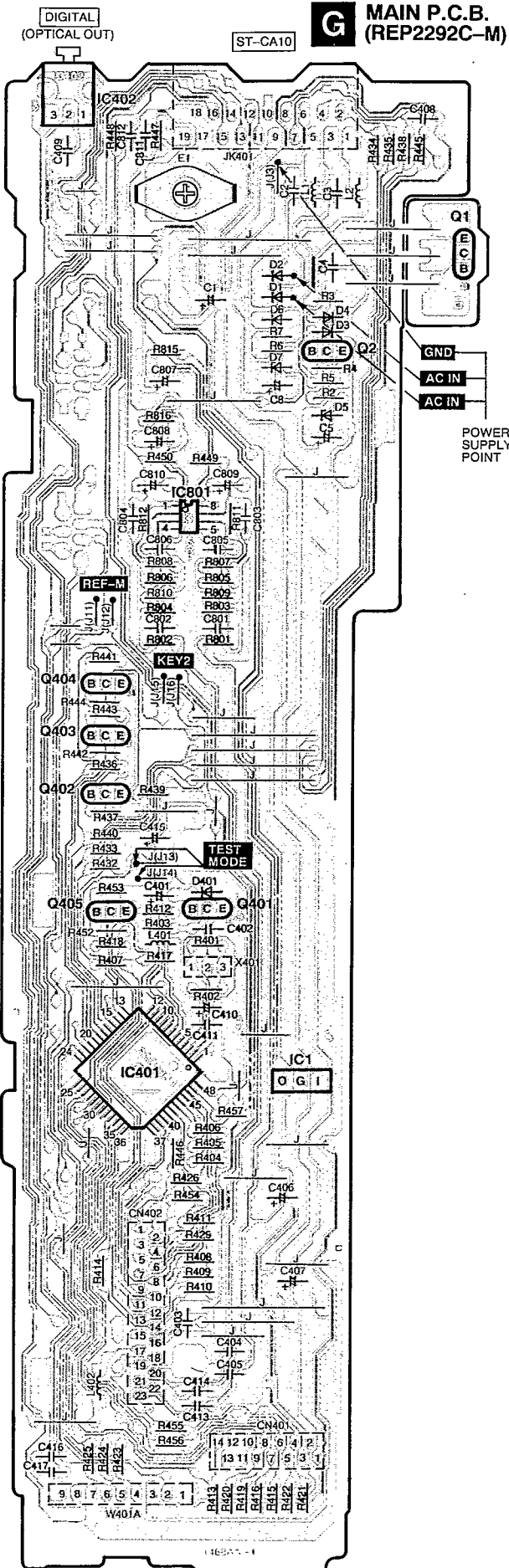

D LED P.C.B. (REP2292C-M)

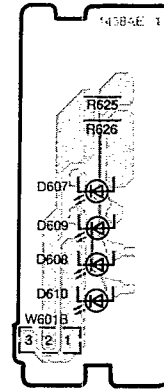

F OPERATION P.C.B. (REP2292C-M)

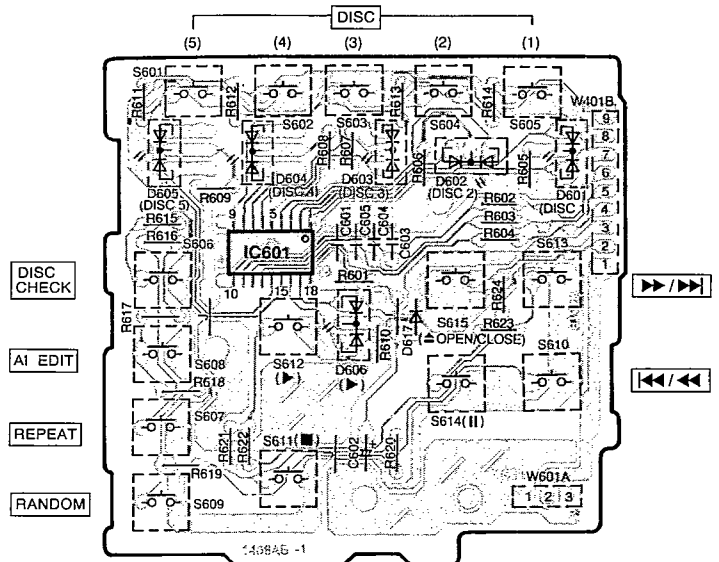

● Terminal guide of IC's , transistors and diodes

■ WIRING CONNECTION DIAGRAM

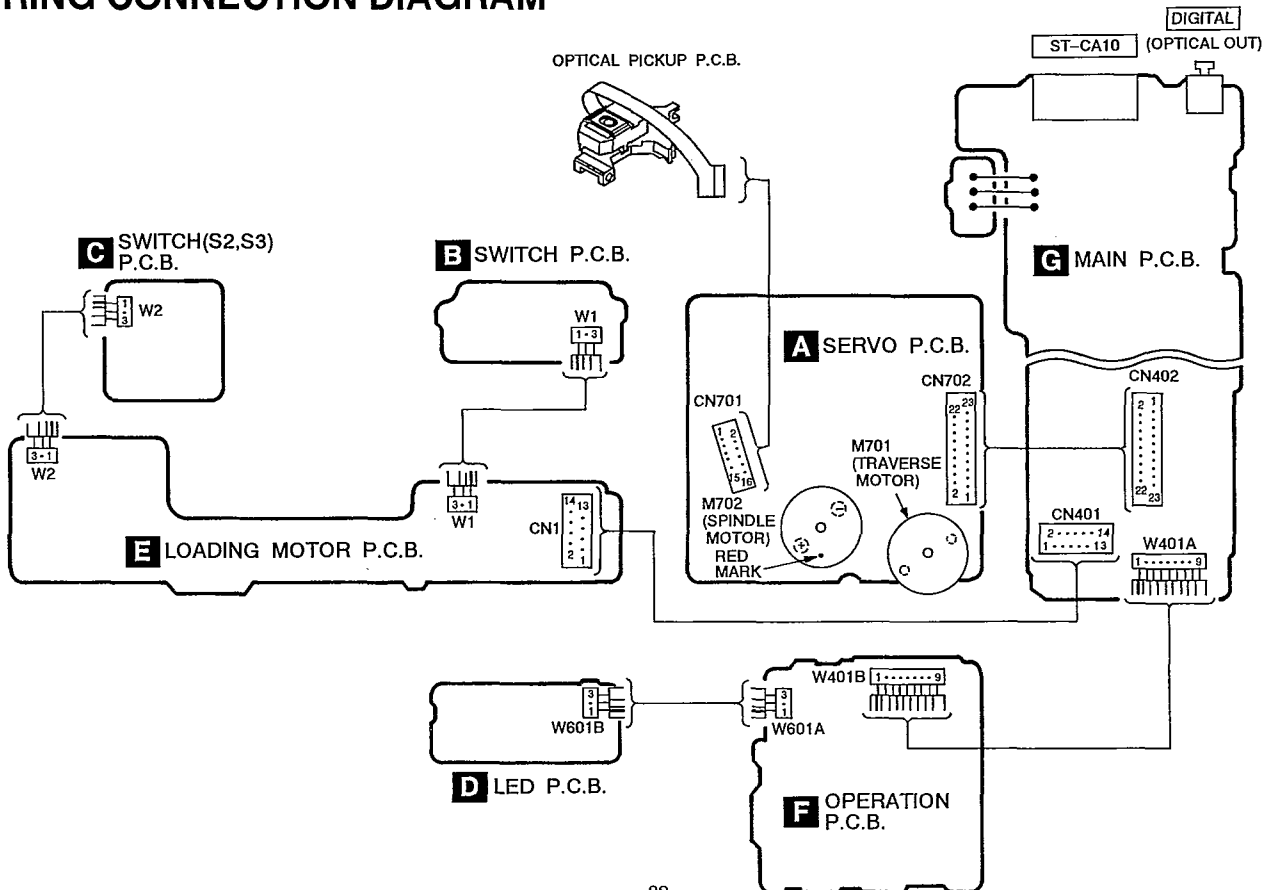

■ TERMINAL GUIDE

● IC401 (LC66538A4G99): System Control

Pin No.	Mark	I/O Division	Function
1	NC	—	Not used, connected to GND
2	VSS	—	GND terminal
3	OSC1	I	Crystal OSC terminal (f=4.23 MHz)
4	OSC2	O	
5	VDD	I	Power supply terminal
6	/RST	I	Reset signal input terminal ("L"=RESET)
7	NO SW	I	Disc tray No. det. input terminal
8	MODE	I	Test mode signal input terminal
9	TEST	—	Test terminal
10	HOLD	I	Not used, connected to power supply
11	MLD	O	Command load signal
12	MDATA	O	Command data signal
13	MCLK	O	Command clock signal
14	VDATA IN	—	Not used, connected to GND
15	EMPHA	—	Not used, open
16	MUTE	—	Not used, open
17	CS	O	Communication request signal to ST-CA10
18	REQ	I	Communication request signal from ST-CA10
19	DTI	I	Communication data signal from ST-CA10
20	DTO	O	Communication data signal to ST-CA10
21	CLK	O	Communication clock signal to ST-CA10
22	VCS	—	Not used, open
23	LSTB	O	LED drive output terminal
24	LCLK	O	LED drive command clock output terminal

Pin No.	Mark	I/O Division	Function
25	LDATA	O	LED drive command clock output terminal
26	—	—	Not used, connected to power supply
27	STOCK SW	I	Stocker position det. input terminal
28	UP SW	I	Disc tray up position det. input terminal
29	VCLK	—	Not used, open
30	VDATA	—	Not used, open
31	KEY1	I	Key switch det. input terminal
32	KEY2		
33	PLY SW	I	Disc tray play position det. input terminal
34	OPEN SW	I	Disc tray open position det. input terminal
35	REV	O	Loading motor reverse signal output terminal
36	FWD	O	Loading motor forward signal output terminal
37	SENSE	I	Sense signal input terminal
38	FLOCK	I	Optical servo condition (focus) ("L": lead-in)
39	TLOCK	I	Optical servo condition (tracking) ("L": lead-in)
40	REST SW	I	Rest position det. input terminal
41	SVRST	O	Reset signal to servo processor
42	STAT	I	Status signal input terminal
43	SUBQ	I	Sub-code Q data input terminal
44	DMUTE	—	Not used, open
45	SQCK	O	Sub-code Q resister clock output terminal
46	BLKCK	I	Sub-code block clock input terminal (f=75Hz)
47	ESPD	—	Not used, connected to power supply
48	GMUTE	—	Not used, open

● IC702 (MN662740RM1): Servo processor/ digital signal processor/ digital filter/ D/A converter

Pin No.	Mark	I/O Division	Function
1	BCLK	O	Serial bit clock terminal (Not used, open)
2	LRCK	O	L/R discriminating signal (Not used, open)
3	SRDATA	O	Serial data (Not used, open)
4	DVDD1	I	Power supply (digital circuit) terminal
5	DVss 1	—	GND (digital circuit) terminal
6	TX	O	Digital audio interface signal
7	MCLK	I	Command clock signal
8	MDATA	I	Command data signal
9	MLD	I	Command load signal ("L":LOAD)
10	SENSE	O	Sense signal (OFT, FESL, NACEND, NAJEND, POSAD, SFG)
11	/FLOCK	O	Optical servo condition (focus) ("L": lead-in)
12	/TLOCK	O	Optical servo condition (tracking) ("L": lead-in)
13	BLKCK	O	Sub-code block clock (f=75Hz) (Not used, open)
14	SQCK	I	Sub-code Q register clock
15	SUBQ	O	Sub-code Q data
16	DMUTE	I	Muting input ("H": MUTE) (Not used, connected to GND)
17	STAT	O	Status signal (CRC, CUE, CLVS, TTSTOP, FCLV, SQCK)
18	/RST	I	Reset signal ("L": reset)
19	SMCK	O	System clock (f=4.2336MHz) (Not used, open)
20	PMCK	O	Frequency division clock signal (No used, open) $(f = \frac{1}{1.92} \times ck = 88.2\text{kHz})$
21	TRV	O	Traverse servo control

Pin No.	Mark	I/O Division	Function
22	TVD	O	Traverse drive signal
23	PC	O	Turntable motor drive signal ("L": ON)
24	ECM	O	Turntable motor drive signal (Forced mode)
25	ECS	O	Turntable motor drive signal (Servo error signal)
26	KICK	O	Kick pulse output
27	TRD	O	Tracking drive signal output
28	FOD	O	Focus drive signal output
29	VREF	I	D/A driven output (TVD, ECS, TRD, FOD, FBAL, TBAL) normal voltage input terminal
30	FBAL	O	Focus balance adj. output
31	TBAL	O	Tracking balance adj. output
32	FE	I	Focus error signal (analog input)
33	TE	I	Tracking error signal (analog input)
34	RFENV	I	RF envelope signal
35	VDET	I	Oscillation det. signal ("H": det.)
36	OFT	I	Off track signal ("H": Off track)
37	TRCRS	I	Track cross signal input
38	/RFDET	I	RF detection signal ("L": detection)
39	BDO	I	Dropout detection signal ("H": dropout)
40	LDON	O	Laser power control ("H": ON)
41	TES	O	Tracking error shunt output ("H": dropout)
42	PLAY	O	Play signal ("H": play) (Not used, open)

Pin No.	Mark	I/O Division	Function
43	WVEL	O	Double velocity status signal ("H": double) (Not used, open)
44	ARF	I	RF signal input
45	IREF	I	Reference current input
46	DRF	I	DSL bias terminal (Not used, open)
47	DSL F	I/O	DSL loop filter terminal
48	PLL F	I/O	PLL loop filter terminal
49	VCO F	I/O	VCO loop filter terminal
50	AV _{DD2}	I	Power supply (analog circuit) terminal(2)
51	AV _{SS2}	—	GND (analog circuit) terminal
52	EFM	O	EFM signal (Not used, open)
53	PCK	O	PLL extract clock (f= 4.3218MHz) (Not used, open)
54	PDO	O	Phase comparated signal of EFM and PCK (Not used, open)
55	SUBC	O	Sub-code serial output clock (Not used, open)
56	SBCK	I	Sub-code serial data (Not used, connected to power supply)
57	V _{SS}	—	GND terminal
58	X1	I	Crystal oscillator terminal (f=16.9344MHz)
59	X2	O	
60	VDD	I	Reset signal ("L": reset)
61	BYTCK	O	Byte clock signal (Not used, open)
62	/CLDCK	O	Sub-code frame clock signal (f CLDCK=7.35KHz: Normal) (Not used, open)
63	FCLK	O	Crystal frame clock (Not used, open)
64	IPFLAG	O	Interpolation flag terminal (Not used, open)

Pin No.	Mark	I/O Division	Function
65	FLAG	O	Flag terminal (Not used, open)
66	CLVS	O	Turntable servo phase synchro signal ("H": CLV, "L": Rough servo) (Not used, open)
67	CRC	O	Sub-code CRC check terminal ("H": ON, "L": NG) (Not used, open)
68	DEMPH	O	De-emphasis ON signal ("H": ON) (Not used, open)
69	RESY	O	Re-synchronizing signal of frame sync. (Not used, open)
70	/RST2	I	Reset terminal after "MASH" circuit (Not used, connected to power supply)
71	/TEST	I	Test terminal (Normal: "H") (Not used, connected to power supply)
72	AV _{DD1}	I	Power supply (analog circuit) terminal (1)
73	OUTL	O	Lch audio signal
74	AV _{SS1}	—	GND (analog circuit) terminal (1)
75	OUTR	O	Rch audio signal
76	RSEL	I	Polarity direction control terminal of RF signal (Not used, connected to power supply)
77	CSEL	I	Frequency control terminal of crystal oscillator (Not used, connected to GND)
78	PSEL	I	Test terminal (Normal:"L") (Not used, connected to GND)
79	MSEL	I	"SMCK" terminal frequency select ("L": SMCK=4.2336MHz) (Not used, connected to GND)
80	SSEL	O	"SUBQ" terminal mode select ("H": Q code buffer) (Not used, connected to power supply)

● IC701 (AN8835SBE1): Servo amp

Pin No.	Mark	I/O Division	Function
1	PDA	I	Focus signal input terminal 1 (Ach)
2	PDB	I	Focus signal input terminal 2 (Bch)
3	VCC	I	Power supply terminal
4	LPD	I	Laser PD signal
5	LD	O	Laser power auto control output
6	RF	O	RF amp terminal
7	RF IN	I	AGC input terminal
8	CAGC	I	AGC detection capacitor input
9	ARF	O	RF signal
10	CSBRT	I	OFTR capacitor connection terminal
11	CEA	I	HPF-AMP capacitor connection terminal
12	BDO	O	Dropout detection control
13	LDON	I	LD APC ON/OFF ("H": ON, "L": OFF)
14	GND	—	GND terminal

Pin No.	Mark	I/O Division	Function
15	/RFDET	O	RF det. signal ("L": det.)
16	CROSS	O	Tracking error zero cross output
17	OFTR	O	Off track detection ("H": det.)
18	VDET	O	Oscillation det. signal ("H": det.)
19	ENV	O	Envelope output terminal
20	TEBPF	I	Oscillation detect input terminal (Not used, open)
21	CCRS	I	CROSS capacitor connection terminal
22	TE	O	Tracking error signal
23	FE	O	Focusing error signal
24	TBAL	I	Tracking balance adj. input
25	FBAL	I	Focus balance adj. input
26	VREF	O	Reference voltage output
27	PDE	I	Tracking signal input terminal 1 (Ech)
28	PDF	I	Tracking signal input terminal 2 (F ch)

● IC703(AN8389SE1): Focus coil/ tracking coil/ traverse coil/ spindle motor

Pin No.	Mark	I/O Division	Function
1	Vcc	I	Power supply terminal
2	VREF	I	Reference voltage input
3	IN4	I	Motor driver (4) input
4	IN3	I	Motor driver (3) input
5	GND	—	GND terminal
6	NC	—	Not used, connected to GND
7	NRESET	O	Reset terminal (Not used, open)
8	GND	—	GND terminal
9	IN2	I	Motor driver (2) input
10	PC2	I	PC2 (power cut) input
11	IN1	I	Motor driver (1) input
12	PC1	I	PC1 (power cut) input (Not used, connected to GND)

Pin No.	Mark	I/O Division	Function
13	PVcc1	I	Driver power supply (1)
14	PGND1	—	Driver GND terminal (1)
15	D1-	O	Motor driver (1) output terminal (-)
16	D1+	O	Motor driver (1) output terminal (+)
17	D2-	O	Motor driver (2) output terminal (-)
18	D2+	O	Motor driver (2) output terminal (+)
19	D3-	O	Motor driver (3) output terminal (-)
20	D3+	O	Motor driver (3) output terminal (+)
21	D4-	O	Motor driver (4) output terminal (-)
22	D4+	O	Motor driver (4) output terminal (+)
23	PGND2	—	Driver GND terminal (2)
24	PVcc2	I	Driver power supply (2)

RESISTORS AND CAPACITORS

Notes: * Capacity values are in microfarads (μF) unless specified otherwise, P=Pico-farads (pF) F=Farads (F)
* Resistance values are in ohms, unless specified otherwise, 1K=1,000 (OHM), 1M=1,000k (OHM)

Ref. No.	Part No.	Values & Remarks	Ref. No.	Part No.	Values & Remarks	Ref. No.	Part No.	Values & Remarks
		RESISTORS	R616	ERDS2TJ682T	1/4W 6.8K	C1	ECA1AKF820E	10V 82U
R2	ERDS2TJ471	1/4W 470	R617	ERDS2TJ472	1/4W 4.7K			< SERVO P. C. B >
R3	ERDS2TJ223	1/4W 22K	R618	ERDS2TJ332	1/4W 3.3K			RESISTORS
R4	ERDS2TJ101	1/4W 100	R619	ERDS2TJ222	1/4W 2.2K			
R5	ERDS2TJ102	1/4W 1K	R620	ERDS2TJ182	1/4W 1.8K	R701	ERJ6GEYJ4R7V	1/10W 4.7
R6, 7	ERDS2TJ271	1/4W 270	R621	ERDS2TJ152	1/4W 1.5K	R703	ERJ6GEYJ823	1/10W 82K
R401	ERDS2TJ105T	1/4W 1M	R622	ERDS2TJ122	1/4W 1.2K	R704	ERJ6GEYJ102A	1/10W 1K
R402	ERDS2TJ102	1/4W 1K	R623	ERDS2TJ102	1/4W 1K	R705	ERJ6GEYJ103V	1/10W 10K
R403	ERDS2TJ104	1/4W 100K	R624	ERDS2TJ821	1/4W 820	R706	ERJ6GEYJ102A	1/10W 1K
R404	ERDS2TJ471	1/4W 470	R625, 626	ERDS2TJ221	1/4W 220	R707	ERJ6GEYJ474V	1/10W 470K
R405	ERDS2TJ101	1/4W 100	R801, 802	ERDS2TJ102	1/4W 1K	R708	ERJ6GEYJ154V	1/10W 150K
R406	ERDS2TJ471	1/4W 470	R803, 804	ERDS2TJ104	1/4W 100K	R709	ERJ6GEYJ683V	1/10W 68K
R407	ERDS2TJ123	1/4W 12K	R805-808	ERDS2TJ223	1/4W 22K	R711	ERJ6GEYJ154V	1/10W 150K
R408-413	ERDS2TJ103	1/4W 10K	R809, 810	ERDS2TJ273	1/4W 27K	R712	ERJ6GEYJ221V	1/10W 220
R414	ERDS2TJ471	1/4W 470	R811, 812	ERDS2TJ332	1/4W 3.3K	R714	ERJ6GEYJ121V	1/10W 120
R415-422	ERDS2TJ103	1/4W 10K	R815, 816	ERDS2TJ101	1/4W 100	R717, 718	ERJ6GEYJ102A	1/10W 1K
R423-425	ERDS2TJ101	1/4W 100			CAPACITORS	R720	ERJ6GEYOR00A	1/10W 0.00
R426	ERDS2TJ102	1/4W 1K	C1 Δ	ECA1CM222B	16V 2200U	R721	ERJ6GEYJ101V	1/10W 100
R429	ERDS2TJ103	1/4W 10K	C2, 3	ECBT1E103ZF	25V 0.01U	R722	ERJ6GEYJ563V	1/10W 56K
R432	ERDS2TJ123	1/4W 12K	C4	ECBT1H102KB5	50V 1000P	R723	ERJ6GEYJ182V	1/10W 1.8K
R433	ERDS2TJ103	1/4W 10K	C5	RCE1CKA470BG	16V 47U	R724	ERJ6GEYJ333V	1/10W 33K
R434	ERDS2TJ102	1/4W 1K	C8	ECA1EM101B	25V 100U	R725	ERJ6GEYJ472V	1/10W 4.7K
R435	ERDS2TJ101	1/4W 100	C401	RCE1HKA3R3BG	50V 3.3U	R726	ERJ6GEYJ473V	1/10W 47K
R436, 437	ERDS2TJ472	1/4W 4.7K	C402, 403	ECBT1H102KB5	50V 1000P	R727	ERJ6GEYJ822V	1/10W 8.2K
R438	ERDS2TJ102	1/4W 1K	C404, 405	ECBT1E103ZF	25V 0.01U	R728	ERJ6GEYJ103V	1/10W 10K
R439	ERDS2TJ123	1/4W 12K	C406	RCE0JKA221BV	6.3V 220U	R731	ERJ6GEYJ822V	1/10W 8.2K
R440	ERDS2TJ473	1/4W 47K	C407	ECEA1AKA221B	10V 220U	R735, 736	ERJ6GEYJ101V	1/10W 100
R441	ERDS2TJ472	1/4W 4.7K	C408	ECBT1H101KB5	50V 100P	R744	ERJ6GEYJ103V	1/10W 10K
R442	ERDS2TJ332	1/4W 3.3K	C409	ECBT1E103ZF	25V 0.01U	R745	ERJ6GEYJ155V	1/10W 1.5M
R443, 444	ERDS2TJ472	1/4W 4.7K	C410	RCE0JKA470BG	6.3V 47U	R748	ERJ6GEYJ182V	1/10W 1.8K
R445	ERDS2TJ102	1/4W 1K	C411	ECBT1H104ZF5	50V 0.1U	R749	ERJ6GEYJ682V	1/10W 6.8K
R446	ERDS2TJ472	1/4W 4.7K	C413, 414	ECBT1H101KB5	50V 100P	R750, 751	ERJ6GEYJ473V	1/10W 47K
R447, 448	ERDS2TJ221	1/4W 220	C415	RCE0JKA470BG	6.3V 47U	R752	ERJ8GEYJ220V	1/8W 22
R449, 450	ERDS2TJ473	1/4W 47K	C416, 417	ECBT1H102KB5	50V 1000P	R770, 771	ERJ6GEYJ155V	1/10W 1.5M
R452	ERDS2TJ103	1/4W 10K	C601	ECBT1E103ZF	25V 0.01U	R772	ERJ6GEYJ273V	1/10W 27K
R453	ERDS2TJ473	1/4W 47K	C602	ECEA1HKA010B	50V 1U			CHIP JUMPERS
R454	ERDS2TJ102	1/4W 1K	C603-605	ECBT1H101KB5	50V 100P	RJ701-709	ERJ8GEYOR00A	CHIP JUMPER
R455, 456	ERDS2TJ471	1/4W 470	C801, 802	ECBT1H102KB5	50V 1000P	RJ714-717	ERJ8GEYOR00A	CHIP JUMPER
R457	ERDS2TJ473	1/4W 47K	C803, 804	ECBT1H331KB5	50V 330P	RJ721-731	ERJ6GEYOR00A	CHIP JUMPER
R601	ERDS2TJ104	1/4W 100K	C805, 806	ECBT1H121KB5	50V 120P			CAPACITORS
R602-604	ERDS2TJ101	1/4W 100	C807, 808	RCE0JKA470BG	6.3V 47U			
R605-610	ERDS2TJ271	1/4W 270	C809, 810	ECEA1AKA220B	10V 22U			
R611	ERDS2TJ223	1/4W 22K	C811, 812	ECBT1H102KB5	50V 1000P			
R612	ERDS2TJ123	1/4W 12K			< LOADING P. C. B. >	C701	ECEA0JKA330I	6.3V 33U
R613	ERDS2TJ682T	1/4W 6.8K			CAPACITORS	C702	ECU2NE104MBN	25V 0.1U
R614	ERDS2TJ472	1/4W 4.7K				C703	ECEA0JKA101I	6.3V 100U
R615	ERDS2TJ123	1/4W 12K				C704, 705	ECU2NE104MBN	25V 0.1U

Ref. No.	Part No.	Values & Remarks	Ref. No.	Part No.	Values & Remarks	Ref. No.	Part No.	Values & Remarks
C706	ECUV1H272KBN	50V 2700P	C722	ECUV1H150JCN	50V 15P	C743	ECUWNE104ZFN	25V 0.1U
C707	ECUV1E273KBN	25V 0.027U	C723	ECEA1AKA221I	10V 220U	C744	ECUE1E822KBN	25V 8200P
C708	ECUE1H472KBN	50V 4700P	C724	ECUV1C104MBM	16V 0.1U	C745	ECUE1H102KBN	50V 1000P
C709	ECUE1C473KBN	16V 0.047U	C725, 726	ECUE1H102KBN	50V 1000P	C747	ECUE1H222KBN	50V 2200P
C710	ECUV1H182KBN	50V 1800P	C727, 728	ECEA1HPK010I	50V 1U	C748	ECUV1H471KBM	50V 470P
C711, 712	ECUWNE104ZFN	25V 0.1U	C730	ECUWNE104ZFN	25V 0.1U	C749	ECUZNE104MBN	25V 0.1U
C713	ECUV1C104MBM	16V 0.1U	C731, 732	ECEA0JKA221I	6.3V 220U	C750	ECUV1C104MBM	16V 0.1U
C714	ECEA0JKA101I	6.3V 100U	C733	ECUZNE104MBN	25V 0.1U	C751	ECUZNE104MBN	25V 0.1U
C716	ECUE1H561KBN	50V 560P	C734	ECEA1AKA221I	10V 220U	C752	ECUE1H152KBN	50V 1500P
C717	ECUWNE104ZFN	25V 0.1U	C735-737	ECUWNE104ZFN	25V 0.1U	C753	ECUV1H471KBM	50V 470P
C718	ECUVNC224KBN	16V 0.22U	C738	ECUV1C154KBN	16V 0.15U	C754	ECUE1H471KBN	50V 470P
C721	ECUV1H100DCN	50V 10P	C742	ECUV1E273KBN	25V 0.027U			

REPLACEMENT PARTS LIST

Ref. No.	Part No.	Part Name & Description	Remarks	Ref. No.	Part No.	Part Name & Description	Remarks
		CABINET AND CHASSIS		10	RKA0068-N	FOOT RING	
				11	RFKJLCA7-N	FRAME ASS'Y	
				11-1	SHG1654	FOOT RUBBER	
1	RHD30007-K1	SCREW		12	RMA0931	REINFORCING PLATE	
2	RKMO222-3K	CABINET		13	RSC0425	SHIELD PLATE	
3	XTBS3+8JFZ1	SCREW		14	RFKGLCA10E-K	FRONT PANEL ASS'Y	
4	RWJ1809125KK	FLAT CABLE (9P) (W401)		15	RFKNLCA10EBK	TRAY DOOR ASS'Y	
5	RWJ1803055KK	FLAT CABLE (3P) (W601)		16	RFKNLCA10ECK	BUTTON BLOCK ASS'Y	
6	REZ0555	FFC (14P)		17	RKQ0197-X	SLIDE PIECE (L)	
7	REZ0765	FFC (23P)		18	RKQ0204-X	SLIDE PIECE (R)	
8	RGR0217B-C	REAR PANEL		19	RMB0472	DOOR SPRING	
9	RHD30065	SCREW		20	XTB3+8JFZ	SCREW	

CABINET PARTS LOCATION

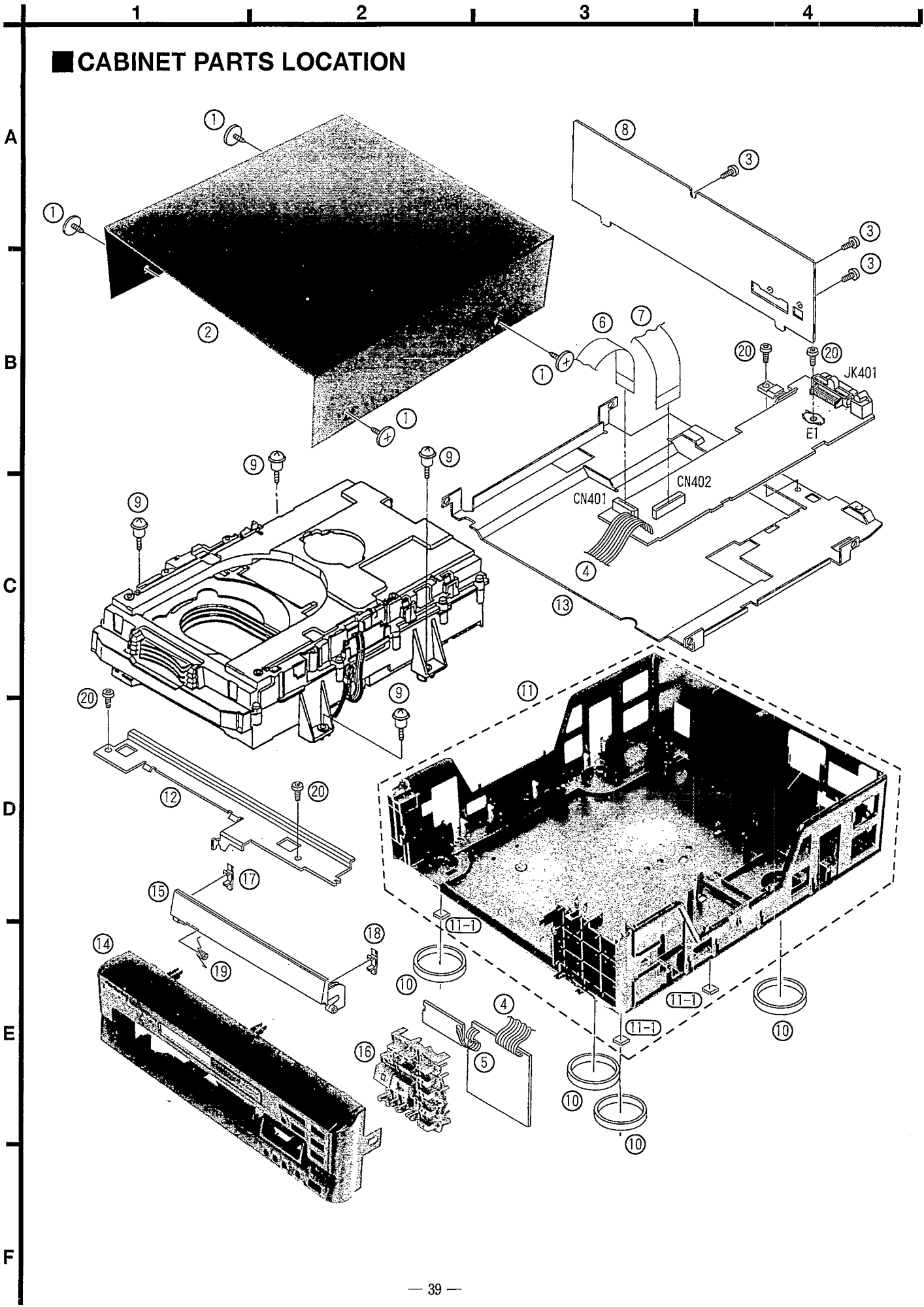

LOADING MECHANISM PARTS

A

B

C

D

E

F

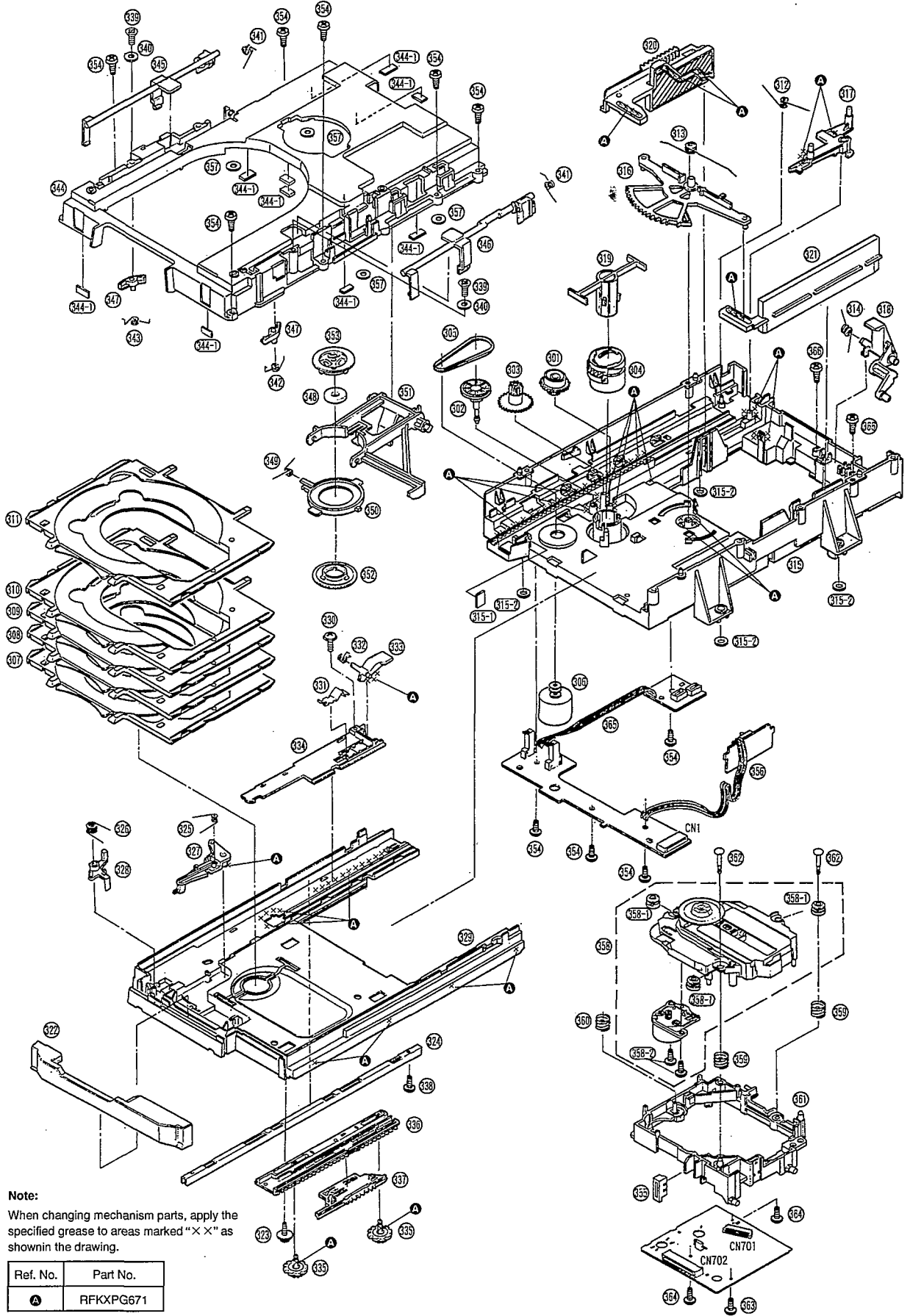

Note:

When changing mechanism parts, apply the specified grease to areas marked "X" as shown in the drawing.

Ref. No.	Part No.
A	RFKXPG671

REPLACEMENT PARTS LIST

Notes: * Important safety notice:

 Components identified by Δ mark have special characteristics important for safety.

Furthermore, special parts which have purposes of fire-retardant (resistors), high-quality sound (capacitors), low-noise (resistors), etc. are used. When replacing any of components, be sure to use only manufacturer's specified parts shown in the parts list.

* Warning: This product uses a laser diode. Refer to caution statements on page 2.

* ACHTUNG: Die Lasereinheit nicht zerlegen.

Die Lasereinheit darf nur gegen eine vom Hersteller spezifizierte Einheit ausgetauscht werden.

Ref. No.	Part No.	Part Name & Description	Remarks	Ref. No.	Part No.	Part Name & Description	Remarks
		LOADING MECHANISM		343	RME0182	LIFT PREVENTION SPRING (2)	
				344	RFKNLCA10EAK	MECHANISM COVER ASS'Y	
				344-1	RMF0221	FELT	
301	RDG0309	INTERMEDIATE GEAR		345	RML0381	HOLD NAIL (1)	
302	RDG0310	PULLEY GEAR		346	RML0382	HOLD NAIL (2)	
303	RDG0311	DRIVE GEAR		347	RML0384	LIFT PREVENTION LEVER	
304	RDG0313	UP/DOWN GEAR		348	RIM245ZA	MAGNET	
305	RDV0036	BELT		349	RME0174	CLAMP LEVER SPRING	
306	RFKPS790PK1	MOTOR ASS'Y		350	RFKNACH430GE	CLAMP BASE ASS'Y	
307	RGQ0170-K	DISC TRAY (1)		351	RML0388-1	CLAMP LEVER	
308	RGQ0171-K	DISC TRAY (2)		352	RMRO761-W	CLAMPER	
309	RGQ0172-K	DISC TRAY (3)		353	RMRO899-K	FIXED PLATE	
310	RGQ0173-K	DISC TRAY (4)		354	XTB3+10J	SCREW	
311	RGQ0174-K	DISC TRAY (5)		355	RMRO975-W	TRAVERSE CAP	
312	RME0170	LOCK LEVER SPRING		356	REZ0793	FLAT CABLE (3P) (W1)	
313	RME0179	ASSIST SPRING		357	RMG0430-Q	RUBBER TUBE	
314	RME0180	TRAY HOLD SPRING		358	RAE0150Z	TRAVERSE DECK ASS'Y	
315	RFKNACH430GC	MECHANISM BASE ASS'Y		358-1	SHGD113-1	FLOATING RUBBER	
315-1	RMF0221	FELT		358-2	SNSD38	SCREW	
315-2	RMG0402-K	RUBBER WASHER		359	RME0109	FLOATING SPRING (1)	
316	RML0379	CONVERSION LEVER		360	RME0142	FLOATING SPRING (2)	
317	RML0380	LOCK LEVER		361	RMK0293	TRAVERSE CHASSIS	
318	RML0383	TRAY HOLD LEVER		362	RMS0123-1	TRAVERSE FIXED PIN	
319	RML0385	UP/DOWN LEVER		363	XTN2+6G	SCREW	
320	RMM0139	SLIDE PLATE (1)		364	XTV2+6G	SCREW	
321	RMM0141	SLIDE PLATE (2)		365	REZ0792	FLAT CABLE (3P) (W2)	
322	RGQ0175-K	TRAY ORNAMENT		366	XTWS3+8T	SCREW	
323	RHD20010	SCREW				INTEGRATED CIRCUIT(S)	
324	RMA0868	REINFORCING ANGLE		IC1	LM2940T5	REGULATOR	Δ
325	RME0171	BASE LOCK LEVER SPRING		IC401	LC66538A4G99	SYSTEM CONTROL	
326	RME0172	CARRIER LOCK LEVER SPRING		IC402	TOTX178	TRANSMISSION MODULE	
327	RML0377	BASE LOCK LEVER		IC601	NJU3713GTE1	LED DRIVE	
328	RML0378	CARRIER LOCK LEVER		IC801	BA4558FHTT1	L. P. F.	
329	RMRO884-K	TRAY BASE				TRANSISTOR (S)	
330	RHD20009-1	SCREW					
331	RMCO274	TRAY HOOK SPRING		Q1	ZSB1548PQAU	TRANSISTOR	Δ
332	RME0173	CARRIER ARM SPRING		Q2	ZSC3311AIQST	TRANSISTOR	Δ
333	RML0376-1	CARRIER ARM		Q401	DTC114YSTP	TRANSISTOR	
334	RMM0137	CARRIER		Q402-404	ZSC3311AIQST	TRANSISTOR	
335	RDG0312	SPEED GEAR		Q405	ZSA1309A-R	TRANSISTOR	
336	RMM0134	DRIVE RACK				DIODE (S)	
337	RMM0135	CUSHION RACK					
338	XTN2+6F	SCREW		D1.2	RL1N4003N02	DIODE	Δ
339	XTS3+8J	SCREW					
340	XWE4E10	WASHER					
341	RME0178	HOLD SPRING					
342	RME0181	LIFT PREVENTION SPRING (1)					

981

Ref. No.	Part No.	Part Name & Description	Remarks	Ref. No.	Part No.	Part Name & Description	Remarks
D3, 4	MA165	DIODE				SWITCH(ES)	
D5	MA4075MTA	DIODE	△				
D6	RL1N4003N02	DIODE		S1	RSH1A005	STOCKER POSITION DET.	
D7	MA4051MTA	DIODE		S2	RSH1A032-U	PLAY POSITION DET.	
D401	MA165	DIODE		S3	RSH1A032-U	UP POSITION DET.	
D601-606	SPR505MDTT	L. E. D.		S4	RSH1A005	TRAY OPEN DET.	
D607-610	LNJ401NPYJA	L. E. D.		S5	RSH1A032-U	DISC NUMBER DET.	
D617	MA165	DIODE				CONNECTOR(S)	
		COIL(S)		CN1	RJS1A6714	CONNECTOR(14P)	
L1, 2	BL02RN2R65T2	COIL	△			<SERVO P. C. B.>	
L401	RLQA100JT-Y	COIL				INTEGRATED CIRCUIT(S)	
L402	BL02RN2R65T2	COIL					
		OSCILLATOR(S)		IC701	AN8835SBE1	SERVO AMP	
				IC702	MN662740RM1	SERVO PROCESSOR	
X401	EF0EC4234T3	OSCILLATOR(4.23MHz)		IC703	AN8389SE1	COIL & MOTOR DRIVE	
		SWITCH(ES)				TRANSISTOR(S)	
S601	EVQ21405R	DISC5		Q701	2SB709S	TRANSISTOR	
S602	EVQ21405R	DISC4				OSCILLATOR(S)	
S603	EVQ21405R	DISC3					
S604	EVQ21405R	DISC2		X701	RSXB16M9J02T	OSCILLATOR(16.9344MHz)	
S605	EVQ21405R	DISC1				SWITCH(ES)	
S606	EVQ21405R	DISC CHECK					
S607	EVQ21405R	REPEAT		S701	RSM0006-P	REST DETECTOR	
S608	EVQ21405R	AI EDIT				CONNECTOR(S) AND SOCKET(S)	
S609	EVQ21405R	RANDOM					
S610	EVQ21405R	R. SKIP/SEARCH		CN701	RJU035T016-1	SOCKET(16P)	
S611	EVQ21405R	STOP		CN702	RJS1A6723-1Q	CONNECTOR(23P)	
S612	EVQ21405R	PLAY				<GREASE OR JIG/TOOL>	
S613	EVQ21405R	F. SKIP/SEARCH				TEST DISC	
S614	EVQ21405R	PAUSE		SA1	SZZP1054C	PLAYABILITY TEST DISC	
S615	EVQ21405R	OPEN/CLOSE				GREASE	
		CONNECTOR(S)		SA2	RFKXPG671	MOLYCOAT GREASE PG671	
CN401	RJS1A6814	CONNECTOR(14P)					
CN402	RJS1A6823	CONNECTOR(23P)					
JK401	RJT065K19	CONNECTOR(19P)					
		EARTH PLATE(S)					
E1	SNE1004-2	EARTH PLATE					
		<LOADING P. C. B. >					
		INTEGRATED CIRCUIT(S)					
IC1	BA6418N	MOTOR DRIVE					