

# Explode 1

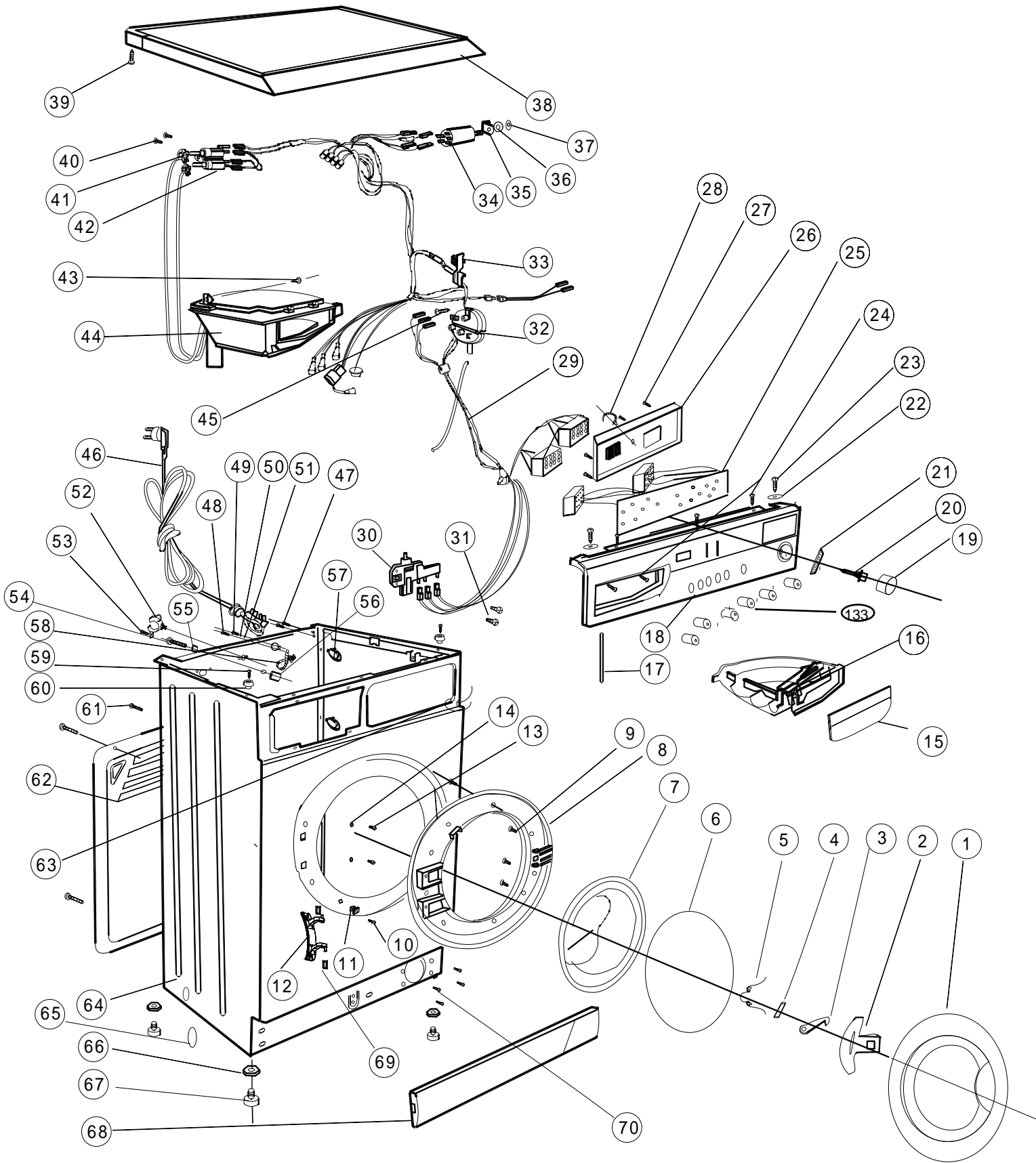

# Explode 2

